







2015

www.studiospares.com

Tel: 020 8208 9930

4-31	 Recorders + Media + Mixers Portable Recorders + CD Recorders + Analogue + Digital Mixers + Portable PA
32-47	 Outboard Equipment Complete Channels + Reverb + Equalisers + Compressors + Power Amps
48-63	 DJ Equipment Turntables + Mixers + CD Players + Headphones + Stands + Lighting + Tools
64-84	 Computer Zone Audio Interfaces + Soundcards + Digital Converters + MIDI + Synths + Software
86-139	 Microphones Condenser + Instrument + Vocal + Boundary + Radiomics + DI Boxes + Phantom PSU
140-177	 Headphones + Speakers Headphones + Headsets + Studio Monitors + PA Speakers + PA Systems
178-201	 Stands Microphone + Speaker + Equipment + Instrument + Keyboard + Workstations
202-215	 Instruments Guitars + Synthesisers + Drums + Percussion + Stringed + Wind Instruments
216-249	 Cables + Connectors Cable + Multicore + Analogue + Digital + Optical Connectors + Mains Components
250-274	 Leads + Looms + Snakes Leads + Patch Cords + Looms + Snakes + Cable Drum Snakes
276-297	 Cases + Racks + Service Flight + Equipment Cases + Rack Hardware + Patch Panels + Tools
298-317	 Acoustics Acoustic Tiles + Sound Treatment + Isolation Rooms + Bass Traps

WELCOME



964 North Circular Road, Staples Corner,
Neasden, London, NW2 7JR.

www.studiospares.com

Methods of Ordering

Website	www.studiospares.com
Tel (UK Calls)	020 8208 9930
Tel (Non-UK Calls)	+44 (0)20 8208 9930
Free Fax (Orders Only)	0800 731 3767
Returns	020 8208 9951
Accounts	020 8208 9936/34
Email	sales@studiospares.com
Post	Send orders to address above

Next Day Delivery cut off time 3pm

Delivery Charges

Mainland GB

(Excludes Highlands and Islands)

Express per 20kg	Next working day	£7.00
Standard per 20kg	2 - 5 working days	£5.00
Letter post (<1kg + <£25)		£3.00

EU Delivery (<2kg + <£100) £6.00

See page 318 for full delivery charges

Events Schedule

Look out for Studiospares at the following events this year:

Bett Show

January 21 - 24, ExCeL, London

PLASA Focus

May 12 - 13, Royal Armouries, Leeds

CRE International

May 19 - 22, ExCeL, London

PLASA Show

October 4 - 6, ExCeL, London



PLASA members operate to a Code of Ethics guaranteeing integrity.



The MIA is the UK Trade Association of the musical instrument industry.



Winner of Best After Sales Support for the Audio Pro Industry Excellence Awards 2011!

Artwork origination by Studiospares Ltd. Printed by Polestar Ltd.

All prices exclusive of VAT and are correct at time of going to press. Studiospares endeavours to hold the catalogue price for the life of that catalogue. However although many prices have fallen, others are rising significantly. For this reason, we cannot guarantee catalogue prices. Prices and specifications subject to change without notice. All special offers are subject to stock availability. Full terms and conditions on p318. E&OE.

Welcome to over 300 pages of pro audio gear and goodies for 2015!

Great British Service

As you know, we face massive competition, from US giants like Amazon, large German outfits such as Thomann and DV, as well as local suppliers here in the UK. If there's one thing that sets us apart from the rest, it's our commitment to the highest quality service. Studiospares is a true family business, and every member of staff knows I'm passionate about our customers.

The Difference

Firstly our sales team are all expert in different aspects of live sound and studio recording, and because they're not on commission you always get fantastic advice geared to finding the best solution for you. The catalogue offers a unique mix of the latest popular gear, together with the best range of accessories and problem solvers anywhere. And our NW2 location close to the M1 gives you instant access to our huge stock and professional demo facilities.



The 2015 Catalogue

As usual this latest edition is packed with the latest releases from big names like Focusrite, Tascam, Behringer, Roland, Auralex, and Yamaha. But we're even happier to bring you useful microphone accessories, original cases and rack gear, hundreds of acoustic tiles and other solutions, plus of course massive stocks of cable, connectors, leads, looms, stands, and everything else you need to make your show or session run smoothly.

New Logo and Website

Yes, as you will have already noticed, we've updated the Studiospares logo, and have a new website that works as easily on mobiles and tablets as it does on your PC. Check the website for stock quantities, latest prices, more extensive product information, order tracking, and many more products than we can squeeze into this catalogue - plus about 100 new ones every month!



Thank You

For choosing Studiospares for your professional audio supplies for more than 30 years. Thanks to those who have been in touch to show their appreciation, and to those who have suggested improvements. We love getting your feedback and always respond to emails and letters. We look forward to being of service again very soon, whether in store, on the phones, or online.



Barry Lambden
Managing Director

INDEX

Recorders + Players + Mixers

Portable Recorders	4
Portastudios	9
PC Card Recorders	9
CD Recorders	11
Minidisc Recorders	11
Multitrack Recorders	11
CD Players	12
Media Players	13
USB/SD Players	14
CD-R	14
DVD-R	15
Memory Cards	15
Pen Drives	15
Card Readers	16
Minidisks	16
Tape	16
Hard Drives	16
Cassettes	17
Media Accessories	17
Broadcast Consoles	17
Digital Mixers	17
Analogue Mixers	21
Powered Mixers	27
Zone Mixers	28
PA Packages	28
Portable PA	31

Zoom H2n

Portable Recorder

Representing a new generation of portable recording, the H2n is Zoom's most innovative handheld recorder to date.

The Zoom H2n is the only portable recorder with five mic capsules onboard. This design enables the H2n to offer four unique recording modes: Mid-Side (MS) stereo, 90° X/Y stereo, 2-channel and 4-channel surround sound. The H2n's onboard 90° X/Y stereo condenser mics are arranged with the right and left mics on the same axis. Choose between 2-channel mode, which combines the Mid-Side and X/Y mics, and 4-channel mode, which records two separate stereo files, allowing you even more post-production capability comes with Steinberg's WaveLab LE 7 professional audio editing software.

Description	Code	Price (Ex VAT)
H2n	361-290	£82.50
H2n + 4GB SD Card	361-294	£104.17
H2n + 8GB SD Card	361-298	£106.00
H2n Accessory Pack	361-291	£24.99
H2n + Accessory Pack	361-292	£90.83



ZOOM

Marantz PMD620 MKII

Solid State Recorder

Professional recording features and flexible file formats.

- 2 quality condenser mics and monitor speaker
- Solid state SD/SDHC media
- 16 & 24-bit recording, On-board editing and playback features
- Including USB 2.0 connectivity



Description	Code	Price (Ex VAT)
PMD620 MKII	271-870	£207.50
PMD620 MKII + 8GB SDHC Card	271-871	£208.32

Boss Micro-BR BR-80

Handheld Recorder

The ultimate new portable recording and jam-along tool for guitarists and other musicians.

- Three modes: MTR (multi-track recorder), eBand and Live Rec
- Records directly to SD/SDHC memory card (up to 32 GB)
- Built-in stereo condenser mic
- Huge library of built-in backing and rhythm patterns



Description	Code	Price (Ex VAT)
BR-80	309-690	£140.83

RECORDERS

Portable Recorders

Zoom H4nSP
Portable Recorder Package

Zoom's world acclaimed, best-selling H4n is now made available in a more affordable solution package.

The H4nSP provides the H4n, the owners' manual, a plastic case, two AA batteries as well as licenses for download of Steinberg "Cubase LE" music production software and "WaveLab LE" sound editing software. The H4n offers a significantly improved user interface, integral X/Y stereo condenser microphones, a digitally controlled mic pre-amp and the ability to use both internal and external microphones simultaneously for 4-channel recording. It records high-resolution audio at 24bit/96kHz on SD/SDHC media of up to 32GB and is USB 2.0. It also functions as a USB audio interface. Additionally, newly introduced "APH-4nSP" accessory package (Code 377-985) offers a series of additional items to expand the productivity of H4n. The APH-4nSP provides the AC Adapter for use on extended hours, a Windscreen for wind noise prevention, an Attenuator Cable for connecting the H4n line output to the camera mic input, a Splitter Cable to allow simultaneous headphone monitoring and a USB Cable for connection to Mac/PC.

Description	Code	Price (Ex VAT)
H4n	377-980	£132.50
H4n + Accessory Pack	377-986	£154.17
Accessory Pack	377-985	£24.17



ZOOM

Olympus LS-12

Stereo PCM Recorder

Ultra simple stereo recorder with Smart Recording and 130 dB SPL.

- Best in Class Microphone Technology 130dB sound pressure
- Simple to use with the new Recording Dial with Smart Recording
- 2GB built-in memory plus SD(XC) slot
- 96 kHz / 24 bit Linear PCM
- Linear PCM 4bit/96kHz)/MP3/BWF
- Low cut filter to remove unwanted background noise
- 2 Second Pre Record Mode
- Mic and Line in Sockets



Description	Code	Price (Ex VAT)
LS-12	359-360	£107.50
LS-12 + 8GB Card	359-361	£108.32

Sony PCM-M10

Portable Recorder

The smallest member of Sony's family of portable audio recorders is the ideal choice for making live musical, nature sound and field recordings.

- Built-in Electret condenser mics
- 4GB built-in flash memory
- WAV and MP3 format record/play
- Digital pitch control
- Wired remote control



Description	Code	Price (Ex VAT)
PCM-M10	261-170	£183.33

Fostex DC-R302

Portable Recorder

Professional stereo recorder with on-board 3-ch pre-amp audio microphone/line mixer designed for use with video-capable DSLRs.

- 3 XLR inputs with Limiter + High Pass Filter
- Microphone Out in addition to Line Out for stereo mix to the camera
- Headphone monitoring L, R, Return
- Auto Slate Tone (1kHz / sine wave)
- 2x USB outputs. 48V Phantom power
- Powered by 4 x AA batteries or external DC (9 - 24V)
- Light weight extruded aluminum chassis



Description	Code	Price (Ex VAT)
DC-R302	229-330	£515.83

Zoom H6

6-In 2-Out Handheld Recorder

The revolutionary H6 is the most versatile portable recorder ever...

Four interchangeable input capsules—X/Y, MS, Shotgun, and Dual XLR/TRS Combo—make the H6 the ultimate chameleon of the audio world, and its advanced preamps make it the best-sounding one too. Four mic/line inputs with XLR/TRS combo connectors, gain controls (real knobs!) and -20dB pads for each input. Six-track simultaneous recording. Large full-colour LCD display, angled so it's easy to read in all environments. Records directly to SD, SDHC and SDXC cards up to 128GB. Phantom power for all main inputs: +12/+24/+48V. Up to 24-bit/96kHz audio in BWF-compliant WAV or a variety of MP3 formats. Multitrack to stereo internal mixdown. Whatever your application—live recording, professional film/video work, or broadcast ENG (electronic news gathering), etc.—the H6 can handle it with ease.

The Zoom H6 accessory pack includes a remote control unit, a windshield, a mains PSU adapter and a USB cable,

Description	Code	Price (Ex VAT)
H6	377-850	£265.83
H6 + 8GB SDHC Card	377-851	£267.50
H6 + 16GB SDHC Card	377-854	£270.00
H6 + 32GB SDHC Card	377-855	£274.17
H6 Accessory Pack	377-852	£37.50
H6 + Accessory Pack	377-853	£289.00
H6 XLR Microphone	377-858	£40.83
H6 Shotgun Microphone	377-859	£82.50



zoom

Zoom Q2HD

Audio Video Recorder

The high definition audio and video recorder at your fingertips.

Live stream your gigs, special events and more with the Q2HD direct from your computer to the web. The first handheld camcorder to offer mid-side stereo recording giving natural depth and accurate stereo imaging up to 24-bit/96kHz as well as full HD 1920 x 1080P video resolution. (optional) Get great sound no matter what you're shooting with it's Auto Gain function (Concert/Solo/Meeting), a low-cut filter for unwanted background noise and when filming outside reduce wind noise using a windscreens (sold separately).

Description	Code	Price (Ex VAT)
Q2HD	377-830	£65.83
APQ2HD Accessory Pack	377-840	£24.99



zoom

Zoom Q4

Handy Video Recorder

The Zoom Q4 is all about bringing a new dimension to your music.

The Q4 combines high-definition video with high-resolution audio, providing everything you need to shoot amazing videos with incredible sound. Its built-in X/Y microphone allows you to create stunning stereo recordings that cover a wide area while still capturing sound sources in the centre with clarity and definition. High-resolution 24-bit/96k audio with high-definition 1080p video means never having to compromise on quality. Includes Windscreens for field recording.

Description	Code	Price (Ex VAT)
Q4	377-870	£207.50



zoom

PDF catalogue

Want this catalogue on your phone or laptop?

The Studiospares catalogue is now available in PDF format.

visit www.studiospares.com/page/pdfcatalogue!

MORE PRODUCTS online

RECORDERS

Portable Recorders

CONTINUED

Portable Recorder Comparison Chart

										
Portable Recorder	Zoom H4n	Zoom H2n	Roland R-05	Tascam DR100 MKII	Zoom H5	Zoom H6	Marantz PMD620 MKII	Tascam DR05	Tascam DR07 MKII	Zoom H1
Code	361-031	361-290	369-890	228-640	377-950	377-850	271-870	238-050	238-130	361-130
Integrated Stereo Microphone	Yes	Yes	Yes	Yes	Yes	Yes	Yes	Yes	Yes	Yes
Recording Tracks	4	2 + 4 Channel Surround	2	2	4	6	2	2	2 (+ Overdubbing)	2
Microphone Inputs	2x XLR/Jack Combo	1x Mini Jack	Stereo miniature phone type, plug-in powered mic	2x XLR	2x XLR/TRS combo	1x Mini Jack, 4 XLR/TRS Combo Jacks	1x Mini Jack	1x Mini Jack	1x Mini Jack	1x Mini Jack
48V Phantom power	Yes	No	No	Yes	Yes	Yes	No	No	No	No
Line Inputs	2x XLR/Jack Combo	1x Mini Jack	1x Mini Jack	1x Mini Jack	2x XLR/TRS combo	1x Mini Jack, 4 XLR/TRS Combo	1x Mini Jack	1x Mini Jack	1x Mini Jack	1x Mini Jack
Storage Medium	SD Card, SDHC Card	SD Card, SDHC Card	SD Card, SDHC format compatible	SD Card, SDHC Card	SD Card, SDHC Card	Micro SD, SD, SDHC, SDXC Card	SD Card, SDHC Card	Micro SD	Micro SD	Micro SD
Included Storage	1GB	2GB	2GB	2GB	2GB	2GB	512MB	2GB	2GB	2GB
Maximum Memory In GB	32GB	32GB	32GB	32GB	32GB	2GB SD 32GB SDHC 128GB SDXC	32GB	32GB	32GB	32GB
Headphone Output	Yes	Yes	Yes	Yes	Yes	Yes	Yes	Yes	Yes	Yes
Integrated Speaker	Yes	Yes	No	Yes	Yes	Yes	Yes	Yes	No	Yes
Maximum Resolution In bit	24 bit	24 bit	24 bit	24 bit	24 bit	24 bit	24 bit	24 bit	24 bit	24 bit
Maximum Sample Rate	96kHz	96kHz - Stereo Mode, 48kHz - 4 Channel Mode	96kHz	96kHz	96kHz - Stereo Mode	96kHz	96kHz	96kHz	96kHz	96kHz
Limiters	Yes	Yes	Yes, via switch	Yes	Yes	Yes	No	Yes	Yes	Yes
Recording Format	MP3, WAV, BWF	MP3, WAV	MP3, WAV	MP3, WAV	BWF-compliant WAV, MP3	MP3, WAV	MP3, WAV	MP3, WAV	MP3, WAV	MP3, WAV
Power Feed	PSU, 2 x LR6 (AA) Batteries	(AA) Batteries	AC Adapter Alkaline dry battery LR6 (AA) type x 2 or Nickel Hydrogen battery x 2	Battery, Optional PSU	AA size battery x 2, AC adapter: AD-17 (DC5V/1A/USB-type) (optional), USB bus power	4x 2x AA Battery, Optional AC Adaptor, USB Bus Power	Battery, USB Charging (PC/AC Adapter)	2x AA Battery, NiMH Accumulator, Optional PSU	2x AA Battery, NiMH Accumulator, Optional PSU	1x AA Battery
Dimensions	70 x 156.3 x 35 mm	67.6 x 113.8 x 42.7 mm	103 x 60 x 25 mm	80 x 153 x 35 mm	66.8 x 135.2 x 42.1 mm	77 x 152.8 x 47.8 mm	102 x 62 x 25 mm	61 x 141 x 26 mm	55 x 141 x 26 mm	44 x 136 x 31 mm
Weight	280g	130g (without batteries)	140g	290g	176g	280g	110g	116g (without batteries)	125g	60g
Included in Delivery	Cubase LE4, Windscreen, 1GB SDCard, USB Cable, PSU, Mic Clip Adaptor	2GB SD Card, 2 x AA Batteries, Wavelab LE	Owner's manual, Quick start guide, SD card, Batteries (two AA), USB cable (mini-B type), Windscreen	Windscreen, SD-Card, Carrying Bag, USB Cable, Remote Control	Manual, XYH-5 X/Y mic capsule, SD card (2GB), 2 x AA Batteries, USB cable, Case, Foam windscreen,	XY Microphone, M Microphone, 4x AA Batteries, SD Card, USB Cable, Manual, Cubase LE DVD, Windshield, Case	PSU, SD Card (512 MB), USB Cable, Carrying Strap, Audio Cable, Tripod/Belt Clip Adaptor, CD-ROM user guide	2GB Micro SD Card, 2 x AA Batteries, USB Lead	2GB Micro SD Card, 2 x AA Batteries, USB Lead	2GB Micro SD Card, 1 x AA Battery, USB Lead

Tascam DR100 MKII

Portable Recorder

The MKII update brings added professional features to the DR100.

- 4 upgraded built-in mics, 2 cardioid and 2 omni with revised pre amps
- Limiter and low cut filter
- Mini USB 2.0 jack and cable, built-in speaker, tripod mount, Li-ion battery
- 2GB card and wired/wireless remote control included



Description	Code	Price (Ex VAT)
DR100 MKII	228-640	£207.50
DR100 MKII + 4GB SD Card	228-641	£208.32
DR100 MKII + 8GB SD Card	228-642	£210.83

Tascam DR05

Portable Recorder

Brings high-quality stereo recording to an easy-to-use portable powerhouse with a size and price that anyone can handle.

- Records in MP3 or WAV format to microSD or microSDHC media
- 96kHz/24-bit high-resolution audio
- A pair of microphones handles up to 125dB SPL
- New recording features like Peak Reduction and Quick Menu



Description	Code	Price (Ex VAT)
DR05	238-050	£70.83
DR05 + 4GB SD Card	238-051	£74.70
DR05 + Minijack - Phono Lead	238-052	£73.83
DR05 + Stand Adaptor	238-053	£74.50
DR05 + Lapel Mic	238-054	£85.30

Zoom H1

Portable Recorder

Zoom's smallest recorder ever!

Featuring renowned recording technology and studio-quality microphones, the H1 gives you clean, clear stereo sound effortlessly.

The H1's onboard microphones are configured in an X/Y pattern, and are both arranged on the same axis so that stereo sound is captured with remarkable depth and clarity. It can record linear PCM (WAV) files at 24-bit/96 kHz, which far exceeds CD quality, and also records in MP3 which maximizes recording time.

The H1 supports microSD cards with capacities of up to 32GB for hours of recording, and unwanted background noise can be dramatically reduced using the built-in low cut filter. The H1's stereo microphone input jack accepts stereo line-level inputs. The H1 has a built-in reference speaker and uses USB 2.0. Optional accessory pack (Code 361-200) also available.

Includes extra 2GB microSD card and one AA battery.

Description	Code	Price (Ex VAT)
H1 Black	361-130	£65.83
H1 + APH1 Accessory Pack	361-131	£79.17
H1 + 4GB Micro SDHC Card	361-135	£66.67
H1 + 8GB Micro SDHC Card	361-137	£70.00
H1 + 8GB Micro SDHC Card + APH1 Pack	361-138	£82.50
H1 + Headphones + USB Lead Bundle	361-136	£70.83
H1 White	361-320	£58.32
H1 White + APH1 Accessory Pack	361-321	£69.90
Hot Shoe Mount for H1	377-940	£8.33



zoom

Tascam DR07 MkII

Portable Recorder

Handheld portable recorder with adjustable microphones for AB & XY recording.

TASCAM's DR-07 MKII improves on one of the best-selling portable recorders ever with adjustable microphones, clear sound quality and a great new design. The stereo recorder features a pair of adjustable condenser microphones. The built-in cardioid pattern mics can be moved from an XY position, for tight imaging, to an AB position, for a wider ambient sound. Choose the best sound depending on the source and environment.

The **AK-DR11G** Recorder kit features a fur windscreen, a grip handle for easier handheld use, a power adaptor and a soft carrying case. The **AK-DR11C** Video kit includes Cable with built-in Level Attenuator, Furry Windscreen, Splitter cable for simultaneous connection of headphones and camera, Shoe-mount adaptor and a soft carrying case.

Description	Code	Price (Ex VAT)
DR07 MKII	238-130	£99.00
DR07 MKII + 4GB MicroSD Card	238-131	£119.80
DR07 MKII + MiniJack + Phono Lead	238-132	£117.80
DR07 MKII + Stand Adaptor	238-133	£118.80
DR07 MKII + Lapel Mic	238-134	£132.50
USB PSU for DR07 MKII	635-530	£8.32
AK-DR11G Recorder Kit	238-410	£29.16
AK-DR11C Video Kit	238-420	£32.50



TASCAM

Tascam DR-60D

Linear PCM Recorder/Mixer for DSLR

NEW

The new audio recording solution for on-set filmmakers and videographers using DSLRs.

- Records Up to 4 Channels Simultaneously
- Screw-On DSLR Camera and Mount to Tripod
- Operates on 4 AA Batteries
- Up to 24-bit, 96 kHz PCM Recording
- Two XLR/TRS Combo Mic/Line Jacks
- Switchable 24V and 48V Phantom Power



Description	Code	Price (Ex VAT)
DR-60D	238-470	£174.17

Tascam DR40

Portable Recorder

Giving you the flexibility needed to record anywhere.

- Captures up to four tracks from built-in, high-quality condenser mics
- 96kHz/24-bit high-resolution audio
- Internal mics are adjustable from XY to AB position
- 96kHz/24-bit resolution recording
- Accepts SD or SDHC cards up to 32GB, and a 2GB card is included



Description	Code	Price (Ex VAT)
DR40	238-160	£157.50
DR40 + 4GB SD Card	238-161	£159.50
DR40 + 8GB SD Card	238-162	£160.83
DR40 + Stand Adaptor	238-163	£158.33
DR40 + 3x AA Batteries	238-164	£157.50

SATURDAY DELIVERY no problem

DELIVERY BEFORE 10AM no problem

ALL PRICES EXCLUSIVE OF VAT.

Portable Recorders

RECORDERS

CONTINUED

Roland R-05

WAV/MP3 Recorder

The compact R-05 is easy to use, affordable, and packed with big-ticket features that raise the bar in its price class.

Housed in a strong metal exterior, the R-05 is built to last. The unit makes high-quality stereo recording (24-bit / 96kHz) easy with the built-in stereo mic and external input. It records directly onto SD card and its extended battery life allows for an amazing 16 hours of continuous recording. It features auto record start, auto song split, auto level adjust and a pre record function. It can be used as a high quality portable audio player and to top it all off it comes with a windscreen and tripod mount!

Description	Code	Price (Ex VAT)
R-05	369-890	£137.50
R-05 + 4GB SD Card	369-895	£138.33
R-05 + 8GB SD Card	369-896	£140.00
OP-RP1 Carry Pouch	369-940	£29.17
OP-MSA1 Mic Stand Adaptor	369-910	£15.80
CS-10EM Binaural Mic + Earphones	369-900	£65.83
CS-15S Stereo Microphone	369-950	£83.30
OP-R05C Cover Windshield Set	369-920	£37.50



Includes SD card and two AA batteries.

Roland R-88

8-Channel Recorder Mixer

A new standard in professional portable recording by providing seamless integration of a recorder, mixer and a multi-channel audio interface.

- Simultaneous recording of 8 channels + stereo mix (up to 96kHz)
- 8 XLR inputs, 8 XLR outputs, AES/EBU input/outputs
- Built-in 10in/8out USB audio interface
- SMPTE time code in/out for video sync
- BWF and iXML embedded metadata
- 3 hours of recording time using 32GB SDHC card



Description	Code	Price (Ex VAT)
R-88	369-970	£1299.00

Roland SD-2u

SD Recorder

All-in-one SD recorder for audio recording, music practice and education.

- Easy SD recording and playback
- High-quality stereo microphones and speaker system built in
- Multiple inputs for connecting external devices
- Independent adjustment of playback speed and key
- Built-in tuner and metronome



Description	Code	Price (Ex VAT)
SD-2u	319-000	£324.17

Roland R-44

Portable Recorder

4-channel compact, solid state, portable recorder.

- Captures up to 4 channels of audio
- 16 bit and 24 bit recording depths
- 44.1kHz to 192kHz sample rates
- Built-in limiter
- Studio class effects
- Capture eight channels by linking two units



Description	Code	Price (Ex VAT)
R-44	369-790	£624.00

Roland R-26

Portable Recorder

Discover true multi-dimensional sound with Rolands' innovative hand-held audio field recorder.

- 2 types of built-in stereo mics (omnidirectional & directional)
- 2 XLR/TRS inputs with 48V Phantom power
- Supports 6 channels of simultaneous recording
- High speed USB interface for storage and recording
- Bundled with SONAR LE



Description	Code	Price (Ex VAT)
R-26	309-630	£269.00
OP-R26CW Cover/Windshield	309-640	£65.83

Zoom H5

Handy Recorder

Evolved recording in more ways than one.

The H5 provides four tracks of simultaneous recording and, like the H6, it can use all Zoom interchangeable input capsules. The flexible and powerful H5 provides everything you need to create multitrack recordings, audio for video, and state-of-the-art podcasting, broadcasting and electronic newsgathering. X/Y recording allows you to cover a wide area yet still capture sound sources in the center. The XYH-5 X/Y microphone capsule consists of two matched unidirectional condenser microphones set at a 90 degree angle. An external stereo mic can also be plugged in. The optional MSH-6 Capsule contains dual mic elements. Together with the H5's onboard M5 decoder, they capture a fully mono-compatible stereo image that can actually be adjusted after recording. Dual combo XLR/TRS inputs for both mic- and line-level signals (up to +4dB) with dedicated gain controls.

Powering by 2x AA batteries. Up to 15 hours use on alkalines. Records directly to SD and SDHC cards up to 32GB.

Description	Code	Price (Ex VAT)
H5	377-950	£190.83
H5 + 8GB Card	377-951	£191.66
IQ5 Black iPhone Stereo Microphone	377-880	£65.83
IQ5 White iPhone Stereo Microphone	377-881	£65.83



DELIVERY BEFORE NOON
no problem

1000s
of products
Available from stock!

VISIT
our trade counter
You'll get friendly advice and immediate access to 8000+ product lines!

Portastudios

RECORDERS

Zoom R16

Recorder Interface Control Surface

The R16 combines a remarkable level of functionality with exceptionally intuitive design.

The Zoom R16 is the first digital recorder with a 16-track playback and 8-track simultaneous recording that utilizes Secure Digital (SD) memory. The versatile R16 recorder is 3 production tools in 1. It's a digital multitrack recorder, an audio interface and a control surface, providing you with all the tools necessary to create studio quality recordings anywhere you need to. For recording purposes, the unit supports up to 32GB SD cards, allowing more than 6 hours of recording using all 16 tracks. Additionally, the flexibility of SD recording not only makes the R16 lighter and more portable, it also ensures increased reliability with no concern for a crashing hard drive. It also provides 8 balanced combination XLR-1/4-inch inputs along with one Hi-Z input for direct connection of guitar or bass. With the new Zoom R16, versatility, control and comprehensive features come together in a single device that puts the power to produce professional recordings right at your fingertips.

Includes Steinberg Cubase LE 4 and supports Windows XP/Vista and Mac OS X.



Description	Code	Price (Ex VAT)
R16	361-050	£232.50

Zoom R24

Recorder Interface Control Surface

A complete, compact and powerful portable music creation system that makes creating easier.

The R24's simultaneous 8-track recording capability allows you to capture live band performances, record drum kits with multiple mics and make other recordings of multiple sound sources. It can play back up to 24 tracks of 16/24-bit and 44.1/48 kHz WAV files, and has support for 24-bit/96 kHz encoding which ensures high quality sound. It can be used as a control surface for DAW transport functions and mixing operations. It also features a 24-voice sampler with 8 pads and 3 banks and a pair of built-in high-sensitivity stereo mics. It supports SD and SDHC cards and has a USB 2.0 high speed port for quick transfer of files.



Description	Code	Price (Ex VAT)
R24	361-140	£290.83



Zoom R8

Recorder Sample Interface Controller

The Zoom R8 functions as a digital recorder, USB audio interface, control surface and sampler

- 8-channel playback, 2-channel simultaneous recording
- 48V phantom power for condenser microphones available on 2 tracks
- 150 DSP effects including guitar amp models and mastering effects



Description	Code	Price (Ex VAT)
R8	377-820	£165.83

Tascam DP24/DP32

24/32 Track Portastudio



The DP24/DP32 are multitrack Digital Portastudios with solid-state recording, a colour LCD and channel strip controls to make recording simple. Up to eight tracks can be recorded at a time. Input processing like compression and limiting are available during recording, as well as guitar amp simulation and multi-effects for use with the instrument-level input. Tracks can be viewed and mixed on the large colour LCD and dedicated mixing controls like 19 linear faders and 12 channel strip encoders. Two Mixdown effects including reverb and chorus are also available plus a mastering effect. Songs can be transferred to computer over USB or written to CD with the built-in CD-RW drive.

Description	Code	Price (Ex VAT)
DP24 24 Track	238-170	£449.17
DP32 32 Track	238-310	£507.50

Tascam DP006

Digital Pocketstudio

Music Sketch Pad™ Songwriting Quick-Start Anyone Can Use.

- 2 Mono+2 mono/stereo switchable tracks
- Records max of 2 tracks at a time
- Plays back up to 6 tracks at a time
- Record to SD/SDHC card (Up to 32GB)
- 2 Built-in omni-directional mics
- Two unbalanced 1/4" mic/line input jacks
- Output via 3.5mm mini jack
- Chromatic tuner and metronome included
- High-speed data transfer by USB2.0
- 2GB SD card included
- CD quality recording



Tascam DP008EX

Digital Pocketstudio

Essentially the same as the DP006 but with the following extra features:

- 2x XLR inputs, output via phono plug
- Headphone output slightly higher
- Enhanced Backup Memory
- Output level 6dB higher



Description	Code	Price (Ex VAT)
DP006	238-360	£104.17
DP008EX	238-370	£157.50

RECORDERS

PC Card Recorders

Denon DN-F450R

SD Card Recorder



The DN-F450R offers simplified, cost competitive solid state recording and playback.

- Records and plays back from SD/SDHC card
- Supports WAV and MP3 at 48/44.1 kHz and 32-320 kbps
- Balanced XLR and unbalanced RCA audio input
- 1/4" headphone out with volume control

Denon DN-F650R

SD Card/USB Recorder



A highly versatile solid state recorder designed to fulfil the most demanding playback and recording applications.

- 1U rack mount size
- Records and plays back from SD/SDHC card and USB drives
- Records WAV at 44.1 / 48 / 96kHz and MP3 at 32-320 kbps
- SPDIF and AES/EBU digital input and output
- Optional wired remote (RCF400S) available

Description	Code	Price (Ex VAT)
DN-F450R	271-780	£315.00
DN-F650R	271-790	£499.17
RCF400S Wired Remote	271-770	£265.00

FREE
catalogue

Are you reading someone else's catalogue?
Why not call us and order your own copy...
it's free!

VISIT
our trade counter

You'll get friendly advice and immediate access to 8000+ product lines!

free parking for 40 cars

RECORDERS

PC Card Recorders

CONTINUED

Gemini DPR-1

Digital SD Recorder Rackmounting



The DPR-1 is a 1U Rackmount Digital Recorder from Gemini offering USB flash drive and up to 32GB SDHC compatibility for direct easy recording.

The DPR-1 from Gemini is a standalone digital rack mountable recorder that allows you to record and playback from one convenient device. Its single rackspace design ensures discreet integration into your rack set up, making this handy recording device ideal for DJs, musicians, bars, clubs, schools, houses of worship and anywhere else high-quality audio recording is a must. For true recording versatility, the DPR-1 features a USB port and SD card slot, allowing you to record directly to a thumb drive or memory card.

Description	Code	Price (Ex VAT)
DPR-1	290-010	£132.50



Stageline DPR-110

1U MP3 USB/SD Recorder



Big brother of the Stageline DPR-10. It's a 1U MP3 recorder with USB interface and SD/MMC card slot. USB storage media can directly be connected (e.g. USB hard disk, USB flash drive). For SD/MMC cards up to 8GB (FAT16/FAT32). Table top unit 19". Selectable recording bit rate: 96/128/192kbps. Supports MP3 and WMA and ID3 tags. Track programming & folder navigation.

Description	Code	Price (Ex VAT)
DPR-110	256-620	£149.99

Stageline DPR-10

MP3 USB/CD Compact Recorder



A high quality MP3 recorder that records audio from any line level playback device, e.g CD player, cassette player, laptop, turntable with line level output.

- Compact - only around 7 inches wide - with remote control
- Capture audio, convert it to MP3 & store to SD/MMC/USB stick or HDD
- Store and playback tens of thousands of music tracks, speech, lectures and any other audio files

Description	Code	Price (Ex VAT)
DPR-10	256-610	£119.00

Marantz PMD661 MKII

Professional Portable Field Recorder

Portable field recorder that records directly to SD cards...

The Marantz PMD661 MKII Portable SD Recorder is an updated version of the PMD660. It is robust and versatile, offering an improved top fascia layout with fewer buttons and more highly developed use of multi-functional operation. Also an integrated high quality stereo condenser microphone array for 'point and shoot' operation, and a highly visible 128 x 64 dot matrix OLED (organic LED) display. It records directly to SD or SDHC cards in MP3, WAV or BWF file formats and records up to a bit rate of 24bits. The PMD661 MKII also features 2 XLR inputs which can be switched between mic and line levels and have phantom power. It can record for up to 6 hours on 4 x AA batteries and has a USB 2.0 port.

Description	Code	Price (Ex VAT)
PMD661 MKII + 4GB Card	271-860	£374.17
PMD661 MKII + 8GB Card	271-861	£374.99
RC600 Wired Remote	271-660	£69.00



marantz®

Tascam SSR100/SSR200

CF/SD Recorder



Single-rackspace Solid State Recorders that record to SD, CF or USB memory in WAV or MP3 formats

- Equipped with unbalanced audio I/O
- SPDIF coaxial digital in and out with sample rate converter,
- A wired remote control and a computer keyboard input for folder/file naming and remote control.
- 24-bit WAV file playback
- The SS-R200 features parallel RS-232C serial control balanced & unbalanced I/O

Description	Code	Price (Ex VAT)
SSR100 Unbalanced	238-250	£408.33
SSR200 Balanced	238-260	£399.00

WHY buy tascam?

We only learn the difference between manufacturers when things go wrong. Support for any professional product is essential. Dealing with companies who manufacture domestic equipment and stick rack ears either end is problematic because a professional user has higher expectations than the consumer.

Tascam have served the professional user with appropriate products and service for around five decades and are still going strong.

If you need more information, please contact our technical sales team, who will be glad to help further.

Tascam SSCDR200

CD/CF/SD Rackmount Recorder



The Solid State Recorder designed for the Broadcast and Contractor markets.

- Recording to any available Media (CF, SD/SDHC, USB Memory, and CD-R/CD-RW)
- Record in MP3, audio CD, or convert WAV files to audio CD
- Up to 20 tracks of flash start with RC-20 and RC-5520 remote control devices
- Coaxial S/PDIF & AES/EBU (Auto-detect on Input)

Description	Code	Price (Ex VAT)
SSCDR200	238-240	£732.50

WANT a job?

Are you looking for a stable and rewarding career?

Studiospares are constantly expanding. We require additional staff for a variety of positions, working in a very congenial atmosphere. Practical experience of recording and/or live sound engineering would be preferable.

send in your CV in the first instance

SATURDAY DELIVERY
no problem

DELIVERY BEFORE NOON
no problem

MORE PRODUCTS
online

RECORDERS

CD Recorders

Tascam CD-RW900MKII

CD Recorder



One of the most popular CD recorders on the market!

The CD-RW900MKII features a new tray-loading transport which allows gapless recording when setting track marks. 24 bit A/D & D/A converters, MP3 playback, key control, sample rate conversion, and selectable CD disc reading speed. It provides dedicated analogue front panel input control, rear panel unbalanced (RCA) I/O, and SPDIF digital I/O (optical and coaxial). Recently added features include Auto Cue and Auto Ready from the menu, selectable I/R remote Enable/Disable, and MP3 Action Setting (prevents accidental termination of continuous MP3 playback). Includes Pitch Control on playback (0.1 to 1.0% in 0.1 steps), Auto or Manual track division, Sync Record Start, Power on Play, Elapsed, Remain, Total and Total remain Time display, and CD-Text read and write.

Tascam CD-RW901MKII

CD Recorder/Player

Essentially the same specification as the CD-RW900MK11 but with additional professional level analogue XLR connectors and +4dBu output, a wired remote control, a parallel D-Sub 15 pin port plus a D-Sub 9 pin (RS232C) serial port. Intended for the serious user.

Description	Code	Price (Ex VAT)
CD-RW900MKII	218-970	£332.50
CD-RW900MKII + CD Cakebox	218-975	£332.50
CD-RW901MKII	228-370	£399.17
CD-RW901MKII + CD Cakebox	228-371	£399.99

TASCAM

TEAC CDR-W890

CD Recorder



The TEAC CDR-W890 is a powerful unit capable of transferring to CD from any medium.

- Analogue and optical digital inputs
- Transfer from turntables, tape decks, DAB radio and other hi-fi separates
- Manually adjustable audio levels

Description	Code	Price (Ex VAT)
CDR-W890	223-030	£215.83

1000s
of products
Available from stock!

DELIVERY BEFORE 10AM
no problem

RECORDERS

Minidisc Recorders

Tascam MC-CD1 MKIII

Combined CD Player/Minidisc Recorder



Combines CD playback and MiniDisc recording in a 2U rackmount unit...

- The only combination CD and MiniDisc solution for contractors, broadcast and other installations requiring MD-format compatibility
- Digital I/O, additional file playback from CD and an expanded pitch range for CD playback
- Supports MP3 and WAV file playback
- Can play or record in all major formats: SP, MONO, LP2, and LP4
- Controlled using RS-232C, wireless remote control, or a PS/2 keyboard

Description	Code	Price (Ex VAT)
MD-CD1 MKIII	228-300	£633.33

RECORDERS

Multitrack Recorders

Cymatic LR16

16-Track Recorder

Records direct to stand-alone USB hard & thumb drives.



- 24 bit/44.1 - 96 kHz USB Class Compliant Audio Interface
- iPad/Windows/Mac OS-X (10.5 or higher) compatible
- 16 analogue 1/4" TRS insert-style inputs
- Independent and Global 12dB Input padding
- Zero latency hardware input monitoring



Description	Code	Price (Ex VAT)
LR16	261-030	£329.17

Tascam DR680

Solid State Recorder



The DR-680 brings multi-channel portable recording within reach of any musician for polished live, location and surround recordings.

Up to eight tracks can be recorded to solid-state SD card media (not included) at 96 kHz/24-bit Broadcast WAV quality. Six mic inputs provide phantom power and 60dB of gain for condenser microphones. Record the six microphones along with a digital SPDIF source for 8 track recording. Each mic input has a selectable low-cut filter and analogue limiter for optimal sound. The DR-680 captures stereo audio at 192 kHz/24-bit and also records up to four channels of MP3 audio. Two of the recorders can be connected with a cascade cable for up to 14-track recording on battery power and there's even a built-in speaker to check recordings without headphones. Editing/dubbing can be done in your DAW after transfer of files to your PC.

Description	Code	Price (Ex VAT)
DR680	228-920	£689.17

Tascam DA3000

Multitrack Recorder



The DA-3000 is perfectly designed for stereo PCM/DSD recordings at high sampling frequencies suitable for archival masters. This magnificent unit is capable of recording analogue and digital signals up to 192kHz PCM or 5.6MHz DSD. The unit records to both SDHC cards and UDMA supported CF cards. The variety of inputs and outputs enable connection with all types of studio equipment, including audio interfaces and mic preamps. The analogue inputs and outputs include both XLR and RCA jacks. The digital connections include S/PDIF RCA coaxial and XLR jacks to support AES/EBU. The BNC SDIF-3 inputs and outputs support DSD digital connections. Combining High-Quality Master Recording and High-Quality ADDA Convertering, this is an essential tool for recording engineers.

Description	Code	Price (Ex VAT)
DA3000	238-400	£832.50

PLAYERS

CD Players

Denon DN-C110P

Professional 3U CD Player



The DN-C110P is an entry level CD player designed specifically for use in commercial installations.

The DN-C110P's key attributes include simple operation, reliability and excellent sound quality. Features include CD/CDR playback, MP3 playback and WMA music files from CD/CDR/CDRW media, IR Control, Optical Digital Output, Program Playback, Random Playback, Repeat Playback (track & disc). Simple uncluttered control layout and large central display, for ease of operation and use in ambient lighting conditions. Large 3U rackmountable form, operational simplicity, assured reliability, and legendary Denon sound quality. Optical digital output.

Description	Code	Price (Ex VAT)
DN-C110P	271-420	£165.00

DENON
ELECTRONICS

Denon DN-500C

CD/iPod Player

NEW



Allows greater control over audio than a simple consumer CD player with playback capabilities tailored for professional use.

- CD and WAV, MP3 playback
- Retractable front-mounted iPod Dock
- Pitch control (CD) function with naster key control
- Direct track selection using 0-9 numeric buttons
- Automatic BPM counter and display
- 19-inch rack mountable with 2U removable rack kit included
- Small, wearable IR remote control included
- Detachable, IEC-weighted AC inlet
- Compatible with Denon Pro's Pitch Key App for iOS

Description	Code	Price (Ex VAT)
DN-500C	271-890	£332.50

TEAC CD-P1260

CD Player



Offers playback of computer generated MP3 files as well as CD and CD-R/RW discs.

- Centre-mounted Drive Mechanism
- LCD Display with Music Calendar
- Repeat, Shuffle, Program play
- Intro Check
- 6.3mm Gold-plated Headphone Jack with Volume
- Remote Control
- Dimensions: 435 x 100 x 285mm, 4.1kg

Description	Code	Price (Ex VAT)
CD-P1260	223-000	£89.90

Newhank MP203USB

Dual CD/MP3/USB Player

NEW



The perfect solution for the playback of WAV and MP3 files from CD, CDR, CDRW and MP3 files from USB media.

- Slot in mechanisms with powerful lasers
- +/- 12% pitch control. +/- 16% Pitch bend buttons
- ALPS pitch bend -search jog wheels. Auto Cue
- Seamless loop. Single and continuous mode
- Programmable track sequence. Repeat -1 track or -all tracks function
- Wide angle large backlight LCD displays
- Smart push style rotary encoder for fast folder and track search
- Support both folders and ID3 tags, max 99 folders / 999 tracks /16Gb
- MP103USB - Single CD version of MP203USB

Description	Code	Price (Ex VAT)
MP203USB	232-000	£345.00
MP103USB	232-010	£265.83

Tascam CD-200

CD/MP3 Player

NEW LOWER PRICE



Updated version of the best-selling CD160!

The CD-200 offers a simple, cost-effective solution to installations or PA rental where the extra features of a more complex CD player might go unused. Yet it provides features such as pitch control with an on/off knob, a headphone output with level control, intro check, anti-shock memory, and a variety of convenient playback modes which can help prevent the user from making a mistake. The CD-200 can also play back MP3 and WAV files from data CDs and display ID3 tags and CD-Text. The included wireless remote control gives access to most features and allows a track to be selected directly via a 10-key pad.

Description	Code	Price (Ex VAT)
CD-200	228-660	£174.17

Tascam CD-200i

CD/MP3 Player with iPod Dock

Similar to the CD-200 but with an iPod Dock for audio/video playback and charging.

Description	Code	Price (Ex VAT)
CD-200i	228-710	£324.17

Tascam CD-200iB

CD/MP3 Player with iPod Dock + XLR Outputs

Similar to the CD-200i but with both balanced XLR and unbalanced RCA outputs for both the CD and iPod playback.

Description	Code	Price (Ex VAT)
CD-200iB	238-060	£365.83

Tascam CD-200SB

SD/USB/CD Player Rackmount

The CD-200 series with all the professional features plus SD/SDHC and USB Memory Device playback support. Supports numerous audio formats including CD:CD-DA,Data-D(wav/mp3/mp2). D/SDHC/USB: wav/mp3/mp2/WMA/AAC

Description	Code	Price (Ex VAT)
CD-200SB	238-330	£279.17

Newhank DUS-1

DVD/CD/MP3/USB/SD Player

NEW



The perfect solution for the playback of multiple formats.

- USB and SD card slot
- Full colour wide-angle 4.3-inch LCD TFT screen
- Video out on HDMI, VGA, S-VIDEO, component /YPbPr and composite
- Stereo audio out on RCA, balanced XLR and S/PDIF
- 5 Direct Access buttons for immediate track selection
- Up and down 9-step Digital Key Control
- Copy function from CD-drive to USB
- Stereo Headphone output

Description	Code	Price (Ex VAT)
DUS-1	232-040	£265.83

FOR
fax orders

Use our fax number...

020 8450 4390

1000s
of products
Available from stock!

DELIVERY BEFORE NOON
no problem

SATURDAY DELIVERY
no problem

Tascam CD-200iL

CD Player/iPod Dock



Includes features such as pitch control with an on/off knob, a headphone output with level control, intro check, anti-shock memory, and a variety of convenient playback modes.

- MP3/MP2 and WAV CDs. ±14 % pitch control
- Lightning and 30-pin dock connectors provided
- CD text and ID3 tag support to display artist and track details
- Time display (CD-DA: Elapsed, Remain, Total Remain; MP3: Elapsed)
- Outputs, Headphone, SPDIF coaxial and optical

Tascam CD-200BT

CD Player/Bluetooth Receiver



CD Player with playback from other audio sources via AUX IN connector.

- Internet radio or network file playback via a Bluetooth connection with a smartphone or computer
- Folder selection for MP3 and WAV CDs
- Continuous, Random and Program playback modes
- CD text and ID3 tag support to display artist and track details
- Time display (CD-DA: Elapsed, Remain, Total Remain; MP3: Elapsed)
- ±12.5 % pitch control
- SPDIF digital outputs (coaxial and optical)
- Wireless remote control included

Description	Code	Price (Ex VAT)
CD-200iL	238-450	£290.83
CD-200BT	238-460	£240.83

Tascam CD500

Pro 1U CD Player



The CD-500 is an extremely compact CD player available as a standard or professional version.

- Flash start capability for up to 20 tracks
- Auto cue, auto ready, intro check functions
- CD500B similar to CD500, but with XLR balanced outputs, AES/EBU digital I/O and parallel control.

Description	Code	Price (Ex VAT)
CD500	238-070	£422.00
CD500B	238-080	£495.00

Newhank BDP-620

Blu-Ray DVD/USB/CD Player



Solution for Playback of Blu-rays and other popular Media Formats from Disk or USB.

- Disk tray loader with Sony Laser
- Supported Disk formats: BDMV, BDAV, BD-ROM2.0, BD-R/RE, DVD-VIDEO, DVD-R/+R, DL, CD-DA, CD+G, DTS-CD, VCD, SVCD, CD-R/RW
- Supported file formats: MKV, MP4, MP3, AVI, MT2S, VOB, FLV, MPG, JPG
- Supported codecs: H.264, VC-1, MPEG-1/2/3/4, Xvid, DTSMA, DTS
- Outputs for L/R audio on RCA and Optical SPDIF
- Outputs for video on HDMI 1.3 and Composite on RCA
- LAN Connector for BD LIVE
- Supplied with infra red remote control (2xAAA battery included)

Description	Code	Price (Ex VAT)
BDP-620	232-050	£165.83

Stageline CD156

Stereo CD Player



Stereo CD player for HiFi and PA applications.

Double suspended, dampened player mechanism. Title programming, repeat function (repeat 1, repeat all), random replay, standard operating functions. Adjustable headphone output. Infrared remote control with direct title selection. 482mm (19") rack installation with supplied mounting brackets, 2RS (rack spaces). Audio CD/CD-R.

Description	Code	Price (Ex VAT)
CD156	260-310	£115.83



Stageline CD-112

Dual CD/MP3 Player



CD and MP3 player with USB interface and SD/MMC card slot suitable for all professional applications.

- USB storage media can be connected directly
- For SD/MMC cards up to 32GB (FAT16/FAT32), available at option
- Anti-shock system, Autoplay function, Fast forward and reverse
- Supports ID3 tags
- Track programming
- CD-112/BT - Same as CD-112, but with Bluetooth receiver

Description	Code	Price (Ex VAT)
CD-112	256-590	£199.00
CD-112TRS	256-600	£225.00
CD-112/BT	256-830	£222.50

Denon DN-501C

CD Media Player



A bright, highly visible OLED display, a slot-in CD Data drive and USB port for playback with pitch and master key control.

- Supports CDDA/WAV/MP3/AAC/AIFF audio file formats
- USB mass storage device playback
- Direct digital playback of iPod/iPhone via USB
- OLED high contrast display. Slot-in CD drive
- +16% (0.1% step) pitch control for CD and USB
- Supports copying CD data to USB storage as WAV file (ripping)

Description	Code	Price (Ex VAT)
DN-501C	271-900	£479.00

Newhank Workmate

2U 19" Compact Mixer Media Player



A complete stereo mixer/pre-amplifier and smart media player in a compact package.

- Compact 2u low noise audio design
- 4 Line control channels plus separate Mic section
- 2 stereo phono, 7 stereo Line and 3 Mic inputs
- 2-band equalizer per channel
- Stereo Master audio out on both RCA and balanced XLR
- Balanced stereo Booth output on 6.3MM connectors
- Select play from USB, SD (both max 32GB) and thru Bluetooth

Newhank Playmate

4U 19" Stereo Mixer Media Player



Professional 4HE 19" stereo rack mixer and media player.

- Select play from USB, SD (max 32GB) and Bluetooth
- Plays both WAV and MP3 files
- Compact 4u low noise audio design
- 4 Line control channels plus separate microphone section
- 2 phono/line, 6 stereo Line and 3 microphone inputs
- 3-band equaliser per channel (-30dB/+10dB)
- Replaceable assignable crossfader

Description	Code	Price (Ex VAT)
Workmate	232-020	£220.83
Playmate	232-030	£270.83

Media Players

Denon DN-700C

Network Media CD Player



Complete with a front USB port for mass storage devices and iPod® playback.

- Offers connectivity to the latest sources of music files
- Streams audio over the network (DLNA)
- Supports playback of CD-DA, WAV, AIFF, MP3 & AAC files
- USB device (mass storage class) and iPod playback
- Large, bright OLED display
- Balanced XLR audio output. AES/EBU digital format output
- Pitch control playback allows adjustment of the playback speed between -16% to +16% in 0.1% steps
- End Monitor and User-selectable Finish Mode features
- Included DENON Professional Product Manager software

Description	Code	Price (Ex VAT)
DN-700C	271-880	£573.00

DELIVERY BEFORE 10AM no problem

USB/SD Players

PLAYERS

Denon DN-F300

Stereo SD Card Player



The Denon DN-F300 further raises the bar with digital solid-state design that features no moving parts and unparalleled reliability.

- 2 x SD card slots and 1 x USB port
- Pitch bend
- 19" Rack Mountable 2U
- Seamless looping
- Fast track search

Denon DN-F400

Stereo SD Card Player



Ideal for use in public facilities requiring continuous playback, repeated programmed audio messaging or quickly-triggered announcements.

- Plays WAV and MP3 files
- Uses SD and SDHC cards
- Balanced and unbalanced outputs
- Headphone output
- Securable SD slot
- Simple, intuitive operation

Description	Code	Price (Ex VAT)
DN-F300	271-750	£207.50
DN-F400	271-760	£312.50

Denon DN500R

SD/USB Recorder



Records to SD/SDHC and USB media in MP3 and WAV (up to 24-bit/96kHz).

- Two record mediums can be used simultaneously with the Dual Record feature
- Relay Record (continues recording to backup media when primary media is full)
- XLR and RCA audio connections (analogue and digital)
- MP3, WAV, AIFF, AAC playback. RS-232c, GPIO, USB keyboard remote control
- Front panel USB keyboard connection
- EDL marking & file edit functions
- Record Monitor (listen the recorded signal while recording)

Denon DN700R

Network SD/USB Recorder



The unit can be configured for 'dual' simultaneous recording to both formats or 'relay/cascade' recording where longer recording times are desirable.

- Records to SD/SDHC and USB media in MP3 and WAV
- Dual Record feature and Relay Record feature
- Web Remote for setup and control with Password Protection
- Independent switchable XLR Mic/Line inputs with +48V Phantom Power. Timer recording/playback (30 schedules available)

Description	Code	Price (Ex VAT)
DN500R	271-910	£549.00
DN700R	271-920	£665.00

Roland CD-2U

SD/CD Recorder

Completely self contained with stereo microphones and speakers.

- Records direct to CD-R/RW discs or SD/SDHC memory card
- External stereo microphone inputs
- XLR/TRS inputs with phantom powering
- Stereo line inputs/outputs on RCA Phono
- Adjustable playback speed
- Built-in tuner and metronome
- Wireless remote control included
- Center Focus isolates vocals and instruments for learning



Description	Code	Price (Ex VAT)
CD-2U	309-980	£440.83

CDR Professional

MEDIA

HHB CDR74 Gold

CDRs

HHB's original audio optimised 1X to 8X disc.

- Designed for use in the single-speed writers used in audio CD recorders
- 74 minute / 650MB CD-R disc
- Advanced phthalocyanine dye
- High reflectivity, low jitter performance
- 100 year secure archival life
- Tough protective coating



Description	Code	Price (Ex VAT)
CDR74 Gold x1	123-100	£2.72
CDR74 Gold Pack of 10	123-110	£25.40

HHB CDR80 Silver

CDRs

Silver reflective layer increases reflectivity, resulting in widespread compatibility with CD recorders and players.

- Uses ultra stable Phthalocyanine dye resulting in a recording layer with a projected life exceeding 100 years
- Full Orange Book Part II compatible



Description	Code	Price (Ex VAT)
CDR80 Silver x1	123-210	£0.85
CDR80 Silver Pack of 10	123-220	£7.44

Sony Imation Cakebox CDR80*

CDRs



25 and 100 pieces of 700MB/80 minute Imation CDR 48x speed in a Cakebox. No jewel cases supplied.

Description	Code	Price (Ex VAT)
25 CD Cakebox	142-020	£5.95
100 CD Cakebox	142-120	£15.82

*May be replaced by an alternative quality brand.

HHB CDR80 Silver IP
Inkjet Printable

Printable version of the HHB CDR80 which is popular with recordists and archivists.

Audio - optimised and intended for use in single speed professional audio recorders. Has a white disc surface optimised for use with inkjet printers including models from Affex, Copytrax, Fargo and IMT. Packed in jewel cases.

Description	Code	Price (Ex VAT)
CDR80IP Single	123-320	£0.89
CDR80IP 10 Pack	123-330	£7.94
CDR80IP Cakebox 50	123-270	£18.70

HHB CDR80Bulk Cakebox

Thermal Printable

Printable version of the CDR80 with a matt white disc surface optimised for use with thermal printers.

Description	Code	Price (Ex VAT)
CDR80Bulk Cakebox 50 Pack	123-340	£18.70



DELIVERY BEFORE NOON
no problem

SATURDAY DELIVERY
no problem

DELIVERY BEFORE 10AM
no problem

Verbatim Vinyl Style CDRs

CDRs

The White Inkjet and Vinyl surface is a Retro disc which looks like a vinyl record.

- White surface for inkjet printing to personalise discs
- Superior resistance to UV irradiation.
- Archival Life: Extra Protection - up to 40 years; AZO - up to 100 years
- Capacity: 700MB
- Speed: 52x
- Pack Style: 10/25 Pack Spindle
- Disc Surface: Data Vinyl Printable
- Print Area: 23 - 70mm



Description	Code	Price (Ex VAT)
CDR x25	124-440	£8.32
CDR x10	124-450	£4.16

Sony Imation CDR80 Slims x10*

CDRs

10 pieces of Imation's popular 80 minute/ 700MB CDRs in slim jewel cases.

- Plain discs (not coloured as before)
- Currently 52x speed
- The same high quality as the market-leading Sony Imation Reflex CDRs



Description	Code	Price (Ex VAT)
CDR80 Slims x10	142-110	£3.52

*May be replaced by an alternative quality brand.

CDR Consumer Type

Fuji CDR Audio*

CDR Consumer Type

Delivers bit-perfect recording and playback precision for accurate music storage and reproduction.

- 80 minutes
- 700MB capacity
- For use on CD recorders which require the SCMS code in the disk
- Some older CD recorders may not be suited for use with 80 minute CDRs.



Description	Code	Price (Ex VAT)
CDR80 x1	122-550	£0.62
CDR80 Pack of 10	122-600	£5.88

*May be replaced by Sony Imation or an alternative quality brand.



DVD - Recordable

Imation DVD+Rplus DVD-Rminus 4.7GB

Cakebox GP

50 pieces of 4.7GB TDK DVD+R & DVD-R in a Cakebox.

- No Jewel cases supplied



Description	Code	Price (Ex VAT)
DVD+R 4.7 x50	142-170	£12.20
DVD-R 4.7 x50	142-160	£12.20

HBB DVD-R4.7GB

DVD-R

General purpose white inkjet-printable DVDs in a cakebox.

- No cases provided
- 1x - 8x write speed
- Pack of 50 discs
- Available in Inkjet printable discs



Description	Code	Price (Ex VAT)
Inkjet Printable x50	123-420	£24.90

Memory Cards

Integral MicroSDHC Class 4/Class 10

Micro SDHC

Upgrade your multimedia device with an Integral microSDHC memory card.

- High quality Integral memory card for portable recorders, mobile phones and other multimedia devices
- Up to 32GB capacity for storing digital data
- Class 4 specification provides more than 4MB/sec continuous write speed. Class 10 more than 10MB/sec



Description	Code	Price (Ex VAT)
Class 4 4GB	137-500	£3.32
Class 4 8GB	137-510	£4.96
Class 4 16GB	137-570	£8.30
Class 4 32GB	137-770	£14.90
Class 10 4GB	137-890	£3.96
Class 10 8GB	137-900	£4.99
Class 10 16GB	137-910	£9.50
Class 10 32GB	137-920	£16.50

Integral SDHC Card

Class 4 + 6

High storage capacity (4GB upwards) and fast data transfer.

- Store your digital content such as MP3's, high-resolution photos, high definition videos
- Without the restrictions of memory card size and data write-speeds of the past



Description	Code	Price (Ex VAT)
SDHC 4GB Class 4	137-370	£4.13
SDHC 4GB Class 10	137-390	£3.96
SDHC 8GB Class 4	137-440	£4.95
SDHC 8GB Class 10	137-530	£5.62
SDHC 16GB Class 4	137-460	£7.28
SDHC 16GB Class 10	137-540	£7.85
SDHC 32GB Class 4	137-490	£12.90
SDHC 32GB Class 10	137-560	£14.92

Pen Drives

INFO message

Memory Card Prices

Pen drives, plus SD, SDHC, and other card prices are still very volatile, with some going down 50% over the last 12 months. Then occasionally the prices bump up again! Please check online for latest pricing, while for larger orders call for the best price.

Integral Splash USB 8.0/32.0

Pen Drive

Perfect for moving files between school, office and home!

- Hi Speed USB 8.0 / 32.0 pen drive
- Shock proof and water proof rubberised casing
- Read speed: 12MB/s, write speed: 3MB/s
- Lightweight and slim design
- Choice of colours



Description	Code	Price (Ex VAT)
8GB - Blue	137-640	£5.82
8GB - Yellow	137-650	£5.82
8GB - Pink	137-660	£5.82
8GB - Black	137-670	£5.82
32GB - Black	137-840	£14.98

WANT a job?

Are you looking for a stable and rewarding career?

Studiospares are constantly expanding. We require additional staff for a variety of positions, working in a very congenial atmosphere. Practical experience of recording and/or live sound engineering would be preferable.

send in your CV in the first instance

PRICE changes

This catalogue was priced on 1st December 2014.

Current prices may be higher...

see our website for up to date prices.

THE website

Keep up to date with all the latest products and current prices on the Studiospares website!

check out www.studiospares.com

Pen Drives

MEDIA
CONTINUED

Integral Neon USB 3.0 Orange

Pen Drive

The Integral Neon flash drive will back-up, transfer and access your digital content 10X faster than ever.

- Faster data transfer up to 10x the normal USB 2.0 drive
- Eye-catching fluorescent casing
- HD movies, back-ups and upgrading PC systems
- Backwards compatible with USB 2.0



Description	Code	Price (Ex VAT)
8GB	137-850	£5.75
16GB	137-860	£8.30
32GB	137-870	£14.15
64GB	137-880	£24.90

Verbatim V3 USB 3.0

16GB Pen Drives

Up to 10 times faster than USB 2.0* making it faster for transferring and saving larger file sizes of all types.

- USB 3.0 SuperSpeed Interface.
- 'Slide and Lock' mechanism protects the USB connector when not in use
- Compact, stylish design.
- Colours available: Eucalyptus Green, Caribbean Blue, Violet, Black



Description	Code	Price (Ex VAT)
Black	124-400	£8.32
Green	124-410	£8.32
Violet	124-420	£8.32
Blue	124-430	£8.32

Integral USB 2.0 High Speed

Pen Drive

Useful and portable pen drives for use with Mac or PC...

- For use with Mac or PC
- USB 2.0 and 1.1 compatible.
- Featuring red LED
- Weight 9g
- Supplied with a USB extension lead, neck holder and Windows driver disc



Description	Code	Price (Ex VAT)
4GB	137-180	£4.15
4GB 10-Pack	137-181	£37.50
8GB	137-190	£5.52
16GB	137-200	£8.72
32GB	137-210	£14.45
64GB	137-230	£24.99

MORE PRODUCTS online

Card Readers

MEDIA

Integral 9-In-1

Card Reader

USB adaptor that allows 9 types of memory card to be read by your computer.

- Mac and PC compatible
- Reads the following format cards: SD Card, Mini SD Card, Micro SD (TransFlash), R5MMC, DV-R5MMC, MMC Mobile, MMC, MMC Plus, Memory Stick - MS-Pro, MS-Duo and MS-ProDuo



Description	Code	Price (Ex VAT)
9-In-1 Card Reader	137-260	£4.55

Integral 17-In-1

Multi Card Reader

USB Card reader that will read 17 types of memory card.

- Mac and PC compatible
- Reads the following format cards: Compact Flash, SD, Mini SD, xD, MMC, MMCplus, SmartMedia, Microdrive, Magicstor Drive, MemoryStick, MemoryStick Pro, MemoryStick Duo & PRO Duo, RSMMC, MMCmobile. With an adaptor will also read Transflash/Micro SD & MMC Micro.



Description	Code	Price (Ex VAT)
17-In-1 Card Reader	137-270	£5.30

Minidiscs

MEDIA

HHB Minidisc 80

Minidiscs

Precision manufactured and tested to exacting tolerances.

- Achieves block error rates more than 10 times lower than consumer MiniDiscs
- Can be used reliably for more than 1 million read/write cycles
- Tough UV coating protects the tape
- Special lubricating agent resists dust contamination
- Slip case with a quick release security lock ensures quick access



Description	Code	Price (Ex VAT)
MD80 80 Minutes	123-250	£1.87

Sony PRMD74 Pack Of 5

Professional Minidisc

Offers superior quality of digital recording with the convenience of instant access.

- Reliable media for audio archives
- Quick Random Access
- Extremely low error rate unaffected by one million erase / read / write cycles
- CD-type case, with professional index sheet and label sheet
- Pack of 5



Description	Code	Price (Ex VAT)
PRMD-74 x5	127-370	£11.99

Tape

MEDIA

HHB DTRS Tape

113 minute DTRS tape approved by Tascam for all DTRS recording applications.

- Double coated for high output and low block error rates
- Advanced binder compound for increased durability
- Rigid, heat resistant shell
- Secure archival life in excess of 10 years



Description	Code	Price (Ex VAT)
DA60 60 minutes	123-300	£7.52
DA113 113 minutes	123-090	£9.80

RMG Magnetic Tape

Formed out of the media giant Philips in Holland who had the plant and technology to produce tape with quality and consistency.

- Produces two Quantegy bias compatible tapes
- High bias, high output SM900 replaces 499 and GP9, lower bias and output
- SM911 replaces Quantegy 456

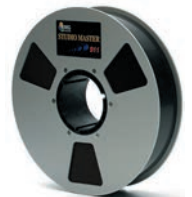

Description	Code	Price (Ex VAT)
SM900 1/4" NAB Spool	119-100	£40.50
SM900 1/2" NAB Spool	119-110	£56.08
SM900 1" NAB Spool	119-120	£95.83
SM900 2" NAB Spool	119-130	£174.17
SM911 1/4" NAB Spool	119-000	£39.58
SM911 1/2" NAB Spool	119-010	£58.25
SM911 1" NAB Spool	119-020	£101.25
SM911 2" NAB Spool	119-030	£165.83

Hard Drives

MEDIA

Verbatim 500GB USB 3.0

2.5" Hard Disk Drive

Transfer documents and data easily between home and office.

- USB 3.0 Super Speed data transfer
- Safely back up and store all your files from your PC or laptop
- USB plug 'n' play (no additional power required)
- Stylish slim design fits neatly onto your desk top and allows it to be transported easily
- 'Nero BackUp Essentials' software - create your own 'back up' from your PC/Laptop hard drive to your portable hard drive



Description	Code	Price (Ex VAT)
500GB Hard Disk Drive	128-780	£55.00

FOR fax orders

Use our fax number...

020 8450 4390

Verbatim External Hard Drives

Huge storage capacities available with Verbatim's new range of desktop hard drives - includes back-up software and 2 year warranty.

2.5" USB

Ideal storage solution for people on the move.

- USB plug 'n' play
- Stylish slim design
- 'Nero BACKITUP 4 Essentials' back up software
- Compatible with Windows Vista
- 2 year limited warranty
- USB 2.0 buss powered



3.5" USB 2.0 7200RPM

High capacity storage back up for all file types.

- Sleek 'black steel' space saving design for the desk top
- Hi-speed USB 2.0 interface
- Store thousands of digital photos, videos, MP3s
- 'Nero BackitUp and Burn Essentials' software
- Desktop version requires AC Power Supply Unit (supplied)
- Compatible with Windows Vista

Description	Code	Price (Ex VAT)
250GB USB 2.5	128-710	£42.50
500GB USB 3.0	128-780	£55.00
1TB USB 2.5	128-790	£99.70
500GB USB 3.5	128-740	£73.06
1000GB USB 3.5	128-750	£115.10
1.5TB USB 3.5	128-760	£93.50
2TB USB 3.5	128-770	£99.70

MEDIA

Cassettes

TDK/Maxell Ferric 90

Cassette

A ferric cassette which has outlasted the competition.

- Low friction rollers
- Antistatic liners
- Record inhibit tabs
- Normal ferric biasing
- Highly reliable



Description	Code	Price (Ex VAT)
Ferric 90	142-240	£0.99

MEDIA

Media Accessories

Spare CD Cases

Standard CD Cases as used by the record companies. Packs of 10 or 200.



Description	Code	Price (Ex VAT)
Pack of 10	127-390	£3.56
Pack of 200	127-640	£34.03

CD Wallets Plastic 10/100 Packs

- Basic clear plastic wallet for CDs
- Open one end with flap to secure CD
- Sold in packs of 10 or 100



Description	Code	Price (Ex VAT)
Pack of 10	127-920	£0.85
Pack of 100	127-930	£7.20

Isopropyl Alcohol 100ml

The industry's most sought after head cleaning agent.

- For cleaning rubber components apply on a cloth
- 99% pure alcohol (if it were 100% pure it would immediately evaporate)
- Highly inflammable.



Description	Code	Price (Ex VAT)
Isopropyl Alcohol 100ml	126-000	£2.34

CD/DVD Markers

CDR Pens

Permanent marker pens are ideal for writing on CDR and DVDR discs.

- Soft fine tip that won't damage the disc surface
- Includes 4 CD/DVD pens
- Red, Black, Blue and Green
- Non-toxic, water based ink
- Permanent markers



Description	Code	Price (Ex VAT)
CD/DVD Markers	127-000	£3.25

MIXERS

Broadcast Consoles

Sonifex 50

Radio Broadcast Mixer

A user friendly fixed format radio broadcast mixer with USB for recording.

- Ideal for community and internet radio stations
- Telephone hybrid for making and recording on air calls
- Built-in limiter for hearing protection
- Studio speakers mute & automatic mic live sign switching
- 4 mic, 12 stereo line, 1 TBU & 1 stereo auxiliary inputs



Sonifex S1

Radio Broadcast Mixer

Added flexibility on and off air with the easy to use, compact, low cost, fixed format radio mixer.

- Analogue & digital inputs and outputs (remote outputs per channel)
- Main stereo output buss plus 2 Aux output busses, pre or post fader selectable
- Programmable general purpose I/O. Monitor muting on mic live/on-air sign switching
- Telephone hybrid for making and recording on air calls



Description	Code	Price (Ex VAT)
S0	368-290	£1666.00
S1	368-300	£2166.00

Digital Mixers

MIXERS

Presonus StudioLive AI Series

Digital Mixers



With a powerful user interface, unrivalled sound quality, amazing DSP performance, direct Wi-Fi and LAN communication, fast and intuitive workflow, onboard FireWire 800 interface, and tightly integrated software suite for Mac®, Windows®, and iOS®, StudioLive™ AI-series digital mixers create a streamlined working environment for both live and studio use. Class A preamplifiers deliver more headroom, deeper lows, smoother highs, and a richer overall sound than the preamps found in competing mixers. High-headroom, 32-bit floating-point processing is used for all digital mixing. The high-end Burr-Brown digital converters on every input and output are state-of-the art, with 118 dB dynamic range. Four programmable, 32-bit, stereo DSP effects engines—two of them loaded with reverbs and two armed with delay effects that you can really use. Each stereo processor has its own dedicated internal FX bus. Each channel and bus has its own studio-grade compressor, limiter, gate/expander, and 4-band parametric equalizer. Each input channel, aux and FX bus also has a highpass filter, and input channels have polarity invert. StudioLive AI-series mixers start with all the strengths that made the first generation of StudioLive mixers famous: powerful, surface-driven interface; loads of DSP processing and analogue I/O; and layerless mixing, thanks to dedicated mix buses. So while the three StudioLive AI-series mixers — the StudioLive 32.4.2AI, 24.4.2AI, and 16.4.2AI—look and feel much like their non-AI counterparts.

Description	Code	Price (Ex VAT)
16.4.2AI 16 Channels	328-650	£1415.83
24.4.2AI 24 Channels	328-660	£1815.83
32.4.2AI 32 Channels	328-630	£2790.83

Mackie DL1608

Digital 16-Track Live Mixer

Transforms your iPad into a 16-track digital live mixer with the added analogue Mackie sound.

- Multiple screen iPad app for fader control
- EQ, compression & gate settings
- Access to reverb, delay and a 31-band master EQ
- 16 Onyx mic preamps
- 24 bit Cirrus Logic AD/DA converters
- Lightning connector version available



Description	Code	Price (Ex VAT)
DL1608	262-440	£649.17
DL1608 Lightning	262-445	£732.50

VISIT
our trade counter
You'll get friendly advice and immediate access to 8000+ product lines!

1000s
of products
Available from stock!

Digital Mixers

MIXERS

CONTINUED

Behringer X32

Digital Mixing Console

**BEST
SELLER**

The World's Most Popular
Digital Mixer.



Lets you focus on your event,
instead of navigating a vast sea
of knobs, buttons and menus like
some live digital mixers.

Intuitive and powerful with 40 processing channels and 25 mix buses, all equipped with dynamics and EQ, which can be configured quickly. Use any combination of the local 32 console mic inputs or the networked digital snake inputs on stage—their audiophile quality programmable preamps always ensure full control, purity and impeccable dynamics. The dedicated channel strip section puts 17 backlit buttons and 13 rotary controls with LED-collars right at your fingertips for nuanced adjustment of each channel's compressor, 4-band parametric EQ and much more. I/O abounds with 32 high-end programmable mic preamps; 6 Aux Inputs on 1/4" TRS; 16 balanced XLR Outs, plus balanced Control Room outputs on both XLR and 1/4" TRS connectors. A single CAT5 cable from FOH to the stage can receive up to 48 channels of audio input—and deliver all bus outputs, along with 16 individual monitor feeds for Behringer's brand new P16 personal monitoring system. The onboard virtual FX Rack provides access to eight true-stereo, multi-effects processors (16 mono) including delay, chorus, dynamics—and it can run 4 production quality true-stereo reverbs concurrently with 8 channels of 31-band graphic equalization.

**WINNER
'BEST MIXING
DESK (LIVE)'
MIPA 2013**

**WINNER
'READER'S
CHOICE AWARD'
NAMM 2013**

**WINNER
'BEST DIGITAL
MIXING CONSOLE'
WFX 2013**

**WINNER
'BEST MIXING
CONSOLE'
MUSIKMESSE 2014**

Key features:

- 40-input channel, 25-bus digital mixing console
- 32 MIDAS- designed, fully programmable mic preamps
- 25 Fully automated motorized 100 mm faders
- 16 XLR outputs plus 6 additional line in/outputs
- 32 x 32 channel X-USB audio interface over USB 2.0
- High-resolution 7" day-viewable Color TFT
- Main LCR, 6 matrix buses and 16 mix buses
- Virtual FX rack featuring 8 true-stereo FX slots
- 40-Bit floating-point DSP
- 48-channel Digital Snake ready via AES50 ports

Description	Code	Price (Ex VAT)
X32	382-820	£1499.17
X32 + S16 Digital Snake	382-824	£1999.17
X32 + Mixer Case	382-825	£1612.50
X32 + Gooseneck Light	382-826	£1508.33

Description	Code	Price (Ex VAT)
X32 + M1000 Headphones	382-827	£1529.17
X32 + S16 + Case	382-828	£2112.50
X32 + 2x S16 + Case	382-829	£2612.50

Description	Code	Price (Ex VAT)
X-UF USB/FW Card for X32	384-061	£220.83
X-ADAT ADAT Card for X32	384-062	£199.17
X-MADI MADI Card for X32	384-063	£220.83
X-DANTE Card for X32	384-065	£315.83

Behringer X32 Compact

Digital Mixing Console

Compact 40-input channel, 25-bus digital mixing console for Studio and Live application.



16 Programmable MIDAS Preamps, 17 Motorized Faders, Channel LCD's, Audio Interface and iPad/iPhone Remote Control. 17 Fully automated motorized 100 mm faders. Individual and dynamic LCD Scribble Strips on all channels and buses. 32 x 32 channel USB 2.0 audio interface, with DAW remote control emulating HUI and Mackie Control. Free iPad and iPhone apps for remote operation. Main LCR, 6 matrix buses and all 16 mix buses each featuring inserts, 6-band parametric EQs and full dynamics processing, plus 8 DCA and 6 mute groups. Networked remote control for show setups with on-screen software editor via Ethernet. Built-in expansion port for audio interface cards or digital networking bridges. ULTRANET connectivity for Behringer's P-16 Personal Monitoring System plus AES/EBU stereo digital output and MIDI.

Key features:

- 40-input channel, 25-bus digital mixing console
- 16 MIDAS- designed, fully programmable mic preamps
- 17 Fully automated motorized 100 mm faders
- 8 XLR outputs plus 6 additional line in/outputs
- Main LCR, 6 matrix buses and 16 mix buses
- 32 x 32 channel X-USB 2.0 audio interface

Behringer X32 Producer

Digital Mixer

Powerhouse features in a rock solid form factor.



Processing power, ample I/O and flexible routing are central themes in the X32 Producer. Where larger consoles make sense in fixed installations or studios, with the X32 Producer, studio-calibre performance now goes wherever life takes you. Eight stereo effects engines provide the signal processing power equivalent to racks of outboard gear without having to haul anything besides the X32 Producer. 40-input channel, 25-bus rack-mountable digital mixing console for Studio and Live application. 16 MIDAS-designed, fully programmable mic preamps for audiophile sound quality. 8 XLR outputs plus 6 additional line in/outputs, a phones connector and a talkback section with XLR mic input. 32 x 32 channel USB 2.0 audio interface, with DAW remote control. Main LCR, 6 matrix buses and all 16 mix buses each featuring inserts, 6-band parametric EQ and full dynamics processing.

Key features:

- 40-input channel, 25-bus rack-mountable digital mixing console
- 16 MIDAS- designed, fully programmable mic preamps
- 17 Fully automated motorized 100 mm faders
- 8 XLR outputs plus 6 additional line in/outputs
- Main LCR, 6 matrix buses and 16 mix buses
- 32 x 32 channel X-USB 2.0 audio interface

Behringer X32 Core

Digital Mixer

Condenses the brain of the flagship X32 digital mixing console into a single rack space.



Combine the X32 CORE with the S16 digital snake to effortlessly run sound with high I/O counts in multiple locations. Dual AES50 networking CAT5 connectors allow for up to 96 remote inputs and 48 output channels to be controlled from and processed by the X32 CORE. All of this can be managed concurrently from various locations and instances of the free control software applications, XiQ, XiControl and XControl. 40-input channel, 25-bus, 1U rack-mountable, 32 x 32 channel USB 2.0 audio interface. Main LCR, 6 matrix buses and all 16 mix buses inc inserts, 6-band parametric EQ, full dynamics processing, 8 DCA and 6 mute groups. Virtual FX rack featuring 8 true-stereo FX slots.

Key features:

- 40-input channel, 25-bus 1U digital rack mixer
- 48-channel Digital Snake ready
- 32 x 32 channel X-USB 2.0 audio interface
- 2 TRS outputs for local monitoring
- Main LCR, 6 matrix buses and 16 mix buses
- Virtual FX rack featuring 8 true-stereo FX slots

Behringer X32 Rack

Digital Mixer

The ideal choice for handling audio now – and as your needs grow.



It can be your top-notch studio recording interface today, control a complex theater production tomorrow, or sit securely in your side-rack while you're mixing your school's show from your iPad. The X32 Rack is a revolutionary new product genre that combines finest analogue I/O and powerful digital connectivity, with ample processing for 40 channels, 25 buses and up to 152 signal sources. 16 MIDAS-design mic preamps provide plenty of inputs—and with its dual AES50 ports, X32 RACK can support up to six S16 digital snakes for massive I/O connectivity. 8 powerful stereo FX engines coupled with ultra-flexible routing options make the X32 Rack a great choice for your educational shows.

Key features:

- 40-input channel, 25-bus 3U rack-mountable digital mixer
- 16 MIDAS- designed, fully programmable mic preamps
- 48 channel Digital Snake ready
- 40 Bit floating-point DSP
- Main LCR, 6 matrix buses and 16 mix buses
- Virtual FX rack featuring 8 true-stereo FX slots

Studiospares Trojan X32 Case

Mixer Case

Professional grade mixer case specifically designed for the Behringer X32.



- Constructed from 9mm plywood and aluminium and built to a high standard
- The plywood has been covered with a layer of laminated plastic
- Lid secured using 4 butterfly latches

Studiospares Trojan X32 Wheeled

4 Drawer Case

Designed specifically for the Behringer X32 and accessories.



- 4-Wheels, 4-lockable drawers for accessories and a lift off lid
- Constructed from 9mm plywood faced with a tough and attractive Black Phenolic surface
- Corners are protected by chrome plated steel bumpers
- Catches fully retract

Gator G-Tour X32

X32 Case

Features a thick, 12mm heavy duty plywood construction and a tough laminated PVC exterior.



- Unique design which provides easy cable routing and full rear access
- Spring loaded carrying handles
- Specialised EVA foam padding
- Detachable lids/heavy duty castors
- External dimensions mm: 1008W x 925L x 280H; Weight 47kg

Description	Code	Price (Ex VAT)
X32 Compact	383-900	£1162.50
X32 Compact + S16 Snake	383-904	£1662.50
X32 Compact + Case	383-905	£1245.83
X32 Compact + S16 + Case	383-908	£1745.83
X32 Compact + 2x S16 + Case	383-909	£2245.83
X32 Producer	384-040	£925.00

Description	Code	Price (Ex VAT)
X32 Producer + S16 Snake	384-044	£1457.50
X32 Core	383-910	£540.83
X32 Core + S16 Snake	383-914	£999.00
X32 Core + S16 + Case	383-915	£1049.00
X32 Core + 2x S16 + Case	383-916	£1525.00

Description	Code	Price (Ex VAT)
X32 Rack	384-050	£857.50
X32 Rack + S16 Snake	384-054	£1385.00
Trojan X32 Case	458-790	£140.00
Trojan X32 Wheeled Case	458-720	£270.00
G-Tour X32 Case	471-200	£299.00

Digital Mixers

MIXERS

CONTINUED

Allen & Heath Qu Series

Digital Mixers

Combine exceptional ease of use with class-leading audio performance.

With its responsive touchscreen, motor faders and acclaimed AnalogiQ recallable preamps, the Qu Series take compact digital mixing to a new level. Drawing on the technologies and workflow pioneered on our GLD and iLive touring systems, Qu makes Allen & Heath digital mixing more accessible and more compact than ever. Qu's AnalogiQ total recall preamps feature zero crossing detection and an advanced padless 1dB step gain stage, closely allied to the DSP for optimal gain accuracy and audio transparency. Qu-16, Qu-24 and Qu-32 feature 16, 24 and 32 motorized ALPS faders respectively, arranged over 2 layers, allowing instant access to all channels and masters in a compact space. Forget soundcard drivers and software setup. Qu has an integrated multitrack USB recorder, providing 18 channels of 48kHz, 24bit recording and playback straight to / from your USB hard drive.



Description	Code	Price (Ex VAT)
Qu-16 16 In / 12 Out	269-580	£1415.83
Qu-24 30 In / 24 Out	269-620	£1832.50
Qu-32 38 In / 28 Out	269-640	£2207.50

ALLEN & HEATH

Yamaha O1V96i

Digital Mixer

Includes the latest version of Steinberg's Cubase AI, the full suite of Yamaha's acclaimed Virtual Circuitry Modeling DSP effects and newly improved studio-quality head amps.

- 16 in/16 out USB 2.0 audio streaming at an impressive 96kHz
- 96kHz Multi-Track Live Recording with a Single Connection
- 96kHz Internal Effects and Top-Quality Compression, Gating and Delay
- 5 models of Channel Strip
- Master Strip employs VCM technology



Description	Code	Price (Ex VAT)
O1V96i	274-570	£1270.83

Soundcraft SI Performer Series

Digital Mixers

Bring unparalleled mix power and performance to small format digital live sound mixers.

- 8 line inputs
- 80 channels to mix
- 2 ViSi Connect™ option card slots for 128 x 96 input/output paths
- Pre/Post selection per input per bus
- Freely assignable faders and patching
- 20 sub-group / aux busses
- 4 FX busses
- 8 Matrix busses
- LRC Mix busses
- LCR panning
- 4 Stereo Lexicon Effects engines



Description	Code	Price (Ex VAT)
Performer 1 - 16-Channel	268-010	£2707.50
Performer 2 - 24-Channel	268-020	£3332.50
Performer 3 - 32-Channel	268-030	£3957.50

Allen & Heath AB168

Portable Stage Box

Provides 16 XLR inputs and 8 XLR outputs when connected to a GLD-80 or GLD-112 mixer, or to an AR2412 AudioRack.

- Connects over a single Cat5 cable via a secure dSNAKE EtherCon port
- 16 Mic Preamps on XLR
- Phantom Power LED per Input
- 8 XLR Line Outs
- dSNAKE Connection with locking Ethercon port
- Rubber bumpers
- Carry handle
- Optional rack mount kit available



Description	Code	Price (Ex VAT)
AB168	269-650	£765.00

Soundcraft SI Expression Series

Digital Mixer

This series exploits some of the newest DSP, component technology and manufacturing techniques to deliver their most powerful cost effective digital console ever.

- 16 recallable mic pre amps, 4 line inputs, 4 internal stereo FX returns
- AES in, and a 64x64 expansion slot
- **Expression 2** - 24 recallable mic pre amps, 4 line inputs, 4 internal stereo FX returns; AES in, and a 64x64 expansion slot
- **Expression 3** - 32 recallable mic pre amps, 4 line inputs, 4 internal stereo FX returns; AES in, and a 64x64 expansion slot
- Please see our website for more information on features



Description	Code	Price (Ex VAT)
Expression 1	267-960	£1832.50
Expression 2	267-970	£2124.17
Expression 3	267-980	£2665.83

Roland M-200i

32-Channel Live Digital Mixer

V-Mixer with 24 analog inputs, 12 analog outputs and stereo digital output (AES/EBU) all built-in to the main unit.

- 32-channel digital mixer. 17 motorised faders
- 24 onboard inputs and 14 outputs expandable up to 64 x 54
- iPad control for all major functions
- Wireless and wired iPad control
- Communication via Cat5/6e cable
- 4x multi-effect processors and 4x 31-band graphic EQs
- WAV recording/playback using USB memory
- Remote control via PC/Mac, and DAW



Description	Code	Price (Ex VAT)
M-200i	369-960	£1665.83

Line 6 Stagescape M20D

Mixing System



StageScape™ M20dis the world's first smart mixing system for live sound. Utilising a groundbreaking touchscreen visual mixing environment, the M20d streamlines the way you mix to get your sound dialed in quickly and help you stay in the creative zone.

Description	Code	Price (Ex VAT)
M20d	301-490	£915.83

Allen & Heath GLD-80

Digital Mixer



GLD-80 has an analogue-style channel processing control section complemented by a graphical 8.4 inch touch screen. A fully-customisable drag 'n drop layout allows quick and easy assignment of inputs and mixes to fader strips. There are 20 fader strips in 4 layers, each with motorised fader, a channel LCD display which can be named and colour-coded, plus a rotary control for direct access to gain, pan and aux/FX sends. The mixer's local I/O comprises 4 XLR mic/line inputs, 4 XLR line outs, 4 RCA inputs, 2 RCA outputs, and digital outputs in SPDIF and AES3 formats. Connects to a range of plug 'n play I/O racks to 'build' 28, 36 or 44 mic input systems. A primary AR2412 rack (24 XLR inputs, 12 XLR outs) and up to two AR84 expanders (8 XLR inputs, 4 XLR outs each) can be connected.

Description	Code	Price (Ex VAT)
GLD-80	269-510	£3665.83
AR2412	269-520	£1015.83
AR84	269-530	£474.17

Mackie DL806

8-Channel Digital Mixer

Provides the mobile freedom to wirelessly control the mix and powerful plug-in processing from anywhere in the venue.

- 8 Onyx mic preamps with high-end Cirrus Logic® converters
- 4 stereo-linkable aux sends for monitor mixes
- 4-band EQ + HPF, gate and compression on inputs
- 31-band GEQ, comp/limiter and alignment delay on outputs
- Lightning connector version available



NEW

Description	Code	Price (Ex VAT)
DL806	262-660	£549.17
DL806 Lightning	262-665	£457.50

Mackie DL32R

32-Channel Wireless Digital Mixer

Completely controlled wirelessly from Mackie's Master Fader app.

- 32-channel Touch Software-controlled with 28 Buses
- 14 Stereo-linkable Aux Sends
- 32 x 32 USB 2.0 Audio Interface
- 32 Onyx+ Microphone Preamps
- Multitrack Recording/Playback
- Onboard Digital Effects



NEW

Description	Code	Price (Ex VAT)
DL32R	262-720	£1332.50

Analogue Mixers

MIXERS

Mackie 802-VLZ4/402-VLZ4

Analogue Mixer

The 802-VLZ4 packs renowned VLZ4 quality into a tight, sleek package. Don't let the small size fool you—the 802-VLZ4 is all pro, and all VLZ4.

- 3 studio-grade preamps
- 8 line inputs
- 1 aux send per channel
- Alt ¾ stereo bus
- Low-cut filter
- Steel chassis



Description	Code	Price (Ex VAT)
802-VLZ4 Pro - 3 Mic Inputs	260-570	£165.83
402-VLZ4 Pro - 2 Mic Inputs	260-560	£85.83

Mackie 1202-VLZ4 PRO/1402-VLZ4 PRO

Analogue Mixer

These compact mixers are ideal for home and project studios, but are equally at home on the road, on the stage, or in the recording studio.

- 4 studio-grade preamps
- 12 line inputs
- 3-band active EQ
- Alt ¾ stereo bus
- Sealed rotary controls
- Steel chassis



Description	Code	Price (Ex VAT)
1202-VLZ4 - 4 Mic Inputs	260-580	£238.33
1402-VLZ4 - 6 Mic Inputs	261-050	£325.00
1402 Rack Ears	261-055	£44.34
1202 Rack Ears	900-090	£47.50
Buster Mixer Case	460-840	£129.00

Behringer Eurorack RX1602
Analogue Mixer



NEW LOWER PRICE

Professional multi-purpose 16-input ultra low-noise line Mixer.

The RX1602 can be used as an extremely flexible keyboard and multi-purpose sub-mixer, multi-track monitoring mixer, level translator, FX return sub-mixer and so on. There are 16 balanced high-headroom line inputs for individual stereo or mono use of each section. Its ultra low-noise design assures the highest possible headroom and ultra-transparent audio. Dedicated balance and level controls plus +4/-10 level selection per channel and monitor/FX send control per section with global master send control allow for flexible monitoring, recording or effects applications. An illuminated double-function mute button per section with additional clip indication provides convenience. Also features high-quality detented ALPS® rotary controls for longterm reliability, while a shielded toroidal power transformer guarantees lowest noise interference. The RX1602 is a good choice mixer when you need more inputs and crystal-clear audio performance.

Description	Code	Price (Ex VAT)
RX1602	370-650	£85.83



Mackie 1642-VLZ4 PRO

Compact Mixer

The re-engineered Mackie 1642-VLZ4 has greater headroom than the original, and enhancements to the EQs mean it has a more intuitive and musical feel.

- 10 studio-grade preamps
- 16 line inputs
- 3-band active EQ
- Balanced ¼" I/O
- Sealed rotary controls
- Steel chassis



Description	Code	Price (Ex VAT)
1642-VLZ4	261-600	£579.17
Rackit	261-615	£42.73

Mackie 2404/3204 VLZ4

Mixers

The 24/32-channel 2404/3204-VLZ4s combine low-noise and high-headroom technology with increased channel count and superior processing.

- All mic channels with 3-band mid EQ
- Channel / subgroup compression
- Connect to laptop to record or stream
- Use your favourite plug-in live



Description	Code	Price (Ex VAT)
2404 VLZ4	262-380	£941.67
3204 VLZ4	262-390	£1122.50

Mackie 1604-VLZ4 PRO

Analogue Mixer

The flagship mixer of the series, the culmination of 20 years experience in mixer design and the standard for production and broadcast facilities worldwide.

- 10 studio-grade preamps
- 16 line inputs
- Phantom power
- 6 aux sends per channel
- 4 stereo aux returns
- 3-band active EQ



Description	Code	Price (Ex VAT)
1604-VLZ4 Pro	260-630	£624.17
Rotopod	260-640	£70.48
Buster Mixer Case	460-850	£139.00

Soundcraft Folio FX16II

Analogue Mixer

Soundcraft has given the FX16 an overhaul, bringing it in line with their professional range using the latest 24bit, digital Lexicon effects processor thus creating the FX16II.

- 26 inputs with 16 mono mic channels
- 32 FX settings
- Tap Tempo
- 3-band EQ with swept mid-band
- Integral universal power supply



Description	Code	Price (Ex VAT)
Folio FX16II	260-990	£608.44

Tascam LM85T

Rackmount Line Mixer



The TASCAM LM-85T is a 1-space rackmountable line mixer for installation, studio submixing, keyboardists or anyone looking for a great-sounding mix.

- 8 pairs of balanced 1/4" TRS inputs - switchable from +4 or -10dB
- Pre or post-fader bussing is available
- A mic input is also provided for announcements or performance

Description	Code	Price (Ex VAT)
LM85T	238-140	£282.50

FREE catalogue
Are you reading someone else's catalogue? Why not call us and order your own copy...
it's free!

Analogue Mixers

MIXERS

CONTINUED

Behringer XENYX QX Series

USB Mixer Range

Can handle your live gigs and provide the state-of-the-art tools to make stunning, professional-quality recordings.

The Behringer XENYX QX series are the latest mixers offering dedicated, "wireless-ready" integration for our new ULM Series USB microphones, making them the first of their kind in the industry. Along with their built-in USB/audio interfaces, "one-knob" mono channel compressors and KLARK TEKNIK FX engines (available on select models), XENYX Q Series USB mixers come with all the recording and editing software you'll need to turn your computer into a complete, high-performance recording studio.

Mixer	Description	Code
QX2442USB	24-Input 4/2-Bus Mixer with Mic Preamps & Compressors, Multi-FX Processor, Wireless Option and USB/Audio Interface	383-440
QX2222USB	22-Input 2/2-Bus Mixer with Mic Preamps & Compressors, Multi-FX Processor, Wireless Option and USB/Audio Interface	383-850
QX1832USB	18-Input 3/2-Bus Mixer with Mic Preamps & Compressors, Multi-FX Processor, Wireless Option and USB/Audio Interface	383-860
QX1622USB	16-Input 2/2-Bus Mixer with Mic Preamps & Compressors, Multi-FX Processor, Wireless Option and USB/Audio Interface	383-870
QX1222USB	16-Input 2/2-Bus Mixer with Mic Preamps & Compressors, Multi-FX Processor, Wireless Option and USB/Audio Interface	383-880
QX1204USB	12-Input 2/2-Bus Mixer, Mic Preamps & Compressors, Multi-FX Processor, Wireless Option and USB/Audio Interface	383-450
QX1202USB	12-Input 2-Bus Mixer with Mic Preamps & Compressors, British EQs, 24-Bit Multi-FX Processor and USB/Audio Interface	383-460
QX1002USB	10-Input 2-Bus Mixer with Mic Preamps & Compressors, British EQs, 24-Bit Multi-FX Processor and USB/Audio Interface	383-470

Description	Code	Price (Ex VAT)
XENYX QX2442USB	383-440	£229.17
XENYX QX2222USB	383-850	£185.00
XENYX QX1832USB	383-860	£166.66
XENYX QX1622USB	383-870	£140.83
XENYX QX1222USB	383-880	£140.83
XENYX QX1204USB	383-450	£127.50
XENYX QX1202USB	383-460	£72.50
XENYX QX1002USB	383-470	£65.83

Behringer Ultralink MX882

Mixer



The Ultralink is an ultra-flexible 6 channel line splitter/mixer/conditioner with applications in live sound systems, studios and theatres amongst others.

- 8 in / 2 out line mixer
- 2 in / 8 out line splitter
- 6 in / 6 out level matching amp
- Bandwidth from 5Hz to 200kHz
- Usable as direct injection box
- High quality components

Description	Code	Price (Ex VAT)
Ultralink MX882	360-760	£56.25

Alesis Multimix USB 4

4 Channel Analogue Mixer

Perfect for using in basic computer-recording setups, video editing and production studios, and portable podcasting setups.

- USB stereo input and output
- Four 1/4" line-level inputs
- RCA tape in/out
- Two XLR mic inputs
- 48V phantom power
- High-impedance guitar input

Description	Code	Price (Ex VAT)
Multimix 4 USB	385-420	£49.99

DELIVERY BEFORE NOON
no problem

Behringer XENYX Q Series

USB Mixer

This great sounding compact USB/audio interface mixers provides high headroom & crystal quality recordings

- High headroom Xenyx mic preamps 130db dynamic range
- Built-in compressor & British EQ
- Stereo USB/audio interface direct to computer
- Free audio recording and podcasting software plus
- 150 instruments FX plug-ins downloadable from behringer.com



Mixer	Description	Code
Q1204USB	Premium 12-Input 2/2-Bus Mixer with XENYX Mic Preamps & Compressors, Wireless Option and USB/Audio Interface	383-890
Q1202USB	Premium 12-Input 2-Bus Mixer with XENYX Mic Preamps & Compressors, British EQs and USB/Audio Interface	383-480
Q1002USB	Premium 10-Input 2-Bus Mixer with XENYX Mic Preamps & Compressors, British EQs and USB/Audio Interface	383-490
Q802USB	Premium 8-Input 2-Bus Mixer with XENYX Mic Preamps & Compressors, British EQs and USB/Audio Interface	383-500
Q502USB	Premium 5-Input 2-Bus Mixer with XENYX Mic Preamp & Compressor, British EQ and USB/Audio Interface	383-510

Description	Code	Price (Ex VAT)
XENYX Q1204USB	383-890	£108.32
XENYX Q1202USB	383-480	£57.50
XENYX Q1002USB	383-490	£49.99
XENYX Q802USB	383-500	£45.83
XENYX Q502USB	383-510	£35.83

Behringer UFX1604

Firewire Mixer Interface

From input to output, the UFX1604 mixer is all about functionality, ease of use and ultimate versatility.

- 16-Input 4-Bus Mixer with 16x4 USB/FireWire Interface
- 8 Xenyx mic pres; 8 compressors
- 16 track USB recording and more



Behringer UFX1204

Firewire Mixer Interface

USB/FireWire interface & 16-tk USB recorder.

- 16x4 interface supports Windows XP/Vista/7 plus Mac OS X
- 8 Mic Preamps inc phantom power
- 8 One Knob Compressors
- British 4-band semi-parametric EQs
- Solo-In-Place with PFL/AFL function



Description	Code	Price (Ex VAT)
UFX1604	382-800	£407.50
UFX1204	383-840	£215.00

PDF catalogue

Want this catalogue on your phone or laptop?

The Studiospares catalogue is now available in PDF format.

visit www.studiospares.com/page/pdfcatalogue/

Behringer XENYX Series

Analogue Mixers

Popular mixer series that has connected musicians all over the world...

The UB mixer series has become one of the most popular mixer series of all time. The XENYX mixers will take you to an even higher plane. This range of premium ultra low-noise, high headroom mixers offers not only premium analogue sound, but also digital technology to bridge both worlds. The XENYX Mic Preamp matches the sound quality, transparency, headroom and even the dynamic range of boutique-style, stand-alone mic preamps.

The neo-classic "British EQ" brings back the warmth and musicality of those '60s and '70s mega-console desks that made music history. The XENYX FX mixers incorporate a new studio-grade 24-bit FX processor. Get 100 real-world and awesome effect presets at your fingertips.

These mixers come with a USB/Audio Interface for direct plug & play connectivity to your Windows® or Mac® computer. Get your audio to and from any DAW and make your XENYX mixer the perfect globetrotter in both analogue and digital worlds.

1202FX Premium 12-Input 2-Bus Mixer with XENYX Mic Preamps, British EQs and 24-Bit Multi-FX Processor. The XENYX 1202FX has 12 inputs and a FX Send control for each channel. Additionally, assignable CD/tape inputs have been incorporated for routing flexibility.

Code 380-710

1202 Premium 12-Input 2-Bus Mixer with XENYX Mic Preamps and British EQs. The XENYX 1202 has 12 inputs and a FX Send control for each channel. Additionally, assignable CD/tape inputs have been incorporated for routing flexibility.

Code 380-720

1002FX Premium 10-Input 2-Bus Mixer with XENYX Mic Preamps, British EQs and 24-Bit Multi-FX Processor. The XENYX 1002FX has 10 inputs and a FX Send control for each channel. Additionally, assignable CD/tape inputs have been incorporated for routing flexibility.

Code 380-730

1002 Premium 10-Input 2-Bus Mixer with XENYX Mic Preamps and British EQs. The XENYX 1002 has 10 inputs and a FX Send control for each channel. Additionally, assignable CD/tape inputs have been incorporated for routing flexibility.

Code 380-740

1002B Premium 10-Input 2-Bus Mixer with XENYX Preamps, British EQs and Optional Battery Operation. 4 balanced, high-headroom stereo inputs with 3 additional mic inputs. 3-band British EQ, plus an FX and monitor send for each channel. Switchable phantom power for condenser

microphones.

Code 382-220

802 Premium 8-Input 2-Bus Mixer with XENYX Mic Preamps and British EQs. The XENYX 802 has 8 inputs and a FX Send control for each channel. Additionally, assignable CD/tape inputs have been incorporated for routing flexibility.

Code 380-750

502 Premium 5-Input 2-Bus Mixer with XENYX Mic Preamp and British EQ. The XENYX 502 has 5 inputs and main mix, stereo CD/tape plus separate headphone outputs. Additionally, assignable CD/tape inputs have been incorporated for routing flexibility.

Code 380-760

1204USB Premium 4 phantom-powered XENYX Mic Preamps & 4 studio-grade compressors. The XENYX 1204USB has 12 ins 2/2 outs, Neo-classic 'British' 3-band EQs, New studio-grade FX processor with 16 editable presets, Rack mount brackets included.

Code 382-640

302USB Premium 5-Input Mixer with XENYX Mic Preamp and USB/Audio Interface. Powered through USB or external power adaptor (included). Free audio recording, editing and podcasting software, Neo-classic "British" 2-band graphic EQ, 2-Track input assignable to Headphone or Main Mix output.

Code 382-810

Description	Code	Price (Ex VAT)
1202FX	380-710	£62.50
1202	380-720	£52.50
1002FX	380-730	£56.50
1002	380-740	£45.00
1002B	382-220	£66.66
802	380-750	£36.00
502	380-760	£26.25
1204USB	382-640	£89.00
302USB	382-810	£29.92



behringer



XENYX 1202FX



XENYX 1202



XENYX 1002B



XENYX 802



XENYX 1002FX

Analogue Mixers

MIXERS

CONTINUED

Behringer Eurodesk SX3282/SX4882

Analogue Mixers

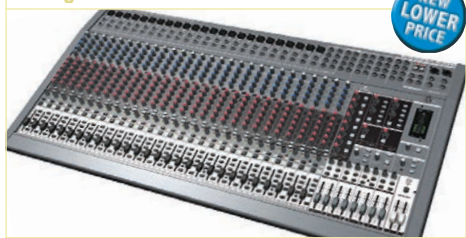

NEW LOWER PRICE

The Behringer SX3282/SX4882 32-Input/48-Input, 8-Bus mixer with XENYX Mic preamps and British EQs is an ultra low noise, high headroom analogue mixer, for studio, live, front of house, monitor, corporate and touring audio applications. The Behringer SX3282 features 24 state of the art XENYX mic preamps with switchable +48V phantom power, plus 4 stereo line inputs. It also has Neo-classic "British" 4-band EQ stereo channels and 3-band EQ with semiparametric mid band mono channels for a warm and musical sound. It also features balanced inputs and main outputs for highest signal integrity. Its high quality components and exceptionally rugged construction ensure long life.

Description	Code	Price (Ex VAT)
SX3282 - 32 Inputs	382-200	£415.83
SX4882 - 48 Inputs	382-210	£582.50

Alesis MM4USB FX

4 Channel Mixer

Utility mixer with effects and USB audio interface.

- 4-channel mixer with stereo (2) 1/4" inputs and stereo (2) 1/4" outputs
- 16-bit, 44.1/48 kHz signal stereo in / stereo out via USB
- 2x XLR inputs with gain trim, switchable high-pass filters, and 48V phantom power
- 4x 1/4" line-level inputs for instruments and high-impedance guitar input
- 15 DSP effects and Dual-band EQ



NEW

Description	Code	Price (Ex VAT)
MM4USB FX 4 Channel	395-170	£66.66

Alesis MM10 Wireless

Wireless Mixer

A 3U rack mounted mixer with 10 inputs.

- Chans 1-4 XLR/Jack inputs for mics or DI boxes
- Phantom powering
- Chans 5-8 are 2 stereo pairs for keyboards, drum machines, external mixers, FX etc
- Chans 9-10 Bluetooth inputs via an aerial



Description	Code	Price (Ex VAT)
MM10 Wireless	395-030	£191.66

Art MX622

Rackmount Mixer



A versatile mixer combining three balanced mic or line level inputs with three stereo line inputs into a single stereo line level mix. Essential features include external effects loop (mono send with stereo return), and independent stereo record outputs.

- Level control and clip indicators
- Selectable 15-volt phantom power for mic channels
- Balanced TRS 1/4-inch main output jacks with master level control
- Versatile two-band master EQ

Art MX822

Rackmount Mixer



A versatile eight input mixer for studio, live sound or installation applications.

- Eight stereo/mono input channels with individual level, pan and effects send controls
- External effects loop with independent send and return controls
- Front panel 1/4-inch stereo (TRS) headphone jack with amplifier and independent level control for output monitoring
- Balanced left and right XLR main outputs
- Rugged 1U rack mount steel case

Description	Code	Price (Ex VAT)
MX622 6-Channel	325-720	£111.50
MX822 8-Channel	326-030	£157.50

Behringer XENYX X USB Series

USB Mixer Range

Probably the most popular range of mixers currently on sale worldwide!

The Xenyx X USB series combine a great set of features, solid build quality, and fantastic value for money. Different sizes and formats to suit most needs.

Mixer	Description	Code
X1204USB	12-Input, 2/2-Bus Mixer with 4 Mic Preamps and Compressors	382-650
X1222USB	16-Input, 2/2-Bus Mixer with 4 Mic Preamps and Compressors	382-660
X1622USB	16-Input, 2/2-Bus Mixer with 4 Mic Preamps and Compressors	382-670
X1832USB	18-Input, 3/2-Bus Mixer with 6 Mic Preamps and 6 Compressors	382-680
X2222USB	22-Input, 2/2-Bus Mixer with 8 Mic Preamps and 8 Compressors	382-690
X2442USB	24-Input, 4/2-Bus Mixer with 10 Mic Preamps and 8 Compressors	382-700

Description	Code	Price (Ex VAT)
XENYX X1204USB	382-650	£102.50
XENYX X1222USB	382-660	£127.50
XENYX X1622USB	382-670	£127.50
XENYX X1832USB	382-680	£157.50
XENYX X2222USB	382-690	£165.83
XENYX X2442USB	382-700	£240.83



NEW LOWER PRICE

Low noise, high headroom analogue mixers with state-of-the-art phantom-powered XENYX mic preamps and compressors, "British" 3-band EQs, studio-grade 24-bit multi-FX processor, and built-in stereo USB Audio Interface, with energyXT2.5 Compact software included.

Allen & Heath XB-14²/XB-10

Broadcast Mixing Desk

Designed for a broad range of radio broadcast applications.

XB-14² offers a host of specialised broadcast features including telephone communication (telco) channels, mic channel ON switch sensing, stereo channel start/cue outputs for playback device control, automatic muting of speaker outputs and much more. With a wealth of routing options, dual stereo channels for up to 7 stereo sources, and the addition of a dedicated Audition bus, enhanced microphone preamps and stereo channel gain range, XB-14² satisfies the demands of small radio and internet broadcasters as well as larger studios with multiple rooms. The main difference between the mixers is there are more channels running proper fader strips on the XB14² while the XB10 features compact compressors on each mic channel plus a variable limiter on the main output not available on the XB14².



Description	Code	Price (Ex VAT)
XB14 ²	269-140	£707.50
XB10	269-500	£415.83

ALLEN & HEATH

1000s
of products
Available from stock!

Soundcraft LX7 II

Analogue Mixers

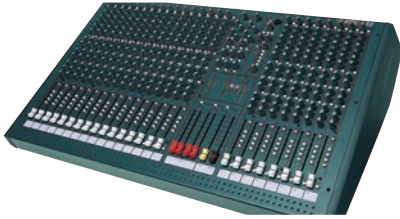

The latest multi purpose Mixer to be launched by Soundcraft. The LX7 II is aimed at both recording and live setups, featuring stereo mix outputs, four sub groups or 16 direct outs for stereo, 4 track or multitrack recording. Anyone involved in live work will appreciate the number of available inputs, 6 auxiliaries, 7 buss configuration and rugged construction including metal bodied connectors. The 7 buss output section comprises 4 sub groups, left/right and mono outputs. The power supply is built in.

Description	Code	Price (Ex VAT)
LX7 II 16 Channels 24 Inputs	260-600	£707.50
LX7 II 24 Channels 32 Inputs	260-490	£990.83
LX7 II 32 Channels 40 Inputs	267-040	£1040.83

Soundcraft GB2R 12.2

Analogue Mixer

This 19" rack-mountable mixer is designed specifically for smaller installations in churches and performance venues as well as broadcast.

- 12 mono inputs and 2 stereo inputs
- +48V phantom power
- 100Hz Hi-pass filter
- Direct outs on every channel
- 100mm faders



Soundcraft GB2R 16

Analogue Mixer

- As the GBR 12.2, but with 16 Mono inputs, Stereo mix output and 6 auxiliary sends.

Description	Code	Price (Ex VAT)
GB2R 12.2	267-800	£875.00
GB2R 16	267-790	£895.00

Audient ASP4816

48-Input Inline Console

The perfect centre piece for production studios and educational facilities.

- In-line architecture - twin inputs on each channel
- Features Audient's renowned Class A preamp and 4 band EQ
- 40 faders
- 48 inputs at mix
- 16 Audient Class-A mic pres
- 16 channels of EQ
- 16 record buses
- 6 auxes, 2 cue sends
- Stereo bus compressor
- Comprehensive monitor section



Description	Code	Price (Ex VAT)
ASP4816	201-080	£8950.00

Soundcraft EPM Series
Analogue Mixers

The emphasis with the Soundcraft EPM is very firmly on build quality and audio performance.



With an easy to understand control surface uncluttered by unnecessary facilities, Soundcraft have brought new technologies and ideas to this very cost-effective range. The highly transparent GB30 Mic amp is the same one used in the LX7ii and GB range Soundcraft consoles. Surface mount technology is used throughout, using close-tolerance components for high accuracy and repeatable settings for EQ and gain controls. The EPM has 60mm high quality faders, parallel monitor and headphone outputs and a unique LED metering system. Frame sizes available 6+2, 8+2 and 12+2.

Description	Code	Price (Ex VAT)
EPM6	267-660	£131.91
EPM8	267-670	£149.17
EPM12	267-680	£202.50



Allen & Heath GL2400

Mixer

Designed for professional applications, whether mixing FOH or monitors, recording live or in the studio, or installed in a house of worship.

- LR and M main outputs
- 4 Audio groups with pan control
- 6 Auxiliary sends with per-channel pre/post fader switching
- 7x4 Matrix for unique flexibility



Description	Code	Price (Ex VAT)
GL2400 16 Channel	269-200	£1030.00
GL2400 24 Channel	269-210	£1299.17
GL2400 32 Channel	269-220	£1776.67
GL2400 40 Channel	269-230	£1995.83
RPS11 Power Supply	269-240	£575.02

Behringer Eurodesk SX Series

Analogue Mixers

Unite studio perfection with live performance with this ultra-low noise design studio/live mixer.

- Premium ultra-low noise, high-headroom analogue mixer
- 16 state-of-the-art mic preamps
- Neo-classic "British" 3-band EQ for warm and musical sound
- 2 independent studio-grade 24-bit FX processors with 99 presets
- 9-band stereo graphic EQ



Mixer	Description	Code
SX2442FX	24 Channels, 24 Inputs	381-760
SX3242FX	32 Channels, 32 Inputs	381-770

Description	Code	Price (Ex VAT)
SX2442FX	381-760	£282.50
SX3242FX	381-770	£329.17

Soundcraft Spirit M Series
Analogue Mixers

Mixer range equally suited to recording and live sound applications.

The Spirit M4, M8 and M12 offer 4, 8 and 12 mono inputs respectively, and all feature four stereo inputs, four stereo returns, 100mm long throw faders throughout and a SPDIF stereo digital output. All channels have peak and signal LEDs, complemented by a high-resolution stereo output meter. This series includes Classic British 3-band EQ with swept mid-signal routing and includes, Insert point on every mono channel for external signal processing, 4 Auxiliary Sends - 2 pre-fade, 2 post-fade, 4 dedicated level-controlled Stereo returns with peak LEDs and master level control, Pre-/Post-fade switchable direct output on every mono input channel, PFL on each channel for signal monitoring pre-fader and AFL monitoring of each Aux. There is also 2-track playback inputs with level control, PFL and a mix replacement function. Metering is via a 12 segment Bar Graph plus Signal detect and peak LEDs on all input channels. Input channels also incorporate 48volt phantom powering and a 100Hz high pass filter. The mechanics are based on a rugged steel chassis with integral rackmount capability. Dimensions. Height 119mm. Depth 523mm. Width 4ch 397mm. Width 8/12 ch 506mm with sides (483mm Rackmounted).



Description	Code	Price (Ex VAT)
M4 - 4 Mono Inputs	267-100	£307.50
M8 - 8 Mono Inputs	267-110	£257.50
M12 - 12 Mono Inputs	267-120	£332.50



VISIT
our trade counter

You'll get friendly advice and immediate access to 8000+ product lines!

Analogue Mixers

MIXERS

CONTINUED

Yamaha MG Series

Analogue Mixer Range

Gives you the tools you need to elevate your mixes to a higher plane.



Mixer	Description	Code
MG06	6-Channel; Max. 2 Mic / 6 Line Inputs	274-680
MG10	10-Channel; Max. 4 Mic / 10 Line Inputs	274-690
MG12	12-Channel; Max. 6 Mic / 12 Line Inputs	274-700
MG16	16-Channel; Max. 10 Mic / 16 Line Inputs	274-710
MG20	20-Channel; Max. 16 Mic / 20 Line Inputs	274-720
MG06X	6-Channel; Max. 2 Mic / 6 Line Inputs / Built-in SPX Digital Effects	274-730
MG10XU	10-Channel; Max. 4 Mic / 10 Line Inputs / Built-in SPX Digital Effects	274-740
MG12XU	12-Channel; Max. 6 Mic / 12 Line Inputs / Built-in SPX Digital Effects	274-750
MG16XU	16-Channel; Max. 10 Mic / 16 Line Inputs / Built-in SPX Digital Effects	274-760
MG20XU	20-Channel; Max. 16 Mic / 20 Line Inputs / Built-in SPX Digital Effects	274-770

Description	Code	Price (Ex VAT)
MG06	274-680	£74.17
MG10	274-690	£99.99
MG12	274-700	£182.50
MG16	274-710	£269.00
MG20	274-720	£405.00
MG06X	274-730	£87.50
MG10XU	274-740	£135.00
MG12XU	274-750	£215.83
MG16XU	274-760	£307.50
MG20XU	274-770	£445.83

The new MG series embodies Yamaha's pursuit of design excellence, and uses many of the same technologies developed for their high-end professional consoles. With studio quality preamps, powerful digital processing and rugged, reliable construction, the MGs are a perfect mix of great sound quality, reliability and value.

For a more precise control and enhancement of your sound, X and XU models of the MG Series come equipped with a suite of Yamaha's renowned SPX effects. Featuring high-resolution Chorus, Flanger, Distortions, Reverb and Delay, all with editable parameters, these are the same multieffects processors used on Yamaha's high-end mixing consoles.



Allen & Heath ZED 18

Analogue Mixer

The multi-purpose USB mixer for live sound and recording.

- Neutrik mic XLR & 1/4 inch jacks
- 3 band EQ with MusiQ
- 4 auxes & illuminated mute
- ALPS 100mm faders
- 10 wide gain mic line inputs and 4 stereo channels with 2-band EQs
- Configurable USB audio in/out
- Bundled with Cakewalk SONAR X1 LE



Description	Code	Price (Ex VAT)
ZED 18	269-400	£365.83

Allen & Heath ZED 16FX

Analogue Mixer

This mixer offers musicians, venues and hire companies access to 10 full mono channels, 3 stereo channels and a high quality FX unit in a compact, rack mountable format.

- Configurable USB audio in/out
- 3 stereo channels with 2-band EQ
- 16 internal time-delay effects
- Neutrik mic XLRs
- Bundled with Cakewalk SONAR X1 LE



Description	Code	Price (Ex VAT)
ZED 16FX	269-390	£428.33

Allen & Heath ZED R16

Live Mixer

The ZED-R16 is an exceptional recording mixer with 18 FireWire I/O which can also be used as a versatile live front of house mixer.

- 16 ADAT I/O
- Internal condenser talkback mic
- 4 aux buses
- 60mm faders
- Midi mappable controllers
- Sonar LE included



Description	Code	Price (Ex VAT)
ZED R16	269-130	£1313.33

Yamaha MGP Series

Mixing Consoles

Offers premium features not normally found on mixers at this price.

- 16 microphone inputs
- Discrete Class A D-PRE Mic Preamps
- Musical X-pressive EQ
- Dual Digital Effects Processors: REV -X and Classic SPX
- Stereo Hybrid Channels DSP Effects (Leveler, Stereo Imager, Priority Ducker)
- Digital Connectivity for iPod/iPhone
- USB Devices recorder (16-bit WAV, MP3) and playback
- Master compressor (3-band) assigned to stereo bus



Description	Code	Price (Ex VAT)
MGP12X 12-Channel	274-780	£429.17
MGP16X 16-Channel	274-790	£540.83
MGP24X 24 Channel	274-590	£732.50
MGP32X 32 Channel	274-600	£865.83

DELIVERY BEFORE NOON
no problem



Behringer Eurorack RX1202FX

12-Channel Rack-Mount Mixer

Multi-track monitoring or as a line mixer in fixed audio/video installations.

A versatile and multi-purpose 12-channel rackmount mixer that has been designed as submixer for your keyboard and drum setup, multi-track monitoring or as a line mixer in fixed audio/video installations. It contains 8 Behringer IMP Preamps with ultra-low noise and also features a 24-bit digital stereo FX processor with 100 presets, switchable +48 V phantom power for condenser microphones and offers 2-band EQing with Clip LED for each channel. The mixer is 3U and has a depth of 155mm.

Description	Code	Price (Ex VAT)
RX1202FX	381-090	£124.17



VISIT
our trade counter

You'll get friendly advice and immediate access to 8000+ product lines!

1000s
of products
Available from stock!

Allen & Heath ZED Series

Analogue Mixers

ZED highly configurable, professional build mixer suitable for studio & live uses. It features control room speaker and alternate speaker outputs & two separate artist monitor feeds. Also featured is an internal soundcard that has FireWire inputs and outputs plus ADAT I/O. Each channel has its own independent soundcard channel so instruments can be recorded simultaneously and into the sequencer separately. The ZED series allows mixing down in analogue, then recording back into the computer in digital. Comes with SONAR LE software.

Allen & Heath ZED12FX

Live Mixer

- 12 channels
- 2 pre and 2 post aux sends
- Phantom power
- 16 unique effects
- USB stereo audio in/out
- Cakewalk Sonar Le included



Allen & Heath ZED22FX

Live Mixer

- 22 channels
- 16 mono inputs
- 3 stereo inputs
- 16 unique effects
- Phantom power
- Cakewalk Sonar Le included



Allen & Heath ZED14

Stereo Mixer

- 6 mono channels
- 4 stereo channels
- USB audio input
- Stereo return
- 2-track return
- 12-bar LR meters



Allen & Heath ZED24

Stereo Mixer

- As the ZED14 but with 24 channels

Allen & Heath ZED420

Group Mixer

- 16 mono inputs and
- 2 dual stereo channels
- 4-band EQ
- 2 dual stereo inputs
- 6 aux sends
- Phantom power



Allen & Heath ZED428

Group Mixer

- 24 mono inputs
- 2 dual stereo channels
- 4-band EQ
- Direct out on mono channels
- 6 aux sends
- Phantom power

Allen & Heath ZED436

Group Mixer

- 32 mono inputs
- 2 dual stereo channels
- USB stereo audio in/out
- Phantom power
- 6 aux sends
- 4-band EQ



Description	Code	Price (Ex VAT)
ZED12FX	269-000	£340.83
ZED22FX	269-010	£504.17
ZED14	269-020	£290.00
ZED24	269-030	£435.00
ZED14 Rack Kit	269-040	£37.50
ZED420	269-050	£746.67
ZED428	269-060	£967.50
ZED436	269-070	£1175.00

Powered Mixers

MIXERS

Behringer Europower PMP Series
Powered Mixer

Popular new and innovative powered mixer series...

The new and innovative Behringer PMP Powered Mixers (2 x 800-Watt stereo, 1600-Watt bridged mode) produce even more power than their predecessors while maintaining a famously low weight and high efficiency. These mixers employ Class-D technology including a new switch-mode power supply, significantly reducing weight and heat. The 20-channel PMP6000 features 12 built-in XENYX preamps, the 16-channel PMP4000 features 8 built-in XENYX mic preamps, and the 10-Channel PMP1680S features 8 high-quality built-in mic preamps.



Description	Code	Price (Ex VAT)
PMP1680S	382-610	£249.17
PMP4000	382-620	£275.00
PMP6000	382-630	£342.50

All three models feature 24-bit FX processors and FBQ Feedback Detection.



Behringer Europower PMP2000

Powered Mixer

Ideal if you need superior stereo sound for small club gigs, churches or speeches, but have to keep the outboard gear to a minimum,



- 14 channel mixer section
- 2 x 350W
- 24-bit stereo FX processor
- 9 high-quality mic preamps
- phantom power
- Dual 9-band graphic EQ



Description	Code	Price (Ex VAT)
Europower PMP2000	381-280	£199.17

Behringer Europower PMP1000

Powered Mixer

If you need a superior stereo sound but have to keep the outboard gear to a minimum, the PMP1000 can deliver.



- 12 channel mixer section
- 2 x 250W
- 24-bit stereo FX processor
- 6 high-quality mic preamps
- Phantom power
- 3-band EQ



Description	Code	Price (Ex VAT)
Europower PMP1000	381-270	£207.50

Yamaha EMX Series

200 - 500 Watt Powered Mixers



Stereo channels 9/10 and 11/12 include phono jacks for connection of playback devices, to which the 3-band channel equalisers can be applied. There are also two 7-band graphic equalisers. The cabinets are made from a lightweight-but-rugged material, while a switching power supply delivers all the clean power the system needs. Each mixer features a forced-air cooling system and a feedback channel locating system. The mixers can be rack mounted using the optional RK512 rack-mount kit. The EMX3125C and EMX5125C feature one knob compressors on all four mono mic/line channels and also include 16 Yamaha SPX effects.

Description	Code	Price (Ex VAT)
EMX2125 12 Channels 200W	274-000	£254.17
EMX3125 12 Channels 300W	274-010	£290.00
EMX5125 12 Channels 500W	274-020	£363.33
RK512 Rack Kit	274-030	£37.49

FREE
catalogue
Are you reading someone else's catalogue?
Why not call us and order your own copy...
it's free!

PRICE
match
Studiospares will BEAT any genuine price from any UK competitor on any item or order.
details on page 318

MIXERS

Zone Mixers

Behringer Ultrazone ZMX8210

Zone Mixer



A professional 8-channel audio mixer designed specifically for fixed installations that can distribute music programming and announcements to up to three zones.

- 6 low noise mic/line inputs
- 2 selectable stereo inputs
- 3 assignable outputs
- 4-band master EQ
- Global mic low-cut filter
- Channel muting system

Description	Code	Price (Ex VAT)
Ultrazone ZMX8210	381-750	£99.17

PORTABLE PA

Portable PA

Fender Passport Conference

Portable PA System

Perfect for the layperson who needs quality with simple functionality.

- 175 watts of power
- Included microphone kit contains mic, cable, clip in zipper pouch
- Five-channel mixer
- Inputs 3x XLR and 5x 1/4" mic/line and 1x Stereo Minijack
- Volume and tone controls
- Stereo output for headphone monitoring and stereo mixes



Fender Passport Mini

Portable PA System

Goes anywhere thanks to its dual AC- or Battery-powered capabilities.

- Output Power 7 Watts
- Controls: Vocal Channel Volume, Tone, Reverb Level
- Controls Instrument Channel: Volume, Preset, Effects, Tap, Tempo Button
- Inputs: 2x Jacks one with 20dB Pad Switch
- Auxilliary Input Stereo Minijack
- Headphone Output Stereo Minijack



Fender Expo

Portable PA System

Portable full-range sound for audiences up to 300.

- Elegant small-footprint design
- 1" Neodymium Horn-Loaded Tweeter
- Eight Custom-Designed 3" Neodymium Midrange Drivers
- Multi-Pin Connection System Steel Stability Bars
- Two 6.5" Sub Speakers
- Power/Signal/Limit/Protect Indicator LEDs
- Stereo XLR Line Outputs



Fender Passport Event

Portable PA System

A self-contained seven channel portable audio system that includes everything you need.

- 375 Watts output
- Channel Controls Volume, Treble, bass, Reverb, 20dB pad
- Hi Z Instrument/Line Switch
- Bluetooth Pair Switch
- Inputs, 4x XLR Mic/Line, 1x Jack Instrument/Line, 2x Stereo Mic/Line
- 1x Stereo Bluetooth
- Speakers 2x 8" and 2x 1.2" Horn Loaded Tweeters



Fender Passport Venue

Portable PA System

Lets you record WAV audio files using a USB flash drive and play WAV and MP3 files.

- 600 watts output
- Input Channels: 10x (4x Mic/Line, 2x Line/Hi-Z, 2x Stereo plus USB
- Channel Controls: Volume, Treble, Bass, Reverb and Phantom Power
- 20dB Pad (chans 1-4)
- Controls for Reverb: Time and Tone, Master Volume
- USB (Record, Play/Pause, Previous/Next Track
- Outputs: 3x Line Inc Headphone, 1x Sub Output



Fender Passport Studio

Portable PA System

The world's first truly portable world-class studio monitoring system

Passport Studio houses a world-renowned Focal® driver set in a portable, protective and meticulously tuned enclosure, complemented by convenient front-panel controls and connectivity. Travel from tracking to mixing sessions down the street or across the country, with complete confidence that your monitors will arrive unharmed. 120V, Black, 150W of output power.

Interlocking cabinets with handle grip for driver protection and extreme portability, front-ported enclosures, universal voltage power supply (supports 110V-240V operation), built-in cable storage, and magnetic rear doors.



Description	Code	Price (Ex VAT)
Passport Conference	211-000	£235.00
Passport Event	211-010	£474.17
Passport Venue	211-020	£554.17
PS-512 Powered Sub	211-030	£257.50

Description	Code	Price (Ex VAT)
Passport Studio	211-050	£310.83

DELIVERY BEFORE NOON
no problem

SATURDAY DELIVERY
no problem

Studiospares Trojan iPA800

Portable PA System

A substantial and versatile Portable PA system with an internal battery pack for outdoor operation. Innumerable uses throughout industry and education.

The iPA800 provides three Inputs. Chan1. Balanced Microphone input, Chan 2. Unbalanced Mic/Line input, Chan 3. CD L&R, Tape or iPod. There are equalisation controls for high, mid and low EQ and a master volume control. A rear panel jack socket provides an output for a mixer or PA system. An iPod plugs into an appropriate socket on the horizontal top panel. Under an adjacent lid is a receptacle for a microphone (included) plus space for it's lead. The iPA800 includes an 8" bass driver and tweeter so will never lack punch, clarity or sound "muddy" The 15 watts (22 watts peak) output is sufficient to fill a modest sized room. A 35mm top hat in the base allows for it to be mounted on a speaker stand. The internal batteries are automatically recharged from the mains whilst the iPOD can be charged at the flick of a switch. The unit is substantial and includes two rollers for easy transportation. Additionally, two substantial handles make lifting in and out of cars much easier. This product will give a good account of itself and will always be a pleasure to use.



Description	Code	Price (Ex VAT)
iPA800	250-210	£115.83
iPA800 + Stand + Bag	250-211	£132.50
iPA800 + Microphone Stand + Bag	250-212	£124.17
iPA800 + Stand + Microphone Stand + Bag	250-213	£140.83



Studiospares Trojan 910

PA Package

Perfect for smaller theatres, halls or other spaces.

The Studiospares Trojan 910 PA Package brings together top-selling products from our ultra-reliable Trojan and Fortissimo ranges to offer you what we believe is one of the best budget PA systems you will find anywhere! As a guide, this system will typically give great sound levels for audiences up to around 200 people. And the sound reinforcement quality is excellent for speech as well as for music.

Includes:

- Studiospares Trojan 900 Power Amp
- Studiospares Fortissimo 10P Passive Speakers x2
- Studiospares PA Speaker Stands x2
- Studiospares Speaker Stand Bag x2
- Studiospares PA Speaker Leads x2



Description	Code	Price (Ex VAT)
Trojan 910	250-200	£339.00



Studiospares iPA10

Portable PA System

A Roll Around PA system with a multitude of application and multiple facilities.

- 10" bass driver for increased output
- Soft domed tweeter and a more powerful amplifier
- Output power 30 watts RMS (60 watts peak music power)
- Dock for iPad etc. 35mm top hat socket on underside
- Mic input on Combi XLR/Jack
- Aux/CD/Tape input via phono connectors
- EQ: Bass, Mid and Treble
- Comprehensive set of controls for MP3 playback
- Inputs for MP3, USB, Bluetooth plus conventional microphones and line level devices.
- USB charging point for iPad.



NEW

Description	Code	Price (Ex VAT)
iPA10	250-250	£149.17

Yamaha Stagepas 400i/600i

Portable PA System

A complete, extremely portable sound solution.

- Can be set up quickly and easily in a variety of configurations and environments
- Two sleek, lightweight speakers
- Detachable powered mixer
- A pair of speaker cables
- Power output - 400W for the 400i and 680W for the 600i
- Frequency Range 55Hz - 20kHz
- Mixer - 8 channels for the 400i and 10 channels for the 600i



NEW LOWER PRICE

Description	Code	Price (Ex VAT)
400i	274-650	£397.50
600i	274-660	£595.00
600i Trolley	274-665	£62.50

Samson XP25i

Portable PA with Dock

The handheld PA system for on-the-go audio making PA more mobile than ever before.

- Compact, lightweight, design with carry handle and strap
- 5-inch full-range loudspeaker with 25 watts of power
- Push-to-talk microphone included
- Built-in iPod dock with level control
- Integrated mic stand mount and rechargeable battery included



Description	Code	Price (Ex VAT)
XP25i	388-790	£141.66

Samson XP510i

Portable PA with Dock

An all-in-one portable PA offering impressive power and convenience adopted from the XP308i.

- Dual 2-way speaker enclosures with powered mixer built-in 500W Class D amp
- 10-channel mixer with built-in iPod dock, four mic/line inputs, 3 stereo inputs and phantom power
- Custom 10-inch woofers
- Ten studio-quality 24-bit digital effects



Description	Code	Price (Ex VAT)
XP510i	388-780	£499.17

PORTABLE PA

Portable PA

CONTINUED

Behringer Europort EPA Series

Portable PA System

Set up in less than five minutes and deliver high fidelity performance.

These portable PA systems are super-light weight and feature a studio-grade 24-bit stereo FX processor with 100 presets. There is an FBQ feedback detection system which instantly reveals critical frequencies for easy feedback removal. Both models feature an extremely musical 2-band EQ, switchable pad and clip LEDs on all mono channels. There is a voice canceller function and they are supplied with a Behringer XM1800S microphone, mic clip and 20' cables.

Behringer Europort EPA300

Portable PA System

- 300 watts, 6 channels, 8" woofers
- Mixer section features 2 mono/stereo channels plus CD inputs
- 2 mic preamps
- Stereo 5-band graphic EQ



Behringer Europort EPA900

Portable PA System

- 900 watts, 8 channels, 10" woofers
- Mixer section features 4 mono/2 stereo channels plus CD inputs
- 4 mic preamps
- Stereo 7-band graphic EQ



Description	Code	Price (Ex VAT)
EPA300	382-590	£270.83
EPA900	382-600	£425.00



Behringer Europa EPA40

Portable PA System

40-Watt handheld PA system with rechargeable battery and microphone.

- Projects to a crowd of up to 100
- Ideal for business meetings, tour guides, classrooms
- Ultra-compact and easy to operate
- Mic and Aux inputs
- 5" full-range loudspeaker



Description	Code	Price (Ex VAT)
EPA40	381-600	£68.00

Behringer Europort EPA150

Portable PA System

Ultra-compact 2x 75W, 5-channel portable PA system in a briefcase format.

- FBQ feedback detection system
- Power, performance and light weight
- Studio-grade 24-bit stereo FX processor with 100 awesome presets including reverb, chorus, flange and various multi-effects



Description	Code	Price (Ex VAT)
EPA150	383-220	£185.00

Alesis Transactive Wireless

Portable Powered Bluetooth Speaker System

The all-in-one TransActive Wireless is a complete, active PA system designed for on-the-go use.

Pull up the telescoping handle, tilt the amp onto the recessed wheels, and take your TransActive Wireless with you wherever you go. Once you're there, simple single-button pairing allows you to instantly stream audio from any Bluetooth device. In addition to Bluetooth streaming, the TransActive Wireless offers a variety of inputs to accommodate almost any source—microphone, guitar, keyboard, computer, drum machine, CD or MP3 player—whatever you need. Use the TransActive Wireless to perform, to play music, or to make your voice heard. TransActive Wireless is equipped with a built-in amplifier offering plenty of power, low distortion and high efficiency. The large driver delivers a solid low end and powerful, crisp highs. The convenient built-in rechargeable battery delivers up to 50 hours of cordless amplification.

Description	Code	Price (Ex VAT)
Transactive Wireless	385-970	£149.99

ALESIS



QTX PPA74

Portable Karaoke System

This fantastic value all-in-one Karaoke/DVD system is packed with great features.

The PPA74 has a DVD player, digital audio player, card reader function (SD/MMC) and USB input. The unit also has 5.1 surround sound outputs for home cinema use, this product is so versatile its uses are endless and to top it all, it can run with its own rechargeable batteries. Includes Full function remote control (batteries supplied), 8" bass driver and 1" tweeter, Integral DVD and audio media players, USB and card reader (SD/MMC) function, 5.1 surround sound outputs. Supplied with 2 handheld VHF wireless microphones and 2 wired microphones with 4.5m XLR-jack leads, Dual rechargeable batteries (12V, 5Ah), 5 hours battery life (DVD player) and 10 hours (Voice amplification). Trolley with telescopic handle supplied as an accessory.



Description	Code	Price (Ex VAT)
PPA74	248-800	£289.00

JBL EON 615

15" Two-Way Multipurpose PA System

NEW



More than just another great JBL sound system, the new EON615 is a true step forward in technology developed specifically to deliver the best sound possible regardless of its application. Completely rethinking how truly good an affordable self-contained, portable PA system can be, JBL engineers purposely designed and built the EON615 from the ground up featuring JBL's advanced waveguide technology, JBL designed and manufactured transducers, and convenient, wireless remote control of its onboard DSP EQ parameters via Bluetooth. This total redesign of the EON platform leverages the latest technologies in cabinet materials, acoustic science, transducer design and user friendliness that delivers the extraordinary quality of a high-end studio monitor in a fully professional, highly flexible, easy to use, portable system for today's working musicians and sound providers.

Description	Code	Price (Ex VAT)
EON615 x 1	445-340	£415.83

Behringer Ultratone K450FX

Portable Sound System

Super-compact 45W sound system ideal for PA systems, keyboards, voice, or drum/backing machines.

- 24-bit digital FX with 100 hot presets
- FBQ Feedback Detection System
- Full 3-channel operation with separate volume controls
- XLR mic input for connecting dynamic microphones
- CD input plus a headphone output



Description	Code	Price (Ex VAT)
K450FX	380-460	£115.83

Studiospares Silver PA Package

A popular and cost effective combination suitable for venues, schools, large pubs, small theatres and private functions up to 500 people.

- 2x 15 inch Active Fortissimo** Code 248-260
- 1x Soundcraft Spirit M12 with 12 mic inputs** Code 267-120
- 2x Leads XLR male - XLR Female 5m** Code 588-270
- 2x Speaker Stands** Code 448-300
- 1x Bag for stands** Code 458-920



IF BOUGHT SEPARATELY: £792+VAT	OUR PRICE £659+VAT	SAVE £160 (INC VAT)
--	------------------------------	----------------------------------

Description	Code	Price (Ex VAT)
Silver	250-120	£659.00



Studiospares Fortissimo 10 PA Package

Excellent entry-level kit for small venues and private functions up to 200 people.

- 2x 10 inch Active Fortissimo** Code 248-240
- 1x Behringer Xenyx 1002FX Mixer with 2 mic inputs** Code 380-730
- 2x Leads XLR male - St Jack** Code 589-540
- 2x Speaker Stands** Code 448-300
- 1x Bag for stands** Code 458-920



If bought separately: £457+VAT	OUR PRICE £369+VAT	SAVE £105 (INC VAT)
--	------------------------------	----------------------------------

Description	Code	Price (Ex VAT)
Fortissimo 10	250-100	£369.00

Studiospares Platinum PA Package

Superb combination of top quality equipment ideal for larger venues, auditoriums, halls and clubs.

- 2x Dual 15" Passive Auditorium** Code 248-860
- 1x Crown XT14002** Code 243-160
- 1x Spirit LX7ii 16 Channels** Code 260-600
- 2x 5m Speakon Cables** Code 588-890
- 2x 5m XLR Leads** Code 588-270



If bought separately: £2241+VAT	OUR PRICE £2075+VAT	SAVE £199 (INC VAT)
---	-------------------------------	----------------------------------

Description	Code	Price (Ex VAT)
Platinum	250-140	£2075.00

Studiospares Fortissimo 12 PA Package

Highly specified system featuring the Fortissimo 12A Active speakers and ideal for slightly larger venues, school halls, pubs or private functions up to 350 people.

- 2x 12 inch Active Fortissimo** Code 248-250
- 1x Behringer Xenyx X2222USB Mixer with 8 mic inputs** Code 382-690
- 2x Leads XLRma - St Jack** Code 588-310
- 2x Speaker Stands** Code 448-300
- 1x Bag for stands** Code 458-920



If bought separately: £576+VAT	OUR PRICE £475+VAT	SAVE £120 (INC VAT)
--	------------------------------	----------------------------------

Description	Code	Price (Ex VAT)
Fortissimo 12	250-110	£475.00

Studiospares Gold PA Package

Serious and amazingly cost effective solution featuring the popular new Auditorium 212B speakers and the meaty Yamaha P7000 power amp. Great for large pubs, clubs and other venues up to 1000 people.

- 2x 12" Passive Auditorium** Code 248-830
- 1x Yamaha P7000** Code 264-850
- 1x Behringer SX3242FX Mixer with 24 mic inputs** Code 381-770
- 2x 5m Speakon Cables** Code 588-890
- 2x 5m XLR Leads** Code 588-270



If bought separately: £1133+VAT	OUR PRICE £1045+VAT	SAVE £105 (INC VAT)
---	-------------------------------	----------------------------------

Description	Code	Price (Ex VAT)
Gold	250-130	£1045.00

INDEX

Outboard	
Complete Channels	32
Noise Gates	32
Compressors	32
Compressor / Gates	33
Graphic Equalisers	33
Enhancers	35
Reverberation	35
Vocal Processors	36
Audio Signal Distribution	37
Multi Processors	38
General Effects	38
Microphone Preamps	39
Other Preamps	41
Receivers	42
Power Amps	42
Induction Loops	47
Crossovers	47

OUTBOARD

Complete Channels

DBX 2865

Processor



Delivers that "in your face" vocal performance, frequency tunable de-esser eliminating vocal sibilance and high frequency distortion as well as an enhancer to give sparkle and crispness to your tracks.

- Studio quality mic preamp
- Classic dbx compression
- Programmable expander/gate
- Insert jacks to add external processors

Description	Code	Price (Ex VAT)
2865	361-370	£160.33

OUTBOARD

Noise Gates

Behringer Multigate Pro XR4400

Professional Channel Strip



A popular solution where rack space or budgetary constraints apply, the Multigate is ideal.

- 4 independent expander/gates provides an ultra-fast gate <10 µ sec
- Programme-dependent expander reduces noise during signal pauses
- Reduces crosstalk between adjacent microphones

Description	Code	Price (Ex VAT)
Multigate Pro XR4400	360-090	£74.17

DELIVERY BEFORE NOON
no problem

Drawmer SP2120

Noise Limiter



Greatly benefits from Drawmer's 25 years experience in designing industry standard dynamic processing devices

The Drawmer SP2120 Speaker Protector offers both strict level control and tremendous peace of mind to the contractor, installer and venue in the knowledge that only the maintenance engineer and the venue manager hold a key. As its name suggests the 1U, two channel processor eliminates the possibility of 'unauthorised' excessive sound pressure levels on speaker systems which could result in damage to both chassis drivers and amplifier electronics.

Description	Code	Price (Ex VAT)
SP2120	361-000	£437.45

Drawmer SP2120-TPC

Security Cover

Security cover for the Drawmer SP2120 Noise Limiter.

Description	Code	Price (Ex VAT)
SP2120-TPC	379-340	£45.00

OUTBOARD

Compressors

Drawmer DL441

4 Channel Compressor/Limiter



An Industry Standard product which combines both hard or soft knee compression.

- Smooth recovery from compression
- Zero overshoot circuitry Auto Attack and Auto Release circuitry
- Peak Level response time is zero
- -10dB and +4dB operation and Stereo Linking 1 - 2 and 3 - 4

Description	Code	Price (Ex VAT)
DL441	359-621	£624.68

Art Pro VLA II

2 Channel Compressor



NEW LOWER PRICE

Two Channel tube driven compressor / levelling amplifier.

- Vactrol based optical electronic circuitry rather than the more typical design VCA driven level detection circuit
- XLR and 1/4-inch TRS balanced inputs and outputs
- +4dBu/-10dBu mode switch
- Enhanced Link Mode optimising use as a mastering tool
- LED Backlit VU Input/Output Indicates Both Average Level And Peak Hold
- VCA-Less Vactrol Opto-Compression Design

Description	Code	Price (Ex VAT)
VLA II	325-730	£240.83

Behringer Composer Pro XL MDX 2600

Compressor



The Composer Pro is a popular processor which provides interactive control over the signal dynamics. The dynamics section includes a voice-adaptive deesser and a dynamic enhancer. The Interactive Knee Adaption Compressor which combines hard knee technology with current soft knee circuitry. An expander section includes Ratio circuitry which adapts the time constants to the programme material to avoid premature gate closure. A Clipper/Peak limiter brickwalls the signal for short transients and then reduces the overall output level. Attack and Release times can be set manually or automatically. -10dB/+4dB operation. Jack/XLR connectors.

Description	Code	Price (Ex VAT)
Composer Pro	359-200	£74.17

MORE PRODUCTS online

Behringer Multicom PRO XL MDX4600

4-Channel Compressor



NEW LOWER PRICE

Packs a lot of processing power into 1U of rack space.

Much of the manufacturing cost is in metal work and power supplies. The cost of additional channels is minimal so such units provide good value for money. All channels are identical. The Multicom unusually features both the famous soft/hard knee compression techniques. The soft knee curve is musically more acceptable and easier to set. Hard knee is more predictable and defines the parameters so is favoured by many. Programme dependent Attack and Release times provide for easy setting up. Controls are provided for Ratio, Threshold and Output level. An eight point LED ladder provides the appropriate gain reduction information. The Interactive Auto Compressor provides inaudible compression. The advanced program-adaptive expander gate makes control settings much more accurate. The MDX4600 can be configured in many ways which further increases its versatility. Inputs and outputs balanced/unbalanced on Jacks and XLRs. Channels are linkable.

Description	Code	Price (Ex VAT)
MDX4600 Multicom Pro	359-970	£87.50

OUTBOARD

Compressor/Gates

Samson 5 Com 4

Four Channel Compressor/Gate



Provides 4 channels of quality dynamic processing with an Expander/Gate and Compressor/Limiter on each channel.

- Channels operate independently or in stereo pairs
- Multi-segment LED metering displays plus gain reduction
- Expander/Gate section features a variable Threshold control
- Fast or slow release times
- Enhancers for high frequencies restoration
- Switches from soft to hard knee based on the level of input signal applied

Description	Code	Price (Ex VAT)
5 Com 4	368-530	£133.32

dbx 166XS

Compressor Limiter Gate



The 166XS compressor/limiter/gate provides smooth and musical Auto Dynamic performance. Able to give greater clarity to vocals, sustain guitars and fatten drums, plus it protects your equipment from large transients.

- New gate algorithms
- Program-adaptive expander/gates
- Stereo or dual-mono operation
- Side Chain insert
- Classic dbx "Auto" mode

Description	Code	Price (Ex VAT)
166XS	361-660	£185.00

Alesis 3632

Gated Compressor/Limiter/Expander



The 3632 provides two independent, full-featured compressor/limiters in one compact rack.

- Stereo compressor/expander/limiter/gate for complete dynamics management
- Minimised signal path for optimal sound quality
- Intelligent Knee for musical performance with soft and hard-knee envelopes
- Sidechain send and return for use in an external effects loop

Description	Code	Price (Ex VAT)
3632	385-690	£83.32

dbx 266XS

Compressor/Gate/Expander



The DBX266XS is a compressor/limiter/gate 1U rack mountable unit for your live sound rig or studio giving you more dynamic control to help create a more polished output. Having compression in your audio chain gives you the ability to smooth out uneven levels, add sustain to guitars and fatten up your drums. It also makes it easy to bring vocals to the front of your mix - adding greater clarity and making them stand out from the surrounding instruments. New gate timing algorithms ensure the smoothest release characteristics. Great sounding dynamics control for any type of programme material. Separate precision LED displays for gain reduction, compression threshold and gate threshold allow quick, accurate setup. Stereo or dual-mono operation. Balanced inputs and outputs on 1/4" TRS and XLR connectors. Side Chain insert. Classic dbx® "Auto" mode.

Description	Code	Price (Ex VAT)
266XS	359-670	£102.50

Art SCL2

Stereo Compressor Limiter Gate



Highly sophisticated and flexible dynamics processor designed for easy operation and great tone.

- Dual Channel or Linked Stereo Operation
- 1/4-Inch TRS Side Chain Inserts
- 1/4-Inch TRS And XLR Balanced Inputs
- 1/4-Inch TRS And XLR Balanced Outputs
- Stereo Mode Balance Control

Description	Code	Price (Ex VAT)
SCL2	326-070	£115.83

OUTBOARD

Graphic Equalisers

dbx 2155/2315

Graphic Equalisers



The 2-Series from dbx represents a major step forward in the performance of entry-level graphic equalizers. From their amazing 10Hz to 50kHz frequency response, to the 108dB dynamic range and internal toroidal transformers, the 2-Series offers fantastic specifications at an affordable price point. With 2/3 octave Constant Q frequency bands, XLR and TRS inputs and outputs and switchable boost/cut ranges of +/-6 or +/-12dB. Sure to find a home in the studio, on tour and with installed sound venues.

Description	Code	Price (Ex VAT)
2155 2x 15-band EQ	359-680	£100.00
2315 2x 31-band EQ	359-690	£124.17

Behringer Ultragraph series

Graphic Equalisers

Following the incredible success and popularity of the Ultra-Graph Pro, Behringer have now developed the original idea into a series of Ultra-Graphs, with one to suit just about all requirements:

Behringer Ultragraph Pro FBQ6200

The Behringer Ultragraph Pro FBQ6200 is an 'ultra-musical' 31-band stereo graphic equaliser offering great performance and flexibility in both live and studio applications. Its FBQ Feedback Detection System instantly reveals feedback frequencies and also can be used as an audio analyzer. It has dedicated limiters with gain reduction meters for each channel, to protect your sound system from overload and distortion. Also featuring high and low cut filters, accurate LED metering, high-quality illuminated 45mm faders and illuminated switches, this should be a useful and reliable addition to your kit.



Behringer Ultragraph Pro FBQ3102

The Behringer Ultragraph Pro FBQ3102 is a professional 31-band stereo graphic equaliser for both live and studio applications. Its FBQ Feedback Detection System instantly detects feedback frequencies and can also be used as an audio analyser, making the FBQ3102 a welcome addition to your PA setup. Adding some extra oomph to your music is made easy with the dedicated mono subwoofer output with adjustable crossover frequency. You can effortlessly remove unwanted frequencies such as floor rumble and tape hiss by utilizing the additional sweepable high and low cut filters for each channel, and level setting is easy with the highly accurate 12-digit LED input/output metering and input gain control. With its comprehensive features and quality craftsmanship, the FBQ3102 will not let you down.



Behringer Ultragraph Pro FBQ1502

The Ultragraph Pro FBQ1502 is a professional, 'ultra-musical' 15-band stereo graphic equalizer very similar to the 2 above, but only 15-band.

Behringer Ultragraph DEQ1024

The Ultragraph DEQ1024 is an ultra high-resolution digital stereo 31-band equaliser feedback destroyer. It combines unmatched digital performance with straightforward and intuitive analogue-like operation. The revolutionary FBQ Feedback Detection System instantly detects critical feedback frequencies and can also be used as an audio analyser, making the DEQ1024 a must-have for every professional touring rack. Switching on the automatic Feedback Destroyer removes feedback within a fraction of a second. A state-of-the-art 24/48-bit DSP and ultra high-resolution 24-bit/96kHz A/D and D/A converters deliver the ultimate in sonic resolution. In short, you get top-notch performance, analogue feel, ease of use, and abundant connectivity options, all of which make the DEQ1024 an ideal tool for both live and studio applications.



Description	Code	Price (Ex VAT)
FBQ6200	370-420	£120.83
FBQ3102	370-430	£83.32
FBQ1502	370-440	£57.50
DEQ1024	370-250	£115.83



OUTBOARD

Graphic Equalisers

CONTINUED

Studiospares Trojan EQ Series

Graphic Equalisers

This range of Graphic equalisers provide all the facilities at a modest price through purchasing direct from the factory and selling direct to the customer. Nothing is compromised.

A variable low cut filter operates between 10Hz and 250Hz. An LED ladder indicates the onset of overloading. Each frequency band can have 12dB boost or cut. An output transformer avoids making ground loops when interfacing with other equipment as does a gain control allowing for differing equipment signal levels.

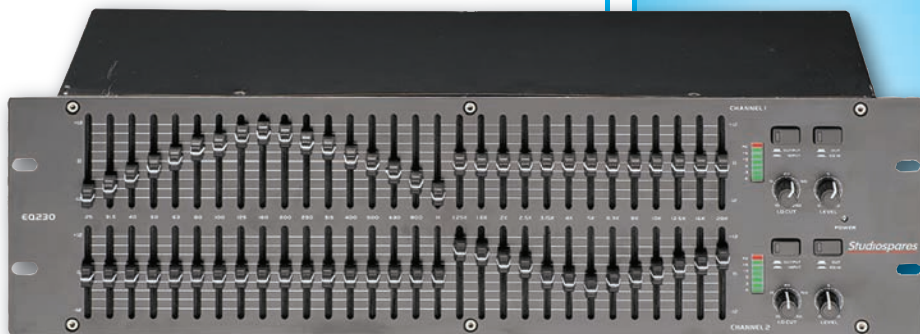

This range of Graphic Equalisers share common facilities including two switches for bypassing EQ circuits and total bypass linking input to output.

Model	Description	Size
EQ215	15 frequency bands spaced at 2/3rd octaves with 35mm sliders	1U high
EQ231	31 frequency bands of ISO spaced frequencies at 1/3 octave intervals with 35mm sliders	2U high
EQ230	31 frequency bands of ISO spaced frequencies at 1/3 octave intervals with 55 mm sliders	3U high

Description	Code	Price (Ex VAT)
EQ215	348-130	£58.30
EQ231	348-140	£93.50
EQ230	348-150	£119.00

Behringer Ultracurve Pro

DEQ2496

Graphic Equaliser



High quality mastering processor ideal for audiophile mastering and PA purposes.

The ULTRACURVE PRO DEQ2496 is an ultra high-precision digital 24-bit/96 kHz EQ/RTA mastering processor. Its high quality audio performance makes it ideal for audiophile mastering and PA purposes. There are 4 concurrently selectable EQ modules (31-band graphic EQ, 10-band parametric EQ, Feedback Destroyer and three dynamic EQs per channel). The DEQ2496 features high-quality AKM@ 24-bit/96kHz A/D and D/A converters and two high-performance digital signal processors for ultimate sonic resolution and 113dB dynamic range. The DEQ2496 also boasts balanced inputs and servo balanced outputs with gold-plated XLR connectors, stereo aux output, AES/EBU and SPDIF inputs and outputs (XLR and optical). The internal switchmode power supply assures maximum flexibility (100 - 240V), noise-free audio, superior transient response and lowest possible power consumption.

Description	Code	Price (Ex VAT)
Ultracurve Pro	370-230	£182.50

dbx 1231

Dual 31-Band Graphic Equaliser



High quality, respected and designed for the most demanding applications.

- Selectable +/-6dB or +/-15dB boost/cut range
- Ins and outs via XLRs, 1/4 inch Jack connectors and barrier strip
- Balanced inputs and outputs
- Chassis/signal ground lift facility for earth loop isolation
- Switchable 40Hz/18dB per octave low-cut filters and 45mm faders

Description	Code	Price (Ex VAT)
1231	379-210	£249.00

dbx 2155/2315

Graphic Equalisers



The 2-Series from dbx represents a major step forward in the performance of entry-level graphic equalisers. From their amazing 10Hz to 50kHz frequency response, to the 108dB dynamic range and internal toroidal transformers, the 2-Series offers fantastic specifications at an affordable price point. With 2/3 octave Constant Q frequency bands, XLR and TRS inputs and outputs and switchable boost/cut ranges of +/-6 or +/-12dB. Sure to find a home in the studio, on tour and with installed sound venues.

Description	Code	Price (Ex VAT)
2155 2x 15-band EQ	359-680	£100.00
2315 2x 31-band EQ	359-690	£124.17

SATURDAY DELIVERY

no problem

DELIVERY BEFORE 10AM

no problem

OUTBOARD

Enhancers

Behringer Shark FBQ100

Feedback Destroyer

A high performance single channel Feedback Destroyer with integrated microphone preamp, delay line, noise gate and compressor.

Automatically and "intelligently" locates and destroys up to 8 feedback frequencies. Narrow FBQ filters for extremely effective feedback suppression, while keeping highest sonic quality. Ultra-low noise Mic/Line input with Gain control and +48V phantom power. Delay line with up to 2.5 seconds of delay, adjustable in metres, feet and m/sec. Noise gate with automatic and manual parameter settings.



NEW LOWER PRICE

Description	Code	Price (Ex VAT)
Shark FBQ100	383-010	£57.50



Behringer Feedback Destroyer Pro

Feedback Suppressor



NEW LOWER PRICE

The fastest and the only 96kHz Feedback Suppressor on the market!

Using an ultra-fast feedback detection algorithm, the FBQ2496 automatically and "intelligently" locates up to 20 feedback frequencies per channel and sets extremely narrow notch filters to destroy them, leaving the remainder of the signal virtually untouched. Easy does it: with the "Set-and-Forget" default setting plus the Panic button, your feedback destroyer can be up and running in no time! The auto mode continuously monitors the mix, resetting programmed filters automatically, while the manual mode allows individual setting of up to 40 fully parametric filters with frequency, bandwidth and gain adjustment. Open MIDI architecture means that future software updates and flexible communication with digital equipment are straightforward. With its various modes you can master just about any live sound situation or use it as a creative sound-shaping tool.

Description	Code	Price (Ex VAT)
FBQ2496	380-250	£115.83



Behringer Sonic Exciter SX3040

Realtime Analyser



Produces natural brightness through harmonic enhancement and tighter bass with increased punch through phase compensation.

- Tighter bass with increased punch
- Dedicated Tune, Harmonics and Mix controls
- Dedicated Drive, Tune and Mix controls per channel on the Bass Processor
- Balanced inputs and outputs with 1/4in Jacks and Gold XLR connectors

Description	Code	Price (Ex VAT)
SX3040	381-620	£59.99

NEW LOWER PRICE

Behringer Micro HD400

Hum Destroyer

This ultra-compact 2-channel solution removes AC hum and noise quickly, easily and reliably.

- Automatically converts unbalanced signals into balanced without any loss
- Jack inputs and outputs for 2 mono or 1 stereo signal



NEW LOWER PRICE

Description	Code	Price (Ex VAT)
Micro HD400	380-270	£20.82

DELIVERY BEFORE NOON
no problem

Behringer FBQ1000

Feedback Destroyer

NEW LOWER PRICE



High-performance 2-channel feedback destroyer and parametric EQ.

- Fastest feedback suppressor on the market, with a response time of less than 0.2 seconds
- Ultra-narrow FBQ filters for extremely effective feedback suppression
- "Set-and-forget" default setting for easy operation
- Rugged construction ensures a high level of durability.

Description	Code	Price (Ex VAT)
FBQ1000	383-000	£87.50

OUTBOARD

Reverberation

Alesis Microverb 4

Multi Effects Processor



A sophisticated digital programmable Multi Effects Processor using 18 bit linear P.C.M. technology to provide a 90dB dynamic range.

- 256 instantly accessible preset programmes
- 112 Reverb, 32 Gated/Reverse, 80 Delay and 32 Multi-tap
- Reverbs have variations on decay time, tonal character and reflections
- Two band EQ at 100Hz and 4kHz for fine tuning and effect
- Operation is simplicity itself

Description	Code	Price (Ex VAT)
Microverb 4	359-140	£95.82

Lexicon MX200

Dual Reverb/Effects Processor



Popular Dual Reverb/Effects Processor from Lexicon. Whether you're looking for raw processing power with instant front-panel access for live performance, or seeking rich, smooth and complex processing algorithms in the studio, Lexicon brings the best of both worlds together in the MX200. Designed with both live sound reinforcement and home recording in mind, MX200 features the deep, rich reverb and effects algorithms that built the Lexicon legend, and adds increased versatility with speciality effects and dbx dynamics. Each of the 32 stunning reverbs and effects and their parameters are all instantly accessible within a single button push or knob turn on the intelligently designed front panel without wading through bank after bank of tedious menus. Add powerful Editor/Librarian and VST / Audio Units software, and bring 35 years of Lexicon heritage to your desktop.

Description	Code	Price (Ex VAT)
MX200	360-870	£159.00

PRICE changes

This catalogue was priced on 1st December 2014.

Current prices may be higher...

see our website for up to date prices.

ALL PRICES EXCLUSIVE OF VAT.

OUTBOARD

Vocal Processors

TC Helicon Voicetone R1

Vocal Processor

Adds studio reverb polish to live vocals by offering pro acoustic spaces from lush halls to tight ambience.

- Effect can be activated via MP-75 mic
- Reverb styles, Hall, Plate, Theatre, Ambience, Arena, Club, Room,
- XLR Mic preamp with phantom power
- Selection of 8 vocal thickening reverb styles



TC Helicon Voicetone T1

Vocal Processor

Applies compression, de-essing and EQ to bring out your best tone without the hassle.

- Effect can be activated via MP-75 mic
- Multiband EQ processor compares your voice to an ideal "target" and adapts accordingly
- Shape, brightens and tightens vocals
- Warmth adds depth without mud
- Balanced XLR output



TC Helicon Voicetone X1

Vocal Processor

Intensifies your vocals with its wide range of filtered and distorted sounds.

- Drive and Filter controls adapt to your voice and modifies distortion
- Bandwidth Control produces perfect phone effect
- Effect can be activated via MP-75 mic
- 3x Megaphone/Telephone effects
- 2x Distortion types, 3x Amp effects
- XLR Mic preamp with phantom power
- USB connects to Voice Support



TC Helicon Voicetone E1

Vocal Processor

Offers singers the signature echo and slapback effects that evoke classic songs and adds a wide range of echo effects for more depth in your vocals.

- Footswitch tapping can set echo times to song tempo
- Effect can be activated via MP-75 mic
- Wide selection of delay styles
- Filter control with smart EQ band limiting
- Mix gives control over Echo level



Description	Code	Price (Ex VAT)
R1	386-490	£100.00
T1	386-520	£77.00
X1	386-530	£77.00
E1	386-540	£100.00

TC Helicon Voicesolo FX150

Vocal Processor

A well thought out 3-Channel Digital Mixer with TC-Helicon Vocal Processing, including Reverb, intelligent EQ and Compression.

- 9 studio grade reverb styles
- Easy Grip mounting system, no time-wasting assembly needed.
- XLR/TRS combo inputs with phantom power and automatic mic/line switching
- 3-band EQ with individual channel control
- Hi-Z Instrument switch on Channel 1
- Voice Cancel on Aux channel



Description	Code	Price (Ex VAT)
FX150	386-560	£187.50

TC Helicon Voicetone Mic Mechanic

Vocal Processor

A complete vocal toolbox in a compact, easy-to-use pedal with quality FX including Reverb, Delay and Pitch Correction.

- Effect can be activated via MP-75 mic
- Adaptive Tone for the perfect mix
- Simple controls, instant effect
- Auto Chromatic Pitch Correction
- USB connects to Voice Support application
- XLR Mic preamp with phantom power



Description	Code	Price (Ex VAT)
Mic Mechanic	386-480	£107.50
Optional MP-75 Microphone	386-550	£107.50

TC Helicon Voicetone Correct XT

Vocal Processor

Smooth, pro vocal tone with the security of active anti-feedback plus TC-Helicon's natural auto-chromatic pitch correction.

- Effect can be activated via MP-75 mic
- Compressor, de-ess and adaptive Shape EQ
- Adaptive Gate reduces background noise
- XLR Mic input with phantom power
- Balanced XLR output



Description	Code	Price (Ex VAT)
Correct XT	386-500	£195.00
Optional MP-75 Microphone	386-550	£107.50

TC Helicon Voicelive Play GTX

Vocal Processor

The first ever combination of complete vocal and guitar processing.

- 200+ song & artist inspired presets for vocals & guitar.
- Key for harmonies and pitch correction set automatically from guitar input
- MIDI input allows NaturalPlay via your keyboard
- Plug an MP3 player to AUX input and sing along using Vocal Cancel feature
- Automatic backing harmonies, vocal double tracking, pristine EQ
- Compression, lush reverbs, hard-tuned robo-voice



TC Helicon Voicelive Touch 2

Vocal Processor

Automatically takes care of vocal tone with adaptive EQ, compression, de-essing and gating.

- Rhythmic effect creates Stutter and Chopper effects
- Natural Pitch correction to the infamous HardTune effect
- Perfect Harmonies, reverbs, delays, doubling and much more
- Jump between 36 performance functions fast in the Touch Matrix
- Easy, graphic icon-based editing
- 12 Effects including uMod, Choir, Harmony, Echo+Delay, VLOOP, Rhythm etc



TC Helicon Voicelive 3

Vocal Processor

3-in-1 professional performance system for vocals, guitar and phrase looping.

- TC Electronic stomp box effects, Amp Tones and dedicated stereo amp outputs
- Powerful 3-phrase looping
- Guitar chords automatically guide vocal Harmony, HardTune, Synth and Vocoder effects
- Independent outputs for vocal and guitar



TC Helicon Voicelive Rack

Vocal Processor



Combines a transparent mic preamp and adaptive pre-processing along with vocal effects, providing a plethora of vocal sound possibilities..

- Full mic channel with digitally controlled gain, phantom power and pre effects
- Direct access editing and performer control
- Over 200 factory or 400 user presets
- Up to 8 voices with MIDI keyboard control or 4 doubled harmony intervals
- Includes MP-75 Modern Performance Vocal Microphone with Mic Control

Description	Code	Price (Ex VAT)
Voicelive Play GTX	386-570	£132.50
Voicelive Touch 2	386-580	£340.83
Voicelive 3	386-590	£479.17
Voicelive Rack	386-600	£340.83

WANT a job?

Are you looking for a stable and rewarding career?

Studiospares are constantly expanding. We require additional staff for a variety of positions, working in a very congenial atmosphere. Practical experience of recording and/or live sound engineering would be preferable.

send in your CV in the first instance

DELIVERY BEFORE NOON
no problem

SATURDAY DELIVERY
no problem

VISIT
our trade counter

You'll get friendly advice and immediate access to 8000+ product lines!

MORE PRODUCTS
online

OUTBOARD

Audio Signal Distribution

ART DTI

Dual Transformer/Isolator

A high quality totally passive audio interface.

The DTI (Dual Transformer/Isolator) uses a pair of high performance transformers to totally separate input and output signal grounds, thereby isolating two systems and reducing hum and ground-loop noise. The DTI's audio transformers have an extremely flat and wide frequency response and can handle high signal levels while maintaining an isolated balanced output. This gives the DTI a very clean and neutral sound with a wide variety of signal sources. The transformers are wound for 1:1 unity gain and are designed to be used with impedances from 600 ohms to 100 kilohms. The DTI also features highly versatile connectivity, with XLR, 1/4" Jack, and RCA Phono connections on all inputs and outputs.



Description	Code	Price (Ex VAT)
DTI	325-310	£35.83



Sonifex RB-DA6

6 way Stereo Distribution Amplifier



A high performance 6 way stereo distribution amplifier for splitting a source into a number of different outputs

- 1 Stereo in and 6 stereo outs
- 1 mono in and 12 mono outs
- Splits a source into different inputs
- XLR inputs and outputs electronically balanced and/or unbalanced
- Each output is individually buffered
- Gain potentiometers

Sonifex RB-DA6G

Same as the RB-DA6G, but with output gain control.

Description	Code	Price (Ex VAT)
RB-DA6	368-050	£270.83
RB-DA6G	368-270	£290.83
Optional Rack Kit	368-140	£30.00

Art Cleanbox Pro

2 Way Stereo Converter

Two channels of unbalanced inputs (phono or minijack) to balanced pro line-level outputs (XLR)

- Each section has stereo level controls
- Conversion in reverse: balanced to unbalanced; Lighted On/Off switch
- Includes external power supply
- Rugged extruded aluminium case



Description	Code	Price (Ex VAT)
Cleanbox Pro	325-790	£46.80

Samson S Convert

Level Converter

A problem solver for interfacing and level matching consumer and professional audio equipment.

- +4 to -10 audio level converters
- RCA -10 inputs and outputs
- XLR +4 outputs; XLR +4 inputs with level control
- 18 Volt AC adaptor included



Description	Code	Price (Ex VAT)
S Convert	368-840	£39.99

Studiospares RED 502

Bi-Directional Converter



Single channel Passive Bi-directional Balanced to Unbalanced and vice/versa.

Superbly engineered from a die cast aluminium extrusion with metal endplates on which the connectors and switches are mounted. Input/Outputs are a standard quarter inch Jack socket and an RCA Phono socket. The other end has male and female XLRs as balanced inputs/outputs. Inputs to outputs are fully isolated from each other via a transformer. An earth lift switch is provided. Response 0.05dB down at 20Hz and 20kHz. Max input +28dBu. No power supply required. Metal XLRs throughout.

Description	Code	Price (Ex VAT)
RED 502	458-210	£22.80

PDF catalogue

Want this catalogue on your phone or laptop?

The Studiospares catalogue is now available in PDF format.

visit www.studiospares.com/page/pdfcatalogue/!

MORE PRODUCTS online

Focusrite Rednet Range

Audio Interfaces/Signal Distribution



RedNet is Focusrite's flagship range of modular Ethernet-networked audio interfaces that harnesses the power of Audinate's tried and tested Dante digital audio networking system to bring studio quality sound to any modern audio application.

Focusrite Rednet 1

Connects to your network with a single Ethernet cable.

- Eight channels of line-level analogue in and out
- 24-bit A-D and D-A conversion for superb audio performance
- 119dB dynamic range at sample rates up to 192kHz
- The rear panel includes standard DB25 connectors

Focusrite Rednet 2

Same as above but with 16 analogue channels instead of 8.

Focusrite Rednet 3

Interfaces your existing digital audio systems and components to the RedNet network.

- Up to 32 inputs and outputs and full software remote control
- Includes support for AES/EBU, S/PDIF and ADAT formats
- Allows the RedNet system to be synchronised to incoming signal clock or a word clock source

Focusrite Rednet 4

Adds eight of the latest remote-controlled Focusrite mic preamps / line inputs to your RedNet system.

- Eight high-quality Focusrite 'RedNet' mic preamps
- DC-coupled signal path for open and transparent sound
- Selectable line and DI inputs for input flexibility
- Dynamic range: 119dB; Mic input Level up to +16dBu

Focusrite Rednet 5

Connects your RedNet system to Pro Tools HD®.

- Each RedNet 5 can route up to 32 input and 32 output channels between your RedNet network and Pro Tools HD system
- Connecting six RedNet 5 units to a Pro Tools HDX system allows up to 192 inputs and outputs
- Compatible with Pro Tools HD@ TDM system

Focusrite Rednet 6

Allows multiple channels to be carried along a single interface.

- Provides the link between your RedNet Ethernet-based audio system and any MADI / AES10 setup
- Supports up to 64 channels of both coaxial and optical MADI interfaces
- External Word Clock I/O for either RedNet or MADI

Focusrite Rednet D16

1U 16-channel AES3 I/O for Dante audio networks.



- Ethernet Redundancy
- Sample Rate Conversion on all input channels
- Input and Output on XLR as well as DB25

Focusrite Rednet PCIe Card

For situations in which low-latency performance is critical.

- 128 channels in and out
- Compatible with any Dante network
- Up to 192 kHz sample rate
- Under 3ms analogue-to-analogue round-trip latency (Dependent on ASIO/Core Audio buffer size)



Description	Code	Price (Ex VAT)
RedNet 1	389-920	£1332.50
RedNet 2	389-930	£2040.83
RedNet 3	389-940	£999.17
RedNet 4	389-950	£1540.83
RedNet 5	389-960	£665.83
RedNet 6	389-970	£1332.50
RedNet D16	392-040	£1082.50
RedNet PCIe Card	389-980	£665.83

OUTBOARD

Audio Signal Distribution

CONTINUED

Drawmer D-Clock-R DMS-6

Distribution Amplifier



Developed for studio recording, live and broadcast environment, where reliability and stability are absolutely imperative.

- 16 character blue LCD display provides a reference measurement of the incoming sample rate to an accuracy of 2ppm
- Fitted with two identical and independent power supplies
- Auto-Sensing Dual Redundant WordClock/ AES3id BNC Inputs provide continuous operation and added dependability.
- Default and auxiliary, capable of locking on to both word clock and AES-3id
- 12 BNC rear panel and 4 front panel clock outputs

Description	Code	Price (Ex VAT)
DMS-6	379-640	£650.00

Alice DA-PAK

Distribution Amplifier



Distribution amp intended as a mixer output splitter for feeding several inputs from one stereo output.

- Stereo input to 4 stereo output
- Inputs are balanced and bridging, outputs are balanced
- Outputs may be individually wired unbalanced if required
- Case designed to be free standing or to fit into woodwork
- Connectors are Neutrik XLR type, mains input is via an IEC connector

Description	Code	Price (Ex VAT)
DA-PAK	361-870	£159.00

OUTBOARD

Multi Processors

Behringer Virtualizer 3D FX2000

Multi Effects Processor



NEW
LOWER
PRICE

Get even more mind-expanding power for your keyboard, bass, guitar or vocals with the Virtualizer Pro 3D FX2000 Effects Processor.

This amazing rack unit has 71 incredible new algorithms, including true studio-grade stereo and 3D effects that will add a head-spinning new dimension to your sound, both live and in the studio. The FX2000 employs Behringer RSM (Real Sound Modeling) technology to simulate acoustic environments with stunning accuracy. Effects options include powerful modulation, amp simulation, distortion and special effects, as well as effective dynamic and psychoacoustics processing. Performance is further enhanced through user-addressable high and low EQ and wave-adaptive Virtual Room reverb algorithms. Accurate LED level meters for perfect level setting and optimum performance. Servo-balanced XLR and 1/4" TRS inputs and outputs. High-quality components and exceptionally rugged construction ensure long life.

Description	Code	Price (Ex VAT)
Virtualizer 3D FX2000	383-230	£74.17



Lexicon MX300

Multi Processor



A quality reverb unit from Lexicon. All parameters are controllable via a PC (VST) or Macintosh (AU) with the included plug in, this allows for total recall of settings via USB. Included are sixteen Lexicon reverbs, seven delays, modulation effects along with compression and de-essing from dbx. Three parameter knobs allow for intuitive parameter editing and five effects routing options make the MX300 extremely flexible. The unit has 2 inputs and outputs on both XLR and 1/4" TRS Jack. Also included are a MIDI input and output.

Description	Code	Price (Ex VAT)
MX300	379-130	£199.00

Empirical Labs EL8XS

Distressor Brit Mode



NEW

Digitally Controlled Analogue Knee Compressor.

- All 8 of the Distressor's curves are distinctive intentional
- The "Nuke" setting - a brick wall limiting curve for live drum room mics
- Three modes that colour the signal, even without compression
- 10:1 "Opto" ratio
- Distort 2 emphasises tube-like 2nd order harmonics

Description	Code	Price (Ex VAT)
EL8XS	900-275	£2245.00

THE website

Keep up to date with all the latest products and current prices on the Studiospares website!

check out www.studiospares.com

1000s of products

Available from stock!

DID you know?

At Studiospares we process all incoming orders within a few minutes

If anything is to be added to an earlier order, it will be processed as a NEW order.

Behringer Eurocom SPL3220

Sound Processor



Professional multiband sound processor for public address, broadcasting and mastering applications. Maximises signal density for public address and broadcast sound.

- Leveler automatically adjusts signal density
- Controls the max sound pressure level
- Increased speech intelligibility for PA use
- Interactive Knee Adaptation compression

Description	Code	Price (Ex VAT)
SPL3220	383-990	£90.83

OUTBOARD

General Effects

Stagline VU-800/SW

Audio DB Display



Audio Meter with LED dB display. 3-colour LED display with 40 LEDs. Switchable display mode (dot display or bar graph display).

Description	Code	Price (Ex VAT)
VU-800/SW	255-760	£44.30

VISIT our trade counter

You'll get friendly advice and immediate access to 8000+ product lines!

free parking for 40 cars

FOR fax orders

Use our fax number...

020 8450 4390

OUTBOARD

Microphone Preamplifiers

Centrance Micport Pro

USB Microphone Preamplifier



The easiest way to capture a professional-quality vocal take, communicate with clarity over Skype or record studio-grade instrument samples

- 24-bit/96 kHz A/D converter for extra clarity
- 103.5dB dynamic range with
- 48V phantom power
- Loud headphone amp for zero latency monitoring
- Stereo capability
- Sturdy aluminium body that's only 4.5 inches (11.5 cm) long

Description	Code	Price (Ex VAT)
Micport Pro	219-630	£116.00

Eventide Mixing Link

Mic Preamp with FX Loop

A compact stompbox form factor with an effects loop.



- High Quality mic preamplifier with FX loop in a compact package
- Effects loop send and return for balanced and unbalanced signals
- Latching or momentary footswitch control of effects loop
- Aux I/O connection
- 9VDC power supply included, or 9V battery
- 48V phantom power for condenser microphones
- Balanced XLR output which supports DI and Line levels



Description	Code	Price (Ex VAT)
Mixing Link	900-280	£199.17

Behringer Ultragain Pro MIC2200

Microphone Pre-Amplifier/Line Driver/DI Box



Uses ultra-quiet and transparent mic pre-amplifiers to let the true colours of even your finest microphone shine through.

- Discrete mic/line preamp with 12AX7 tube
- Wide bandwidth from 10Hz to 200kHz
- Integrated fully parametric EQs
- Independent line driver for converting -10 dBV into +4 dBu pro level
- Fully tunable and switchable 12 dB high-pass filter
- Servo-balanced I/O with 1/4" TRS and gold-plated XLR connectors

Description	Code	Price (Ex VAT)
Ultragain	360-700	£55.83

Tritonaudio Fethead Series
Microphone Preamps

A range of high quality, in-line preamplifiers providing improved sound for microphones.

Tritonaudio Fethead

FetHead is a high quality, phantom powered in-line preamplifier providing improved sound for ribbon and dynamic microphones. The electronics are housed in a robust metal chassis with a balanced 3-pole female XLR input and a balanced 3-pole male XLR output, rugged enough for use at home, in the studio or on tour. When mated with a high-end dynamic microphone like a Sennheiser MD441, or Shure SM7 FetHead really shines. Some ribbon microphones do not tolerate phantom power, FetHead's circuit uses Phantom power but shields it from its input (and the microphone's output). As a result it offers effective protection to the microphone. Fethead uses low noise jfets configured as a double class A amplifier. Attach FetHead on to a balanced microphone cable and plug it in a dynamic microphone, switch on phantom power and enjoy FetHead's Natural open sound!



Tritonaudio Fethead Filter

FetHead Filter is a Fethead version with a built-in 6dB/octave high pass filter with a corner frequency of 220Hz (other cutoff frequencies available on request). It is specially designed for microphones which exhibit an excessive proximity effect / low frequency response, like long motor ribbon microphones. The components which make up the filter are not directly in the signal path but are applied to the components which set the gain of FetHead Filters amplifier, thus making it frequency dependant. This way the sonic character which makes a FetHead attractive to the ear is preserved.



FetHead Filter can be distinguished by a green dot below the TritonAudio label.

Tritonaudio Fethead Phantom

FetHead Phantom is a FetHead version which allows phantom power to reach the microphone. It was developed after several requests from different audio engineers to build a FetHead for condenser microphones with low output. We tested FetHead Phantom on a broad range of condenser microphones and are very happy with the results. It works well with electret microphones like the countryman or an AKG C1000. These are microphones which consume very little power, FetHead Phantom also works great on "real" condenser microphones like a U87 or even with an Oktava MK319 which consumes a hefty 8mA!



FetHead Phantom can be distinguished by a red dot below the TritonAudio label.

Tritonaudio Fethead Broadcast

FetHead Broadcast was developed in conjunction with Dutch Broadcasting and facility service company CineVideoGroup. It is Based on technology used in our product FetHead and is fitted with a high quality jfet preamp, followed by a low impedance output buffer to enable output to drive cables up to 3 kilometres long. 23dB's of low noise amplification. For both dynamic and condenser mics. Low output impedance downs interference and low noise Class A jfet amplifier. Internal supply power filtering. Reverse polarity protection.



Description	Code	Price (Ex VAT)
Fethead	314-000	£59.00
Fethead Filter	314-010	£60.42
Fethead Phantom	314-020	£62.50
Fethead Broadcast	314-030	£115.00



Art Tube MP Studio V3

Microphone Preamplifier

Functions as a direct box - impedance matching, amplifying and improving the sound of any instrument plugged into it.



- Variable Valve Voicing
- Output Protection Limiting
- 12AX7A provides 70dB of gain
- Smooth and warm sound quality
- Variable input/output gain control
- XLR and 1/4" inputs/outputs

Description	Code	Price (Ex VAT)
Tube MP Studio V3	325-440	£57.50

Art Tube MP

Microphone Preamplifier

For a minimal investment, a Tube MP can provide the single largest improvement to the sound of your studio.



- For mics, instruments and line level sources
- Variable input/output gain controls
- XLR/1/4" inputs and outputs
- Phantom power
- Phase reversal switch

Description	Code	Price (Ex VAT)
Tube MP	325-430	£32.50

FREE catalogue
Are you reading someone else's catalogue? Why not call us and order your own copy...
it's free!

DELIVERY BEFORE NOON
no problem

SATURDAY DELIVERY
no problem

ALL PRICES EXCLUSIVE OF VAT.

OUTBOARD

Microphone Preamplifiers

CONTINUED

SM Pro EP84

8 Channel Mic Line Preamp/Splitter

A sturdy and comprehensive preamp with independent variable gain control.

- Mic sensitivity 60dB. Max 9.5dBm
- XLR/Jack inputs and outputs
- Line In Min sensitivity: -35dB Max +32 dB
- Peak LED on each channel
- -20dB Pad per channel
- 80 Hz Low cut filter per channel
- Output: Impedance: 600 Ohms
- S/N: > 105dB. Max Gain: 58dB



SM Pro PR8E

8 Channel Mic Line Preamp

PR8E's single circuit board design results in an exceptionally low noise pre-amp boasting a very high gain structure.

- Balanced XLR/TRS jack 'Combo' input
- 48V phantom power switch and a -20dB pad
- Line Input: Impedance 47K sensitivity -35dB
- Output: Impedance 600Ω Peak out +23dB. Max Gain: 58dB
- Peak Light Per channel.



Description	Code	Price (Ex VAT)
EP84	303-100	£233.30
PR8E	303-110	£124.99

SM Pro TC01/TC02

Tube Preamp/DI Box



A CLASS A tube preamplifier featuring selectable phantom power, phase reversal, adjustable -20dB PAD, and an in-line optical compressor.

- Hand tested 12AX7 Tube
- CLASS A Transformerless high voltage signal path for low noise and huge headroom
- Low output impedance allows long cable runs
- Level displayed on a VU meter
- Inputs and outputs on XLR and Jacks
- Front panel instrument input via Jack plug
- TC02 same as TC01 but with 2 channels and a full rack width

Description	Code	Price (Ex VAT)
TC01 1 Channel	303-080	£99.99
TC02 2 Channel	303-090	£124.99

SM Pro Q-PRE

4 Channel Mic Line Preamp

A compact and stylish product with a full range of gain control from -20dB to +40dB

- 4x XLR Input channels with Peak LEDs
- Phantom On/Off per pair of channels
- Minimum Sensitivity -40dB Peak level +5dB
- Gain control range 50dB
- Peak output level +18.5dB
- 4x balanced Jack outputs.



Description	Code	Price (Ex VAT)
Q-PRE	303-120	£74.99

Art Micromix

Phantom Powered Mic Preamp

An inexpensive mic preamplifier which is well thought out.

- Maximum gain 50dB (XLR), 44dB (1/4")
- Input impedance 10K Ohms
- Phantom power +36 volt
- Power and clip LEDs
- 12V DC adapter included
- XLR line out and unbalanced 1/4" Line/Headphone out



Description	Code	Price (Ex VAT)
Micromix	325-020	£37.50

Art TPS II

Tube Preamplifier



Designed as the ideal preamp for any application, the tube driven TPS II adds warmth and texture to any audio source.

- Variable input impedance
- Improved V3 variable valve voicing presets
- LED input meter with analogue output meter
- Wide frequency response (5Hz/50kHz)
- Enhanced ART tube technology adds warmth
- Automatically switches between instrument and mic preamp

Description	Code	Price (Ex VAT)
TPS II	325-520	£139.00

Art USB Dual Pre PS

2 Channel Preamplifier



Designed to work over a wide variety of applications from remote field recording to desktop/studio tracking. The ART USB Dual Pre Project Series is a full-featured high quality dual portable in a compact rugged case. Each of the two input channels has up to 48 dB of clean gain, phantom power, signal present and clip LED indicators. Inputs can be either XLR balanced or 1/4-inch TRS. It can be externally powered from the mains via a 12 Volt DC adapter (not supplied), or from an internal 9 Volt battery, or from the USB bus itself. Also included is a headphone output which allows latency free operation for a complete recording solution to track on a computer based system.

Description	Code	Price (Ex VAT)
USB Dual Pre	325-740	£65.83

Audient Mico

2-Channel Microphone Preamplifier

NEW



Compact, feature packed twin microphone preamplifier with built-in ultra-high quality analogue digital conversion.

- One channel creates a vintage style character and complexity
- Twin Class A Mic Preamps on XLRs/Jacks and switchable 48v phantom power
- AES/EBU, S/PDIF Coaxial and TOSLINK outputs
- Variphase - phase shift between 0-180°. Also Phase invert
- -20dB Pad - 18 to 66dB gain continuously variable
- Ultra-high performance 24 bit 44.1/48/96kHz internal clock
- Word Clock input on BNC; Switchable Word Clock termination

Description	Code	Price (Ex VAT)
Mico	201-030	£331.67

Audient ASP880

8-Channel Microphone Preamplifier

NEW



Audient's renowned console mic pres, pristine converter technology and a feature set that includes Variable Impedance and Variable High Pass Filters.

- All new, Burr Brown AD converter technology
- Variable Input Impedance with variable High Pass Filters
- 8 Insert points between the mic preamps and AD converters
- 2 Channels of Class-A Discrete JFET D.I instrument inputs
- Digital Outputs - ADAT, AES & S/PDIF

Description	Code	Price (Ex VAT)
ASP880	201-040	£749.17
ASP8SPDIF-Cab Cable	201-050	£75.00
ASP8AES-Cab Cable	201-060	£75.00

Behringer Minimic MIC800

Microphone Preamplifier

NEW LOWER PRICE



Endows your vocals, guitars, bass or synth with low-noise tube-like warmth both in the studio and on stage.

- Ultra-flexible preamp modelling with sophisticated output limiter
- Choose between 16 preamp voicings
- Authentic VTC tube modelling technology and dedicated low cut filter
- Vintage-style VU meter for precise level indication

Description	Code	Price (Ex VAT)
MIC800	380-190	£41.50

Presonus Tubepre v2

Microphone Preamplifier

A fully professional tube preamp, with dual-servo (no capacitors) gain stage letting you boost the program signal to very hot levels without increasing background noise.

- XMAX Class A preamp technology
- 12AX7 Dual-servo vacuum tube output stage
- 80Hz High-Pass Filter
- Polarity-reverse switch
- -20dB Pad



Description	Code	Price (Ex VAT)
TubePre v2	328-580	£74.17

WANT a job?

Are you looking for a stable and rewarding career?

Studiospares are constantly expanding. We require additional staff for a variety of positions, working in a very congenial atmosphere. Practical experience of recording and/or live sound engineering would be preferable.

send in your CV in the first instance

MORE PRODUCTS online

Studiospares RED 501

Microphone Preamplifiers

A range of high quality, in-line preamplifiers providing improved sound for microphones.

The maximum gain is 60dB. Maximum input level -3dBu. Maximum output level +26dBu. It generates 48V Phantom Power which can be switched off. A Low Cut switch switches in a high pass filter to attenuated frequencies below 90Hz. There is a 3.5mm Headphone Socket, a +12V DC input socket, Signal Present LED, Phantom Power LED and Clip LED when the signal clips through overloading the input. There is also an overall On-Off switch. Ins and outs via 3 pin XLRs. Metal XLRs throughout.



Description	Code	Price (Ex VAT)
RED 501	458-200	£26.30



PreSonus TubPre

Microphone Preamplifier



PreSonus TubePre Single Channel Microphone Preamp with VU Meter. Phase reverse. The TubePRE is a high quality vacuum tube preamp. Loaded with the PreSonus dual servo preamplifier, the TubePre affordably delivers low noise tube warmth for vocals, guitars, bass guitars, synths and sound modules. It noticeably outperforms preamps in low cost mixers and recording interfaces making it an easy choice for anyone desiring to enhance their recordings with the warmth of valves. Features · Dual Servo Tube-Preamp · Low Price High Performance · Tube Drive and Gain Control · -20dB Pad and Phase Reversal · +48V Phantom Power · 80Hz Rumble Filter · Back-Lit VU Meter · XLR and 1/4" Output · Great as a Direct Box

Description	Code	Price (Ex VAT)
TubePre	328-030	£74.17

Studiospares RED 520

Microphone Preamplifier



The latest model in the Studiospares RED preamps series!

- Built in 48volt phantom powering.
- Mic/Line input switch optimises the gain structure.
- Inputs via XLR/Jack combo socket
- Low Cut Switch filters out unwanted sub sonic frequencies
- Phase Reversal switch counters problems with incorrectly phased mics
- 8 band LED ladder indicates incoming signal level enabling the operator to optimise system performance
- Gain range 0-50dB. Response 20Hz - 20kHz.
- Signal/noise ratio better than 100dB

Description	Code	Price (Ex VAT)
RED 520	348-230	£41.20

OUTBOARD

Other Preamplifiers

Art Headamp

Stereo Headphone Amplifier

Adds additional headphone outputs to equipment without creating any additional load on the existing headphone source.

- 1x 1/4" stereo jack input
- 4x 1/4" stereo jack headphone outputs
- Output impedance of 51(omega)
- Maximum input level is +14dBV signal-to-noise of 90dB, distortion below 0.01 percent.
- Mains adaptor included



Description	Code	Price (Ex VAT)
Headamp	325-010	£39.17

Art DeeJay Pre II

Mixer Preamplifier

Corrects the output of record cartridges so that they can be fed into any stereo or mono sound system.

- Meets the RIAA equalisation requirements
- Inputs are on Phonos, outputs are Phonos and Jacks.
- Separate ground terminal for the earth of the deck
- Powering by 12V DC from the supplied adaptor



Description	Code	Price (Ex VAT)
DeeJay Pre II	325-000	£32.20

Studiospares Mono Valve

Microphone Preamplifier

The first step in re-creating the warmth of the sounds of yesteryear...

Valves have large voltage swings so can easily handle audio voltages without distortion or overloading. Based on two low noise 12AX7 valves, the first of which raises the signal level to a point where the 100Hz Low, 2.5kHz Mid and 10kHz High equalisers can correct any room or microphone tonal deficiencies. The following valve matches the preamp's output impedance to a low impedance which will drive any input of any equipment. Maximum output level +28dBm. Gain is adjustable from zero to +55dB. No transformers are used in the signal path so distortion is at a very low level. 48volt phantom powering can be switched on-off. This is an interesting product which is well built and really looks great. Input impedance 100kΩ (3.4kΩ with phantom power switched ON).



This Studiospares Mono Valve Microphone Preamp comes at a fraction of the price of competitive products.

Description	Code	Price (Ex VAT)
Mono Valve	348-000	£62.50



VISIT
our trade counter

You'll get friendly advice and immediate access to 8000+ product lines!

free parking for 40 cars

OUTBOARD

Other Preamplifiers

CONTINUED

B-Tech BT26

Phono/Microphone Preamplifier

A low noise high gain pre-amplifier for use with turntables' magnetic cartridges, or dynamic/condenser microphones.

- Suitable for a stereo mic or two mono mics
- Input switch for selecting mics or phono input
- Unbalanced RCA phono line ins/outs
- Unbalanced 1/4" mono jack mic ins
- All metal casing for improved shielding
- Power supply included



Description	Code	Price (Ex VAT)
BT26	426-350	£20.82

OUTBOARD

Receivers

TEAC AG-790

Stereo Receiver



A stereo receiver and power amplifier ideal for any situation.

- Delivers a strong 90 watts + 90 watts power at 8 ohms to two speakers
- 5 audio inputs including phono, CD, tuner and tape
- Includes a large FL display screen, a gold-plated headphone jack and a remote control unit
- Tone and balance control, A/B speaker selection and 30-station memory

Description	Code	Price (Ex VAT)
AG-790	223-020	£132.50

OUTBOARD

Power Amplifiers

Samson Servo series
Power Amplifiers

The Servo series has been a stalwart of studio monitoring systems for many years offering efficient, clear and reliable power for monitor speakers.

All power ratings are RMS at 4Ω impedance unless otherwise stated. The Servo amp line also feature a 4-stage power protection circuitry that ensures optimal performance and protection of connected components.

Samson Servo 120A

The newest servo amplifier is a 1U rack mount and is rated at 60W per channel at 4 ohms.

Samson Servo 200

Ideal for powering small to medium sized speaker chains, as well as playback and studio monitors. 100W per side. 200 watts bridged mono at 8 ohms.

Samson Servo 300

Essentially a 200 with a similar performance for midfield monitors and situations where more power is required. 130W per channel.

Samson Servo 600

For midfield monitoring the 600 offers 275W per channel or it can be bridged and a pair used for far field monitoring offering 600W.

Description	Code	Price (Ex VAT)
Servo 120A	388-040	£140.82
Servo 200	388-490	£140.82
Servo 300	388-060	£157.50
Servo 600	388-070	£216.66

SAMSON

PRICE

changes

This catalogue was priced on 1st December 2014.

Current prices may be higher...

see our website for up to date prices.

FREE

catalogue

Are you reading someone else's catalogue?
Why not call us and order your own copy...

it's free!

Behringer Europower EPX2800

Power Amplifier

NEW
LOWER
PRICE

The Behringer Europower EPX2800 gives out an ultra light and an ultra low noise. It features an ultra efficient switch mode power supply for noise free audio, superior transient response and low power consumption. Professional light weight stereo power amplifier with ATR (Accelerated Transient Response) Technology. With switchable limiters that offer maximum output level with reliable overload protection. Along with built in subwoofer/satellite crossover for more flexibility, this amplifier also features XLR, 1/4" TRS and RCA input connectors for compatibility with any source. Its high quality components and exceptionally rugged construction ensure prolonged durability.

Model	into 2Ω	into 4Ω	into 4Ω Bridged
EPX2800	2 x 1400W RMS	2 x 800W RMS	2800W RMS
Description	Code	Price (Ex VAT)	
EPX2800	382-990	£157.50	

WANT

a job?

Are you looking for a stable and rewarding career?

Studiospares are constantly expanding. We require additional staff for a variety of positions, working in a very congenial atmosphere. Practical experience of recording and/or live sound engineering would be preferable.

send in your CV in the first instance

1000s

of products

Available from stock!

Yamaha P Series

Power Amplifiers



This version incorporates a new higher efficiency power supply called the EEE (Energy Efficient Engine). Increased efficiency means less heat generated and greater reliability. Recently upgraded to be only 2U high and lighter, with both channels driven the output per channel into a 4Ω load is P2500S 390W, P3500S 590W, P5000S 750W and P7000S 1100W. Into an 8Ω load the figures are P2500S 275W, P3500S 390W, P5000S 525W, and P7000S 750W. They will power a 2Ω load with a slight increase in output power. Provision is made for bridging by activating a rear mounted switch. Slew rate figures are amongst the best at a maximum of +30V usec into an 8Ω load. Inputs via XLR type connectors and 1/4" Jacks. Outputs are Speakon, 5 way binding post, and 1/4" mono Jack. Probably the most popular and reliable amplifiers on the market over the last couple of years.

Description	Code	Price (Ex VAT)
P2500S	264-820	£265.00
P3500S	264-830	£349.17
P5000S	264-840	£365.00
P7000S	264-850	£486.67



Yamaha's P series amps are stable under all conditions.

As with all Yamaha products the build quality is excellent and the failure rate practically zero.

Denon DN-A300M

Power Amplifier



Offers a high quality solution for small installations, and provides increased amp power over the existing model range.

- 2 x 100W power amplifiers
- A/B speaker on/off buttons
- 6 unbalanced RCA audio inputs
- 2 unbalanced record outputs and 1 unbalanced pre-out
- 3U Rack kit and IR remote included
- 3 back-panel mounted AC inlets for powering additional equipment

Description	Code	Price (Ex VAT)
DN-A300M	271-640	£245.00

Denon DN-A100

Pro Amplifier



The DN-A100P is the P Series' entry level amplifier for commercial installation.

- Uncomplicated layout and simple operation
- 70W RMS per channel at 4Ω
- 2 speaker circuits with A/B switching
- 5 line inputs and 2 tape circuits (in/out)
- Remote control included

Description	Code	Price (Ex VAT)
DN-A100	271-430	£169.00

Crown XTI Series

Power Amplifiers



One of the most powerful and innovative amplifiers on the market today.

- Peakx Plus™ Limiters provide the ultimate in system performance
- Enhanced Subharmonic Synth section
- 3 User-defined fan mode controls – normal, early and fullspeed

Model	into 2Ω	into 4Ω	into 8Ω
1002	700W RMS	500W RMS	275W RMS
2002	1000W RMS	800W RMS	475W RMS
4002	1600W RMS	1200W RMS	650W RMS
6002	3000W RMS	2100W RMS	1200W RMS

Description	Code	Price (Ex VAT)
1002	243-140	£415.83
2002	243-150	£615.00
4002	243-160	£832.50
6002	243-170	£1540.00

Inter M PA-935 100V

Line Amplifier



A highly practical medium power mono amplifier that delivers 35 watts RMS, equally at home with 4Ω or 100V line systems.

- Three inputs: Mic 1. Mic2/Aux. Mic3/CD/Satellite
- Telephone Input.
- Mic 2/Aux and Mic 3/CD/Satellite are individually selectable
- Separate bass and treble controls to tailor your sound

Description	Code	Price (Ex VAT)
PA-935	427-660	£95.00

Stageline STA-1508

8-Channel 1800W Pro Amplifier



Multi-channel PA amplifier with integrated limiter.

- Balanced inputs
- Power: Stereo 4Ω - 8 x 160W RMS; Stereo 8Ω - 8 x 100W RMS; 8Ω bridged - 4 x 320W RMS
- High and low-pass filter and Tamper-resistant level adjustment
- Soft start and fan cooling

Description	Code	Price (Ex VAT)
STA-1508	255-770	£275.00

VISIT
our trade counter

You'll get friendly advice and immediate access to 8000+ product lines!

OUTBOARD

Power Amplifiers

CONTINUED

Behringer Europower

Power Amplifiers



Meet the needs of professional musicians for both installed applications or on the road...

The EP2000 and EP4000 represent everything musicians loved about the popular EP1500/EP2500—excellent sound quality, road-worthy toughness and reliability, low-noise operation and incredible power. With 2,000 and 4,000-Watts peak respectively, the EP2000 and EP4000 amplifiers are perfect for medium-sized club gigs, mobile PA systems, church services or public spaces. No corners were cut in the design process. XLR and 1/4" TRS input connectors for compatibility with any source. Independent limiters per channel offer reliable protection against overload and distortion.

Model	into 2Ω	into 4Ω	into 4Ω bridged
EP2000	2 x 650W RMS	2 x 600W RMS	1400W RMS
EP4000	2 x 1250W RMS	2 x 905W RMS	2400W RMS

Description	Code	Price (Ex VAT)
EP2000	382-010	£157.50
EP4000	382-000	£204.17

Inter M QD

4 Channel Amplifiers



With the necessity to drive more speakers in 5:1 systems or multi zone applications, a four channel power amplifier is a useful piece of equipment. Like all of the Inter M equipment the build quality is excellent and the sound quality bears comparison with any amplifier, whatever the price. It is very versatile being able to be operated in parallel, stereo or bridged modes. LEDs indicate the presence of signal on that channel. Clip when clipping occurs and Protect when the channel has shut down through being overdriven or a fault condition exists.

Model	into 4Ω	into 8Ω	Weight
QD4240	4 x 60W RMS	4 x 40W RMS	12kg
QD4480	4 x 120W RMS	4 x 80W RMS	15kg
QD4960	4 x 240W RMS	4 x 120W RMS	17kg

Description	Code	Price (Ex VAT)
QD4240	427-600	£229.00
QD4480	427-670	£362.50
QD4960	427-610	£442.55

1000s
of products
Available from stock!

Behringer iNuke Series

Power Amplifiers



The Behringer iNUKE power amplifiers pack massive amounts of output power into exceptionally lightweight, rack-mountable packages.

Model	into 2Ω	into 4Ω	into bridge 4Ω
NU1000	2 x 500W	2 x 300W	1000W
NU1000DSP	2 x 500W	2 x 300W	1000W
NU3000	2 x 1600W	2 x 900W	3000W
NU3000DSP	2 x 1600W	2 x 900W	3000W
NU6000	-	2 x 3000W	-
NU6000DSP	-	2 x 3000W	-
NU12000	2 x 6000W	2 x 3000W	-
NU12000DSP	2 x 6000W	2 x 3000W	-
NU4-6000	4 x 1600W	4 x 860W	2x 3000W

Description	Code	Price (Ex VAT)
NU1000	382-970	£107.50
NU1000DSP	382-960	£124.17
NU3000	382-950	£162.50
NU3000DSP	382-940	£212.50
NU6000	382-930	£215.83
NU6000DSP	382-920	£240.83
NU12000	384-330	£554.17
NU12000DSP	384-320	£624.17
NU4-6000	383-960	£282.50

The revolutionary high-density Class-D technology with "near-zero" thermal buildup combined with ultra-efficient switch-mode power supplies ensures these feather-light powerhouses will drive your rig effortlessly for many years to come. Built-in Subwoofer/Satellite crossover for perfect subwoofer operation. Ultra-efficient switch-mode power supply for noise-free audio, superior transient response and low power consumption.



Behringer EPQ Series

Power Amplifiers



Packs the power of Accelerated Transient Response (ATR) technology into an exceptionally lightweight package.

- 5 versions are available
- The simple front panel controls of these amps give you all of your sound's vital signs at a glance
- After pressing the power button, the POWER LED will light when the amp is ready for action
- Ideal for the working musician and built to last through the rigours of the road

Description	Code	Price (Ex VAT)
EPQ304 300 Watts	382-710	£149.17
EPQ450 460 Watts	382-720	£99.17
EPQ1000 1060 Watts	382-730	£115.83
EPQ1200 1200 Watts	382-740	£157.50
EPQ2000 2000 Watts	382-750	£182.50

Behringer A500

Power Amplifiers



The top choice for recording studios and post-production work, yet its amazing price is just the beginning.

- 2 x 300W into 4Ω, 600W into 8Ω in bridged mono operation
- Advanced convection-cooling, precise level meter and clip indicators
- Input on balanced XLR, 1/4" TRS and RCA connectors
- Ultra-reliable Toshiba / Fairchild power transistors

Description	Code	Price (Ex VAT)
A500	380-160	£115.83

MORE PRODUCTS
online

Studiospares Trojan Series

Power Amplifiers



The Trojan series has quickly gained a reputation for reliability and a solid performance covering a power range of between 200 and 900 watts. The new range Trojan Plus extends the power range to from 900 watts to 2.2 kilowatts with enough muscle to drive most speakers to a cinder. It features a plug in output stage which can be replaced by anyone handy with a screwdriver within minutes. The overall construction is more substantial and the circuitry more sophisticated. Both ranges share common features such as automatic protection against short circuits, overload, and overheating. System Status is provided by LEDs indicating signal present and power clipping. Quiet fans whose speed varies with the output stage's temperature keep the electronics at the right temperature. Aside from the 1U 200 watt model, all versions are 2U high. Studiospares amplifiers quote RMS power which is real power. Other manufacturers forget to quote which standard they use so can quote any wattage that enters their heads. Inputs are via combined XLRs and Jacks. Outputs are via Speaklocs which mate with any other twist to lock speaker plugs and binding posts. Judged by any standard these two models are quality products and represent outstanding value as much due to large scale production and Studiospares selling direct and not via the "middle man".

Combines solid engineering principles with the requirements of the serious power amplifier user.

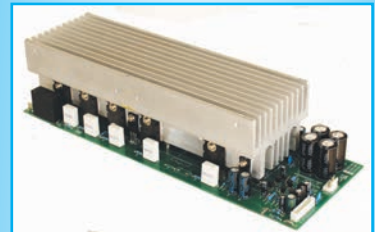

Trojan Plus Plug in Output stage



Trojan 900



Trojan 2200+



Model	into 4Ω	into 8Ω	into 8Ω bridged
Trojan 200	2 x 100W	2 x 60W	200W
Trojan 600	2 x 300W	2 x 150W	500W
Trojan 900	2 x 450W	2 x 230W	900W
Trojan 900+	2 x 450W	2 x 300W	900W
Trojan 1500+	2 x 750W	2 x 500W	1500W
Trojan 2200+	2 x 1100W	2 x 700W	2200W

The following specification is common to all models:

- Input sensitivity** Trojan Balanced 0.89V (-1dBV), Unbalanced 1.67V (4.5dBV)
Trojan Plus 1.4v Balanced/Un balanced
- Frequency Response** Trojan 5Hz - 20kHz +0dB - 1dB
Trojan Plus 20Hz - 20kHz ± 0.3dB
(A weighted below rated power) 100dB
(at full bandwidth power 20Hz - 20kHz) <0.03%
- Signal/Noise ratio** (4) >300
- THD** <0.03%
- Damping factor** (4) >300
- Load Impedance** Stereo mode 4 -8 per chan Bridge Mono 8
- Protection** DC, short circuit, thermal, overload and clip limiter
- Input connectors** XLR and Jack
- Output connectors** 3x Speakons
- Indicators** Signal LED, Clip LED, Power LED
- Cooling** Variable speed low noise fan
- Power requirements** 110 - 120V/60Hz and 220 - 240V/50Hz

Description	Code	Price (Ex VAT)
Trojan 200	348-100	£119.00
Trojan 600	348-110	£159.00
Trojan 900	348-120	£189.00
Trojan 900+	348-200	£225.00
Trojan 1500+	348-210	£265.00
Trojan 2200+	348-220	£308.00



OUTBOARD

Power Amplifiers

CONTINUED

Crown XLS Drivecore Series

Power Amplifiers



Efficient forced-air fans prevent excessive thermal build-up and LEDs indicate signal, clip and fault for each channel. The integrated crossovers and switch-mode power supply produce superior sound, and peak limiters protect the speakers. Crown's DriveCore technology drives the "front end" of the Class D output stage and prevents problems associated with fluctuating generator power or overloading by lighting rigs. Weighing less than 12 pounds, compared to 40 pounds for its competitors, it's much easier to set up and move from show to show.

Model	into 4Ω	into 8Ω	into 8Ω bridged
1000	2 x 350 watts RMS	2 x 215 watts RMS	700 watts RMS
1500	2 x 525 watts RMS	2 x 300 watts RMS	1050 watts RMS
2000	2 x 650 watts RMS	2 x 375 watts RMS	1300 watts RMS
2500	2 x 775 watts RMS	2 x 440 watts RMS	1550 watts RMS

Description	Code	Price (Ex VAT)
XLS1000	243-100	£274.17
XLS1500	243-110	£299.17
XLS2000	243-120	£395.83
XLS2500	243-130	£457.50



Popular power amplifier range which include XLR, 1/4", and RCA inputs, and touch proof binding post and Speakon outputs.



XLS1000

Crown's XLS Series amplifiers define the standard for portable PA systems with unmatched performance, technology and affordability.

Crown XLI Series

Power Amplifiers



Represents a new era in affordable, quality power amplification.

- All four models in the series are powerful, rugged and reliable
- Suited for musicians, DJs, and entertainers as well as houses of worship, discos, and pubs
- Electronically balanced RCA & XLR inputs; binding post and Speakon outputs.

Model	into 4Ω	into 8Ω	into 8Ω bridged
800	300W RMS	200W RMS	600W RMS
1500	450W RMS	330W RMS	900W RMS
2500	750W RMS	500W RMS	1500W RMS
3500	1350W RMS	1000W RMS	2700W RMS

Description	Code	Price (Ex VAT)
800	243-240	£204.17
1500	243-230	£245.00
2500	243-220	£374.17
3500	243-210	£665.00

Crown DCi 4-300

4-Channel Power Amplifier



A Crown exclusive that combines hundreds of parts into one chip the size of a your fingertip, resulting in more efficiencies and unsurpassed reliability.

- Popular with installers who need to "fit and forget"
- Output Power 2Ω=150 watts 4 and 8Ω 300 watts. 70 and 100Vrms 300 watts
- DCI Series channels are bridgeable – even in 100Vrms mode
- Maximum input level before clipping 26dBu
- Weight 9.2kg
- Drive either one or two speakers in low-Z mode, or hundreds of speakers in high-Z mode (70Vrms or 100Vrms).

Description	Code	Price (Ex VAT)
DCi 4-300	243-200	£1198.50

Art SLA-4

4-Channel Power Amplifier



A true four-channel amplifier in a single rack-space that can be switched easily from Multi-channel, Stereo and Bridged Mono Modes.

- 4 x 100W/Ch at 8Ω, 140W/Ch at 4Ω
- 2 x 200W/Ch at 16Ω, 280W/Ch at 8Ω (bridged)
- 2 x 100W/Ch at 8Ω and 1 x 280W at 8Ω (bridged)
- Toroidal transformer
- 1/4-inch TRS, and euroblock balanced inputs
- 10Hz to 40kHz frequency response

Description	Code	Price (Ex VAT)
SLA-4	325-490	£349.17

VISIT
our trade counter

You'll get friendly advice and immediate access to 8000+ product lines!

MORE PRODUCTS
online

Monacor PA-900

160W PA Mixing Amplifier



A 120W RMS (160 W max) mono Public Address mixing amplifier with 4Ω and 70 v and 100 volt line options.

- 4 balanced mic/line inputs
- Mic 1 with priority circuit and automatic talkover
- Additional connection for desktop microphone via screw terminal
- Mains operation or 24V emergency power operation

Description	Code	Price (Ex VAT)
PA-900	255-740	£149.00

OUTBOARD

Induction Loops

Monacor LA-200

Loop Amplifier Active



Constant current technology with dynamic compressor for setting up an inductive sound reproduction systems.

- Automatic talk-over
- Metal loss correction 0-(+3)dB/oct
- Phantom power
- Supplied with 19" rack mounting brackets

Monacor LR-200

Inductive Receiver

Receives audio signals in inductive sound reproduction systems. Any number of receivers can be operated within one induction loop.



- 3.5mm mono minijack connection
- Volume control
- Low cut switch
- Belt clip
- Power supply via 9V battery
- 63 x 100 x 29mm

Description	Code	Price (Ex VAT)
LA-200	255-630	£169.00
LR-300	255-640	£33.50

OUTBOARD
Crossovers

Behringer Ultradrive Pro DCX2496
Professional Loudspeaker Management System



NEW LOWER PRICE

Digital loudspeaker management system with impressive audio quality and a great feature list.

An indispensable tool for the precise set-up of multiple loudspeaker systems or arrays. Installation contractors and live-sound engineers will find it invaluable. Signals can be split in various ways to assure precise sound by using the optimal frequency range of each loudspeaker. 3 analogue inputs (one suitable for AES/EBU) and 6 analogue outputs, extreme dynamic range of 113dB. Precise dynamic EQs for level-dependent equalization and extremely musical parametric EQs, selectable for all inputs and outputs, and "Zero"-attack limiters on all output channels guarantee optimal signal and loudspeaker protection. This is not just a sleek design: with highpower 32-bit SHARC@-DSP and ultrahigh resolution CRYSTAL@/AKM@ A/D & D/A converters the Ultradrive Pro offers outstanding audio performance.

Description	Code	Price (Ex VAT)
DCX2496	370-330	£166.65



dbx 234s

2/3/4 Way Crossover



A dual channel crossover with all the features you would expect from a professional product.

- Ultra low-noise, rugged reliability
- Linkwitz-Riley 24dB per octave filters
- Independent output gain controls for level matching
- Output phase inversion
- 40 Hz low cut filter
- Optional mono summing of the low frequency (subwoofer) output
- High quality 1/4" TRS inputs and outputs

Description	Code	Price (Ex VAT)
234s	379-190	£165.83
234XS	379-200	£179.00

Behringer Super-X Pro CX2310

Crossover

NEW LOWER PRICE



High-precision active frequency Crossover enabling 2 or 3-way stereo or even 4-way mono operation.

- Linkwitz-Riley filters with 24 dB/octave
- Output Gain controls for all bands
- Limiter, mute and phase reverse on each output
- XLR connectors for all inputs and outputs
- Low cut filter on each input
- Adjustable time delay for phase alignment

Description	Code	Price (Ex VAT)
CX2310	370-010	£47.50

Behringer Super-X Pro CX3400

Crossover

NEW LOWER PRICE



A new, high-precision active frequency crossover enabling 2 or 3-way stereo or even 4-way mono operation.

- Enables you to delay the low-frequency bands up to 2 m/sec
- Adjustable crossover frequencies and an additional polarity button per output allow perfect runtime and phase problem compensation
- Special frequency knobs with 41 detents
- Each band features an integrated interactive gain control limiter

Description	Code	Price (Ex VAT)
CX3400	370-020	£77.50

Keep up to date with all the latest products and current prices on the new look **Studiospares** website!

Check out www.studiospares.com

DELIVERY BEFORE NOON
no problem

SATURDAY DELIVERY
no problem

DELIVERY BEFORE 10AM
no problem

ALL PRICES EXCLUSIVE OF VAT.

DJ Equipment	
DJ Packages	48
Turntables	48
Turntable Accessories	48
DJ Media Players	49
Mixers	50
DJ Effects	52
Cases	52
Stands	54
Headphones	54
Radiomics	56
Monitors	57
PA Speakers	57
Portable PA	58
Power Amplifiers	58
Lighting/Effects	58
Controllers	60
Audio Interfaces	62
Production Tools	63

DJ Packages

Numark CDMIXBT

DJ Package

An improved version on the iconic twin CD with built in mixer, but now featuring wireless bluetooth connectivity.

- Bluetooth/AUX/mic channel with EQ
- Anti-Shock buffered skip-protection
- LCD display for excellent visibility in different lighting environments
- Housed in a solid steel chassis for rugged, reliable performance
- Multifunction jog/shuttle wheels for search, scratch, and pitch bend



Description	Code	Price (Ex VAT)
CDMIXBT	277-580	£265.83

Turntables

Stanton T.62

Direct Drive Turntable

An easy to operate, direct drive turntable perfect for DJs of any style or experience level.

- Straight Tone Arm Improves Tracking for Scratching
- Includes Quality Stanton 500.v3 Cartridge Pre-mounted on Headshell
- 2 Playback Speeds (33 or 45 RPM)
- 2 Start/Stop Switches for Mix or Battle Setup
- Manual Pitch Control Fader
- Includes RCA Cables, Slip Mat, and Dust Cover



Description	Code	Price (Ex VAT)
T.62	287-270	£140.83

DELIVERY BEFORE NOON
no problem

Pioneer PLX-1000

DJ Turntable

Delivers operability and excellent sound quality demanded by DJs.

- User-friendly control layout
- High-torque direct drive system
- Excellent sound quality design gets the most from the sound quality of analogue vinyl
- Tempo control with variable width selectable from three levels
- Attachable / detachable power and audio cables



Description	Code	Price (Ex VAT)
PLX-1000	285-850	£499.17

Turntable Accessories

Record Cleaning Brush

Popular, inexpensive brush for brushing vinyl clean prior to playback.

- With carbon fibre bristles optimised to clear the grooves and neutralise antistatic



Description	Code	Price (Ex VAT)
Record Cleaning Brush	451-270	£5.25

Numark Groovetool

Turntable Cartridge

A high value, adjustable cartridge in a traditional headshell mount design.

- Headshell mount and cartridge with stylus
- Replaceable stylus
- Great sound, great tracking
- Standard that comes with Numark packages



Description	Code	Price (Ex VAT)
Groovetool	276-650	£13.32
Replacement Stylus Pair	276-660	£13.32

Stageline Plug in Headshell

Cartridge

Gives a clear view of the stylus position.

- Plug in headshell
- Clear view of stylus position
- Standard 4 pin plug with 4 push on coloured wires



Description	Code	Price (Ex VAT)
Headshell	451-310	£5.45

Stanton 505 v3 H4

Twin Pack Cartridges

The best budget-priced scratching cartridge available today.

- Ideal for scratching
- 2-coil spherical design with high output and bass response
- New industrial design
- High output & bass response



Description	Code	Price (Ex VAT)
505 v3 H4	287-370	£65.00

Numark CC-1

Cartridge

The CC-1 is Numark's most versatile cartridge, and the Scratch Perverts signature model.

- High output and superior tracking
- Circular diamond tip
- Highly versatile performance
- Skip resistance
- 20 to 22,000Hz Frequency Response
- Output 6mV



Description	Code	Price (Ex VAT)
CC-1	276-080	£49.99
CC-1 Replacement Stylus	276-200	£24.99

Stageline EN24

DJ Cartridge with a Diamond Stylus

Optimised for DJ applications, and provides the DJ with real solid bass and sizzling highs.

- Solid bass, sizzling high response
- Very Durable
- Great for scratching
- Replacement stylus also available



Description	Code	Price (Ex VAT)
EN24	451-290	£12.40
EN24S Replacement Stylus	451-300	£9.51

Ortofon Concorde Series

Cartridge

Ortofon Concorde Pro 5

- With spherical type stylus.



Ortofon Concorde DJs

- With spherical type stylus.



Ortofon Concorde Scratch

- With spherical type stylus.



Description	Code	Price (Ex VAT)
Pro 5	286-000	£56.52
Pro 5 Replacement Stylus	286-030	£25.22
DJS	286-010	£66.50
DJS Replacement Stylus	286-040	£34.50
Scratch	286-020	£75.00
Scratch Replacement Stylus	286-050	£38.04

Felt Slip Mat

Many DJs consider the slip rate of felt mats are ideal for the job.

- Felt mat
- Optimum slip rate



Description	Code	Price (Ex VAT)
Felt Slip Mat	451-280	£3.50

THE
website

Keep up to date with all the latest products and current prices on the Studiospares website!

check out www.studiospares.com

DJ Media Players

Numark CDN77 USB

Rackmounting USB Dual CD Player

The Numark CDN77 USB is a Dual USB and MP3 CD player designed for professional DJs.

USB drive support allows you to put your entire digital music library on a USB flash or hard drive and use it at a gig. If you're a DJ transitioning to using MP3 files, CDN77 USB is ideal for you because it allows you to still use your entire library of CDs or MP3 CDs. In addition, CDN77 USB comes loaded with features like Master Tempo, Scratching, Seamless Loop, Pitch Control, Reverse and Brake effects and an Auto-BPM counter, making CDN77 USB an affordably priced unit with premium features.



Numark

Description	Code	Price (Ex VAT)
CDN77 USB	277-400	£237.50

Gemini CDM-4000

Dual MP3/CD/USB Console

Provides easy-to-use track search and playback features across dual CD decks.

- Audio CD, CR-R and MP3-CD compatible
- USB input for USB storage devices
- Anti-shock using RAM buffer memory
- Large blue-backlit LCD display
- Three selectable jog modes: Scratch, Search & Pitch Bend
- 2-band EQ with Gain Control
- 1/4-inch & 1/8-inch headphone output



Description	Code	Price (Ex VAT)
CDM-4000	290-130	£207.50



Gemini CDJ-300

MP3/CD/USB Deck

Gives you everything you need to get the party started!

- Fully loaded, compact, and portable media player
- Control your tracks from CDs and USB memory devices
- Large 5" touch-sensitive jog wheels
- Search, Scratch and Pitch Bend
- Programmable Hot Cues, Loops, Brake, Reverse and Variable Pitch Control with Master Tempo
- Anti-Shock buffer memory included



Description	Code	Price (Ex VAT)
CDJ-300	290-030	£132.50

Gemini CDX-2250

Dual CD/MP3 Player

19-inch twin CD player suited to both mobile DJ's and permanent installations providing ease of use and affordability in one great package.

- Mountable directly into a rack in 2 separate components or as 1
- Built-in anti-shock system
- Search and pitch bend jog wheel modes
- Seamless loop and reloop function
- Balanced XLR outputs



Description	Code	Price (Ex VAT)
CDX-2250	289-890	£137.50

Numark MP103USB

CD MP3 Player

The MP103USB is a rack-mountable CD/MP3 player and designed for professional DJs and installations.



Thousands of songs can be loaded from a computer onto a USB flash or hard drive. The MP103USB's USB input allows you to put your entire digital music library on a USB flash or hard drive and perform with it at a gig. If you are a DJ transitioning to using MP3 files, the MP103USB is ideal because it allows you to still use your entire library of CDs or MP3 CDs while giving you more options for using digital media. A fully loaded, compact, and portable media player makes the CDJ-300 a must have for all serious home, mobile and club DJs. It comes loaded with features working DJs need like Master Tempo, Scratching, Seamless Loop, Pitch Control, Reverse and Brake effects and an Auto-BPM counter. The MP103USB is loaded with premium features but is still affordable for DJs of any level. Balanced XLR outputs mean you can connect to any system in seconds with professional results.

Description	Code	Price (Ex VAT)
MP103USB	277-430	£132.50

Numark

Stageline CD-292 USB/CD-112

Dual DJ CD Player

A range of professional DJ CD players with high quality audio components from Monacor, award winning German engineering.

- USB storage media can be connected directly (e.g. USB hard disk, USB flash drive)



CD-292 USB



CD-112TR5

Model	Description	Code
CD-292 USB	Dual CD and MP3 player, with USB 2.0 interface	256-580
CD-112	CD and MP3 player with USB interface and SD/MMC card slot	256-590
CD-112TR5	CD and MP3 player, with USB 2.0 interface, RS-232 interface, SD/MMC card slot and FM/AM tuner	256-600

Description	Code	Price (Ex VAT)
CD-292 USB	256-580	£224.17
CD-112	256-590	£199.00
CD-112TR5	256-600	£225.00

ALL PRICES EXCLUSIVE OF VAT.

DJ Media Players

CONTINUED

Pioneer CDJ2000 Nexus

DJ CD Player

Offers the incredible feel and performance of vinyl at your fingertips...

The CDJ-2000 Nexus features multi format playback which enables playback of MP3, AAC, WAV and AIFF audio files on CD, DVD-ROM, SD card and USB memory devices. It also features Pro DJ Link which is a new Pioneer Pro DJ Link that enables up to four CDJ-2000/900s to connect and share a single music source. This CD player is packed full of exciting features, it features a 6.1 inch full colour LCD panel and a graphic user interface so DJs can find information that is needed to select a song at a glance. Its needle search helps DJs instantaneously get to a specific part of a song with a simple touch of the needle search pad. MIDI users can assign various buttons of the CDJ-2000 Nexus to trigger other devices, such as DJ effectors and software with MIDI mapping capability. Free Rekordbox music management software is included. When music files are imported to Rekordbox, the software analyzes each file and prepares them for use specifically with the new CDJ turntables.



Description	Code	Price (Ex VAT)
CDJ2000 Nexus	285-750	£1249.00

Pioneer

Numark NDX200

DJ CD Player

A CD player with a heavy, rugged build and a large jog wheel for comfortable performance.

- Large jog wheel
- Buffered skip-protection technology
- Seamless looping for creating and integrating loops
- Single, continuous, and programmable playback modes



Numark NDX400

Tabletop Scratch USB/MP3/CD Player

An advanced, touch-activated scratch MP3/CD player that can also play from a USB flash drive.

- Auto BPM with tap override
- Start/stop-time adjustment
- Reverse mode for special effects
- Pitch tracks up or down by up to 100%
- Three fader start settings: Play/Cue, Lock, and Tact



Description	Code	Price (Ex VAT)
NDX200	277-020	£107.50
NDX400	277-190	£165.83

DJ Mixers

Newhank Workmate

2U 19" Compact Mixer Media Player

NEW



A complete stereo mixer/pre-amplifier and smart media player in a compact package.

- Compact 2u low noise audio design
- 4 Line control channels plus separate Mic section
- 2 stereo phono, 7 stereo Line and 3 Mic inputs
- 2-band equalizer per channel
- Stereo Master audio out on both RCA and balanced XLR
- Balanced stereo Booth output on 6.3MM connectors
- Select play from USB, SD (both max 32GB) and thru Bluetooth

Newhank Playmate

4U 19" Stereo Mixer Media Player

NEW



Professional 4HE 19" stereo rack mixer and media player.

- Select play from USB, SD (max 32GB) and Bluetooth
- Plays both WAV and MP3 files
- Compact 4u low noise audio design
- 4 Line control channels plus separate microphone section
- 2 phono/line, 6 stereo Line and 3 microphone inputs
- 3-band equalizer per channel (-30dB/+10dB)
- Replaceable assignable crossfader

Description	Code	Price (Ex VAT)
Workmate	232-020	£220.83
Playmate	232-030	£270.83

Newhank MP203USB

Dual CD/MP3/USB Player

NEW



The perfect solution for the playback of WAV and MP3 files from CD, CDR, CDRW and MP3 files from USB media.

- Pitch control with pitch bend, seamless looping and 40 seconds shock memory
- Slot in mechanisms with Sanyo Lasers
- +/- 12% pitch control and +/- 16% Pitch bend buttons
- ALPS pitch bend -search jog wheels
- Auto Cue and Seamless loop
- Wide angle large backlight LCD displays
- Smart push style rotary encoder
- Support both folders and ID3 tags, max 99 folders / 999 tracks / 16Gb
- MP103USB - Single CD version of MP203USB

Description	Code	Price (Ex VAT)
MP203USB	232-000	£345.00
MP103USB	232-010	£265.83

Gemini CDM-3250

Dual MP3/CD Player Mixer Console

Gemini's CDM-3250 CD Mixing Console is a powerful, cost-effective tool that provides easy-to-use track search and playback features across dual CD decks.

- 2 independent jog wheels
- Pitch Control slider for maximum beat-matching control
- Central mixer section with 2 band EQ and gain control
- An array of inputs and outputs



Description	Code	Price (Ex VAT)
CDM-3250	289-880	£165.83

Akai AMX

DJ Mixer Interface

NEW

A versatile 2-channel mixing surface from Akai Professional.

- Provides extensive hands-on mixing, transport, and Serato NoiseMap capability for Serato DJ
- 2 line faders with gain controls and tri-color LED metering
- 2 Phono/Line Inputs for Serato DJ Control Signal
- Pro-grade, adjustable mini innofADER™ crossfader with reverse switch
- 9 touch-activated knobs for groundbreaking EQ kills and Filter sweeps
- 3-band EQ per channel with dedicated filter knob



Description	Code	Price (Ex VAT)
AMX	266-040	£149.17

Allen & Heath Xone:92

Club DJ Mixer

The industry-standard Xone:92 defines the sound of superclubs, with features to suit all DJ styles from breakbeat to techno, trance to house.

- 6 dual stereo channels
- 4 phono/line,
- 2 mono/mic or stereo return
- MIDI output capability
- 2 independent VCF filters
- 2 stereo FX sends
- Ducking control on mono/mic channel



Description	Code	Price (Ex VAT)
Xone:92	269-420	£974.17

MORE PRODUCTS
online

DELIVERY BEFORE NOON
no problem

Allen & Heath Xone 23

DJ Mixer

Packed with pro features that would normally be found in the booth of a top-rated club.

- 2+2 channels with dual phono/line inputs
- VCF Filter system – low-pass + high-pass filters plus frequency and resonance controls
- 3-band true total kill EQ
- External FX loop
- Mic input on balanced XLR, with 2-band EQ
- Balanced main mix out on XLR
- Super smooth VCA channel faders



NEW

Description	Code	Price (Ex VAT)
Xone 23	269-630	£249.00

Allen & Heath Xone2:62/Xone2:464

Digital DJ FX Mixer

DJ Mixer range, allowing you to get fully creative with your mix.

- 6 dual stereo inputs
- VCF system – 2 independent stereo filters with frequency and resonance controls
- 4-band EQ with +6dB and -26dB cut
- Built for tough conditions
- The Xone2:62 has 2 mic/line inputs and the Xone2:464 has 4 VCA Cross Fader
- 2 state variable VCF synth style filters



Description	Code	Price (Ex VAT)
Xone2:62	269-430	£690.83
Xone2:464	269-410	£1057.50

Allen & Heath Xone 22

DJ Mixer

Offers the top quality audio and professional feature set usually only found in the booth of a top-rated club...

- 2 stereo channels with dual phono/line inputs
- Phono inputs can be configured to be line level
- VCF system offering low-pass and high-pass filters, frequency sweep and resonance controls
- 3 band full cut EQ
- Soft-switched, FET-controlled external effects loop



Allen & Heath Xone 42

DJ Mixer

The Xone 42 is a 4-channel version of the above. Incorporates professional grade features, such as a full cut isolator/EQ, accurate metering and high quality faders. Dedicated local monitor output.

Description	Code	Price (Ex VAT)
Xone 22	269-250	£207.50
Xone 42	269-260	£479.00

Behringer DJX900USB

DJ Mixer

Professional 5-Channel DJ Mixer with infinium "Contact-Free" VCA Crossfader, Advanced Digital Effects and USB/Audio Interface.

Professional 5-channel ultra-low noise DJ mixer with stylish, black design. 45-mm infinium "contact-free" optical crossfader with adjustable tension and fader curve for years of use. State-of-the-art 24-bit digital effects with advanced parameter control. Built-in USB interface for recording and playback of any digital music file. Works with your PC or Mac computer—no setup or drivers required. Intelligent dual auto-BPM counter with time and beat sync display. 3-band kill EQ and precise level meters with peak hold function per channel. Additional 3-way kill switches with extremely steep frequency separation. Awesome adjustable XPQ stereo surround effect. VCA-controlled faders for utmost reliability and noise-free performance. Adjustable crossfader curve for all mixing styles. Monitor function with master/cue balance control and split option. Auto-talkover function with separate depth control. High-quality components and exceptionally rugged construction ensure long life.

Description	Code	Price (Ex VAT)
DJX900USB	382-880	£140.83



NEW LOWER PRICE



Behringer DJX750

Professional DJ Mixer

Pro 5-Channel DJ mixer with advanced digital effects and dual auto-BPM Counter.

- Super-smooth ULTRAGLIDE faders
- Awesome adjustable XPQ stereo surround effect
- 3-band kill EQ (-32 dB) and precise level meters
- Monitor function with master/cue balance control and split option
- Auto-talkover function with separate depth control



NEW LOWER PRICE

Description	Code	Price (Ex VAT)
DJX750	381-830	£115.83

Behringer DX2000USB

Professional DJ Mixer

Professional, 7-channel, ultra-low noise DJ mixer with state-of-the-art phono preamps.

- Built-in USB interface for recording and playback of any digital music file
- Ultra-musical 3-band kill EQ (-32 dB) with EQ on/off switch on all stereo channels
- 100-mm faders and sealed rotary controls on all input channels
- Headphone output



NEW LOWER PRICE

Description	Code	Price (Ex VAT)
DX2000USB	382-790	£165.00

Behringer DDM4000

Digital DJ Mixer

Ultimate 5-Channel Digital DJ Mixer with Sampler, Dual BPM Counter and MIDI...

The popular DDM4000 is a state-of-the-art 32-bit digital DJ mixer, jam-packed with creative tools, yet its intuitive layout will let you feel at home in an instant. Editing, storing and recalling your settings is simply a breeze. Hook up your turntables and CD/MP3 players to its 4 stereo channels, each with fully programmable EQ and Kill switches. Put ultimate versatility at your fingertips with fully programmable beat-sync'able multi-FX modules, a pair of high-precision BPM counters and a digital crossfader with custom curve adjustment. Features BPM-sync'd sampler with real-time pitch control, loop and reverse functions.

Description	Code	Price (Ex VAT)
DDM4000	381-790	£207.50
DDM4000 Cross-Fader	383-520	£22.00



NEW LOWER PRICE



1000s
of products
Available from stock!

SATURDAY DELIVERY
no problem

DELIVERY BEFORE 10AM
no problem

ALL PRICES EXCLUSIVE OF VAT.

DJ Mixers

CONTINUED

Behringer NOX101

DJ Mixer

Premium 2-Channel DJ Mixer with Full VCA-Control and Ultraglide Crossfader.

- Fully VCA-controlled cross and channel faders for utmost reliability and noise-free audio
- Replaceable, long-life Ultraglide crossfader with up to 500,000 life cycles
- Direction-reverse and adjustable crossfader curve control
- Awesome 3-band EQs with kill filters
- 2 Phono/Line inputs with individual gain controls



Description	Code	Price (Ex VAT)
NOX101	384-340	£57.50

DJ Mixer Accessories

Behringer ULTRAGLIDE

Replacement Cross Faders

Module CFM-2

- Replacement Crossfader for VMX1000/ VMX300/ VMX200/ DJX700/DX052 (Only for 4-Pin Cable Connector)

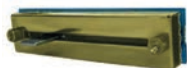

Module CFM-1

- Replacement Crossfader for DJX400 and DX626 (Only for 5-Pin Cable Connector)

Description	Code	Price (Ex VAT)
CFM-2	380-900	£9.52
CFM-1	380-910	£9.52

DJ Effects

Stageline VU-800/SW

Audio DB Display



A useful piece of kit for visually displaying sound levels. The 3-colour LED display with 40 LEDs can be switched to dot or bar graph display with a range of 45dB to +12dB. There is an Input level control for each channel. 19" rack mountable. Input, stereo1 x Phono L/R, Output, stereo1 x Phono L/R. Dimensions (WxHxD) 482x45x50mm

Description	Code	Price (Ex VAT)
VU-800/SW	255-760	£44.30

1000s
of products
Available from stock!

DJ Cases

Trojan Wheeled Case

Extremely useful 7 drawer roadie case with a lift off lid forming a desk or bench. 9mm plywood construction.

- 7x drawers mm3x 88 3x 132 1x 264.
- Ext 520mm wide x 525 deep x 967 high.
- 4 handles, 4 butterfly catches.
- Lift off lid/bench 967mm x 525mm.
- Laminated plastic covering.



TROJAN SERIES

Description	Code	Price (Ex VAT)
7-Drawer Case	458-540	£153.00

Trojan MC4U-12U

Table Top Mixer Case

Mixer series with the finest available fittings and a build quality second to none...

The sloping mixer part provides 12U of mixer space to accommodate the new mixers from Behringer, Mackie, Soundcraft and Yamaha. The case provides an additional 89mm (2U) of rack space to accommodate the depth of the mixer. A rear access door includes substantial hinges and catches. Distance between mixer and lid 20mm. There are two versions, 4U for table top operation with a handle either side and a 16U version which includes four handles and castors, two of which have brakes. Equipment mounting hardware is included. These cases come direct to you via Studiospares from one of the largest case manufacturers in the world. Cases are fully ROHS compliant. We guarantee these cases are of the highest quality, they have to be, they bear the Studiospares name!



TROJAN SERIES

Description	Code	Price (Ex VAT)
MC4U-12U	458-370	£72.50

Slappa CD/DVD Hard Cases



40 CDs 160 CDs 240 CDs 40 DVDs

Top quality Black/graphite cases with decent sized pockets, velvet lined interiors, and a disc cleaning cloth.

- Available in a variety of different sizes.

Description	Code	Price (Ex VAT)
CD Case 40 CDs	279-750	£13.29
CD Case 160 CDs	279-760	£31.50
CD Case 240 CDs	279-770	£36.50
CD Case 360 CDs	279-780	£39.30
DVD Case 40 DVDs	279-790	£26.90

Citronic 8U/16U

Wheeled Equipment Racks

Mobile Equipment Rack with facility to mount a 19" (10U) Mixer on top of the unit.

Front and top lid completely removable
Rear access panel.
Robust rack case and wheels are supplied.

Dimensions: 840 x 600 x 540mm.
Carrying capacity 250kg.



Description	Code	Price (Ex VAT)
8U Wheeled	475-150	£189.00
16U Wheeled	475-060	£212.50

MORE PRODUCTS
online

DELIVERY BEFORE 10AM
no problem

SATURDAY DELIVERY
no problem

Trojan AMC16U-12U

Popup Mixer Case With Legs

This version is a variant of the MC16U where the mixer can be set at any angle.

There is 12U of mixer space. Rear access is a hinged rear door. Front and rear covers form tables either side of the case. Table tops measure 900mm x 500mm and are 715mm from the ground.

The legs retract inside the lids and are held in place by Velcro straps for transportation purposes.

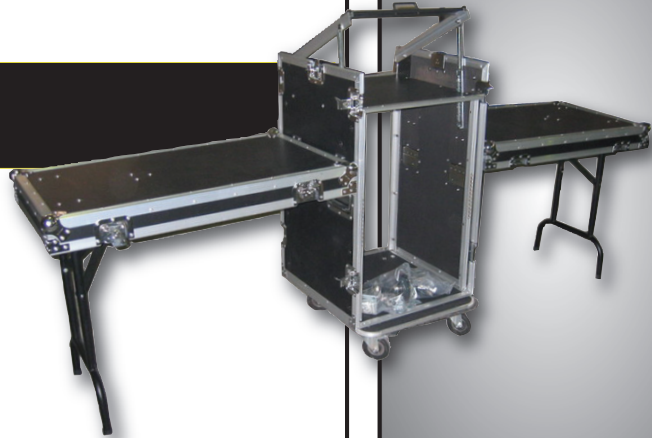

Description	Code	Price (Ex VAT)
AMC16U-12U	458-390	£179.00



Trojan AMC12U-12U

Wheeled Rack Case

NEW



A Heavy Duty Rack Case with 12U of racking and 12U of mixer space. Based on 9mm Eucalyptus plywood selected for strength and light weight. Aluminium strip between lids and case sexed to form a seal against debris and rain. Steel High Balls protect corners. Mixer section raises to an angle on ratchet bars. Industrial locking wheels and recessed side handles make transportation simple. Supplied in a heavy duty corrugated cardboard carton. Rackstrip front and rear. Supplied with caged nuts and bolts

Description	Code	Price (Ex VAT)
AMC12U-12U	458-740	£149.00

DELIVERY BEFORE NOON
no problem

Trojan AL3

Carry Case

Many roadies use these for anything that will fit inside, even for things that really do not fit inside!

Lighter and cheaper than the traditional wooden/aluminium cases. Effective seal against moisture and dust etc. Comfortable carrying handle. Locking catches. Internally lined. Dimensions internal 408mmW x 265mmD x 90mmH.



Trojan AL4

Carry Case

A really lightweight yet solid carrying case which backs up good looks with quality fittings. Edges have mating groove and lip to maintain rigidity and stop dust & debris entering. Polished chrome bumpers and handle with a matt aluminium frame. Internal dimensions: Case Internal 548mmW x 265mmH x 90mmD, Lid 55mmD.



Description	Code	Price (Ex VAT)
AL3	458-460	£16.60
AL3 + Picky Foam	458-465	£19.99
AL4	458-730	£32.90
AL4 + 2x Picky Foam	458-735	£39.90



Trojan DJ Table

Mobile Recording Equipment Bag

An ingenious design where everything locks together to form a substantial DJ working environment.

It includes a full width shelf and recessed castors. Can be dismantled within seconds to form an easily managed rollaround unit. Constructed to the high standards of all the Trojan products.

Collapsed - W900 x H965 x D75mm
Extended - W1485 x H965 x D515mm

Description	Code	Price (Ex VAT)
Trojan DJ Table	458-400	£115.00



DJ Cases

CONTINUED

Gator GDJ

DJ Case

The Gator GDJ series is a moulded PE slant top DJ console rack case.

- They are rotational moulded polyethylene cases.
- The cover is made from 420-Denier nylon
- They also feature heavy-duty rack rails
- Moulded-in carry handles



Model	Description	Code
GDJ8X2	8U + 2U; Rack depth 390mm	471-210
GDJ8X4	8U + 4U; Rack depth 390mm	471-220
GDJ10X6	10U + 6U; Rack depth 444mm	471-230

Description	Code	Price (Ex VAT)
GDJ8x2	471-210	£65.00
GDJ8x4	471-220	£74.17
GDJ10x6	471-230	£89.00

Studiospares Trojan 2U Twin Flip Case

Rack Case

Requested by engineers/performers wanting a case that folded down to 2U for transportation.



- Fabricated from 9mm Eucalyptus plywood for greatest strength
- Industrial round feet protect all surfaces. They are screwed into T Nuts and NOT to the plywood
- Butterfly catches pull aluminium extrusions tight together
- Aluminium extrusions sexed to create a seal against dirt and rain
- Steel High Balls to protect corners
- Includes caged nuts and bolts



Description	Code	Price (Ex VAT)
Twin Flip Rack Case	458-750	£82.50

DJ Stands

QTX Lighting Stands

Lightweight Lighting Stand With T-Bar

New lighting stands from Citronic!

A robust black aluminium lighting stand on a foldable tripod with lockable height adjustment and safety pins. Height 1.5m - 3.5m. Max weight 40kg. T-bar width 1.2m. Weight 3.2kg. Heavy duty version offers a beefed-up tripod and hence a max weight load of 50kg. Stand weight 4.7kg.



Description	Code	Price (Ex VAT)
Standard	475-660	£35.00
Heavy Duty	475-670	£52.00

Citronic Lighting Truss Stand

Lightweight Stand With Truss and T-Bar

A strong 3m light truss and 2 T-bars with specially strengthened assembly points to increase the maximum load. Can be completely disassembled and is lightweight at only 18kg and easy to erect. Height 1.5 - 3kg. Max weight load 60kg. Weight 16kg.

Description	Code	Price (Ex VAT)
Lighting Truss Stand	475-680	£93.75

WANT a job?

Are you looking for a stable and rewarding career?

Studiospares are constantly expanding. We require additional staff for a variety of positions, working in a very congenial atmosphere. Practical experience of recording and/or live sound engineering would be preferable.

send in your CV in the first instance

Studiospares Telescopic Stand

Monitor Stand

A substantial and well engineered stand designed to support studio monitors.

The 23cm x 23cm supporting surface has wide rubber strips to grip the monitor.

The height can be adjusted between 75cm - 130cm. A retained pin passes through the upper telescopic pole to protect the speaker from damage should the clutch adjustment mechanism not be properly tightened.

The base is triangular, each side is 440cm long.

Description	Code	Price (Ex VAT)
Telescopic Stand	448-870	£14.20
Telescopic Stand - 4 Pack	448-874	£48.40



DJ Headphones

Sennheiser HD25SP II

DJ Headphones

Similar to the HD25, The SP version weighs less and has a slightly lower SPL rating.

- Lightweight and comfortable
- 65 Ohm nominal impedance for universal compatibility
- Neodymium ferrous magnet systems and lightweight aluminium/copper voice
- High maximum sound pressure level
- Tough, detachable OFC cable
- Frequency response: 30-16000Hz



Description	Code	Price (Ex VAT)
HD25SP II	452-910	£82.50
Spare Lead 12836	453-170	£32.50

Sennheiser HD215 MKII

DJ Headphones

Both outstanding sound characteristics and excellent attenuation of ambient noise.

- Rotatable ear cup for one-ear listening
- Single-sided coiled cable makes them ideal for DJ monitoring
- Spatial sound image
- Outstanding wearing comfort
- Convenient protective pouch
- Extremely rugged



Description	Code	Price (Ex VAT)
HD215 MKII	454-250	£57.50

Sennheiser HD25SP II

DJ Headphones

Similar to the HD25, The SP version weighs less and has a slightly lower SPL rating.

- Lightweight and comfortable
- 65 Ohm nominal impedance for universal compatibility
- Neodymium ferrous magnet systems and lightweight aluminium/copper voice
- High maximum sound pressure level
- Tough, detachable OFC cable
- Frequency response: 30-16000Hz



Description	Code	Price (Ex VAT)
HD25SP II	452-910	£82.50
Spare Lead 12836	453-170	£32.50

ProGuard Custom Earplugs

Customised Personal Earplugs

The perfect solution for anyone concerned about hearing protection, with a choice of attenuation levels.

- Custom attenuating earplugs made for you
- Includes impression appointments and postage
- Acoustic filters maintain sound quality
- SNR protection level of 23dB or 25dB



Description	Code	Price (Ex VAT)
ProGuard	401-870	£102.50

SATURDAY DELIVERY no problem

DELIVERY BEFORE NOON no problem

Studiospares Accent

Studio Headphones

Closed-back headphones at a budget price!

Many situations demand good isolation between what goes on inside the headphone and what goes on outside. It's pointless performing in front of a microphone if it can also pick up the sound from your headphones. The Accent headphones have sealed drivers which virtually cut out sounds leaving or entering the earphone. Also, low frequencies do not cancel out so the low frequency performance is better. Their design is very similar to the Presence Studio Monitor. The sensitivity is 108dB and the impedance is 32Ω. 4m connecting lead. Mini Jack to quarter inch Jack adaptor included.

Description	Code	Price (Ex VAT)
Accent	448-740	£16.63
Accent - 10 Pack	448-741	£149.17



**10
PACK**

Sennheiser HD8 DJ

Closed DJ Headphones

Take control of the club with Sennheiser's top-of-the-line DJ model.

- Crafted from durable, high quality metal parts
- Features Sennheiser's excellent proprietary acoustics system
- Capable of very loud, high SPL
- Swiveling ear cups (up to 210°, both ear cups)
- Impedance 95Ω
- Single-sided coiled cable



NEW

Sennheiser HD6 MIX

DJ Headphones

Developed with studio-based music creation in mind.

- Constructed of rugged but lightweight parts
- Soft and durable ear cushions
- Proprietary acoustics system gives you an accurate and balanced sound
- Impedance 150Ω
- Frequency Response 8 - 30,000Hz
- Sound pressure level (SPL) 112 dB (1 kHz/1Vrms)



NEW

Sennheiser HD25

DJ Headphones

Compactly designed specifically for the professional user.

- For convenience one earphone can be swivelled sideways for single side only
- Frequency response 30Hz-16kHz
- Stainless steel plug-in cable
- Impedance 70Ω for compatibility with 8 1/2 headphone outputs
- Very high sensitivity



ENCLOSED DESIGN

Sennheiser HD7 DJ

Closed DJ Headphones

Designed with the working DJs in mind.

- Constructed of rugged but lightweight parts
- Elliptical, circumaural design
- Swiveling ear cups (up to 210°, both ear cups)
- Proprietary acoustics system gives you an accurate and balanced sound
- Impedance 95Ω
- Single-sided coiled cable



NEW

Description	Code	Price (Ex VAT)
HD6 MIX	473-790	£145.00

Description	Code	Price (Ex VAT)
HD25	452-540	£132.50
Spare Lead 40180	900-054	£35.65

Numark HF125

DJ Headphones

Quality DJ Headphones from one of the top names in DJ equipment.

- Flexible 7-position independently adjustable dual ear cups
- Large 40mm Mylar speaker drivers
- 6ft tangle-resistant cord with 1/4" jack plug
- Padded headband and ear cups
- Minijack plug and adapter not included

Description	Code	Price (Ex VAT)
HF125	276-000	£5.78
HF125 - Pack of 6	276-006	£31.20

**6
PACK**



ENCLOSED DESIGN

Numark

Sennheiser HD205

DJ Headphones

The HD205s provide an excellent sound quality and a brilliant shielding of ambient noise.

- Medium-sized dynamic, supra-aural headphones
- For compact systems or mobile players (32ohm)
- Outstanding passive attenuation of ambient noise
- Rotatable ear cup for one-ear listening
- Convenient protective pouch included
- 3.5 mm jack plug and 1/4" (6.3 mm) screw-on jack adaptor, gold-plated
- Single-sided cable



Description	Code	Price (Ex VAT)
HD205	454-280	£31.24

Behringer HPX2000

DJ Headphones

High-quality DJ headphones for demanding users in home and live applications.

- Ultra-high dynamic range
- High-efficiency cobalt capsule
- 1/8" connector plus 1/4" adapter
- Single-sided cord with oxygen-free copper wires
- Rotating, reversible round-shaped ear cups
- Ultra-rugged headband construction



NEW LOWER PRICE

Description	Code	Price (Ex VAT)
HPX2000	370-180	£12.50

FOR
fax orders
Use our fax number...
020 8450 4390

DELIVERY BEFORE 10AM
no problem

DJ Headphones

CONTINUED

Beyer DT231 Pro Headphones

The DT231 provides good sound isolation from a high ambient background noise at a modest price.

The DT231 is of a closed design with the added benefit of producing a more detailed bass response. Open designs simply miss out the bottom octave. Frequency range is 20Hz - 18kHz. The ear coupling and earpads are supraaural to maintain long term comfort without fatigue.

Impedance is 32 ohms and nominal SPL is 95dB. MiniJack plug with 1/4inch adaptor.

Description	Code	Price (Ex VAT)
DT231 Pro	410-860	£27.22



beyerdynamic)))

Extreme Isolation Ex-29B Headphones

Swiss made products tend to be well made and maintain their specification for years, the EX-29B phones are well thought-out.

For travel, they fold up neatly and into a small package. The sound is solid and tight. Nothing hyped – just sonically pleasurable and smooth. The imagery and spatial depth are superb. Extreme Isolation Headphones are quite comfortable considering the extreme design needed to deliver an impressive reduction of 29dB. An interesting experiment is to listen at a good level, and then take them off and push the two phone pads together. What is heard – even with the phones less than six inches away – is nothing.

This version now includes a cable mounted volume control. Impedance 32Ω.

Description	Code	Price (Ex VAT)
Ex-29B	401-500	£90.83



Samson Stage 5

3-in-1 VHF Radiomic System

NEW



With the Stage 5 Wireless System, you get incredible reception, crystal clear sound in a VHF system priced to bring the freedom of wireless to everyone. This system offers transmitters for every application, including handheld, headset and lavalier microphone styles. It's perfect for guitars too, just plug in with a Samson GC5 guitar cable. A great-sounding and incredibly affordable system, the SR5 VHF receiver offers variable squelch, six-segment LED RF level and audio level metering, front mounted antenna and XLR and 1/4" outputs. The ST5 belt-pack features 1/8" mini-jack input for all Stage Series mic transmitters and will operate flawlessly for 10 hours with one 9-Volt battery. Includes battery level meter.

Description	Code	Price (Ex VAT)
Stage 5	308-000	£74.17

KAM KWM1940

Dual Handheld UHF Radiomic System

The KWM1940 is a portable dual UHF wireless mic kit.

- 16 channel PLL preset system
- DIP switch channel selection
- Range up to 50m
- Individual balanced XLR audio outputs
- Unbalanced jack 'mix' audio output
- 6 frequencies between 863MHz - 865MHz



KAM KWM1932

Dual UHF Radiomic System

- Similar to KWM1940, but with one handheld and one body pack transmitter, headset mic, lavalier mic and connecting cables

Description	Code	Price (Ex VAT)
KWM1940	226-270	£132.50
KWM1932	226-260	£115.83

DJ Radiomics

Gemini UHF-116/216

Single/Dual Channel UHF PLL Wireless System

Designed to provide clear, natural sound in any environment over longer distances.

- 16 operating frequencies between 854 MHz and 864 MHz
- Phase Locked Loop (PLL) circuitry for increased reception
- RF and AF LED indicators for monitoring incoming signal strength
- Auto mute with squelch control and built-in noise reduction
- Standard (1/4" 6.3mm jack) output
- Microphone On/Off switch
- 216M includes two UHF-16 HHM unidirectional microphones and a dual channel UHF-116 receiver



Description	Code	Price (Ex VAT)
UHF-116M Handheld	289-480	£62.50
UHF-116HL Headset/Lavalier	289-490	£62.50
UHF-216M Dual Handheld	289-500	£99.00
UHF-216HL Dual Headset/Lavalier	289-510	£99.00

Gemini VHF-2001

Dual Channel VHF Wireless System

The perfect affordable wireless microphone for presentations, houses of worship, vocalists, DJ's musicians and public speaking venues.

- High quality dual channel VHF receiver with 100' range
- 4 different channels that are matched to 4 different frequencies
- Power and Channel LED indicators
- Auto mute and built in noise reduction
- ON/OFF power switch
- 2 Unidirectional, handheld dynamic microphones



Description	Code	Price (Ex VAT)
VHF-2001M 173.8 Dual Channel	289-440	£49.00
VHF-2001M 175 Dual Channel	289-445	£49.00
VHF-2001HL 173.8 Dual Channel	289-450	£49.00
VHF-2001HL 175 Dual Channel	289-455	£49.00
VHF-04BP Transmitter only	289-460	£19.95
VHF-04HHM Handheld mic only	289-470	£29.00

PDF catalogue

Want this catalogue on your phone or laptop?

The Studiospares catalogue is now available in PDF format.

visit www.studiospares.com/page/pdfcatalogue!

FREE catalogue

Are you reading someone else's catalogue? Why not call us and order your own copy...

it's free!

DJ Monitors

Tannoy Reveal 802/502/402

Studio Monitors

Studio monitor range delivering absolutely premium tonal clarity.

- 802: Custom 8" Woofer, 1" tweeter, active crossover filter, 100 watt bi-amp module, front-firing bass port
- 502: Similar to 802 but with 5" custom LF Woofer
- 402: Similar to 802 but with ¾" soft-tweeter and 4" custom LF Woofer



Description	Code	Price (Ex VAT)
Reveal 802 x1	412-550	£174.17
Reveal 502 x1	412-540	£108.33
Reveal 502 x2 + Pads	412-541	£226.00
Reveal 502 x2 + Stands	412-542	£235.00
Reveal 402 x1	412-530	£87.50
Reveal 402 x2 + Pads	412-531	£184.00
Reveal 402 x2 + Stands	412-532	£193.00

Akai RPM Series

Studio Monitors

Engineered for meticulous reproduction of even the most complex modern music.

Akai's RPM500 studio monitors provide the tools needed to mix with confidence. The fast Kevlar® cone provides lucid low-end agility, reproducing intricate bass patterns with ease. It's authoritative sound for the craft of music production. The RPM 500 has a 50-Watt 5¼-inch (133.3mm) woofer, 90-Watt distributed Class A/B amp and a frequency response from 50Hz to 30kHz. The RPM 500 has a 80-Watt 8-inch (203.2mm) woofer, 120-Watt distributed Class A/B amp and a frequency response from 38Hz to 30kHz.



Description	Code	Price (Ex VAT)
RPM500 x 1	266-010	£129.17
RPM800 x 1	266-020	£187.50

DJ PA Speakers

Mackie SRM450 V3

PA Speakers

The most widely used portable speakers ever!

The all-new SRM450s deliver the unparalleled ease-of-use, professional sound quality and indestructible portability that made SRM a live sound legend. Now packed with 1000W of power, the widest selection of truly useful sound-enhancing DSP and setup-friendly audio tools, SRM is ready for your high-output application. SRMs feature modern tools like application-specific speaker modes and an automatic feedback destroyer, each with a single-button interface that gets you optimized performance in just seconds. And with the integrated 2-channel mixer, you can easily mix multiple sources. Only SRMs deliver this level of power and sound quality in such an indestructible, portable package.



Mackie SRM450 Bundle

Fantastic PA Package. Includes SRM450, 2 x 10m XLR Leads, 2 PA metal speaker stands and a Tuff speaker stand bag.

Description	Code	Price (Ex VAT)
SRM450 V3 x1	262-710	£332.50
SRM450 V3 x2	262-712	£665.00
SRM450 V3 Bundle	262-715	£665.83

MACKIE®

Skytec Stage Monitor

150W

Special bass reflex monitor box for horizontal positioning on the stage.

- 2-way system with a 25cm (10") bass driver
- Heavy construction
- Metal handles and corner protectors
- Gold-plated screw terminals
- Max power:150W
- Frequency response: 35Hz - 20kHz



Description	Code	Price (Ex VAT)
Stage Monitor	282-320	£47.50

MORE PRODUCTS online

Mackie Thump

PA Speaker

Deliver deep low-end and real power in a lightweight design that is extremely portable.



Class-D Fast Recovery™ amplification pushes unmatched power to the high-frequency compression driver and bass-pounding high-output woofer. Plus, Mackie Active processing, including a precision crossover and driver time-alignment provides total optimization for maximum system efficiency. Versatile by design, Thump loudspeakers feature a user-adjustable 3-band EQ for tone control and, since they can be pole-mounted or used as a wedge, the Thump Series loudspeakers represent the best value available for a complete stage solution. Bundle includes stands, stand bag, and connecting leads.

Description	Code	Price (Ex VAT)
Thump 12 x 1	262-670	£220.83
Thump 12 Pair + Bundle	262-671	£457.50
Thump 15 x 1	262-680	£249.17
Thump 15 Pair + Bundle	262-681	£515.00
Thump 185 x1 Sub	262-690	£482.50

DELIVERY BEFORE 10AM no problem

ALL PRICES EXCLUSIVE OF VAT.

Check out more Studiospares great offers and end-of-line products at our store on...



DJ PA Speakers

CONTINUED

Live L12 Pair

12" PA Speakers

A new range of PA speakers incorporating the very latest in driver technology. Substantial Ferrite magnets with high temperature voice coils provide a massive amount of power.

- 12" Live L12 150 watts RMS (300 watts peak)
- A proven Piezo Tweeter maintains crisp high end frequencies
- Impedance 8U
- Frequency response 60Hz - 18kHz
- Jack inputs, reinforced corners and metal grille



Packs	Description	Code
PACK A	Live L12 Pair + 2x Speaker Stands	249-225
PACK B	Live L12 Pair + 2x Speaker Stands + Trojan 200 Power Amplifier	249-226
PACK C	Live L12 Pair + 2x Speaker Stands + Trojan 900 Power Amplifier	249-227

Live L15 Pair

15" PA Speakers

A new range of PA speakers incorporating the very latest in driver technology.

- 15" Live L15 200 watts RMS (400 watts peak)
- A proven Piezo Tweeter maintains crisp high end frequencies
- Impedance 8U
- Frequency response 60Hz - 18kHz
- Jack inputs, reinforced corners and metal grille



Packs	Description	Code
PACK A	Live L15 Pair + 2x Speaker Stands	249-235
PACK B	Live L15 Pair + 2x Speaker Stands + Trojan 600 Power Amplifier	249-236
PACK C	Live L15 Pair + 2x Speaker Stands + Trojan Plus 900 Power Amplifier	249-237

Description	Code	Price (Ex VAT)
Live L12 Pair	249-222	£74.16
Live L12 Pack A	249-225	£120.83
Live L12 Pack B	249-226	£237.50
Live L12 Pack C	249-227	£290.83
Live L15 Pair	249-232	£104.16
Live L15 Pack A	249-235	£149.16
Live L15 Pack B	249-236	£287.50
Live L15 Pack C	249-237	£332.50
Live Sub	249-260	£49.17

DJ Portable PA Systems

Gemini PLAY2GO

Mobile PA System

Makes any small event or venue needing a sound system simple to setup and tear down.

- Roll around by the retractable handle
- Runs 12 hours with rechargeable battery
- Play tracks wirelessly from a mobile phone or any bluetooth enabled device
- Two mic and RCA inputs
- Includes professional dynamic mic
- 50W, 8" woofer, 1" silk dome tweeter



Description	Code	Price (Ex VAT)
Play2Go	290-060	£140.83

DJ Power Amplifiers

Behringer Europower Power Amplifiers



Meet the needs of professional musicians for both installed applications or on the road...

The EP2000 and EP4000 represent everything musicians loved about the popular EP1500/EP2500—excellent sound quality, road-worthy toughness and reliability, low-noise operation and incredible power. With 2,000 and 4,000-Watts peak respectively, the EP2000 and EP4000 amplifiers are perfect for medium-sized club gigs, mobile PA systems, church services or public spaces. No corners were cut in the design process. XLR and 1/4" TRS input connectors for compatibility with any source. Independent limiters per channel offer reliable protection against overload and distortion.

Model	into 2Ω	into 4Ω	into 4Ω bridged
EP2000	2 x 650W RMS	2 x 500W RMS	1400W RMS
EP4000	2 x 1250W RMS	2 x 950W RMS	2400W RMS

Description	Code	Price (Ex VAT)
EP2000	382-010	£157.50
EP4000	382-000	£204.17

DJ Lighting + Effects

Skytronic Dual Rack Lighting Bar

Lighting Bar

This Dual Rack Lighting Bar features flexible gooseneck lamps on a 19" rack mounting.

- Adjustable light intensity
- Fitted lamp
- Mains adaptor is included



Description	Code	Price (Ex VAT)
Lighting Bar	475-820	£39.70
Spare Lamp 475820	475-830	£1.25

KAM LED Power Partybar

Lighting Bar

Incredibly powerful all-in-one LED lighting system.

- Compact and portable design
- Dynamic ready-to-go lighting for stage performance or parties
- Portable system of four LED par can lights
- LED control panel built into T-Bar Sound-to-Light / Auto / DMX / Colour mix
- Adjustable stand: 1.3m to 2.15m
- Power consumption: 55w
- Includes LED Power Partybar / lighting stand / foot controller / mains power lead / Power Partybar kit padded case / stand bag



Description	Code	Price (Ex VAT)
Partybar	226-430	£332.50

Film Sheet

610 x 530mm

High quality British made filter gel sheets for theatre lights, PAR cans, etc.

- Colour lasts longer than standard gels without fading
- Designed for high temperatures
- Longer lasting colour than standard gels



Description	Code	Price (Ex VAT)
Medium Red	451-700	£5.80
Mauve	451-710	£5.80
Night Blue	451-720	£5.80
Dark Yellow/Green	451-730	£5.80
Dark Green	451-740	£5.80

Keep up to date with all the latest products and current prices on the new look **Studiospares** website!

Check out www.studiospares.com

FREE catalogue

Are you reading someone else's catalogue? Why not call us and order your own copy... **it's free!**

DELIVERY BEFORE NOON no problem

LEDJ LED-64 Can

DJ Lighting

Featuring high intensity 10mm LEDs, this Par can outputs washes of colour that serve as stunning backgrounds for performances of all sizes.

- 83 x 10mm LEDs (R: 60, G: 60, B: 63)
- Beam angle: 25°
- DMX channels: 4
- Static colour, auto, sound active and master/slave modes
- 0-100% dimming and variable strobe via DMX
- Dipswitches
- 3-pin XLR in/out sockets
- Captive power connection



NEW

Description	Code	Price (Ex VAT)
LED-64 Black	479-000	£57.50
LED-64 Chrome	479-010	£57.50

LEDJ Performer 18 Quad

LED Par Cans

Features 4-in-1 LED engine and produces no multi-coloured shadowing thanks to its 18 x 8W quad coloured LEDs.

- 18 x 8W quad-colour LEDs
- Beam angle: 40°
- DMX channels: 4 or 8 selectable
- Static colour, colour change, fade, auto, sound active and master/slave modes
- Bracket allows for multiple rigging or floor standing applications
- 4 push button menu with LED display
- 3-Pin XLR in/out sockets
- Captive power connection
- Fan cooled



NEW

Description	Code	Price (Ex VAT)
Performer 18 Quad	479-030	£150.00

MORE PRODUCTS online

LEDJ Performer 36 RGB

LED Par Cans

A DMX-512 controllable, full RGB colour mixing Par Can made up of high efficiency LED's.

Featuring 36x 3W LEDs (R: 12, G: 12, B: 12), the Alu Performer Par punches out astonishing spots of colour that can serve as a stunning show for various applications from uplighting a large venue and lighting a stage for live performances. The unit can be operated in several modes, including DMX, static colour, colour change, fade, auto, sound active and master/slave. The built-in programs ensure outstanding light shows when linked together by 3-pin XLR cables (master/slave). The chassis is made from lightweight cast aluminium complete with twin hanging bracket for secure hanging and floor standing.



NEW

Description	Code	Price (Ex VAT)
Performer 36 RGB	479-020	£99.17



Behringer Eurolight LC2412

Digital DJ Mixer

Professional 24-channel DMX lighting console...

The EUROLIGHT LC2412 has 24 preset channels assignable to 512 DMX channels. 120 scenes are storable in 10 banks, and there is an integrated chaser with up to 650 steps featuring sync-to-bass beat plus a frequency-dependent sound-to-light function. Crossfade time is freely selectable, allowing for super-smooth scene fades, and there are two additional, multi-functional channels for special effects (e.g. fog machine, colour changer etc.). You get ultra-flexible fading functions for manual and automatic operation and intuitive solo and channel flash functions. The extremely effective preview function allows "hidden" memory and chaser checks—even during live performances. The LC2412 also features dimmer control via DMX or analogue output (0/+10V) plus a MIDI interface for cascading of two LC2412s (master/slave setup) and a PCMCIA card slot for storing up to 25 complete settings (PCMCIA card not supplied). For added comfort, there are illuminated display/controls and BNC lamp socket for easy operation in dark stage environments. The whole unit is extremely ruggedly constructed, and its steel casing ensures long life even under the most demanding conditions. A rackmounting kit for installation in standard 19" racks is included, and the LC2412 is of course manufactured under ISO9001 certified management system.



Description	Code	Price (Ex VAT)
LC2412	370-410	£127.50



Skytronic Blacklight

Fluorescent UV Light Box



Ultra-Violet blacklight fluorescent tube.

- Blacklight box
- Available in 2 lengths 450mm and 1200mm
- With chrome reflector.
- Complete with starter and UV tube
- On/Off switch and fixed mains lead

Description	Code	Price (Ex VAT)
15W Blacklight	475-210	£13.75
40W Blacklight	475-220	£27.50

QTX LED Twister III

DJ Lighting

Small yet bright enough to cover a large area.

- Ideal for mobile DJs and small parties
- Operates stand alone or via sound activated mode, creating a great effect especially when viewed through smoke
- 46 bright LEDs 16 Red 12 Green 18 Blue
- Sound activated and Auto mode
- Sensitivity and pattern speed control
- Includes mounting bracket



Description	Code	Price (Ex VAT)
Twister III	476-470	£32.90

QTX SL-36

Mini LED Par Light

A small LED wash which uses 60 high power 5mm LEDs in a combination of RGBW technology to give the best variation of colour wash.

- 60 x 5mm wide angle RGBW LEDs
- 4 auto colour changing modes
- 6 Channel DMX (R,G,B,W, Master dimmer, Strobe & Sound-to-light mode)
- Sound-to-light colour changing, strobe and blinder strobe effect
- 10 preset colour options RGBW mixing
- With two dual mounting brackets for array format, floor standing or T-Bar mounting



Description	Code	Price (Ex VAT)
SL-36	476-480	£41.50

1000s of products Available from stock!

DELIVERY BEFORE 10AM no problem

SATURDAY DELIVERY no problem

DJ Lighting

CONTINUED

LEDJ Slimline 5Q5 RGBW

DJ LED

The Slimline 5Q5 give smooth colour mixing from rich saturated hues to subtle pastel shades.

- 5 x 5W quad-colour LEDs (RGBW)
- Beam angle: 25°
- 400Hz refresh rate
- 0 - 100% dimming with variable strobe
- DMX channels: 2/3/4 or 7 selectable
- Static colour, colour change, colour fade, auto run, sound active and master/slave amodes
- 4 push button menu with LED display
- Optional IR remote (LEDJ90C)
- 3-pin XLR in/out sockets
- IEC Power in/out sockets
- Bracket allows for multiple rigging and floor standing applications



NEW

Description	Code	Price (Ex VAT)
5Q5 Black	479-040	£57.50
5Q5 White	479-045	£57.50

LEDJ Slimline 1T-36 COB

DJ LED

COB LEDs with rugged, all metal housing, side entry XLR and power connections

- 1 x 36W tri-colour COB LED
- Interchangeable beam angle: 25° or 100°
- 1100Hz refresh rate
- 0 - 100% dimming with variable strobe
- DMX channels: 3 or 5 selectable
- Static colour, colour change, colour fade, auto run, sound active and master/slave modes
- 4 push button menu with LED display
- 3-pin XLR in/out sockets
- IEC Power in/out sockets
- Convection cooled
- Bracket allows for multiple rigging and floor standing applications



NEW

Description	Code	Price (Ex VAT)
1T-36 COB Black	479-050	£74.17
1T-36 COB White	479-055	£74.17

LEDJ LED Table Starcloth

Table Cloth System

Great for all mobile set-ups, hides all your wiring and adds a professional image to your set-up.

- Simply attach the Velcro loops and you have a great visual effect
- Table: 32 x 5mm white LEDs
- System includes: one LED Curtain, heavy duty carry bag and controller
- Hanging tabs on 3 sides
- Fire retardant material
- Controller: All on, sound active and chase modes



NEW

Description	Code	Price (Ex VAT)
LED Table Cloth Blue	479-080	£104.17
LED Table Cloth White	479-090	£104.17

Skytronic Moon

DJ Lighting Effect

Very colourful, compact mini Moon Flower light effect.

- Optical mirror rotates at 360°
- Sound activated via internal microphone
- Rotary sensitivity control.
- Adjustable mounting bracket
- Unbranded lamp supplied BRL - 12V, 50W



Description	Code	Price (Ex VAT)
Moon	475-280	£25.20

DJ Controllers

Gemini G2V/G4V

USB MIDI Controller

Transforms the standard DJ MIDI device into a dynamic and formidable software performance controller.

- 2 full-featured physical DJ decks
- On-the-fly loop move, and auto loop and loop roll modes. Mic and auxiliary inputs
- Gain, EQ, and Filter controls
- Balanced XLR master output, master and booth RCA outs
- Built for continually demanding use



Description	Code	Price (Ex VAT)
G2V 2 Channel mixer	290-040	£215.83
G4V 4 Channel mixer	290-050	£290.83

LEDJ HBR 1D Controller

DJ Controller

6 Channel DJ Controller designed for use with the LEDJ range.

This 6 channel controller from LEDJ is designed for the LEDJ Stage Colour 24 Tri, LEDJ Pixel Bar and Pixel Blox and LEDJ Colour Storm RGB and Tri. With its 7 preset colour, 6 function and 9 flow selection buttons, the HBR 1D is very easy to operate when specific colours of washes and chases are needed at the press of a button, as well as having the ability to spectrum mix any colour combination via the RGB sliders. Also included is 0-100% dimming, blackout, strobe and sound input via built-in microphone. The HBR 1D can be used in conjunction with the LEDJ MB 2 Foot controller, LEDJ124, (available separately) to offer increased flexibility for your performance.



NEW

LEDJ Lil' Mix

DJ Controller

The Lil Mix is the control centre for LEDJ products which have 4 channels.

This easy to use controller is equipped with a user friendly control panel which allows easy management of one touch colour selection buttons as well as the ability to spectrum mix any colour combination. Also included are pre-programmed chases, 0-100% dimming, blackout and a sound input via a built-in mic to bring any venue to life.



NEW

Description	Code	Price (Ex VAT)
HBR 1D	479-070	£70.83
Lil' Mix	479-060	£54.17



Check out more Studiospares great offers and end-of-line products at our store on...



Novation Launchpad S

DJ Controller

A powerful 64-button music controller that lets you make music or mix tracks using a super-intuitive grid of multi-colour buttons.



Launchpad S comes with Ableton Live music software (Launchpad Edition), used by some of the world's top DJs and producers – plus it supports other grid-based music applications such as FL Studio. Whether you're a DJ, performing musician or studio producer, Launchpad gives you all you need to 'play' your software straight out of the box. Use the 64-button grid to launch and manipulate clips, trigger loops, fire off effects, control your mixer – and much more. Launchpad S also triggers loops and effects in the new Novation Launchpad app for iPad: a totally self-standing music performance app that hosts sounds and effects. Launchpad is totally portable. Hooked up to your computer – or iPad – via USB, it's fully bus powered (no need for power sockets), and it's lightweight and easy to carry anywhere.

Novation Launchpad S Control Pack

Launchpad S Control Pack is a combination of everything you need to make and perform electronic music with Ableton Live, containing Launchpad S, Launch Control, two custom made protective sleeves, Ableton Live Lite 9, and a large pack of inspiring Loopmasters samples.

Description	Code	Price (Ex VAT)
Launchpad S	389-410	£107.50
Launchpad S Control Pack	389-460	£165.83



Novation Launch Control XL

DJ Controller

The ultimate controller for Ableton Live.

- Tweak your sound using 24 knobs with multicoloured indicators
- Enhance your live performance by combining with Launchpad S
- Get precise control over your levels with eight rugged faders
- Plug straight into Mac, PC or iPad and start performing
- 16 buttons for immediate track focus and key mixer controls
- Includes Ableton Live Lite software and Loopmasters sample collection



Description	Code	Price (Ex VAT)
Launch Control XL	389-470	£133.32

Pioneer DDJ-SX

Serato DJ Controller

World's first native controller for Serato DJ Serato DJ professional software included.

- NEW Performance Pads and Dual Deck Control
- Multiple loop options, Slicer, Slip Mode
- NEW FX Powered by iZotope
- 8 cue points, 6 samples
- Sound card inside. MIDI compatible



Description	Code	Price (Ex VAT)
DDJ-SX	285-840	£674.17

Pioneer DDJ Ergo

DJ Controller



Includes TRAKTOR LE 2 DJ software. When used with the TRAKTOR PRO 2 (fees apply), the controller can also operate as a 4-deck controller and sampler.

- LAPTOP DOCK construction enabling it to be positioned on a slant
- Completely USB-powered
- Channel fader knobs and crossfader knob are equipped with P-LOCK FADER cap. Built-in audio interface

Description	Code	Price (Ex VAT)
DDJ-Ergo-V	285-810	£316.00
DDJ-Ergo-K	285-820	£358.00

Akai MPD26

USB MIDI Controller

A MIDI-over-USB pad controller with genuine MPC pads, perfect for producers, programmers, musicians and DJs.

- 16 velocity and pressure-sensitive MPC pads
- Assignable Q-Link controllers
- Transport controls for instant access to DAW



Description	Code	Price (Ex VAT)
MPD26	265-700	£132.50

Akai AFX

DJ Controller

Controller for Advanced Serato DJ Performance.

- Provides extensive hands-on audio command of Serato DJ
- Tweak effects, manage loops, trigger samples, set cue points, and more
- Serato Flip-capable
- 4 decks of Serato DJ control over a single USB connection
- 9 touch-activated knobs for groundbreaking effects tweaking and EQ kills
- 8 velocity-sensitive trigger pads with backlit RGB feedback
- 10 pad modes for hot cues, loops, slicing, and sample triggering



Description	Code	Price (Ex VAT)
AFX	266-030	£115.83

Numark DJ2GO

Portable USB DJ Controller



An ultra-portable USB DJ Controller with two virtual decks.

- A/B Deck and crossfader for simple operation
- Mouseless navigation
- USB bus powered
- Compatible with virtually any MIDI DJ software
- Includes VirtualDJ LE Lite Software

Description	Code	Price (Ex VAT)
DJ2GO	277-320	£39.17

Numark Mixtrack Pro

DJ Controller

Mixtrack Pro is a complete DJ system that works with the music on your Mac or PC.

- Classic two-turntables-and-a-mixer setup
- Large, touch-sensitive turntables for accurate scratching and beat-juggling
- Houses a complete audio interface for top-quality sound



Description	Code	Price (Ex VAT)
Mixtrack Pro	277-510	£132.50



FOR
fax orders
Use our fax number...
020 8450 4390

VISIT
our trade counter
You'll get friendly advice and immediate access to 8000+ product lines!

1000s
of products
Available from stock!

MORE PRODUCTS
online

DJ Controllers

CONTINUED

Behringer B-Control DeeJay BCD3000

DJ Mixer

Lets you play, mix and scratch any MP3, WAV or other audio format with a real vinyl feel.

With features such as mixer, dual-player, effects, Mic/Phone preamps and a full-fledged monitor section, this 4-channel USB audio interface perfectly complements the included Native Instruments Traktor 3 LE DJ software or most other DJ software, running on Windows XP and Mac OS X operating systems. Features include: 24-bit converters and ultra-low latency operation, total performance control through 3-band kill EQ, loop buttons, pitch and level faders per channel plus an ultra-smooth crossfader, Internal microphone preamp with dedicated Level and EQ controls for MC performances or DJ's talkover, Dedicated control elements for play, cue, loop, pitch bend, search and effects.



Description	Code	Price (Ex VAT)
BCD3000	381-640	£82.50



Numark NV

Dual Display Controller

Intelligent dual-display controller for Serato DJ.

- 4 decks of cutting-edge Serato DJ control
- 10 pad modes for triggering samples, cues, loops, and slicing
- 2 dual-zone wheels with adaptive touch technology
- Full-colour, 1:1 real-time visualization of Serato DJ software
- Intelligent, touch-activated EQ, filter and effects knobs
- Includes Toolroom Records Remix Packs



NEW

Description	Code	Price (Ex VAT)
NV	277-610	£465.83

Stanton DJC-4

DJ MIDI Controller

Stanton's new DJC.4 is a complete solution for today's digital DJ, bundled with an enhanced 4-deck version of Virtual DJ LE.

- Allows users to scratch and mix 4 decks of audio, as well as control video
- Integrated 4-channel audio interface for integrating analogue turntables or CD decks
- Large touch sensitive jog wheels
- 95 assignable MIDI controllers



Description	Code	Price (Ex VAT)
DJC-4	287-350	£249.99

Gemini Slate DJ

USB MIDI Controller

USB/MIDI software controller with built-in professional 24-bit PC/MAC audio interface.

- Tools including pitch fader, key-lock, and effect controls.
- 2-channel mixer with 3-band EQ and dedicated Filter controls
- Pre-mapped FX controls for Serato DJ Intro
- 8 multi-function RGB pads per deck
- High Resolution touch-sensitive jog wheels
- Responsive controls with high-resolution 14-bit MIDI
- Midi mapping functionality over the entire controller
- 1/4" mic input with Gain control



NEW

DJ Audio Interfaces

Gemini Slate Quad

DJ USB MIDI Controller

Built with DJ tools such as a pitch fader, key-lock, and advanced effect controls to give you instinctive ease of use.

- 8 multi-colour pads (per deck) control
- 4-channel mixer with 3-band EQ
- Filter control on each channel
- Pre-mapped FX controls for Serato DJ Intro
- High Resolution touch-sensitive jog wheels
- Responsive controls with high-resolution 14-bit MIDI
- Midi mapping functionality over the entire controller
- 1/4" mic input with Gain control



NEW

Description	Code	Price (Ex VAT)
Slate DJ	290-100	£165.00
Slate Quad	290-110	£207.50

Numark DJIIO 2

USB Audio Interface

A simple way to get up and running with any DJ controller that lacked a built-in audio interface.

DJIIO 2 is an updated and enhanced version of DJIIO that features new routing capabilities and the ability to record audio directly to your computer. DJs and other performers can employ DJIIO2 in a wide variety of performance environments, including setups involving music-mixing software and a hardware controller such as TOTAL CONTROL, STEALTH CONTROL, or MixMeister Control. Other performers, including CD DJs and non-musician computer users, can appreciate DJIIO's portability and small footprint. DJIIO2 features high-quality, audio playback with 24-bit / 44.1kHz resolution and an ultra-low-latency signal path designed for real-time, pro-quality mixing.

Description	Code	Price (Ex VAT)
DJIIO 2	277-600	£45.82



NEW

Numark

MORE PRODUCTS
online

Keep up to date with all the latest products and current prices on the new look **Studiospares** website!

Check out www.studiospares.com

DJ Production Tools

Korg Kaoss Pad KP3+

Production Tool

No other interface is as intuitive, immediate or just plain fun to use!

Korg's KAOSS technology allows you to control multiple effects parameters in real time by simply touching, tapping or sliding your finger over the touchpad. This latest KAOSS incarnation features a new pad lighting system that provides visual cues as to the current program, held position, and more - it can even scroll a custom message across the pad! The KP3+ comes equipped with 128 newly developed effect programs designed to appeal to musicians, producers and DJs alike.



KORG

Description	Code	Price (Ex VAT)
KAOSS Pad KP3+	273-670	£249.16

Korg Mini-KP2

Dynamic Effects Processor

Ready for the stage, studio, or dance floor, the self-contained Mini Kaoss Pad 2 offers dazzling real-time performance effects.

- Controls and modulates cutting-edge effects
- MP3 player with microSD card slot for audio
- Add effects to audio without additional gear
- 100 effect programs + MP3/WAV playback
- 3 Program memory locations instant recall
- Powerful Looper, Vinyl Break, and Ducking
- Internal mic and external audio inputs
- 6 preset audio demo loops



Description	Code	Price (Ex VAT)
Mini-KP2	283-220	£108.32

Arturia Spark LE

DJ Controller

Combines the amazing sounds, work flow and creative tools of the Spark Engine software, with the high quality SparkLE controller.

- Backlit velocity/pressure sensitive Pads
- Touch sensitive FX pad
- Mode selector - Bank, Pattern, Seq, Tune Bus powered, class compliant USB input
- User assignable encoders
- Advanced Looper Divide/Move function
- Protective travel sleeve. Small, Portable. Solid construction
- MIDI mode for use as a controller with any software
- See www.studiospares.com for full specs



Description	Code	Price (Ex VAT)
Spark LE	221-010	£165.83

Arturia Beatstep

DJ Production Tool

Offers a new degree of functionality and performance for a portable pad controller.

- 16 backlit pads
- 16 assignable encoders with 2 modes: MIDI CC and NRPN/RPN
- Transport Buttons
- Data Dial
- Kensington Lock
- MIDI CC mode - RED LEDES
- 16 user presets
- Multiple pad modes
- Step Sequencer - BLUE LEDES



Description	Code	Price (Ex VAT)
Beatstep	221-070	£74.17

VISIT
our trade counter

You'll get friendly advice and immediate access to 8000+ product lines!

free parking for 40 cars

PDF catalogue

Want this catalogue on your phone or laptop?

The Studiospares catalogue is now available in PDF format.

visit www.studiospares.com/page/pdfcatalogue/

WANT a job?

Are you looking for a stable and rewarding career?

Studiospares are constantly expanding. We require additional staff for a variety of positions, working in a very congenial atmosphere. Practical experience of recording and/or live sound engineering would be preferable.

send in your CV in the first instance

Akai MPC Fly Controller

Production Tool

Embodies Akai's legendary capabilities that have made the MPC an industry standard.

- Real MPC pads, MPC Note Repeat and MPC Swing
- Fitted compartment for iPad provides fully integrated portable MPC solution
- Works seamlessly with the MPC App: sequence & sample editing, effects, EQ and more
- Mac or PC compatible



NEW LOWER PRICE

Description	Code	Price (Ex VAT)
MPC Fly Controller	265-750	£107.50

Numark IDJ Live 2

DJ Controller

DJ Controller for Mac, PC, iPad, or iPhone. Two large performance turntables and a central mixer section and crossfader.

- Crossfader, EQ controls, and capacitive touch-activated platters
- Algoriddim's djay LE software for Mac included
- Seamless integration with Algoriddim's djay@ and vjay@ apps (sold separately)
- Headphone/speaker splitter cable and stand for iPad included
- USB bus-powered



NEW LOWER PRICE

Description	Code	Price (Ex VAT)
Live 2	277-570	£70.00

Zoom RT-223 Rhythm Track

Drum Machine

Seventy different kits from Rock Drum to Voice Percussion.

- Twelve built-in bass sound sources
- COMP EQ and REVERB effects
- 440 preset patterns
- Touch-sensitive pads
- MIDI IN and external line input



Description	Code	Price (Ex VAT)
RT-223	377-750	£107.50

IK iRing

iOS Motion Controller

Uses patented advanced image-recognition, motion control and precise geometric positioning technology.

- A simple double sided ring that fits comfortably between your fingers
- On one side is a linear pattern of 3 dots, on the other a triangular pattern
- Control your music apps and effects without touching device
- Motion controller for iPhone, iPad and iPod touch



NEW

Description	Code	Price (Ex VAT)
iRing Green	321-740	£14.99
iRing Silver	321-741	£14.99
iRing White	321-742	£14.99

DELIVERY BEFORE NOON
no problem

ALL PRICES EXCLUSIVE OF VAT.

INDEX

Computer Zone	
Audio Interfaces	PCI 64
	USB 64
	Firewire 71
	Hybrid 72
	iPhone/iPod 72
	Thunderbolt 73
	Network 74
Computer Monitoring	75
Digital Converters	76
MIDI Interfaces	76
MIDI Controllers	77
MIDI Keyboards	78
Synthesizers	81
Samplers	82
Sound Modules	82
Audio Converters	82
General Interfaces	82
External Hard Drives	82
Computer Accessories	83
Software	84

COMPUTER

Audio Interfaces/Sound Cards - PCI

ESI MAYA44

PCI Audio Interface 24/192 4In/4Out

The MAYA44 is a high quality audio interface providing a number of powerful features optimized for home recording and for DJ applications.

- Supports up to 24-bit / 192kHz output and 96kHz input
- 4 analogue input and 4 analogue output channels
- Headphone output with gain control



Description	Code	Price (Ex VAT)
MAYA44	224-370	£64.68

COMPUTER

Audio Interfaces/Sound Cards - USB

Behringer Control 1 USB

USB Interface

Puts Master Volume, Talkback, Source selection and Monitor control right at your fingertips.

- Choose from 3 sets of active studio monitors and 4 different stereo ins
- Talkback mic lets you communicate directly with performers
- High-quality, built-in USB audio interface
- Phono preamp for direct turntable connection
- 2 powerful headphone amplifiers with separate volume controls



Description	Code	Price (Ex VAT)
Control 1 USB	383-590	£107.50



MOTU 8Pre

USB 2.0 Audio Interface



NEW

Turn your computer into a powerful digital audio workstation with eight mic inputs, or add eight high-quality mic/instrument inputs to your current system.

The 8pre audio interface delivers everything you need to turn your computer into a powerful 24-bit, 96kHz digital audio workstation. The 8pre provides eight microphone/instrument preamps with pristine 96kHz analog recording and playback, combined with 8 channels of ADAT optical digital I/O. Expand your system by connecting additional 8pres or other MOTU audio interfaces.

Description	Code	Price (Ex VAT)
8Pre	375-600	£362.50



Motu Track16

Desktop Studio Interface

16 x 14 Desktop Studio Interface.

- CueMix FX that includes classic reverb, modeled analogue EQ and modeled vintage compression
- Hybrid technology connects to any computer
- Mixes 16 inputs (8 stereo) to an output pair
- You can adjust input volumes differently for each output pair
- Each output pair can have its own unique mix
- You get a separate mix for main outs, line outs, optical digital outs and phones
- Connect to Mac or PC via FireWire or USB 2.0



Description	Code	Price (Ex VAT)
Track16	375-550	£395.83

Apogee One

iPad/Mac Audio Interface

An affordable portable pocket sized music interface.

- USB 2.0 audio with 24-bit/96kHz A/D
- Built-in omnidirectional condenser microphone (stand adapter included)
- 2 Analogue Inputs (XLR microphone and 1/4" instrument connector on breakout cable)
- 1/8" stereo output for headphones or powered speakers



Description	Code	Price (Ex VAT)
One	321-020	£249.17

Apogee Quartet

iPad/Mac Audio Interface

Delivers professional performance for iPad along with low latency USB 2.0 performance.

- Works with new iPhone 5, iPad (4th generation), iPad mini, iPod touch
- 4 channels of Apogee A/D conversion and microphone preamps
- 8 outputs, Independent speaker and headphone outs
- 2 full colour LED display.; MIDI I/O



Description	Code	Price (Ex VAT)
Quartet	321-070	£915.83

Apogee Duet for iPad and Mac

USB Audio Interface

Makes it easy to create professional recordings anywhere on your iPod touch, iPhone, iPad or Mac

- Duet charges the iPhone, iPod Touch, or iPad when connected
- 2 analogue inputs with world-class mic preamps and selectable 48v phantom power
- Direct connection with Lightning or 30-pin iOS devices and USB connection to Mac
- Works with iOS 7 on iPad, iPhone, iPod touch



NEW

Description	Code	Price (Ex VAT)
Duet for iPad and Mac	321-080	£399.17

Akai EIE I/O

Interface Expander

Connect virtually any musical instrument or piece of production gear to your computer.

- 16-bit recording interface with high-quality components
- 3 convenient USB inputs in addition to its main USB port
- XLR-1/4" combo jack, dedicated gain-pot and Mic/Line/Guitar switch on each channel



Akai EIE I/O Pro

Tabletop USB 2.0 Audio Interface

Perfectly tailored for your project and portable studio setups.

- Four-in, four-out (4x4) device features low latency ASIO drivers
- 24-bit resolution and sample rates of 44.1 kHz/48 kHz/88.2 kHz/96 kHz
- Compatible with Mac and PC-based systems
- XLR-1/4" combo jack, dedicated sturdy, gain-pots and Mic/Line/Guitar switches on each channel
- 48V phantom power available



Description	Code	Price (Ex VAT)
EIE I/O	265-770	£115.83
EIE I/O Pro	265-780	£140.83

DELIVERY BEFORE NOON
no problem

Audient ID22

22-Channel USB2 Audio Interface

Transforms your DAW into a world-class recording system by connecting directly to your mics, computer and monitors.

- 2-in, 6-out high performance 24-bit/96kHz AD/DA converters
- 2 superb class-A mic preamplifiers & 1 discrete JFET instrument input
- High current headphone amplifier fed by an independent DAC
- Main and alternative stereo outputs
- User defined monitoring functionality with hardware control
- USB2 class compliant connectivity



NEW

Audient ID22/Mico Pack

Audio Interface Bundle

Package containing the Audient ID22 High Performance Audio Interface with the MICO Dual Microphone Preamp.

NEW

Audient ID22/ASP880 Pack

Audio Interface Bundle

The Audient ID22/880 Pack consists of an Audient ID22 Audio Interface and an Audient ASP880 8 Channel Microphone Preamplifier and ADC.

NEW

Description	Code	Price (Ex VAT)
Audient ID22	201-000	£374.17
Audient ID22/Mico	201-010	£689.00
Audient ID22/ASP880	201-020	£1082.50

Line 6 Sonic Port

Audio Interface

Allowing you to put your guitar or keyboard sounds into your iDevice and build a mobile studio.

- 24-bit/48kHz audio quality throughout
- Guitar input/output on a standard Jack plug
- 110dB dynamic range on guitar input
- Mini Jack stereo line input
- Stereo headphone output
- Mobile POD app a free download providing 32 amps, 16 FX and 16 speaker cabinets, over 10,000 presets designed by artists. Line 6 and other players
- Built-in chromatic tuner



Description	Code	Price (Ex VAT)
Sonic Port	301-620	£57.50

Mackie Onyx Blackjack

2x2 USB Audio Interface

Featuring 2 boutique-quality Onyx preamps in an ultracompact, ergonomic desktop design, the Blackjack is perfect for your home studio

- High-end AD/DA converters
- Built-in DIs and phantom power
- Hassle-free zero-latency tracking
- Ultra-low noise and distortion
- Professional 24-bit recording/playback via 2x2 USB
- Includes Traktion 3™ software



Description	Code	Price (Ex VAT)
Onyx Blackjack	262-400	£115.00

Tascam US-1800

USB Audio Interface



A Rackmountable Audio and MIDI Interface which is ideal for the project studio.

The US-1800 has eight studio-quality microphone inputs with phantom power, two line/instrument switchable inputs on the front, four additional balanced line inputs on the rear, overload indicators for each input, four line-level outputs, digital SPDIF I/O (output switchable to AES/EBU), independent monitor and headphone outputs with separate level controls and 16 channels of MIDI I/O. It offers zero-latency hardware monitoring and sampling rates up to 96kHz at 24-bit resolution. Cubase LE 5 is supplied as standard.

Description	Code	Price (Ex VAT)
US-1800	238-040	£232.50

TASCAM

Tascam US-1200

USB Audio Interface



6-In / 2-Out Rack-Mount Audio Interface with DSP Mixer.

- Equipped with High-Quality HDDA (High Definition Discrete Architecture) Microphone Preamplifiers
- 6 Analogue inputs for Multi-Channel Recording
- Low-Latency Monitoring for Stress-Free Recording
- Supports Hi-Res Recording Up To 24 bit/96 kHz
- On-board DSP mixer with 2 operational modes
- On-board digital effects(DSP effects)(DSP effects can use on 44.1/48kHz operating)

NEW

Description	Code	Price (Ex VAT)
US-1200	238-430	£140.83

Tascam UH-7000

Audio Interface/Mic Preamp

Designed with a strong focus on low noise and high audio quality.

- HDIA mic preamps capture detailed nuances
- Excellent input audio circuit specifications
- Audio quality has been fine-tuned through listening evaluations and recording tests
- Large aluminum input level knobs and 20-segment LED level meters
- Switch operation modes between standalone mic pre and audio interface mode



NEW

Description	Code	Price (Ex VAT)
UH-7000	238-440	£374.17

Behringer U-Phono UFO202

USB Audio Interface

High-quality USB audio interface for digitalising your tapes and vinyl records.

- Massive software bundle included
- Phono input switchable to line input source
- Stereo output
- High-resolution 48kHz converters



Description	Code	Price (Ex VAT)
UFO202	382-390	£27.50

Behringer UCA222

U-Control - USB Audio Interface



NEW LOWER PRICE

An ultra flexible audio interface that connects your instruments, mixer, etc. with your computer for recording and playback.

The revolutionary energyXT2 Compact music production software is included with a rich audio/MIDI sequencer that loads almost instantaneously on all computer platforms. Its massive software bundle includes Audacity audio editor, comprehensive podcasting software and over 150 virtual instruments and effect plug-ins. The UCA222 works with your PC or Mac computer and no setup or drivers are required. Its high quality components and exceptionally rugged construction ensure long life.

Description	Code	Price (Ex VAT)
UCA222	382-380	£18.75

PRICE changes

This catalogue was priced on 1st December 2014.

Current prices may be higher...

see our website for up to date prices.

SATURDAY DELIVERY no problem

DELIVERY BEFORE 10AM no problem

ALL PRICES EXCLUSIVE OF VAT.

COMPUTER

Audio Interfaces/Sound Cards - USB

CONTINUED

ESI MAYA44 USB

4 in/4 out Audio Interface

Provides a number of powerful and amazing features optimized for home recording and for DJ applications...

MAYA44 is a high quality 24-bit 96/192kHz 4-in / 4-out Audio Interface. The card can easily be used by home users making their first steps in computer audio as well as by professionals producing music on a budget. MAYA44 provides 2 stereo analogue line inputs, 2 stereo line outputs, a microphone input with +48V phantom power as well as an optical and coaxial SPDIF output that can be used to pass through AC3/DTS signals. There is also a headphone output, perfect for monitoring.

Description	Code	Price (Ex VAT)
MAYA44	224-240	£61.50

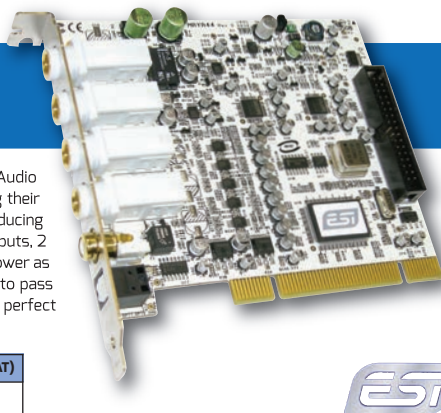

ESI U24 XL

USB Audio Interface

Continues ESI's tradition of offering extremely small and portable audio devices of excellent quality.

- 2 x 1/4" analogue I/O channels
- 1 x output connector usable as headphone output
- SPDIF digital I/O available via Toslink and RCA connectors



Description	Code	Price (Ex VAT)
U24 XL	224-270	£65.83

Alesis Core 1

1 Channel Inline USB Audio Interface

Ideal for on-the-go recording or the budget-conscious producer.

- 2-channel mini USB, 24-bit/48 kHz output
- 1 XLR+1/4" TRS combo input with gain knob
- Mic/Line or Guitar level switch
- Stereo headphone out with level control
- Modern sand-blasted aluminum housing



Description	Code	Price (Ex VAT)
Core 1	395-090	£33.32

Alesis IO4

4-Channel 24-Bit Interface

Four channels of premium-quality audio into your computer.

- 48kHz 24-Bit USB audio interface
- 4 channels with inputs for microphones, line-level sources, and instruments
- High-quality converters, preamps and 48V phantom power
- MIDI input and output and dedicated headphone output



Alesis IO Hub

Studio Hub

Two channel USB Audio interface for a Mac or PC, no frills and simple to use.

- iBus powered—no power supply required
- Both inputs come with XLR+1/4" Jacks
- Phantom power for condenser mics
- Channel 2 provides an additional switch that allows the Hi-Z signal from a guitar or bass to be connected to the IO Hub
- Direct switch allows zero-latency monitoring of the input signal
- Headphone output with volume control



Description	Code	Price (Ex VAT)
iO4	385-610	£83.32
iO Hub	395-010	£54.16



Alesis IO2 Express

USB Audio Interface

Compact, audio-recording interface for home studios and portable recording setups.

- 2-channel USB device with up to 24-bit resolution for input into virtually all DAW, recording, and performance software
- High quality A/D and D/A converters
- I/O includes USB, MIDI, XLR, TRS
- Comes with Cubase LE software



Description	Code	Price (Ex VAT)
IO2 Express	385-480	£66.66

Alesis Guitarlink I/O

Guitar Interface

1/4" to USB cable directly links guitar to computer.

- Contains an internal analogue-to-digital conversion system
- CD Quality 16-bit, 44.1kHz audio
- No drivers to be installed and works with both Mac and PC



Description	Code	Price (Ex VAT)
Guitarlink I/O	395-000	£54.16

WANT a job?

Are you looking for a stable and rewarding career?

Studiospares are constantly expanding. We require additional staff for a variety of positions, working in a very congenial atmosphere. Practical experience of recording and/or live sound engineering would be preferable.

send in your CV in the first instance

MORE PRODUCTS online

ESI Gigaport HD

8-OUT USB Audio Interface



Perfect for the digital DJ on the road working with a laptop.

The ESI Gigaport HD is not like any other USB Audio Interface, offering great value for money due to its unique set of features providing 8 independent outputs (and full 7.1 surround sound support), 2 independent stereo headphone outputs and excellent audio quality supporting up to 24-bit and 96kHz. With ASIO 2.0 and GSIF drivers for professional audio mixing and playback under XP and Vista, the hardware is also CoreAudio compatible and natively works under Mac OS X. Simply use your favourite DJ software and the eight outputs as up to 4 different stereo channels, enabling you to mix, cue and add effects. Monitor and pre-listen to your signals via the two built-in headphone outputs.

Description	Code	Price (Ex VAT)
Gigaport HD	224-230	£94.00

USB Guitar Link

Cable Interface

Turn a PC or Mac Computer in to a guitar amp and recording system without the need for any specialist hardware.

- Works directly with PC or Mac computer
- Ultra-Low latency driver for PC included
- Variable-speed file playback function for MP3, WAV, AIFF files
- Can be used for monitoring with active monitor speakers
- USB bus powered, requires no external power



Description	Code	Price (Ex VAT)
Guitar Link	602-980	£12.49

VISIT our trade counter

You'll get friendly advice and immediate access to 8000+ product lines!

Focusrite Scarlett Series

USB Audio Interfaces

High quality audio interfaces featuring professional grade preamps to cater for any scenario.

2i2

The Scarlett 2i2 is a 2 in / 2 out USB recording interface featuring two Focusrite mic preamps housed in an attractive anodized aluminium unibody chassis. Excellent 24-bit digital performance and sample rates of up to 96kHz. Rugged metal unibody case.

2i4

Similar to the 2i2, but with a 2 in / 4 out USB audio interface.

Studio

The complete professional recording package for musicians. Based on the popular Scarlett 2i2 USB interface from Focusrite. Includes Focusrite's studio condenser microphone, the CM25, plus HP60 studio monitoring headphones. Comes with powerful music production software Cubase LE6.

18i20

Multi-channel USB-based audio interface. 18 inputs and 20 outputs with 24-bit/96kHz A-D/D-A conversion. Microphone preamplifiers with up to 60dB of gain and phantom powering. Includes Ableton Live Lite, Scarlett mix Control, Scarlett Plug in Suite, Novation Bass Station VST Synth and a 1Gb Sample pack from Loopmasters royalty free samples.

6i6

6 inputs and 6 outputs that connects to your PC, Mac or iPad via USB 2.0. It has two award winning Focusrite microphone preamplifiers, which deliver superb quality. 2x Mic/line/instrument inputs with rear panel. Line inputs (3-4). 4x Line outputs via Jacks. 2x Headphone outputs. MIDI in and MIDI out plus USB2.0. SPDIF ins and outs on rear panel. Supplied with Ableton Live Lite, Scarlett Mix. Control, Scarlett Plug-in Suite, Novation Bass Station and a 1Gb Sample pack from Loopmasters royalty free samples.

18i8

18-in/8-out interface which offers a series of high-quality inputs and outputs for different recording requirements. With four Focusrite mic pres, the 18i8 can record a significant number of sources at the same time. Works on Mac, PC and iPad (Apple Camera Connection Kit required for iPad). Supplied with Ableton Live Lite, Scarlett Mix Control, Scarlett Plug-in Suite, Novation Bass Station and a 1Gb Sample pack from Loop masters royalty free samples.

Solo

Sleek, light and tough enough to take whenever you go, Scarlett Solo turns your Mac or PC into a portable recording studio. Precision convertors will transform your live performance into studio-quality 24-bit resolution digital audio, with sample rates of up to 96kHz and an exceptional dynamic range of over 105dB.



2i2



Studio



18i20



6i6



18i8



Solo

Description	Code	Price (Ex VAT)
Scarlett 2i2	389-820	£90.83
Scarlett 2i4	389-860	£124.17
Scarlett Studio	389-870	£165.83
Scarlett 18i20	389-880	£332.50
Scarlett 6i6	389-890	£165.83
Scarlett 18i8	389-900	£232.50
Scarlett Solo	392-060	£66.66



For more information and accessories on these products, please see our website.

COMPUTER

Audio Interfaces/Sound Cards - USB

CONTINUED

M Audio M-Track Series

Audio MIDI Interfaces

Transforms your computer into a digital recording studio with plug-and-play simplicity.

M-Track

With 24-Bit 48kHz processors it transforms your computer into a digital recording studio with plug-and-play simplicity. USB cable provides both power and a data. 2x XLR/ Mic inputs with phantom power. 2x Line level Jacks with guitar level switching. 2x Jack Insert points, MIDI Ins and Outs plus SPDIF digital I/Os. Outputs on Jacks with a level control and insert point on each channel.

Includes both Ignite by AIR and Ableton™ Live Lite music software programs.



M-Track Plus

Same specification as M-Track Audio and MIDI interface but includes two complementary software selections: Avid® Pro Tools® Express and Ignite by AIR music creation software.



M-Track Quad

Essentially the same facilities as the M-Track and M-Track Plus. Differences are 4x Mic/Line inputs, 4x Insert points, Outputs 1 and 2 have variable outputs whilst 3 and 4 have fixed level outputs, Stereo/Mono switch, USB connection with 3x ports. Power supply included.



M-Track Eight

This eight-input USB audio interface enables you to track large music ensembles, record the band, or mic an entire drum set with pro-grade audio components and a myriad of connections. Eight combo XLR+1/4" inputs accommodate nearly any source, from phantom-powered microphones to your favorite guitar, and eight dedicated outputs offer versatile playback options. The XLR inputs are designed to work with microphones and other Lo-Z sources, and the phantom power switch enables you to use condenser microphones by delivering 48v phantom power to the XLR inputs (Channels 1-4; 5-8). M-Track Eight also has two conveniently located inputs on the front panel that can be switched to allow instrument-level signals, so you can plug your electric guitar or bass directly into M-Track Eight and start recording.



Description	Code	Price (Ex VAT)
M-Track	374-110	£66.66
M-Track Plus	374-120	£107.50
M-Track Quad	374-130	£165.83
M-Track Eight	374-210	£240.83

M-AUDIO

Roland UA-1610

Studio Capture

Durable and capable of handling large-scale recording projects in the studio and on the road.

- 24-bit/192 kHz audio quality
- 16 audio inputs (12 premium mic preamps with XLRs and phantom powering)
- 10 Audio outputs
- AUTO-SENS intelligently sets optimal input levels for all preamps
- Coaxial digital I/O; MIDI I/O
- Easily linked to another CAPTURE with a single driver
- 2U rackmount ears included



Description	Code	Price (Ex VAT)
UA-1610	309-990	£665.83

PreSonus Audiobox iOne

Audio Interface

Ideal for vocalists and electric guitarists that are on-the-go.

- High-performance Class A preamplifier with phantom power
- Records audio at up to 24-bit, 96 kHz sampling resolution
- Stereo headphone output with dedicated level control
- Includes Studio One Artist DAW software
- Balanced main outputs for connecting studio monitors



NEW

PreSonus Audiobox iTwo

Audio Interface

Ideal for recording band rehearsals, demos, keyboard workstations and more.

- High-performance Class A preamplifier with phantom power
- Records audio at up to 24-bit, 96 kHz sampling resolution
- Doubles as a full-functioned MIDI interface, including standard MIDI in and MIDI out ports
- Stereo headphone output with dedicated level control



NEW

PreSonus Audiobox iTwo Studio

Audio Interface Package

The PreSonus Audiobox iTwo Studio gives you everything you need to start recording anywhere you want. The Package includes PreSonus AudioBox iTwo USB/iPad audio/MIDI interface, a Studio One Artist DAW software (Mac/Windows), a Capture Duo recording software (iPad), an M7 large-diaphragm condenser mic and High-definition HD7 headphones.

PreSonus Audiobox Stereo

USB Stereo Hardware/Software Recording Kit

Recording rehearsals and performances in schools, churches, and studios is easy with the PreSonus® AudioBox™ Stereo recording kit! This special all-PreSonus system combines an AudioBox USB interface with Studio One® Artist music-production software, HD7 monitoring headphones, a pair of P5625 small-diaphragm condenser microphones, and all necessary cables and mounts.

Description	Code	Price (Ex VAT)
iOne	338-000	£82.50
iTwo	338-010	£107.50
iTwo Studio	338-020	£165.83
Stereo	338-030	£182.50

NEW

Roland Duo Capture

USB Interface

Perfect for both home recording and mobile production.

- Contains 2 V5 Preamps as used in Roland's high-end digital mixers
- Hi-Z input for connecting a guitar or bass directly
- 3 power options: USB, batteries, or an optional AC adapter
- Phantom-power support
- Housed in a road-tough metal case



Description	Code	Price (Ex VAT)
Duo Capture	309-920	£99.17

Roland UM-ONE MKII

USB Interface

Boasts high-performance FPT processing for low latency and tight timing.

- MIDI interface compatible with Macs and PCs, and the iPad
- Data indicators for both MIDI input and output
- Super-compact, affordable, and easy to use
- USB bus-powered operation



Description	Code	Price (Ex VAT)
UM-ONE MKII	309-930	£24.17

SATURDAY DELIVERY
no problem

Focusrite iTrack Solo

USB Interface

Provides the best solution for recording your instruments and vocals using an iPad.

- Featuring a renowned Focusrite microphone input
- Record both vocals and your instrument simultaneously to separate tracks
- Encased in a rugged aluminium unibody chassis
- Phono outputs for connecting to iTrack Solo or powered speakers
- Also works with Mac and PC



Focusrite iTrack Studio

USB Interface

Everything you need to start making music on the iPad, Mac and PC.

- Includes Focusrite iTrack Solo audio interface, studio-quality microphone, headphones and cables
- Free recording App for iPad. Ableton Live Lite, Scarlett Plug-in Suite (compressor, reverb, gate and EQ), Loopmasters sample content and Novation Bass Station soft-synth are included for Mac and PC users.



Focusrite iTrack Dock

Cable Interface

Comprehensive yet easy-to-use, studio-quality iPad recording interface.

- Two legendary Focusrite microphone preamps
- Two line inputs and an instrument DI with plenty of extra headroom
- Stereo monitor outputs with 105dB dynamic range
- Headphone outputs
- USB port for class compliant MIDI instruments and controllers



Focusrite iTrack Dock Studio Pack

Cable Interface Bundle

The iTrack Dock Studio Pack contains everything you need to plug your instruments straight in and easily record. It includes a Sleek iPad audio interface with two award-winning microphone preamps, a large diaphragm CM25 condenser microphone, professional closed-back HP60 headphones, a high quality 3m XLR cable and a class compliant USB cable.

Focusrite iTrack Pocket

Stereo Microphone and Guitar Input

A portable, high quality stereo mic and guitar input that lets you create and share exceptional videos using your iPhone.

- Instant HD Recording
- Stereo microphone captures clear, detailed recordings of your performance
- Dedicated guitar input with built-in amp simulation
- Connect to any lightning compatible iPhone with the Lightning cable included
- Frequency Response 20Hz - 20kHz



Behringer FCA1616
Audio Interface

Instantly turns your computer into a powerful recording and editing workstation



With its expanded 16 channel I/O, 4 MIDAS designed mic preamps and ADA8000 ADAT connectivity, the FCA1616 stands out among the FCA series as ideal for more permanent applications, such as home and professional recording studios, as well as live performance multi-track recording rigs. With its small size and low-latency operation, it ranks among the best devices for travelling musicians who record and edit on their laptops. All standard I/O formats are supported including analogue, S/PDIF (coaxial and optical), ADAT and S/MUX, while built-in MIDI I/O allows you to connect keyboards and other outboard MIDI hardware. The single rack-space FCA1616 also features 8 analogue Inserts for use of external effects such as compressors, gates and EQs, etc. A dedicated power supply is included.

Behringer FCA610

With 10 input channels and 6 outputs, as well as 2 MIDAS designed mic preamps with phantom power, individual Pad, Low Cut and Hi-Z and ADA8000 ADAT connectivity, the FCA610 is ideal for more permanent applications, such as home and professional recording studios, as well as live performance multi-track recording rigs. With its small size and low-latency operation, it also ranks among the best devices for travelling musicians who record and edit on their laptops. All standard I/O formats are supported including analogue, S/PDIF (coaxial and optical), ADAT and S/MUX, while built-in MIDI I/O allows you to connect keyboards and other outboard MIDI hardware. A dedicated power supply is included. FireWire and USB 2.0 ports are situated on the rear panels of the FCA610. Inputs are balanced 1/4" jacks that accept a wide range of line-level devices. Outputs accept both balanced and unbalanced 1/4" connections. The two headphones jacks are conveniently located on the front panel, with a dedicated volume control.



Description	Code	Price (Ex VAT)
FCA1616	384-010	£165.83
FCA610	384-020	£120.83



Focusrite Forte

USB Interface

Designed to deliver analogue sources to your DAW at the highest possible quality.

- Professional 2 in, 4 out portable USB audio interface for Mac and Windows
- Two remote-controlled Focusrite mic preamps
- Superb digital conversion at up to 24-bit/192kHz resolution
- Connects to both Mac and Windows computers via USB 2.0
- Elegant aluminium case includes non-slip strips on the base



Description	Code	Price (Ex VAT)
Forte	389-850	£207.50

Behringer IS202

iStudio Docking Station

Simply connect the mixer's outputs to iSTUDIO, open the recording app and go.

- Craft and create music in any situation
- 2x XLR/Jack inputs each with gain control
- Switchable phantom power
- Onboard MIDI USB interface
- Direct guitar high impedance input
- Stereo Aux Input, for line-level sources
- Slide-in access for mating with iPad dock



Description	Code	Price (Ex VAT)
IS202	384-030	£99.99

PDF catalogue

Want this catalogue on your phone or laptop?
The Studiospares catalogue is now available in PDF format.
visit www.studiospares.com/page/pdfcatalogue!

Behringer Guitar Link UCG102

USB Audio Interface

Lets you jam and record using modelling amps and effects without the need for any other gear but your guitar.

- Includes Guitar Combos Behringer Edition from Native Instruments
- Kristal Audio Engine multi-track sequencer
- Headphone output for silent practicing
- Ultra-low latency ASIO driver for PC included
- Variable-speed file playback function for MP3, WAV, AIFF
- Mac & PC Compatible



Description	Code	Price (Ex VAT)
UCG102	381-630	£27.50

DELIVERY BEFORE 10AM
no problem

MORE PRODUCTS online

COMPUTER
Audio Interfaces/Sound Cards - USB

CONTINUED

Roland UA-55 Quad Capture

4 in/4 out Audio Interface

Sets a new standard for portable USB 2.0 audio interfaces...



This update to the highly popular UA-5 brings better connectivity and enhanced performance. With a pair of premium VS Preamps onboard, plus superb 24-bit/192 kHz audio quality, ultra-low latency performance, and convenient USB bus power, the UA-55 QUAD-CAPTURE sets a new standard for portable USB 2.0 audio interfaces. Its compact, durable design and pristine sound makes it the perfect foundation for portable, multichannel computer-based productions on the go. Two combo XLR/TRS inputs with premium VS Preamps for mics. Two TRS outputs, coaxial I/O, headphone out, and MIDI I/O. Graphical Control Panel software provides fast, intuitive control of the VS Preamps. One-click AUTO-SENS function intelligently sets optimal input levels for the preamps. Extreme low-latency VS Streaming driver with Low-noise, wide-range power supply. Impact with durable aluminium body and Direct Box functionality. Supplied with Cakewalk SONAR X1 LE.

Description	Code	Price (Ex VAT)
UA-55	309-590	£157.50

IK iRig Pre

Mic Interface

The first studio-quality mic-preamp for the iOS platform.

- Create music any time, anywhere
- Simple, intuitive use
- Plug microphone into your iOS device
- Phantom power available



Description	Code	Price (Ex VAT)
iRig Pre	321-530	£20.82

IK iRig Guitar/Bass

Guitar/Bass Interface

The iRig is a revolutionary product that allows you to connect your guitar/bass to your iOS device.

- Instrument interface adaptor + guitar and bass tone mobile software
- Works with iPhone/iPod touch/iPad
- Compact 1/4" female input jack to 1/8" female output
- Real time guitar and bass multiFX, recording, practicing app



Description	Code	Price (Ex VAT)
iRig Guitar/Bass	321-560	£20.82

Studiospares USB A/D Interface Leads



XLR

JACK

PHONO

16bit/48kHz Cable Type USB A analogue audio interface simple and small. Converts analogue signals to digital data and sends it to your computer to be recorded. USB powered WIN98 SE, WIN2000, WIN, ME, WIN XP that is widely used in PC and some audio equipment. Impedance: 90±13% Ohms Transmission speed: 24Mbps and above.

Leads	Description	Code
XLR	USB2.0 A Male to 2XLR male + 2XLR female 2m long.	589-960
Jack	USB2.0 A Male to 4x Quarter inch Jack plugs 2m long.	589-970
Phono	USB2.0 A Male to 4 Phono plugs 2m long.	589-980

Description	Code	Price (Ex VAT)
USB 2.0 - 4x XLR	589-960	£16.90
USB 2.0 - 4x Jack	589-970	£16.90
USB 2.0 - 4x Phono	589-980	£16.90

M-Audio Vocal Studio Pro

Complete Vocal Studio Package

The all-in-one solution for your computer-recording projects.

Package Contents:

- M-Audio M-Track Interface
- M-Audio large diaphragm vocal microphone
- M-Audio studio headphones
- Avid Pro Tools Express with iLok USB key
- Ignite by Air (Download)
- Mic clip
- XLR microphone cable
- USB cable
- User Guides
- Safety & Warranty Manual



Description	Code	Price (Ex VAT)
Vocal Studio Pro	374-190	£149.17

MORE PRODUCTS online

Prism Sound Lyra 1/2

Audio Interface

Based on the new ARM Cortex-based processor design which offers class-compliant USB and Ethernet AVB interfacing.

- Class compliant (UAC2) USB interface
- ASIO drivers for Windows (32 and 64bit)
- Native CORE AUDIO on Mac OS X
- UAC2 operation on Linux (no control panel support)
- Two Prism Sound premium-quality AD channels
- One/two high-end integrated microphone preamps
- One/two Microphone inputs have switchable phantom power and 20dB pads
- M5 matrix on microphone inputs
- One/two high-impedance front panel instrument inputs
- Two/four Prism Sound premium-quality DA channels
- Independent stereo headphone DA
- Outputs selectable between workstation bus or Lyra mixer

Description	Code	Price (Ex VAT)
Lyra 1 1 Channel	224-800	£1332.50
Lyra 2 2 Channel	224-810	£1830.00

Numark DJiO 2

USB Audio Interface

A simple way to get up and running with any DJ controller that lacked a built-in audio interface.



DJiO 2 is an updated and enhanced version of DJiO that features new routing capabilities and the ability to record audio directly to your computer. DJs and other performers can employ DJiO2 in a wide variety of performance environments, including setups involving music-mixing software and a hardware controller such as TOTAL CONTROL, STEALTH CONTROL, or MixMeister Control. Other performers, including CD DJs and non-musician computer users, can appreciate DJiO's portability and small footprint. DJiO2 features high-quality, audio playback with 24-bit / 44.1 kHz resolution and an ultra-low-latency signal path designed for real-time, pro-quality mixing.

Description	Code	Price (Ex VAT)
DJiO 2	277-600	£45.82

Behringer Podcaststudio USB

Podcast Package

Go on air straight out of the box with this fantastic PODCASTUDIO recording package.

- USB-Control USB audio interface
- Xenyx 502.5 input mixer
- Dynamic microphone
- HPM 1000 headphones
- Behringer edition of Ableton Live Lite 4 for PC and Mac



Description	Code	Price (Ex VAT)
Podcaststudio USB	381-240	£87.50

DELIVERY BEFORE NOON no problem

COMPUTER

Audio Interfaces/Sound Cards - Firewire

Focusrite Saffire Pro 40

Firewire Interface



Focusrite's unparalleled preamp legacy forms the foundation of this new interface. This combined with the very latest in firewire interfacing technology delivers seamless integration, excellent routing flexibility and future-proof, rock-solid driver stability. The eight preamps ensure low noise and distortion, whilst quality digital conversion and JetPLL jitter elimination technology ensure pristine audio quality as your audio flows between the analogue and digital domains. The Pro40 offers a host of I/O options: 10 analogue outputs, ADAT I/O, stereo SPDIF I/O and 2 virtual 'loopback' inputs for routing digital audio between software applications. Every channel features phantom power, with the first two channels also featuring -9dB pads for additional headroom. Front panel 5-LED metering for each analogue input offers accurate viewing of levels. 2 independent headphone outputs each have front-panel controls.

Features eight award-winning Focusrite preamps!

Description	Code	Price (Ex VAT)
Saffire Pro 40	389-640	£332.50
Saffire Pro 40 + Rode NT1A	389-641	£415.83



Focusrite Saffire Pro 14

Firewire Interface



The Saffire PRO 14 is an 8 in / 6 out audio interface with legendary sonic performance and unmatched flexibility at a truly affordable price.

- 2 award-winning Focusrite preamps
- Host of analogue and digital I/O options
- SPDIF and MIDI, plus 2 Hi-Z instrument inputs
- Create 6 separate mixes without latency

Description	Code	Price (Ex VAT)
Saffire Pro 14	389-740	£132.50

RME Fireface 802

Firewire Interface



60-Channel High-end 192 kHz USB/FireWire audio interface.

- 30 Input / 30 Output channels
- High-end microphone preamps and reference class converters
- Ultra-low latency operation with USB or FireWire
- 12 x Analogue I/O and 1 x AES/EBU I/O
- 2 x ADAT I/O (or 1 x ADAT I/O plus 1 x SPDIF I/O optical)
- 1 x Word Clock I/O and 1 x MIDI I/O
- Includes TotalMix FX, RME's digital high-end mixer and signal router, driven by two powerful DSPs, with integrated EQ, Dynamics and Reverb/Echo effects at up to 192 kHz

Description	Code	Price (Ex VAT)
Fireface 802	377-650	£965.83

Focusrite Saffire Pro 24

Audio MIDI Interfaces

Delivers seamless integration, excellent routing flexibility and driver stability.



The Focusrite Saffire PRO 24 features 2 Focusrite pre-amps, mix control software and FireWire interfacing technology. It also has 2 additional analogue inputs, 6 analogue outputs, ADAT inputs, stereo SPDIF I/O and 2 virtual 'loopback' inputs for routing digital audio between software applications - ideal for capturing online audio. The front panel features 5-LED metering for each analogue input offers detailed viewing of levels. The zero latency 18 x 8 DSP Mixer/Router software provided with Saffire PRO 24 features flexible output routing and monitoring, as well as one click set up solutions designed to help you track, monitor and mix as quickly as possible. Focusrite Plug-in Suite included and Focusrite's established Xcite+ bundle is also included. The bundle features Ableton Live Lite, Novation's Bass Station soft synth and over 1 gig of royalty free samples. Total inputs: 16 Total outputs: 8

Focusrite Saffire Pro 24 DSP

As above but with an onboard DSP chip which powers the Virtual Reference Monitoring feature, and tracking tools such as compression, limiting and comfort reverb without any strain on your computer's CPU. also comes with an extra headphone output on the front of the unit so two people can reference the mix using VRM. The Saffire Pro 24 DSP is now available in three different bundle options with the Rode NT1A Pack, 2x XLR Leads or HD280 Headphones. All you need to make high-quality podcasts and home recordings.

Description	Code	Price (Ex VAT)
Saffire Pro 24	389-690	£165.83
Saffire Pro 24 DSP	389-700	£166.66
Pro 24 DSP + Rode NT1A Pack	389-701	£274.16
Pro 24 DSP + 2x XLR Leads	389-702	£199.17
Pro 24 DSP + HD280 Headphones	389-703	£249.17



ALL PRICES EXCLUSIVE OF VAT.

COMPUTER

Audio Interfaces/Sound Cards - Firewire

CONTINUED

Echo Audiofire 12

Firewire Interface

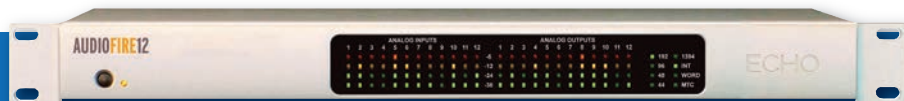

The only FireWire digital audio recording interface of its kind on the market!

Offers 12 balanced analogue inputs and outputs for 24-bit 192 kHz recording and playback. AudioFire 12 also has two FireWire ports so you can daisy-chain two AudioFire 12s for 24 tracks. It also includes MIDI I/O and Word Clock for synchronization. If you already have an audio mixer, tons of microphones, instruments, mic preamps then look no further! 12 balanced 1/4" analogue inputs and outputs.

Description	Code	Price (Ex VAT)
Audiofire 12	379-590	£390.83

ECHO

COMPUTER

Audio Interfaces/Sound Cards - Hybrid

MOTU 828 Mk3 Hybrid

Hybrid Firewire/USB2 Interfaces



Equally well-suited for studio and stage, with or without a computer...

As a hybrid audio interface, the 828mk3 provides flexible connectivity to any Mac or PC via FireWire or high-speed USB 2.0, with ten channels of pristine 192 kHz analog recording and playback, combined with sixteen channels of ADAT digital I/O and stereo S/PDIF. Connect all of your studio gear, including microphones, guitars, synths, keyboards, drum machines and even effects processors. Record, monitor, route and process all of these live inputs using the professional on-board CueMix FX digital mixer - with no latency and no processor strain on your computer. Apply hardware DSP-driven compression, EQ and reverb to every input and output, independent of your host computer. When recording from the mic/guitar inputs, the 828mk3's signal overload protection gives you an extra 12 dB of headroom above zero with no digital clipping or harsh artefacts. Analyse and scope your audio with advanced diagnostic tools, including a full-screen real-time FFT display and spectrogram "waterfall" display.

Description	Code	Price (Ex VAT)
828 MK3	375-440	£524.17

MOTU

COMPUTER

Audio Interfaces/Sound Cards - iPhone/iPad

Tascam iXZ

iPod Interface



The pocket-sized iXZ turns your iPhone, iPad or iPod Touch into a mobile recording studio.

- Switchable mic/line XLR or 1/4" guitar input
- Phantom power for condenser mics
- Gain control
- 1/8" headphone output
- Mic input powered by 2 AA batteries

Description	Code	Price (Ex VAT)
iXZ	238-150	£40.83

IK iRig Keys

iPad/iPhone Controller



The first ultra-slim and highly portable universal MIDI controller keyboard for iPhone, iPod touch, iPad and Mac/PC.

- Features 37 velocity-sensitive mini-keys
- Modulation and pitch bend wheels
- Octave/Program Up/Down back-lit, soft-touch buttons
- Input for an optional sustain or expression pedal
- Incredibly portable

Description	Code	Price (Ex VAT)
iRig Keys	321-600	£49.99

Alesis IO Mix

4-Channel iPad Recorder

The first device that turns your iPad into a powerful portable studio, allowing you to record multiple mics or instruments directly into GarageBand or other Core Audio app.

- Four combo XLR-1/4" input channels and balanced, stereo 1/4" outputs
- Each channel has trim, channel gain, pan, and low & high EQ controls
- High Pass Filters are also available to eliminate low-frequency interference



Description	Code	Price (Ex VAT)
iO Mix	385-920	£165.83

PRICE match

Studiospares will BEAT any genuine price from any UK competitor on any item or order.

details on page 318

Motu Ultralite MKIII Hybrid

Hybrid Audio Interface



Updated to include both USB and Firewire connection options to expand the compatibility of the interface.

- Connect all of your studio gear, including microphones, guitars, synths, keyboards, drum machines, effects processors and even MIDI devices.
- Record, monitor, route and process all of these live inputs using the on-board CueMix FX digital mixer.

Description	Code	Price (Ex VAT)
UltraLite MKIII Hybrid	375-470	£354.17
15V PSU	375-630	£19.00

MOTU Audio Express

Hybrid Firewire/USB 2.0 Interface

The Audio Express is a compact yet powerful and feature packed audio interface.

- 96kHz 24-Bit Firewire/USB2.0 audio interface for Mac and Windows
- 6 In/6 Out with 8 digital busses and a front panel headphone output
- 2 mic/instrument combo XLR/Jack inputs
- S/PDIF Digital I/O and footswitch input



Description	Code	Price (Ex VAT)
Audio Express	375-500	£262.50
15V PSU	375-630	£19.00

SATURDAY DELIVERY no problem

DELIVERY BEFORE NOON no problem

Alesis iO Dock II Pro

Universal Pro Audio Dock for iPad

Connect all your audio gear to the world of iPad music apps.

- Equips your iPad with pro audio connections for recording and live performance
- Interchangeable 30-pin and Lightning connectors included
- Works with virtually any Core Audio or Core MIDI app
- (2) combo XLR-1/4-inch inputs
- (2) 1/4-inch main outputs and 1/4-inch headphone output
- 5-pin MIDI and USB MIDI input and output



MOTU 828x

Thunderbolt/USB2 Interface



MOTU's all-time best selling audio interface, now with Thunderbolt technology and USB 2.0.

Connect up to six devices total (with the 828x at the end of the chain), and the Thunderbolt bus won't even break a sweat. Thunderbolt combines plug-and-play convenience with massive bandwidth and low latency for truly professional audio interface performance. Two combo-style mic/guitar inputs with preamps, 8 balanced analogue in/out, XLR main outs, 16 channels of ADAT optical (8 channels at 96 kHz), plus S/PDIF, word clock and MID. With recording up to 192 kHz the Bunique V-Limit™ hardware limiter offers an additional 12 dB of headroom over digital zero with no digital clipping or harsh artifact. After programming the on-board mixing in the studio, unplug the 828x from the computer and take it on the road for operation as a stand-alone mixer with effects. All mixing and effects parameters are adjustable using the front panel backlit LCD.

Description	Code	Price (Ex VAT)
828x	375-610	£524.17



COMPUTER
Audio Interfaces/Sound Cards - Thunderbolt

UA Apollo 16

Firewire/Thunderbolt Interface



Combines superior sound with powerful onboard UAD-2 QUAD processing.

- 16 x 16 analogue I/O via DB-25 connectors
- Includes dedicated XLR monitor outs and stereo AES-EBU digital I/O
- Realtime UAD-2 QUAD processing for sub-2ms low-latency
- 4x stereo Cue mixes with assignable outputs
- Full recall of interface settings in DAW sessions via Console Recall plug-in (VST/RTAS/AU)
- Flex Routing offers assignable headphone outputs, selectable pre/post Aux sends, headphone bus routing, and vertical resizing of the Console application window

Description	Code	Price (Ex VAT)
Apollo 16	328-900	£2207.50

UA Apollo Twin

Mac/Thunderbolt Interface

Sets a new standard for desktop music production.

- Built in SHARC processors
- 2x6 Mac Thunderbolt interface
- Record and mix with stunning 24/192 kHz audio conversion
- 24/192 kHz audio conversion
- Mic preamp emulations, powered by Unison™ technology
- High-speed Thunderbolt connection to your Mac
- Includes "Realtime Analogue Classics" UAD plug-in bundle
- 2 mic/line preamps; 2 line outputs
- Available in SOLO (one SHARC) or DUO (two SHARCs) configurations



Description	Code	Price (Ex VAT)
Apollo Twin Solo	328-910	£415.83
Apollo Twin Duo	328-920	£499.17

MOTU 16A

Thunderbolt Audio Interface



Provides industry-leading dynamic range and large console style mixing.

- Thunderbolt and USB2 interface with AVB capabilities
- 64 simultaneous audio channels
- 16 channels balanced TRS analogue I/O
- 2 x ADAT optical ports
- Easy expansion via ethernet CAT-5e
- On-board DSP with mixing and effects

MOTU 8M

Thunderbolt Audio Interface



Equally well-suited for studio and stage, with or without a computer, as an interface or standalone mixer.

- Thunderbolt and USB2 interface with AVB capabilities
- 50 simultaneous audio channels
- 8 XLR/TRS combo inputs with preamps and phantom power
- 8 balanced/un-balanced TRS outputs
- 2 x ADAT optical ports
- Easy expansion via ethernet CAT-5e
- On-board DSP with mixing and effects

Description	Code	Price (Ex VAT)
16A	375-660	£954.17
8M	375-650	£954.17

Focusrite Saffire Pro 26

FireWire/Thunderbolt Interface



Adds another highly flexible Firewire audio interface to the ever increasing range of Saffire series soundcards.

Focusrite Saffire Pro 26 features cross-platform operation combined with a comprehensive feature set and the best audio performance in its class, offering 24-bit 96 kHz audio capture. Saffire Pro 26 comes packed with numerous in/outs, including four pristine microphone preamps, and supports Thunderbolt ports via an optional Thunderbolt adaptor. Saffire PRO 26 offers true studio quality along with an impressive line-up of I/O, boasting 18 inputs and 8 outputs at 24-bit/96kHz resolution. Saffire Pro 26 features four mic preamps, two TRS instrument inputs, ADAT in (ideal for connecting an Octopre mic preamp when looking to expand analog input count), two independently controlled headphone outputs, 6 line outputs plus SPDIF digital I/O. In addition, front panel 5-segment LED input metering ensures clear input monitoring and JetPLL jitter-elimination technology maintains pristine audio quality in both analogue and digital domains. Saffire Pro 26 comes housed in a roadworthy chassis that connects to PC/Mac via the included FireWire 800 cable and Saffire Mix Control software makes this interface just as powerful in live situations as it is in the studio. Focusrite Saffire Pro 26 also ships with an excellent package of software tools to help you get your music down straight away. The latest version of the Focusrite Scarlett Plug-in Suite includes Compressor, Reverb, Gate and EQ in the form of VST/AU/RTAS plug-ins. Focusrite's established Xcite+ bundle is also included, which features Ableton Live Lite (for all your production, performance and compositional needs), Novation's Bass Station soft synth and over 1GB of royalty-free samples from Loopmasters.

Description	Code	Price (Ex VAT)
Saffire Pro 26	392-050	£232.50



MOTU 1248

Thunderbolt Audio Interface



Designed for studio recording, installed sound, and live sound reinforcement applications such as mixing a band in a club or music venue.

- Superb audio quality -123 dB dynamic range and -110 dB THD+N
- On-board DSP with mixing and effects
- Flexible 48-input digital mixer
- 12 stereo busses and DSP effects, inc reverb, 4-band EQ, gate, and compression
- Use the AVB Switch to network your 1248, 16A, 8M or other AVB-ready MOTU gear

Description	Code	Price (Ex VAT)
1248	375-640	£954.17
AVB Switch	375-670	£207.50

COMPUTER

Audio Interfaces/Sound Cards - Network

Focusrite RedNet Range

Audio Interfaces/Signal Distribution

Studio quality sound meets digital audio networking...

RedNet is Focusrite's flagship range of modular Ethernet-networked audio interfaces that harnesses the power of Audinate's tried and tested Dante digital audio networking system to bring studio quality sound to any modern audio application. Optional RedNet PCIe Card also available (Code 389-980). Email us for a quote or for more information.



Focusrite

Focusrite RedNet 1

Connects to your network with a single Ethernet cable

RedNet 1 is remotely controlled via the network and can be placed anywhere in your facility. It offers eight channels of line-level analogue in and out, with Focusrite's precision 24-bit A-D and D-A conversion for superb audio performance, and 119dB dynamic range at sample rates up to 192kHz. The rear panel includes standard DB25 connectors for analogue patchbay or breakout cable interfacing.

Focusrite RedNet 4

Adds eight of the latest remote-controlled Focusrite mic preamps / line inputs to your RedNet system.

With two selectable DI's, RedNet 4 provides an effective range of analogue inputs for your system. The unit includes Focusrite's world-class precision A-D conversion. Mic/Line/DI selection, gain, phantom power, HPF and metering are also accessible from the front panel. The benefit of remote control microphone pre-amp gain is that you can keep the mic pre close to the source.

Focusrite RedNet 2

Adds 16 remote-controlled analogue channels in and out to your RedNet network.

RedNet 2 can be located anywhere you can run an Ethernet cable. Featuring Focusrite's precision 24-bit A-D and D-A conversion for superb audio performance, it delivers 119dB dynamic range at sample rates up to 192kHz. The rear panel includes standard DB25 connectors for analogue patchbay or breakout cable interfacing.

Focusrite RedNet 5

Connects your RedNet system to Pro Tools HD®.

Up to six units can be connected to one Pro Tools HDX system, supporting up to 192 channels at 96 kHz or 96 channels at 192 kHz. Pro Tools HD® Native and Pro Tools HD® (TDM) are also supported. RedNet 5 is interoperable with other Pro Tools interfaces and no RedNet PCIe card is required.

Focusrite RedNet 3

Interfaces your existing digital audio systems and components to the RedNet network.

Features up to 32 inputs and outputs and full software remote control. The unit includes support for AES/EBU, S/PDIF and ADAT (16 ADAT optical ports support 32 digital channels in and out – even at 96kHz, with S-MUX2) digital audio formats and allows the RedNet system to be synchronised to incoming signal clock or a word clock source.

Focusrite RedNet 6

Allows multiple channels to be carried along a single interface.

RedNet 6 provides the link between your RedNet Ethernet-based audio system and any MADI / AES10 setup. RedNet 6 supports up to 64 channels of both coaxial and optical MADI interfaces and is completely bi-directional. RedNet 6 features an asynchronous sample rate converter (ASRC) on each input and output so you can interface between MADI and RedNet irrespective of the sample rate at which either system is operating. Connect your RedNet system to MADI-based digital consoles, computer cards, converters and much more. In addition to both coax and optical MADI interfaces, RedNet provides Word Clock in and out.

Description	Code	Price (Ex VAT)
RedNet 1	389-920	£1332.50
RedNet 2	389-930	£2040.83

Description	Code	Price (Ex VAT)
RedNet 3	389-940	£999.17
RedNet 4	389-950	£1540.83

Description	Code	Price (Ex VAT)
RedNet 5	389-960	£665.83
RedNet 6	389-970	£1332.50

SATURDAY DELIVERY
no problem

MORE PRODUCTS
online

DELIVERY BEFORE NOON
no problem

COMPUTER

Computer Monitoring

Studiospares M1000

Closed Type Monitor Headphones

Offers exceptionally accurate acoustic performance with a natural sound that's designed for studio monitoring and mixing.

A fantastic alternative to expensive branded studio headphones costing 2, 3 or even 4 times as much, the M1000 Monitor headphones enable critical listening for long studio sessions. Featuring a breathable protein leather earpad design for long-term comfort, detachable cable with screw-tight plugs, and 42mm neodymium driver units, the M1000s will not let you down no matter what your style of music. Impedance 64 ohms, frequency response 10Hz to 26kHz. Includes a spare pair of earpads and a 3.5mm to 6.3mm adaptor.



Description	Code	Price (Ex VAT)
M1000	448-760	£54.16
M1000 - 5 Pack	448-761	£243.00

COMPUTER monitoring

The speakers that come with your PC will be fine for bopping to 1D or JB, but when you want to get serious about making music, you need serious monitoring, either with dedicated monitor speakers or monitor headphones. Here are a few of our recommendations, or see the Headphones and Speakers section for more ideas.

If you need more information, please contact our technical sales team, who will be glad to help further.

Studiospares M2000

Open-Backed Mixing/Mastering Headphones



The M2000 is our new professional grade mastering headphone featuring an open-back design for improved accuracy at the expense of slightly reduced isolation. This design makes them well suited for mixing and mastering applications, where closed-back designs might restrict the accuracy of the response. Breathable protein leather ear pads designed for long-term comfort. Detachable cable with screw-tight plugs. 42mm neodymium driver units. Open-back design for highly accurate sound. Frequency response 10Hz to 26kHz. Impedance 64 ohms. Designed for professional mixing and mastering. Includes high quality 3.1 meter detachable screw-in cable, 3.5mm to 6.3mm (MiniJack to StereoJack) adapter, 2 x Spare ear pads, instruction booklet and soft carry case.

Description	Code	Price (Ex VAT)
M2000	448-780	£58.29

Studiospares Seiwin

Nearfield Monitors



Designed for studio use at the outset...

The Studiospares Seiwin active near field monitors are of exceptional quality and available at an extremely attractive price. They feature a 6", 80Watt bass driver and a 1", 40 watt soft domed tweeter. The cabinet is made from solid 17mm MDF which is covered in a black veneer. The Seiwin monitors have inputs on both Jack and XLR and volume and on/off switches are located on the back of each speaker.

Description	Code	Price (Ex VAT)
Seiwin - Pair	248-030	£132.50

Beyer DT100

Enclosed Studio Headphones

The best selling Studio headphones in history!

The Beyer DT100 gained this enviable reputation through their sound quality and solid construction. They are fully modular and we stock all component parts. The new soft foam ear pads provide an excellent seal against feedback. 400Ω impedance so can be connected to line level signals. Designed for extended use. Plug-in headphone lead.

Description	Code	Price (Ex VAT)
DT100 - Grey	410-001	£103.33
DT100 - Black	410-005	£103.33
DT100 - Grey 3-Pack	410-003	£290.83

KRK RP-5 G3

Studio Monitor

Studio standard for many of the world's finest engineers, producers and musicians.

- 5" Glass Aramid Composite Woofer
- 1" Neodymium Soft Dome Tweeter with Ferro Fluid
- Input: XLR (3-pin), RCA & 1/4" TRS - 10kΩ Balanced / Unbalanced
- 75 Watt Bi-amp Dynamic Power 18dB Octave Filters
- Frequency Response: 53Hz - 20kHz Video
- Dimensions: (H x W x D) 127.6cm x 18.5cm x 22.5cm



Description	Code	Price (Ex VAT)
RP-5 G3	390-210	£91.25
RP-5 G3 x2 + Monitor Pads	390-211	£185.00
RP-5 G3 x2 + Monitor Stands x2	390-212	£195.83

Adam A5X

Studio Monitor

Perfectly suited for all environments where space is limited but sound shouldn't be constricted.

- 2-way active bass reflex speaker
- 5.5" Carbon/Rohacell /Glass woofer with 50W X-A.R.T. Tweeter
- Stereolink pass of the second stereo channel to the other speaker
- Response: 50 Hz - 50 kHz
- Woofer amplifier 50W RMS
- Tweeter amplifier 50W RMS



Description	Code	Price (Ex VAT)
A5X Single	485-280	£227.50

Numark HF125

DJ Headphones

Quality DJ Headphones from one of the top names in DJ equipment.

- Enclosed design
- Flexible 7-position independently adjustable dual ear cups
- Large 40mm Mylar speaker drivers
- 6ft tangle-resistant cord with 1/4" connector
- Padded headband and ear cups.



Description	Code	Price (Ex VAT)
HF125	276-000	£5.78
HF125 - 6 Pack	276-006	£31.20

DELIVERY BEFORE 10AM no problem



beyerdynamic

COMPUTER

Digital Converters

Behringer Ultragrain Pro 8 ADA8000 Digital Converter



State-of-the art 8-channel A/D and D/A Converter...

The ADA8000 comes with 8 built-in IMP microphone preamplifiers. This ultra-compact 19" unit gives you the opportunity to connect analogue audio signals directly to a multitrack recorder or similar equipment via the integrated ADAT@ interface—and needs only one rack space for this purpose! In return, you can even connect the digital signal of a multitracker via ADAT@ to the eight analogue line outputs of your ADA8000.

Description	Code	Price (Ex VAT)
Ultragrain Pro 8 ADA8000	370-240	£112.50



Behringer Ultramatch Pro SRC2496

Digital Converter



The ULTRAMATCH PRO SRC2496 is the successor of the renowned SRC2000 and enables you to transfer digital audio signals between devices with different sample rates, formats or interfaces, disable SCMS for 1:1 digital copies and remove dropouts or jitter from digital media. Simultaneously operable outputs offer splitter functionality. The 24-bit/96kHz compatible SRC2496 now offers high-quality 24-bit/96kHz A/D and D/A conversion making it a useful tool around the recording studio. Format conversion between AES/EBU and SPDIF (coaxial or optical) is provided for, with high-quality signal output with 16-, 20- or 24-bit resolution. Universal sample rate synchronisation is done via wordclock or digital input. XLR, RCA and optical outputs are simultaneously operational with separately selectable inputs, turning this unit into a digital patch bay.

Description	Code	Price (Ex VAT)
SRC2496	370-220	£129.00

COMPUTER

MIDI Interfaces

E-MU XMIDI 2x2

USB MIDI Interface

A compact USB MIDI interface that provides two MIDI inputs and outputs.

- USB 1.1
- USB bus-powered
- 32 MIDI channels
- Ultra-fast MIDI response
- Active-sensing messages filtered
- MME, DirectMusic and CoreMIDI supported



Description	Code	Price (Ex VAT)
XMIDI 2x2	352-120	£35.00

ESI M4U XL

USB MIDI Interface



The useful M4U XL is a compact USB 2.0 MIDI Interface with 4 inputs and 4 outputs, perfectly optimized for usage with Windows Vista and Mac OS X. It's also fine for XP (no driver installation needed) and can be used directly in all current music applications. The compact 1/3 rack size box, USB bus power support and Plug-n-Play installation make M4U XL truly easy to use and easy to carry everywhere you go. Ideal for any studio environment with its 64 input MIDI channels and 64 output MIDI channels.

ESI M8U XL

USB MIDI Interface



The new ESI M8U XL offers maximum MIDI connectivity with 8 independent MIDI inputs and 8 independent MIDI outputs, providing 128 MIDI channels - all via a single USB 2.0 (or USB 1.1) connection to your PC or Mac. The convenient 1U sized unit provides 1 MIDI input and 1 MIDI output on the front for easy access, next to status LEDs for all MIDI I/O ports. All the other MIDI I/O connectors are on the back of the unit. True Plug-n-Play installation under Windows XP, Vista and Mac OS X, with no driver installation required, and fully class compliant, making it compatible with other operating systems eg Linux.

Description	Code	Price (Ex VAT)
M4U XL	224-210	£59.80
M8U XL	224-220	£127.00

IK iRig Pro

Guitar/Mic/MIDI Interface

Universal Audio-MIDI interface for iPhone, iPad and Mac.

- Balanced input for a mic, unbalanced input for line-level or Hi-Z source, via XLR/1/4" combo jack connector
- Preamp gain control
- High-quality mic and instrument preamp, low noise, high definition
- High-quality A/D conversion
- MIDI IN, compatible with iRig MIDI cables
- +48V phantom power provided by included 9V battery



NEW

Description	Code	Price (Ex VAT)
iRig Pro	321-720	£87.50

IK iRIG™ MIDI

Core MIDI Interface for iPhone/iPod Touch/iPad



Connects any MIDI compatible device to the iPhone®, iPod touch® and iPad®. iRig MIDI connects MIDI keyboards, drum machines, drum pads, pedal boards and more to an iOS device to control not only the included SampleTank but also a world of MIDI-compatible apps such as GarageBand®. You can also use iOS apps to control external MIDI equipment such as sound modules, DAWs or lighting systems right from the mobile device. iRig MIDI is the only compact iOS MIDI interface sporting 3 MIDI ports: IN/OUT/THRU.

Description	Code	Price (Ex VAT)
iRig MIDI	321-500	£65.00

M-Audio MIDISport 2x2

32 x 32 Channel MIDI Interface



One of the first to be equipped with the high speed USB connection suitable for use with USB-equipped PCs or Apples.

Extensive feature list includes MIDI-activity indicators for each port, MIDI Thru pushbutton so you can play your gear with the computer off without disconnecting, no computer disassembly required and it's self-powered. Nearly all recent PCs provide USB ports, which support the simultaneous connection of up to 127 devices; no tools are required for installation. Requires Windows 98 or later (not Windows 95). Lifetime warranty on this product.

Description	Code	Price (Ex VAT)
MIDISport 2x2	360-910	£33.32

1000s of products Available from stock!

DELIVERY BEFORE NOON no problem

MORE PRODUCTS online

iConnect MIDI1

MIDI Interface

Connects MIDI compatible controller, keyboard, synthesizer, or drum machine to a computer or iOS device.

- 1 in and 1 out set of MIDI DIN ports
- Supports 16 channels of MIDI I/O
- Mac and PC compatible
- USB bus powered. Plug and play - no drivers
- USB MIDI Class Compliant



iConnect MIDI2+

MIDI Interface

2 In & 2 Out Sets of MIDI DIN Connectivity.

- MultiHost Capability - Connect 2 Devices
- Audio passThru™ From One Device
- Integrated MIDI Manager inc Snapshot Preset
- 10 Ports of 16 Channels of MIDI I/O Per Port



iConnect MIDI4+

MIDI Interface

4 In & 4 Out Sets of MIDI DIN Connectivity.

- Supports 8 additional MIDI devices
- MultiHost Capability - Connect 3 Devices
- Supports Over 64 Ports of 16 Channels of MIDI I/O Per Port



Description	Code	Price (Ex VAT)
MIDI1	375-570	£57.50
MIDI2+	375-580	£65.83
MIDI4+	375-590	£165.83

COMPUTER

MIDI Controllers

Behringer B-Control Fader BCF2000

MIDI Controller

An innovative, hands-on control surface with ultra-precise 100mm motorised faders...

The ultimate control for virtual mixers, organ-drawbars, synths and samplers. You can make group moves that you can't make with a mouse—and the faders are motorised for automated control! The BCF2000 is USB compatible, features full MIDI In/Out/Thru capability and includes 8 endless rotary encoders, each with a 15-element LED indicator plus a push-to-set function, that let you select, adjust, set and control a myriad of functions. Assign a dedicated knob, fader or key to your most frequently used functions and make edits without touching the mouse. Tweak "front panel" settings by simply turning a knob or sliding a fader.



Description	Code	Price (Ex VAT)
BCF2000 Black	380-030	£160.00



Novation Launch Control XL

DJ Controller

NEW

The ultimate controller for Ableton Live.

- Tweak your sound using 24 knobs with multicoloured indicators
- Enhance your live performance by combining with Launchpad S
- Get precise control over your levels with eight rugged faders
- Plug straight into Mac, PC or iPad and start performing
- 16 buttons for immediate track focus and key mixer controls
- Includes Ableton Live Lite software and Loopmasters sample collection



Description	Code	Price (Ex VAT)
Launch Control XL	389-470	£133.32

Behringer B-Control Rotary BCR2000

MIDI Controller

Intuitive control with a real hands-on feel.

- 24 endless rotary encoders for the ultimate control of virtual synths, samplers, effects and signal processors
- USB compatible
- Full MIDI In/Out/Thru capability
- 4 endless rotary encoders, each with a 15-element LED indicator plus a push-to-set function



Description	Code	Price (Ex VAT)
BCR2000	380-040	£115.83

Behringer FCB1010

MIDI Foot Controller

Helps you get the most out of your gear without tying up your hands or slowing down your performance.

- 10 banks of presets
- 2 expression pedals with freely assignable MIDI channel, controller number and range
- MIDI note commands for trigger and tap-tempo applications
- Backup function via MIDI SysEx



Description	Code	Price (Ex VAT)
FCB1010	370-140	£95.00

Novation Launchpad S

DJ Controller

A powerful 64-button music controller that lets you make music or mix tracks using a super-intuitive grid of multi-colour buttons.



Launchpad S comes with Ableton Live music software (Launchpad Edition), used by some of the world's top DJs and producers – plus it supports other grid-based music applications such as FL Studio. Whether you're a DJ, performing musician or studio producer, Launchpad gives you all you need to 'play' your software straight out of the box. Use the 64-button grid to launch and manipulate clips, trigger loops, fire off effects, control your mixer – and much more.

Launchpad S also triggers loops and effects in the new Novation Launchpad app for iPad; a totally self-standing music performance app that hosts sounds and effects. Launchpad is totally portable. Hooked up to your computer – or iPad – via USB, it's fully bus powered (no need for power sockets), and it's lightweight and easy to carry anywhere.

Novation Launchpad S Control Pack

Launchpad S Control Pack is a combination of everything you need to make and perform electronic music with Ableton Live, containing Launchpad S, Launch Control, two custom made protective sleeves, Ableton Live Lite 9, and a large pack of inspiring Loopmasters samples.

Description	Code	Price (Ex VAT)
Launchpad S	389-410	£107.50
Launchpad S Control Pack	389-460	£165.83



Novation Launchpad Mini

Compact DJ Controller

NEW

Compact version of the celebrated Novation Launchpad.

- 64 three colour launch pads that let you play loops, sounds, effects and more
- Entirely bus-powered from your iPad, PC, or Mac
- Includes Ableton Live Lite, for your Mac or PC - plus the Launchpad App for iPad
- Includes a pre-loaded professional sound library
- Rugged and practical to withstand life on the road



Description	Code	Price (Ex VAT)
Launchpad Mini	389-450	£66.66

COMPUTER

MIDI Controllers

CONTINUED

Akai MPD18

MIDI Controller

The easiest way to add genuine MPC pads to your setup.

- Bank of 16 pads, velocity and pressure sensitive
- Three pad banks for a total of 48 sounds accessible from pads
- Q-Link assignable fader control
- MPC note repeat
- MIDI-over-USB interface
- USB powered, requires no AC adapter



Description	Code	Price (Ex VAT)
MPD18	265-830	£66.66

Arturia Minilab

USB Controller

A compact 25 note velocity sensitive keyboard with 16 Encoders and 16 Pads and Analogue Lab software.

- Pitchbend/Modulation touch strip
- Footswitch input. Recessed full sized USB jack
- Dimensions 373mm x 191mm x 50mm
- 5000 sounds from the best synths and key boards inc Modular V, CS-80V, Mini V, Arp 2600V, Jupiter 8V, Prophet V, Oberheim SEM V, and Wurlitzer V



Description	Code	Price (Ex VAT)
Minilab	221-020	£74.17

M Audio Trigger Finger Pro

USB Controller with Step Sequencer

Perform, produce, remix, and take command of any audio software with an array of hardware control.

- Includes M-Audio Arsenal and over 8GB of instruments and sample content
- Built-in step sequencer with standalone capability
- 16 RGB-illuminated pads
- Customizable, backlit controls with instant automapping
- Detachable, 3-position rugged metal stand
- USB-MIDI connection for Mac/PC



Description	Code	Price (Ex VAT)
Trigger Finger Pro	374-200	£162.50

NEW

COMPUTER

MIDI Keyboards

M Audio Oxygen 3rd Generation MIDI Keyboard Range



Perfect for composing on the go or performing live bass lines and pads, firing samples, or triggering audio and/or visual effects.

Featuring 25 keys with 4 octave transposition, the Oxygen 25 is a fully functional MIDI keyboard gives great action. The Oxygen 49 is a 49-key USB MIDI controller and it also features nine assignable sliders. The Oxygen 61 is a 61-key USB MIDI controller plus dedicated transport and track select buttons. The Oxygen 88 is a 88-Key USB MIDI Controller with graded hammer-action keyboard. Furthermore the Oxygen MIDI keyboards features eight MIDI assignable knobs to control any MIDI parameters you desire in your hardware or software, pitch and mod wheels, dual MIDI outputs one from keyboard, one from computer and keyboard doubles as elegant user interface. New features include full MIDI message support, plus 6 transport controls that can be reassigned to any MIDI parameter.

Description	Code	Price (Ex VAT)
Oxygen 25	373-380	£49.17
Oxygen 49	373-390	£82.50
Oxygen 61	373-400	£107.50
Oxygen 88	373-430	£274.17

This MIDI controller is powered via USB bus, batteries or DC adapter, and includes a Maximum Audio Tools software bundle.

M-AUDIO

Korg Taktile

USB Controller Keyboards

NEW



Loaded with functions that make it fun to play and use.

- A full array of DAW presets and basic functionality
- X/Y touch pad lets you create musical phrases within any plugin instantly
- Use the velocity-sensitive backlit trigger pads to easily enter chords or single notes
- Semi-weighted keyboard with a great playing feel
- X/Y touch pad can also be used as a track pad
- Stylish and ergonomic design
- A generous array of bundled software provides amazing value

Description	Code	Price (Ex VAT)
taktile 25 25-Note	283-300	£149.17
taktile 49 49-Note	283-310	£215.83

Korg Taktile Triton

USB Controller Keyboards

NEW



The sounds of Korg's best-selling TRITON music workstation.

- USB/MIDI controller with 512 built-in sounds
- Kaoss-style X-Y touch pad for creative control over effects and synths
- Velocity-sensitive pads to play notes and chords or trigger scene changes
- Includes presets for Live 9, Logic Pro X, Pro Tools 10, and other popular DAW software
- Includes Korg M1 LE virtual instrument software
- 25-Note or 49-Note

Description	Code	Price (Ex VAT)
taktile Triton 25 25-Note	283-320	£215.83
taktile Triton 49 49-Note	283-330	£282.50

WANT

a job?

Are you looking for a stable and rewarding career?

Studiospares are constantly expanding. We require additional staff for a variety of positions, working in a very congenial atmosphere. Practical experience of recording and/or live sound engineering would be preferable.

send in your CV in the first instance

PRICE

changes

This catalogue was priced on 1st December 2014.

Current prices may be higher...

see our website for up to date prices.

PDF

catalogue

Want this catalogue on your phone or laptop?

The Studiospares catalogue is now available in PDF format.

visit www.studiospares.com/page/pdfcatalogue!

M Audio Keystation 49es MK2

MIDI Keyboard

Easy-to-Use 49-Note USB Keyboard.

Featuring a 49-key, synth-action USB MIDI keyboard and the award-winning Key Rig software for the PC, Keystation 49es MK2 makes it easy to start composing and performing music with a computer.

Use Keystation 49es MK2 to play Key Rig's virtual instrument sounds, or audition loops and compose songs with M-Audio's Session, Apple's GarageBand, Ableton's Live Lite (included) or other music-creation programs. The Keystation 49es MK2 keyboard also includes professional features like pitch and mod wheels, an assignable volume slider, octave +/- buttons and sustain pedal input. It's powered via a single USB cable and works instantly with computers running Mac OS X or Windows XP.



Turns your Mac or PC into a versatile keyboard workstation!

Description	Code	Price (Ex VAT)
Keystation 49es MK2	373-140	£66.66

M-AUDIO

Alesis QX Series

USB MIDI Controllers



USB and MIDI Keyboard Controllers with assignable faders, pads and knobs.

- 25, 49 and 61-key keyboard controller with velocity-sensitive keys and modulation and pitch-bend wheels
- Assignable control surface features 8 faders, 4 trigger pads, 8 knobs and 6 buttons
- USB-MIDI and traditional MIDI for use with Mac and PC, as well as MIDI hardware
- Works with iPad via Apple USB Adaptor (not included)
- Includes Ableton Live Lite Alesis Edition software

Alesis V Series

USB MIDI Controllers



Combine velocity-sensitive keys with eight drum/trigger pads, allowing virtual instruments to be played with dynamic expression.

- Full size, flat-front keys (25, 49, or 61)
- Pitch Bend and Modulation Wheels
- 8 Pads with blue LED illumination
- 4 Assignable knobs and buttons
- Sustain pedal input
- Octave shift keys

M Audio Axiom

USB MIDI Keyboard Series



25-Key Semi-Weighted USB MIDI Keyboard and Controller.

- Control surface featuring smooth rotary encoders and mixer-style faders
- Angled top panel and backlit LCD screen
- Automatically map onboard controls to DAW mixer parameters with DirectLink mode

Description	Code	Price (Ex VAT)
QX25 25-Note	385-800	£65.83
QX49 49-Note	385-650	£83.32
QX61 61-Note	385-820	£115.83

Description	Code	Price (Ex VAT)
V25 25-Note	395-240	£54.16
V49 49-Note	395-250	£70.82
V61 61-Note	395-260	£99.99

Model	Description	Code
Axiom 25	25-Note Keyboard	363-850
Axiom 49	49-Note Keyboard	363-860
Axiom 61	61-Note Keyboard	363-870

Description	Code	Price (Ex VAT)
Axiom 25	363-850	£107.50
Axiom 49	363-860	£140.83
Axiom 61	363-870	£190.83

Alesis Q Series

USB/MIDI Keyboard Controller



Keyboard controllers that work with virtually all music software and MIDI hardware devices.

These compact controllers feature USB-MIDI and traditional MIDI jacks for easy connection to Mac, PC and MIDI hardware. Provide keyboard players with a full compliment of controls including pitch and modulation wheels, octave up and down buttons, an assignable data slider, and the ability to send program changes from the keys. Velocity sensitive keys for expressive, musical performance. Ableton Live Lite Alesis Edition for recording, sequencing, performing, artefacts. Analyse and scope your audio with advanced diagnostic tools, including a full-screen real-time FFT display and spectrogram "waterfall" display.

Description	Code	Price (Ex VAT)
Q25 25-Note Keyboard	385-640	£45.82
Q49 49-Note Keyboard	385-540	£58.32

ALESIS

IK iRig Keys Pro

MIDI Keyboard



Universal mobile keyboard for iPhone, iPad and iPod touch.

- 37 velocity-sensitive full-sized keys (a 3 full octaves range plus one note)
- Modulation and pitch bend wheels
- Volume/Data knob (assignable)
- Octave/Program Up/Down back-lit, soft-touch buttons
- SET button to store and recall 4 different customized setups
- Input for an optional sustain or expression pedal
- Core MIDI (iOS) and USB class compliant (Mac/PC)
- Includes Lightning, 30-pin and USB cables

Description	Code	Price (Ex VAT)
IK iRig Keys Pro	321-780	£90.83
IK iRig Keys Pro Bag	321-781	£32.50
IK iRig Keys with Lightning	321-790	£74.99

ALL PRICES EXCLUSIVE OF VAT.

COMPUTER

MIDI Keyboards

CONTINUED

Novation Launchkey

USB MIDI Keyboard Range



A range of 25, 49 and 61 note keyboard controllers with up to 50 physical controls including 16 velocity-sensitive multi-colour launch pads that trigger and stop clips.

Integrated software/hardware instrument with apps for Mac, PC and iPad. 'InControl' technology connects hardware controls directly to all major DAWs. 16 velocity-sensitive multi-colour launch pads. Professional synth-styled keyboard with over 50 hardware controls. Instant access to major DAW control parameters – with no assignment necessary. Includes one gigabyte Loopmasters sample pack and Ableton Live Lite.

Description	Code	Price (Ex VAT)
Launchkey 25 - 25-Note	389-380	£82.50
Launchkey 49 - 49-Note	389-390	£116.66
Launchkey 61 - 61-Note	389-400	£133.32



Novation Launchkey Mini

Mini-Key Instrument/Controller



Compact and portable, Launchkey Mini is great for producing and performing at home or on stage.

Launchkey Mini is an exciting new compact mini-key instrument/controller featuring 16 velocity sensitive, three colour illuminated launch pads - use them to launch loops, sounds, effects, transport controls, and more. It features a 25-note keyboard, eight assignable rotary controls, seven function buttons, and a further two performance buttons.

Description	Code	Price (Ex VAT)
Launchkey Mini	389-430	£66.66

M Audio Keystation Mini 32

Mini Keyboard



The M-Audio® Keystation Mini 32 is the ideal choice for players on the go.

- Delivers great playability in a small form factor
- Perform two-hand parts with 32 great-feeling, low-profile minikkeys
- Customize the keyboard sensitivity to your playing style with highly musical velocity curves
- Four assignable controls, including a rotary knob
- USB bus power and plug-and-play functionality

Description	Code	Price (Ex VAT)
Keystation Mini 32	374-040	£32.50

M Audio Keystation 61ES

USB Keyboard



With velocity-sensitive and semi-weighted keys, the 61ES is designed to easily integrate in any computer music environment.

- Pitch and modulation wheels with volume/control slider
- Separate MIDI out jack
- Powered via USB or 9VDC power adapter (sold separately)
- Mac OS X, Windows XP, and Vista class-compliant for plug-and-play
- Includes Ableton Live Lite

Description	Code	Price (Ex VAT)
61ES	363-590	£91.66

Akai Synth Station 49

49-Note Controller

A powerful keyboard controller for iPad devices.

- Portable, velocity-sensitive keyboard with pitch and modulation wheels
- 9 velocity-sensitive MPC-style drum pads
- Dedicated transport control buttons
- Built-in, adjustable dock charges your iPad/iPad2 while positioning the screen at the perfect angle



NEW LOWER PRICE

Description	Code	Price (Ex VAT)
Synth Station 49	265-970	£82.50

Akai Max 25

Controller Keyboard

Places revolutionary control at your fingertips with the ability to command anything, from vintage analogue synths via its CV/Gate outputs to modern MIDI and USB MIDI devices.

- 25 semi-weighted keys with aftertouch
- 4 backlit LED touch faders
- CV & Gate outputs for vintage analogue synths
- Built-in step sequencer for track construction



Description	Code	Price (Ex VAT)
MAX 25	265-990	£207.50

Akai MPK Mini MkII

25 Mini-Key Controller

Lets you record, compose, and perform with virtual instruments, effect plugins, and DAWs.

- 25 velocity-sensitive synth-action keys
- 4-way thumbstick for dynamic pitch and modulation manipulation
- 8 backlit velocity-sensitive MPC-style pads
- 8 assignable Q-Link knobs
- Four memory banks
- Onboard arpeggiator with adjustable resolution and modes
- Comes bundled with professional production software
- Octave Up and Down buttons



NEW

Description	Code	Price (Ex VAT)
MPK Mini MkII	265-950	£65.83

Akai LPK25

Laptop Performance Keyboard



A USB-MIDI controller for musicians, producers, DJs and other music creators.

- 25 velocity-sensitive mini-keyboard keys
- Arpeggiator, sustain button, octave up and down, and tap tempo controls
- Plug-and-play USB connection for Mac and PC
- Small enough to fit in a backpack or laptop bag
- Four programmable memory banks

Description	Code	Price (Ex VAT)
LPK25	265-870	£29.16

1000s
of products
Available from stock!

Roland A-49

MIDI Keyboard Controller



The A-49 is a dream for musicians seeking a simple, easy-to-use MIDI keyboard with pro-quality playing feel.

- Premium-grade, full-size keyboard
- X49 full-size keys with velocity sensitivity
- Lightweight, compact and easy to use
- Two knobs, two switches, and D-BEAM controller
- USB bus powered; no AC adapter required
- Bundled with Cakewalk SONAR LE software

Description	Code	Price (Ex VAT)
A-49 Black	309-900	£115.83
A-49 White	309-901	£115.83

Alesis VI Series

USB MIDIPad/Keyboard Controllers



Velocity-sensitive semi-weighted keys with aftertouch.

- Octave Up/Down buttons for the full melodic range
- Play bass lines, chords, and melodies
- 24 assignable buttons for manipulating effect plugins
- Virtual instruments: open and close filters, adjust volume levels
- Activate effects, tweak parameters, and more
- 16 velocity-sensitive RGB trigger pads
- MIDI Out to control external MIDI modules and synthesizers
- Bundled with Ableton Live Lite and Xpand!2 by AIR Music Tech

Description	Code	Price (Ex VAT)
VI25 25-Keys	395-210	£99.99
VI49 49-Keys	395-220	£133.32
VI61 61-Keys	395-230	£166.66

COMPUTER

MIDI Keyboards/Audio Interfaces

Behringer UMX Series

USB/MIDI Controller Keyboard



The Ultimate Studio in a Box: USB/MIDI Controller Keyboard with USB Audio Interface!

An ultra-compact USB/MIDI full size, velocity-sensitive keyboard and an innovative audio interface for recording and playback on your Mac/PC. The UMX250 has 25 keys, the UMX490 has 49 keys and the UMX610 has 61 keys. These keyboards also feature 10 programmable MIDI controllers plus 8 user-set buttons, music production software and a software sound module this is a studio in a box. Fantastic features and build quality and at these prices incredible value for money.

Description	Code	Price (Ex VAT)
UMX250	382-760	£74.17
UMX490	382-770	£90.83
UMX610	382-780	£104.17

COMPUTER

Synthesizers

Novation Bass Station II

Synthesizer

An analogue mono-synth based on the classic original Bass Station but re-worked for the 21st century.

- 25 full sized velocity sensitive keys with assignable aftertouch.
- Each key is individually sprung
- Includes 64 killer factory presets plus space for 64 other sounds
- Class compliant MIDI device with MIDI I/O
- "Acid" filter joins the "Classic" original Bass Station filter



Description	Code	Price (Ex VAT)
Bass Station II	389-420	£307.50

Moog Sub Phatty

Synthesizer

Moog's classic design plugs you straight into the analogue heart of this powerful new instrument, the grittiest Moog Synth ever.

- 25 full-size synth action keys, 16 presets with panel mode, and a 31 knob front panel
- Sound Sources: 2 Variable Waveshape Oscillators, 1 Square Wave Sub Oscillator, 1 Noise Generator
- Filter: Moog Ladder Filter 20Hz-20Khz
- CV/Gate Inputs: Filter CV, Pitch CV, Volume CV, KB Gate



Description	Code	Price (Ex VAT)
Sub Phatty	235-120	£590.83

Novation Mininova

Synthesizer



MiniNova is a compact, super-cool performance synth with the same sound engine as its big brother: the UltraNova.

- 256 incredible onboard sounds with 5 knobs for tweaking
- "Animate" sound with 8 back-lit buttons
- Brand new VocalTune and classic vocoder effects
- Comes with editing software and a software patch librarian
- 37 key controller keyboard with MIDI I/O

Description	Code	Price (Ex VAT)
Mininova	389-370	£224.17

Arturia Minibrute

Synthesizer



A revolutionary new analogue synthesizer from Arturia. Featuring a pure analogue signal path and a host of unique features, it sets a new standard for what a hardware synthesiser should be.

Description	Code	Price (Ex VAT)
Minibrute	219-390	£340.83

Roland System 1

Plug Out Synthesizer



Controls plug-in versions of now legendary Roland synths.

- Four oscillators for buckets of fat synth tones
- Parameters controllable with knobs and sliders with LED indicators
- Advanced Arpeggiator with SCATTER
- SCATTER jog dial offers 10 different phrase variations
- Dynamic, real-time control over 10 stages of depth
- -12dB and -24dB filter types with independent high pass filters



Description	Code	Price (Ex VAT)
System 1	319-130	£412.50

Roland TB-3

Touch Bassline Synthesizer



Packed with 134 sounds that live and breathe.

- 134 captivating sounds including 4 oscillator effects-processed tones
- Pressure sensitive Touch Pad
- Dedicated Tempo control with Shuffle and Tap Tempo
- Control built-in effects with smooth, responsive knobs
- 7 segment, 3 character LED display
- Seamless switch between pattern creation and performance
- 16-step indicator lights to aid in pattern creation
- Pattern support for up to 32 steps
- Easy access to Shuffle control



Description	Code	Price (Ex VAT)
TB-3	319-140	£204.17

PRICE changes

This catalogue was priced on 1st December 2014.

Current prices may be higher...

see our website for up to date prices.

PDF catalogue

Want this catalogue on your phone or laptop?

The Studiospares catalogue is now available in PDF format.

visit www.studiospares.com/page/pdfcatalogue!

COMPUTER

Samplers

Akai MPC Renaissance

Sampler

The MPC Renaissance is an unrivaled instrument for music production.

- 16 backlit genuine MPC pads and 16 Q-Link controls
- Classic MPC Note Repeat, MPC Swing and MPC transport controls
- MPC SOFTWARE for Mac or PC with 128-track sequencing capability
- Four-channel USB 2.0 audio interface and two-port USB 2.0 hub built in



Description	Code	Price (Ex VAT)
MPC Renaissance	265-730	£624.17

Akai MPX8

Pad Controller

A standalone SD sample launcher with MPC pads.

- Add mono or stereo samples via SD card
- 8 velocity and pressure-sensitive pads
- USB MIDI plus standard MIDI I/O
- Controls computer MIDI software and out board MIDI gear
- Drag-and-drop sample kit editor for Mac/PC
- Built-in library of popular sounds/samples
- Tune, add reverb, and save sample sets
- 2x Balanced 1/4-inch outputs
- Mini Jack headphone output (3.5mm)



Description	Code	Price (Ex VAT)
MPX8	265-980	£65.83

Roland SP-404 SX

Sampler

Powerful performance sampler with 12 pads and 3 knobs.

- Sample anytime, anywhere with built in mic and battery power
- 29 DSP effects with seamless effects switching
- Pattern sequencer with quantize and shuffle
- 1GB SD included, explainable to 32GB
- Import files from computer and assign samples to pads
- Fast, fun hands-on sampler for DJs, producers and engineers.



Description	Code	Price (Ex VAT)
SP-404 SX	309-190	£299.17

COMPUTER

Sound Modules

Korg Monotron DUO

Analogue Ribbon Synthesiser

Korg puts the thrill of the analogue synthesiser into everyone's hands with the new monotron DUO.

- Battery-powered and palm-sized analogue synthesiser
- Dual Oscillator for more advanced sounds



Korg Monotron Delay

Analogue Ribbon Synthesiser

As above, but features a Space Delay that can produce intense, analogue-like echo effects.

Description	Code	Price (Ex VAT)
Monotron Duo	283-150	£28.50
Monotron Delay	283-160	£32.50

Roland TR-8

Rhythm Performer

Every control has a solid, predictable feel with each drum instrument having robust, "playable" faders.

- Illuminated knobs and RGB-lit buttons
- Control variations in your patterns and any incoming external signal
- Reverse, glitch, gate, truncate, stutter and perform rhythmic variations
- 10 different types of Scatter and adjust the intensity or 'Scatter Depth'
- Realtime pattern creation up to 32 steps



Description	Code	Price (Ex VAT)
TR-8	319-150	£332.50

Roland VT-3

Voice Transformer

Easy voice transformation with vocoder, lo-fi effects, and synths you can sing.

- Tempo control knob and a Fine adjustment knob for total tempo control
- 16-step sequencer to switch between [A] and [B] and continuous playback
- Play drum instruments and record to steps in real-time
- Pattern creation up to 32 steps
- 8 Rec/Play modes
- Realtime play of 4 different types of rolls
- 7 segment, 4 character LED display



Description	Code	Price (Ex VAT)
VT-3	319-160	£132.50

COMPUTER

Audio Converters

Zoom TAC-2

Thunderbolt Audio Converter

Lightweight and portable, yet rugged enough for the road.

- Uses the latest Thunderbolt™ technology for ultra-low latency and the ultimate in high-quality audio, up to 24-bit/192kHz
- 2-in/2-out high speed Thunderbolt™ audio interface
- Two combo balanced XLR/TRS input connectors
- +48V phantom power for each input
- 7-position LED metering
- Burr Brown mic preamps with up to +60dB of amplification



Description	Code	Price (Ex VAT)
TAC-2	377-930	£274.17

COMPUTER

General Interfaces

IK iRing

iOS Motion Controller

Uses patented advanced image-recognition, motion control and precise geometric positioning technology.

- A simple double sided ring that fits comfortably between your fingers
- On one side is a linear pattern of 3 dots, on the other a triangular pattern
- Control your music apps and effects without touching device
- Motion controller for iPhone, iPad and iPod touch



Description	Code	Price (Ex VAT)
iRing Green	321-740	£14.99
iRing Silver	321-741	£14.99
iRing White	321-742	£14.99

COMPUTER

External Hard Drives

Verbatim External Hard Drives

USB

These palm sized USB portable Hard Drives are light weight making them easy to carry with you.

- Stylish smooth design
- Weigh only 150 grams
- USB bus powered
- Nero Backitup 2 essentials software included
- 4 storage capacities available
- Plug 'n' play



Description	Code	Price (Ex VAT)
3.5" 500GB USB 2.0	128-740	£73.06
3.5" 1000GB USB 2.0	128-750	£115.10
2.5" 1000GB USB 2.0	128-790	£99.70
2.5" 500GB USB 3.0	128-780	£55.00

WANT a job?

Are you looking for a stable and rewarding career?

Studiospares are constantly expanding. We require additional staff for a variety of positions, working in a very congenial atmosphere. Practical experience of recording and/or live sound engineering would be preferable.

send in your CV in the first instance

THE website

Keep up to date with all the latest products and current prices on the Studiospares website!

check out www.studiospares.com

MORE PRODUCTS online

COMPUTER

Computer Accessories

Art M-Connect

USB MIDI Cable

For connection of any MIDI device to your computer.

- USB interface for any MIDI device
- Separate MIDI In and Out cables
- Moulded cable ends indicate cable function
- LED indicators for power and MIDI In and Out
- Plug and play with Windows and Mac OS



Art T-Connect

USB MIDI Cable

The T-Connect is a low cost instrument to USB interface. USB recording for any electrified musical instrument with high quality 16-bit, 44.1kHz or 48 kHz digital audio interface.

Art X-Connect

USB MIDI Cable

A simple and affordable microphone to USB interface. USB recording for any dynamic mic with a high quality 16-bit, 44.1kHz or 48 kHz digital audio interface.

Description	Code	Price (Ex VAT)
M-Connect	325-940	£20.82
T-Connect	325-950	£24.99
X-Connect	325-960	£24.99

Studiospares Laptop Stand Premium

Laptop Stand



Easily erected with no loose parts to misplace. Aluminium alloy makes it light and strong. Shelf takes accessories keeping your desktop clear. Laptop dimensions 350mm x 274mm. Shelf dimensions 203mm x 120mm. Height adjustable from 320mm - 435mm. Colour White.

Description	Code	Price (Ex VAT)
Laptop Stand Premium	449-510	£20.79

Studiospares LS100

Floorstanding Laptop Stand

Laptop is clamped to its tray without covering ports, DVD drive trays and expansion slots. Height and tilt adjustable.

- Height adjustable between 610 - 1120mm
- Tray dimensions 400mm x 300mm
- Mouse tray dimensions 165mm x 200mm
- Two holders can be adjusted in width and depth to securely anchor any sized laptop



Description	Code	Price (Ex VAT)
LS100	449-550	£38.30

Studiospares XLR To USB Converter

MIC Preamp Converter

Simply adapts any condenser or dynamic microphone for USB inputs.

- Interfaces with Windows and Mac OSX
- No driver software necessary
- Adjustable mic gain control
- Adjustable headphone output
- 48V phantom power AND Phantom off switch
- 16-bit A/D converter
- 44.1kHz/48kHz sampling rate



Description	Code	Price (Ex VAT)
XLR to USB Converter	449-470	£28.30

COMPUTER

Computer Software

Toontrak EZ Drummer

Computer Software

A multi-microphone drum sampler designed for musicians and producers in need of a compact, affordable, easy to handle plug-in.

- Extensive drag and drop MIDI library (featuring 8000+ MIDI files)
- Users can control mic bleeding and levels between drums using the internal mixer
- Stereo and multitrack routing into the host through one single plug-in
- 7000 sound files at 16-bit/44.1kHz
- TPC II reduces system requirements to a minimum
- Operates in General MIDI



Description	Code	Price (Ex VAT)
EZ Drummer	224-310	£72.80

Steinberg Cubase 7
Computer Software

The most advanced music production system today.

Steinberg Cubase 7 gives you advanced multitrack editing tools, a new take-comping system and a revolutionary approach to MIDI form the center of a next-generation production environment, while the refined new interface gives faster access and more intuitive control than ever before. Inspiring VST3 effects and instruments like VST Amp Rack and LoopMash 2 fuel your creative imagination. Cubase 7 redefines music production software to offer a new composition and production experience that takes you to new horizons and beyond. An outstanding range of effect processors and superior instruments empower creative imagination to bring out the best in you. That's why Cubase is the choice of countless musicians and producers around the world.



Description	Code	Price (Ex VAT)
Cubase 7	366-020	£406.67
Cubase 7 Academic*	366-025	£236.67

Cubase Artist 7

Tailored to creative artists looking to combine the newest technologies with a vast range of musical features, Cubase Artist 7 is more than simply a DAW engineered to the highest standards. The new VST Amp Rack plug-in includes an array of mind-blowing amp emulations while the HALion Sonic SE and LoopMash 2 virtual instruments make easy way for song writing and meddling with loops. Enhanced usability due to the brand-new take-comping system, its commendable user interface, Windows and Mac 64-bit support and many other refinements make Cubase Artist 7 the perfect choice for talented newcomers and seasoned musicians.

Description	Code	Price (Ex VAT)
Cubase Artist 7	366-030	£203.33
Cubase Artist 7 Academic*	366-035	£121.67



Cubase Elements 7

An entry-level Cubase package for music recording and production. 32-bit floating-point audio engine with flexible routing and fully automatic delay compensation Supports up to 64 MIDI and 48 audio tracks simultaneously in DVD quality (24-bit/96 Hz). Includes outstanding virtual instruments: HALion Sonic SE workstation, MPC-style Groove Agent ONE drum machine, Prologue synthesizer. Comes ready with 33 audio effect processors, including PitchCorrect for vocal intonation correction and the great-sounding AmpSimulator. Cross-platform 32-/64-bit for Windows and Mac OS X Intel.

Description	Code	Price (Ex VAT)
Cubase Elements 7	365-980	£68.00
Cubase Elements 7 Academic*	365-985	£45.00

*These codes and prices are only available to genuine educational establishments on receipt of an official purchase order.

Computer Software

COMPUTER

CONTINUED

Propellerhead Reason v6

Computer Software

THE software synthesis studio that everyone has been raving about...

Reason is a complete virtual studio rack with all the tools and instruments you need to turn your ideas into music. You get synths, samplers, drum machines, loop players, mixers, effects, pattern sequencers and more—and as many iterations of each as your computer can handle. Use it as a stand-alone system with integral sequencer, a sub-system for other music software or just as a rack of great MIDI modules. Reason is so intuitive that you'll learn it in minutes, yet deep enough to let you develop your own unique musical blend.

"A piece of superbly designed and perfectly realized software... If you don't at least try this beautifully conceived, lovingly created and expertly implemented piece of music software history, you are really missing out."

Computer Music

Description	Code	Price (Ex VAT)
Propellerhead Reason v6	365-130	£290.83
Propellerhead Reason Strings Refill	365-120	£56.16
Propellerhead Reason Essentials	365-990	£82.50
Propellerhead Recycle	365-060	£125.53



Sibelius 7.5

Computer Software

Delivers revolutionary, time-saving features like Magnetic Layout and Dynamic Parts.

- Powerful creative toolset including Flexi-time MIDI input, Keyboard and Fretboard windows
- Gives you complete control over and customisation of the rhythmic feel of any individual part
- 7.5 can now better interpret such notation distinctions as tempo markings, metric emphasis and breath marks on playback



NEW

Sibelius First

Computer Software

Avid Sibelius® First is the fastest, smartest, easiest way for everyone to start to write and share music—from aspiring composers and songwriters, to teachers and students. Even if you're more comfortable playing instruments than using notation software, the intuitive interface will guide your songwriting process.

Description	Code	Price (Ex VAT)
Sibelius 7.5	371-000	£332.50
Sibelius First	371-070	£82.50
Sibelius 7.5 Academic*	371-100	£152.50

*These codes and prices are only available to genuine educational establishments on receipt of an official purchase order.

NEW

MORE PRODUCTS
online

Image Line FL Studio 11 Fruity Loops Edition

Computer Software

This complete virtual studio with fast, easy, powerful editing and processing.

- FL Synthmaker, fully modular environment
- One-click-recording using Edison wave editor plugin
- Features Slicex, the powerhouse drumloop slicer & re-arranging tool
- Fruity Limiter for maximising & compressing final mixes
- Wave Candy, audio analysis and visualisation tool with Oscilloscope, Spectrum Analyzer and Peak Meter
- Rendering with improved latency compensation



Image Line FL Studio 11 Producer Edition

Computer Software

The Producer Edition of Fruity Loops is as the above edition but with full audio recording capabilities, i.e ASIO-in recording and full audiotracks with WAV form display. It also has envelope automation of all parameters in playlist and includes the Edison Wave Editor.

Description	Code	Price (Ex VAT)
Fruityloops	367-090	£57.50
Fruityloops - 5 Pack*	367-305	£165.83
Producer	367-170	£124.17
Producer - 5 Pack*	367-315	£332.50

*These codes and prices are only available to genuine educational establishments on receipt of an official purchase order.

AVID Pro Tools 11

Production Software

Powerful audio production software for recording, composing, editing, and mixing music and sound for picture.

Pro Tools 11 offers the most cutting edge composition, recording, editing and mixing of music in the latest update of the most widely used audio workstation in the music industry. Multiple audio file formats and bit depths can be used within the same session, without duplicating any of the raw files. Higher resolution sound than ever before is available as a result of 32-bit floating-point file format support. Pro Tools 11 is focused on efficiency as well as quality, with powerful but easy to use tools included as standard. Whether editing on a desktop, laptop or from an external hard drive, speed up the process with Smart Tools, Clip Gain and new AudioSuite workflows. Over 75 virtual instruments, effects, sound processors and utility plug-ins are included. Some of the plug-ins emulate the sounds of classic, revered hardware processors, amps and instruments, as well as the widely respected EQ and dynamics from the craved System 5 console.

Description	Code	Price (Ex VAT)
Pro Tools 11	373-940	£457.50
Pro Tools 11 Academic*	373-950	£199.17
Pro Tools 11 Student	373-955	£199.17

*These codes and prices are only available to genuine educational establishments on receipt of an official purchase order.



DELIVERY BEFORE NOON
no problem

SATURDAY DELIVERY
no problem

DELIVERY BEFORE 10AM
no problem



Studiospares S1970 Female Vocalist Microphone

Code 449-940 £57.50

The **S1970** is a great little vocal microphone, particularly suited to the warming female vocal tones of yesteryear. The Gold finish looks fantastic on stage, bringing a touch of class and upbeat nostalgia to any stage performance. With this in your arsenal, you'll be sure to have the crowd swinging right back to the Golden Summer of '69!

Adam
Sales Supervisor



Novation Bass Station II Analogue Synthesiser

Code 389-420 £307.50

Harking back to the original **Bass Station**, this unit is a solid choice for producers looking for more 'whoomph' in their wobble and more 'phatness' in the bottom end. But it's not all about the bass – this beast is easily at home firing out vicious lead melodies and Spandau pads.

Perry
Educational Sales

STAFF CHOICE

This **STAFF CHOICE** section highlights new and popular products our own sales and technical staff recommend from personal experience!



Studiospares M1000 Headphones

Code 448-760 £54.16

The Studiospares M1000 are the perfect addition for your ears and studio. These headphones offer exceptionally accurate acoustic performance and couldn't come at a better price!

James
Sales/Technical Advice

Allen & Heath QU-16 Digital Mixer



Code 269-580 £1415.83

Allen & Heath. Sensible Price. Need we say more?!

You can expect the usual Allen & Heath quality, at the most sensible price on the market for a digital console of this specification. It's loaded with all the effects and processors I need when mixing live. And they're so easy to use via the 800 x 480 colour touchscreen. The preamps sound amazing, but this is to be expected. I can also save my mixes and switch between them with the flick of a button. For the price... You cannot find better!

Jon
Sales/Technical Advice

UA Apollo Twin Duo Audio Interface

Code 328-920 £499.17

High grade preamps and monitoring combine with plugins that would have even the most hardened studio luddite working out the ebay value of their analogue outboard in the latest addition to Universal Audio's 'Apollo' series of interfaces. Fair warning – UAD plugins may force you to revisit all your previous mixes and 'digitally re-master' them! Plump for the duo version to avoid DSP overload woe.

Joel
Technical Manager



ART Pro MPA II Microphone Preamplifier

Code 325-530 £240.83

Budget valve equipment often suffers from noise problems problematic noise floor, and can often sound harsh or muddy even at normal working levels. The **ART Pro MPA II** is one of the very few valve products at the price to truly enhance the source. It's very versatile, going from clean to musically gritty. The impedance knob can definitely shape the response of dynamic and especially ribbon microphones. A genuine workhorse, particularly at the price.

Pablo
Sales/Technical Advice

INDEX

Microphones	
Studio Condenser Mics	86
Valve Mics	94
USB Mics	95
Ribbon Mics	96
Smartphone/Tablet Mics	97
Instrument Mics	98
Drum Mic Kits	101
Modular Mics	103
Vocalist Mics	104
Broadcast Mics	110
Boundary Mics	111
Installation Mics	112
Stereo Mics	112
Lavalier Mics	113
Video Camera Mics	113
E.N.G. Reporting Mics	114
Highly Directional Mics	114
Measurement Mics	115
Headworn Mics	115
Speech Mics	116
Radiomics	116
In Ear Monitoring	124
Radiomic Accessories	124
Windshields	124
Pop Screens/Acoustics	125
Elastic Suspensions	128
Goosenecks	129
Mic Holders	131
Microphone Accessories	131
Phantom Power Supplies	132
Thread Adaptors	133
Mic Splitters/Combiners	133
Mic/Line Problem Solvers	134
Mic Transformers	135
Inline Attenuators	135
DI Boxes	136

MICROPHONES

Studio Condenser Microphones

Audio Technica AT4033 Cardioid

Condenser Microphone

The AT4033 offers low-noise, symmetrical, transformerless circuitry.

- Precision-machined, nickel-plated brass, acoustic element baffle
- 2-micron-thick gold diaphragm
- Floating-construction capsule assembly
- State-of-the-art surface-mount electronics
- Custom shock mount

Because of the 4033's extended low frequency response we include the elastic suspension in our pricing.



Description	Code	Price (Ex VAT)
AT4033A + Shockmount	404-840	£285.00
Stand Mount	450-180	£58.50
Windshield	700-240	£32.50

Studiospares S985

Cardioid Condenser Microphone

Nothing ever beats the sound of an Electret Capsule for capturing percussive sounds.

The smaller and hence the lighter the diaphragm the better. Inspired by the legendary AKG 451 the S900 captures the sizzle of the cymbal and crack of the tom tom. Thankfully the sound is not chromium plated or metallic. Conventional dynamic microphones sound as if you are listening through a door in comparison. The frequency response reveals why the sound is so smooth. It is ruler flat right through the 'difficult' 5kHz to 10kHz region where others exhibit 'presence peaks'. The response is +3dB from 50Hz to 19kHz and the maximum SPL is 148dB. The equivalent Noise Level is 18dB-A (IEC 268-4) A weighted. The low noise platform is attributed to the front end bipolar FETs.

Supplied complete with a bag, foam windshield and a microphone clip.

Description	Code	Price (Ex VAT)
S985	449-670	£290.83



AKG C214

Condenser Microphone

Features AKG's legendary 1" edge-terminated large diaphragm sound.

- Outstanding dynamic range (up to 156 dB SPL, ultra-low noise)
- Integrated suspension to reduce mechanical noise
- Switchable 20 dB attenuation pad and low cut switch
- Shock mount carrying case included



NEW

AKG C214 Package 1

Package containing the AKG C214 Microphone with our **Stonewall Microphone Filter**, a Professional **10m XLR Lead** and a **K&M Professional Microphone Stand**.

NEW

AKG C214 Package 2

Package containing the AKG C214 Condenser Microphone with our **Studiospares Microphone Stand** and a Professional **5m XLR Lead**.

Description	Code	Price (Ex VAT)
C214	439-800	£240.83
C214 Stereo Pair	439-920	£565.83
C214 Package 1	439-805	£262.50
C214 Package 2	439-806	£257.50

AKG C414 XLS

Condenser Microphone

Especially designed for recording of solo vocals and solo instruments.

- Cardioid pick up pattern
- A classic mic with a distinctive timbre
- High sound pressure level capability
- Immune to electro-magnetic interference
- Three switchable bass cut filters
- Three pre-attenuation pads
- Flat frequency response



AKG C414 XLS Matched Pair

The matched pairs consist of two microphones that are within 1dB to each other in sensitivity and also within 1dB to each other in the range of 300 Hz to 8,000 Hz. Huge cost savings.

AKG C414 XLII

The frequency response has a slight presence peak favouring individual vocalists and solo instruments when miked at a distance. Grille colour Gold.

Description	Code	Price (Ex VAT)
C414 XLS	409-841	£649.17
C414 XLS Matched Pair	700-927	£1415.83
C414 XLII	419-170	£799.17
C414 XLII Matched Pair	419-172	£1549.00

Studiospares S990

Cardioid Condenser Microphone

A multi application microphone that is equally at home with an orchestra, a band or a vocalist.

The back electret capsule provides an uncompromising sound through the response being held within very tight limits through the critical 500Hz - 10kHz range. The transient response is excellent mainly due to the 22mm diameter capsule which easily captures the zing of hi hats or the thud of a bass drum. Unusually the S990 includes a pad with three sensitivity options, 0, -10dB and -20dB. Maximum SPL is 142dB @ 1kHz. Sensitivity is -40dB ref 1 volt/pascal. Additionally a switched high pass filter cuts in below 80Hz at 12dB/octave to filter out unwanted high energy low frequencies. Powering is via the internal 9V PP3 battery or 24 - 48 volt phantom powering. This S990 is very versatile and represents astonishing value for money and would be difficult to fault whatever the application.

Supplied complete with a bag, foam windshield and a microphone clip.

Description	Code	Price (Ex VAT)
S990	449-120	£52.40



Behringer C2 Matched Pair

Condenser Microphone



The C-2s utilize a low-mass diaphragm for ultra-wide frequency response and ultimate sound reproduction and their inconspicuous size makes them perfect for acoustic instruments, overhead applications, pianos and similar. The cardioid pickup pattern effectively eliminates feedback, plus there is switchable low frequency roll-off and -10dB input attenuation. Ultra low-noise transformerless FET input eliminates low-frequency distortion, while a gold-plated 3-pin XLR connector assures the highest signal integrity. Custom microphone stand adaptors, windscreens, stereo-bar and transport case are all included.

Description	Code	Price (Ex VAT)
C2 Pair	381-160	£41.50

Behringer C3 Cardioid · Omni · Fig 8

Condenser Mi

Designed to capture sounds with incredible realism and accuracy.

- Ideal as main and support mic for studio and live applications
- Selectable cardioid, omnidirectional or figure eight pickup pattern
- Pressure-gradient transducer with shock-mounted dual-diaphragm capsule
- Flat frequency response and ultra-high sound resolution
- Ultra low-noise transformer less FET input eliminates distortion



NEW LOWER PRICE

Description	Code	Price (Ex VAT)
C3	381-150	£39.90

Behringer C1

Condenser Microphone

Condenser microphone designed to capture sounds with incredible realism, sensitivity and accuracy.

- Cardioid pickup pattern
- Pressure-gradient transducer with shock-mounted capsule
- Perfect for acoustic instruments, overhead, piano, etc.
- Flat frequency response and ultra-high sound resolution
- Ultra low-noise transformer less FET input eliminates distortion
- LED indicates phantom power operation



NEW LOWER PRICE

Description	Code	Price (Ex VAT)
C1	381-170	£27.50

Behringer C4 Matched Pair

Matched Single Diaphragm Condenser Microphones

These outstanding condenser mics are especially great for live applications.

- Sold as matched pair—perfect for stereophonic recording
- Low-mass diaphragm for ultra-wide frequency response
- Cardioid pickup pattern for effective feedback elimination
- Switchable low-frequency roll-off and -10dB input attenuation
- Includes Stand adaptors, stereo-bar, windscreens, and transport case



NEW LOWER PRICE

Description	Code	Price (Ex VAT)
C4 Pair	381-840	£34.50

Studiospares S2000

Cardioid + Omni + Fig. 8

The product of a long line of multi pattern condenser mics so benefits from an extended development programme.

A multiple pattern studio condenser microphone, the S2000 can easily handle the wide range of sound levels found in a studio. A dual capsule design with back to back 35mm Gold capsules operating via a VPM (Voltage Phase Matrix) which maintains a highly predictable polar pattern. The capsules are pre aged to ensure they maintain their tight tolerances for life not just for a few months. They are polarized by an elevated voltage which increases the output voltage which is reflected in the system noise which has reached a new low. Excessive SPLs are contained by switching in the -10dB attenuator. The front end design is based on a pair of JFETs which yield the lowest noise platform currently available. They also allow a wide overload margin allowing the S2000 to function without compromise in any situation within the recording studio, whether for instruments or vocalists.

Includes an elastic suspension and foam windshield.

Description	Code	Price (Ex VAT)
S2000	449-950	£79.17



NEW

Telefunken CU-29

Tube Condenser Microphone

Offers a warm, well-rounded low end accentuated by a delicate and intimate 'air' in the high end.

- Entirely devoid of the upper mid-range bite
- Single Sided Gold Sputtered Membrane
- Modern Power Supply, Shock Mount, Wooden Box, 7-pin Microphone Cable
- SPL 138 dB. Cardioid polar pattern



Description	Code	Price (Ex VAT)
CU-29	499-300	£899.00

Blue Bluebird Cardioid

Condenser Microphone

Designed for applications ranging from vocals and guitars to drums and percussion.

- Transducer type: Condenser, pressure gradient
- Cardioid polar pattern
- Frequency response of 20Hz –20kHz
- Output impedance of 50ohms
- Includes a metal mesh pop filter and specially designed shockmount
- Size: 222mm x 45mm



Description	Code	Price (Ex VAT)
Bluebird	424-550	£182.50

sE 2200A II

Cardioid Condenser Microphone

The SE2200 series remains their best selling microphone for the last 10 years.

These updated versions retain the same hand crafted 1" gold-sputtered diaphragm as the first generation sE2200a. The sE2200a II Cardioid features a low cut bass filter, 10dB pad and comes complete (for a limited period) with their new universal, black shockmount and an SE Metal Pop filter. The MK2 has been given a face lift with sE's custom black rubber paint finish, which is both stylish and practical, helping to damp chassis resonance. The equivalent Noise Level is 13.9dB-A and the Max SPL for THD 0.5% is 135dB. The Multi Pattern version includes Cardioid, Omni, Figure-8 polar patterns.

Description	Code	Price (Ex VAT)
2200A II Multi Pattern	422-390	£232.50
2200A II Cardioid	422-400	£165.83

**Behringer C4 Matched Pair**

Matched Single Diaphragm Condenser Microphones

These outstanding condenser mics are especially great for live applications.

- Sold as matched pair—perfect for stereophonic recording
- Low-mass diaphragm for ultra-wide frequency response
- Cardioid pickup pattern for effective feedback elimination
- Switchable low-frequency roll-off and -10dB input attenuation
- Includes Stand adaptors, stereo-bar, windscreens, and transport case



NEW LOWER PRICE

Description	Code	Price (Ex VAT)
C4 Pair	381-840	£34.50

Rode M5 Matched Pair

Condenser Microphones

Carefully selected to ensure a variation of no more than 1dB sensitivity between the mics.

- Half inch Electret cardioid capsule
- Proprietary ceramic coating provides a sleek matt black finish
- JFET impedance converter with bipolar output buffer; Maximum SPL 140dB
- Equivalent Noise Level 19dB-A
- Powering 24 or 48volts



Description	Code	Price (Ex VAT)
M5 Pair	497-100	£124.17

sE 1A Cardioid

Condenser Microphone

Retains the same capsule as the sE1, but combines this with all new, super-quiet electronics.

- Frequency response of 30Hz-20kHz
- Cardioid, diversity polar pattern
- Sensitivity of 10mV/Pa - 40 ± 2dB(0dB=1V/Pa 1000Hz)
- Requires 48V phantom power
- 3-pin connector



NEW LOWER PRICE

Description	Code	Price (Ex VAT)
1A	422-000	£82.50
1A Pair	422-120	£165.83

ALL PRICES EXCLUSIVE OF VAT.

MICROPHONES

Studio Condenser Microphones

CONTINUED

Rode NT5

Small Diaphragm Condenser Microphone

Suitable for a variety of applications where a flat frequency response and accuracy are of paramount importance.

The externally biased 1/2" Gold sputtered capsule delivers a smooth on axis frequency response with a reduced proximity effect. A JFET Impedance converter with a bipolar output provides a self noise as low as 16dbSPL (A weighted) and a dynamic range of 128dB with a maximum SPL of 143dB. The microphone body is fabricated from a heavy duty cast metal with a satin chrome finish. In comparison to transformer output stages the NT5's transformerless output stage drastically reduces low frequency distortion. Typical anticipated usage will be for drum overheads, acoustic instruments and vocals. Supplied complete with RM5 stand adaptor, WS5 windshield and carry case.

The **NT5 Matched Pair Bundle** includes Studiospares mic stand, stereo bar and 2x XLR leads. The **NT5 Matched Pair Pro Bundle** is similar but with Sabra dual mic support, heavy duty mic stand, and professional Neutrik/Sommer XLR leads. Amazing savings!

Description	Code	Price (Ex VAT)
NT5 Single microphone	417-180	£99.17
NT5 Matched Pair	417-110	£199.17
NT5 Matched Pair Bundle	417-115	£235.00
NT5 Matched Pair Pro Bundle	417-116	£340.83
NTRM5 Stand Mount	417-430	£15.41
WS5 Windshield	417-480	£15.41

Rode NT45-0

Interchangeable Capsule

Omnidirectional capsule for NT4/NT5/NT55/NT6. All NT45 series capsules offer low noise and high output, and can easily be fitted to the NT4, NT5, NT55 and NT6 mic systems by simply unscrewing the existing capsules. The NT45-0 has an omnidirectional polar response.

Description	Code	Price (Ex VAT)
NT45-0	417-220	£57.50





Rode M3 Cardioid

Condenser Mi

Extremely versatile microphone that is at home in the studio, on location, or wherever a wide-response cardioid condenser microphone is demanded.

- Low-noise wide-response cardioid condenser microphone
- Battery status LED
- High Pass Filter
- Included windshield and a stand mount
- Powered via 9V battery or 48V Phantom
- Bundle includes stand and Pro 5m lead



Description	Code	Price (Ex VAT)
M3	417-360	£57.50
M3 Bundle	417-365	£69.49

Rode NT4 Cardioid

Single Point Stereo Microphone

Solves the problem of stereo recording by eliminating the need to purchase matched pairs.

- Stereo X/Y condenser microphone
- Dual externally biased 1/2" capsules with gold sputtered diaphragm
- Capsules closely matched with full frequency response
- Dual power operation
- Custom stereo cables included
- Twin head windshield (WS4) included



Description	Code	Price (Ex VAT)
NT4	417-100	£282.50
NTRM3 Stand Mount	417-420	£15.41
WS4 Windshield	417-470	£15.41

MORE PRODUCTS
online

sE X1

Condenser Microphone

The X1 is a new benchmark in quality of build and performance at an incredible price.

- Large diaphragm condenser microphone
- Cardioid pickup pattern
- Hand crafted capsule
- 10dB pad and bass cut
- Hand built in sE's own facility in Shanghai
- High quality



sE X1 Vocal Pack

Microphone Pack

Pack includes sE X1 Condenser microphone, Metal Pop Filter, Shock Mount and an XLR-XLR 3m Microphone Cable

sE X1 Studio Bundle

Microphone Bundle Pack

Bundle includes sE X1 Condenser microphone with acoustic filter, shock mount, pop shield and 3m mic cable.

Description	Code	Price (Ex VAT)
X1	422-360	£95.83
X1 Vocal Pack	422-363	£104.17
X1 Studio Bundle	422-365	£149.17
X1 Shock22 Mkl Shockmount	422-369	£47.90

Rode NT2-A

Condenser Microphone

The NT2-A carries on the tradition forged by the legendary Rode NT2.

A professional large capsule (1") studio microphone incorporating three-position pick-up patterns, PAD and high pass filter switches conveniently located on the mic body, the NT2-A is at home on an incredibly diverse range of sound sources. The frequency and transient response of this transducer has been voiced to complement today's modern recording techniques, and yet still evoke the silky smooth character of the legendary microphones of the 50's and 60's. Three 3-position switches allow selection of cardioid, fig 8 or omni polar patterns. Flat response, 40Hz, 80Hz high-pass filters. - Pad adjustments of 0dB, -5dB or -10dB attenuation. Has a wide dynamic range and exceptionally low self-noise. Perfect for recording vocals and acoustic instruments. It has a rugged design and features a high-strength, heat-treated steel mesh head. With a durable, satin nickel finish.

Its superlative audio characteristics combined with the included SM6 shock mount with integrated pop filter, 3m (10') XLR cable and dustcover, make the NT2-A one of the most versatile condenser mics available.

Description	Code	Price (Ex VAT)
NT2A	417-010	£190.83
NT2A + RED 100	417-017	£240.83
NT2A + Mic Stand (Without Boom)	417-018	£195.00
NT2A + RED 50 + Mic Stand (Without Boom)	417-019	£215.83





Rode NT1 KIT

Condenser Microphone

An exceptionally quiet large 25mm capsule condenser mic.

- Cardioid polar pattern
- Silky vintage-voiced 1" HF6 capsule
- Integrated Rycote Lyre capsule mount
- Ultra low noise transformerless circuitry
- JFET impedance converter in front end
- Max SPL 132dB;
- Dynamic range 128dB
- Phantom powering 24 or 48 volts
- NT1 microphone available singly, with pouch and RM2 Mount



Description	Code	Price (Ex VAT)
NT1 Kit Black	497-090	£174.17
NT1 only + Pouch + RM2 Mount	497-091	£xx.xx

sE Magneto

Studio Condenser Microphone

The sE Electronics Magneto condenser microphone brings the rich heritage of high quality studio mics within reach for musicians on a budget.

- Frequency Response: 20-20 kHz
- Cardioid response with good rear rejection
- Max SPL for 0.5% THD @ 1000Hz: 140 dB
- Phantom Power 12-48V
- Includes a mic clip and thread adaptor



NEW

Description	Code	Price (Ex VAT)
Magneto Black	422-435	£65.83
Magneto Silver	422-430	£65.83

sE sE5

Small Diaphragm Condenser Microphone

Sets the new standard for small diaphragm microphones and is perfect for studio and live use.

- Ideal for recording drums, percussion, pianos and any stringed acoustic instrument
- Finished in matte black
- Cardioid polar pattern
- -10/-20db pad switches
- Frequency range: 20Hz - 20kHz
- Sensitivity: -34dBV/ Pa
- Rated impedance: 200 ohms
- Includes a custom shock mount



NEW

Description	Code	Price (Ex VAT)
sE5	422-440	£199.00
sE5 Pair	422-445	£399.00

Avantone CK1

Condenser Pencil Microphone

An FET true condenser mic with three interchangeable capsules, with body and capsule made of machined brass for durability.

- Cardioid, Hyper-Cardioid & Omni Capsules
- High-Pass Switch
- Attenuation Switch -10 dB for 138dB SPL
- Sensitivity 15mv/pa.
- Noise Floor < 17 dBA
- 48 volt phantom powering
- Includes a wooden box with shockmount



Description	Code	Price (Ex VAT)
CK1	413-630	£90.83

Rode NT1A

Cardioid Condenser Microphone

Very popular in school and college recording studios, the NT1A is a quality condenser mic that will take your recordings to a new level.

The design brief when developing the NT1 was to produce a microphone with the same sonic clarity as the NT2. Rode have accomplished this task with very little compromise; the same open warm sound produced by the NT2 is present with the NT1. An internal shock mount assembly holds the transducer which features a large 1" gold sputtered Milar diaphragm as used in the more expensive NT2. Two layers of high grade stainless steel have been used in the Head. The first is a strong open weave and the second is a fine weave providing excellent Pop screening. Transformerless FET circuitry generates very low self-noise, whilst the body of the microphone is precision machined and finished in a durable coating.

The NT1A Recording Pack now includes a studio grade pop shield and shock mount, a 20' mic cable, dust cover and an instructional DVD with recording tips.

Description	Code	Price (Ex VAT)
Rode NT1A Recording Pack	417-005	£115.83
Rode NT1A Matched Pair	417-250	£257.50
SM6 Elastic Suspension	417-050	£40.83
NTRM1 S1 Stand Mount	417-410	£15.41
WS2 Windshield	417-450	£22.49



BEST SELLER

Rode NT1A + RED 100/RED 50 Microphone Bundle

The Rode NT1A mics are famed for their flat frequency response and incredible accuracy. Combine this with the hugely popular RED 100 and RED 50 microphone filters, and the quality of any vocal recording will be simply exceptional. Save more than 15% when getting these great products together!

Description	Code	Price (Ex VAT)
NT1A + RED 100	417-007	£185.00
NT1A + RED 50 + Mic Stand (Without Boom)	417-009	£157.50
NT1A + Mic Stand (Without Boom)	417-008	£119.50



Audio Technica AT2031

Condenser Microphone

The ideal microphone for stringed instruments in both studio and live applications.

- Smooth, extended response with a slight rise in the high-frequency region
- Switchable 150Hz 6dB/oct hi-pass filter
- Cardioid polar pattern
- High SPL and wide dynamic range
- Ideal for violin, cello, acoustic guitar, harp and piano



Description	Code	Price (Ex VAT)
AT2031	447-700	£111.70

Audio Technica AT2020 Cardioid

Condenser Mi

The new standard for affordable side-address studio condensers.

- Ideal for project/home-studio applications
- High SPL handling and wide dynamic range
- Custom-engineered low-mass 16mm diaphragm
- Cardioid polar pattern
- Rugged construction for durability
- Includes pivoting, threaded stand mount
- Bundle includes stand and pop filter



Description	Code	Price (Ex VAT)
AT2020	447-070	£74.17
AT2020 Bundle	447-072	£88.70

Audio Technica AT2035 Cardioid

Condenser Microphone

This side-address cardioid studio condenser mic delivers exceptional detail and low noise designed for the home, project, professional studio.

- Large diaphragm for smooth, natural sound and low noise
- Switchable 80 Hz high-pass filter and 10 dB attenuation pad
- Custom shock mount
- Fixed-charge back plate, permanently polarized condenser



Description	Code	Price (Ex VAT)
AT2035	447-250	£132.50

WANT a job?

Are you looking for a stable and rewarding career?

Studiospares are constantly expanding. We require additional staff for a variety of positions, working in a very congenial atmosphere. Practical experience of recording and/or live sound engineering would be preferable.

send in your CV in the first instance

MICROPHONES

Studio Condenser Microphones

CONTINUED

AKG C1000S MKIV

Cardioid • Hypercardioid

Classic condenser mic found in practically every studio!

This updated version includes a PB1000 Presence Boost Adaptor which adds a presence boost to frequencies between 5kHz and 9kHz to provide a more "brilliant" sound. This gentle boost adds clarity and enables a vocalist to "cut through the mix". A PPC1000 adaptor changes the polar pattern to hypercardioid. The overall frequency response is from 30Hz-19kHz. The C1000S is designed as a versatile instrument microphone for any recording studio. Better separation for close miked drum kits is obtained by fitting the PPC1000 polar pattern adaptor over the capsule to make it's pick up hypercardioid. That configuration is particularly relevant in reducing feedback problems with the PA where the acoustics are lively. Powering by internal 9 volt battery or phantom powered from the mixer (9V-52V).

Supplied with W1000 External Windshield, SA43 Mic Holder and PPC 1000 hypercardioid adaptor and PB1000 Presence Booster.

Description	Code	Price (Ex VAT)
C1000S MKIV	469-230	£107.50
C1000S MKIV + 5m XLR Lead	469-231	£108.32

AKG C1000S MKIV Pack

The pack contains an **AKG C1000S MKIV** mic, a **Studiospares Mic Stand**, a 5m **Neutrik XLR Lead** and a **Studiospares Steel Mesh Popkiller**.

Description	Code	Price (Ex VAT)
C1000S MKIV Pack	469-235	£124.99



NEW
LOWER
PRICE

WHY

buy a condenser microphone?

The diaphragm of a condenser or electret microphone weighs between 5 and 50 times less than a dynamic. Therefore the condenser can respond much quicker to the rapid and minute changes in air pressure of complex sound waves.

A condenser microphone will practically always produce a more accurate sound than a dynamic.

If you need more information, please contact our technical sales team, who will be glad to help further.

AKG C451B Cardioid

Condenser Microphone

An excellent tool for accurately capturing signals rich in transients such as drums, instruments with a percussive sound, acoustic guitar, or for overhead miking.

- Identical acoustics to legendary CK 1
- Precise, nearly frequency independent cardioid
- Extremely accurate signal transfer
- Ruler-flat on-axis frequency response
- Frequency response 20Hz - 20kHz



Description	Code	Price (Ex VAT)
C451B	419-790	£240.83
C451B Matched Pair	419-792	£582.50

Schoeps V4 U

Condenser Microphone

Unites the outstanding technical characteristics typical of Schoeps with a timeless, classic design.

- Small-diaphragm capsule architecture, with bevelled collar for controlling the polar response
- Warm, clear sonic character with smoothly rolled-off diffuse-field response
- Diffuse-field response parallel to the omni response, with a gentle roll-off at high frequencies
- Very high maximum SPL



NEW

Description	Code	Price (Ex VAT)
V4 U	711-690	£1702.00

Sennheiser MK4

Condenser Microphone

The MK 4 is a large-diaphragm true condenser microphone for professional studio recordings.

- Large-diaphragm capsule (1")
- True condenser design
- 24-carat gold-plated diaphragm
- Full metal housing
- Capsule shock-mounted internally to minimise structureborne noise
- Designed for project studios and stage use
- Low inherent self-noise and high maximum SPL
- Includes mic clamp and pouch



Description	Code	Price (Ex VAT)
MK4	455-200	£207.50

PRICE

changes

This catalogue was priced on 1st December 2014.

Current prices may be higher...

see our website for up to date prices.

PDF

catalogue

Want this catalogue on your phone or laptop?

The Studiospares catalogue is now available in PDF format.

visit www.studiospares.com/page/pdfcatalogue!

MXL 990

Large Diaphragm Condenser Microphone

The MXL 990 is the big brother of the MXL 770, a large-diaphragm condenser mic with a FET preamp provides silky sweet high end and retains tight, solid low and midrange reproduction.

- Vintage body style with champagne finish
- FET preamp with balanced output
- Professional sound quality in both digital and analog recordings
- Includes custom shockmount, mic stand adapter and carrying case
- Cardioid response. Phantom powered



Description	Code	Price (Ex VAT)
990	315-000	£65.83
990 Stereo Version	315-170	£124.99
990/991 Recording Kit	315-010	£82.50

MXL 2010

Condenser Microphone

Sweet, silky and transparent. Perfectly at home on vocals and instruments makes the 2010 so versatile. Omni, cardioid, and Figure-8 polar patterns

- All-purpose microphone with a warm, transparent sound
- Class A amplification for a vintage tone with a clear top end
- -10 dB attenuation switch for high sound pressure levels
- Inc elastic suspension and foam windshield
- Phantom powered



Description	Code	Price (Ex VAT)
2010	315-090	£162.50

MXL 440

Studio Condenser Microphone

This multipurpose large diaphragm studio condenser microphone is perfect for most variety of studio applications.

- Pressure gradient condenser mic
- Cardioid polar pattern
- Maximum SPL for 0.5% THD 130dB
- Frequency response 30Hz – 20kHz
- MXL 440 Vocal Recording Kit includes: MXL 440 Condenser Microphone, MXL Shockmount, Pop Shield & 10ft Cable



Description	Code	Price (Ex VAT)
440	315-020	£49.92
440 Vocal Recording Kit	315-025	£65.83

Neumann U87 Ai

Cardioid + Omni + Fig. 8

Still the most prestigious and respected mic in any studio.

Warm sound through large capsule giving smooth and extended bass response. Suited to any application where quality is of paramount importance. This updated version has an elevated capsule voltage to provide greater sensitivity and even less self noise. An industry standard for lead vocalists. 10dB pre-attenuator. Switched bass cut at 30Hz and 200Hz.

The Studio set includes a U87 large diaphragm microphone, a EA87 shockmount and wooden box. The Stereo set includes 2x U87 large diaphragm microphones, 2x EA87 shockmounts and an aluminium case.

Description	Code	Price (Ex VAT)
U87 Ai Nickel	416-040	£1714.66
U87 Ai Black	416-041	£1714.66
U87 Studio Set - Nickel	416-080	£1832.50
U87 Studio Set - Black	416-085	£1832.50
U87 Stereo Set - Nickel	416-090	£3499.17
U87 Stereo Set - Black	416-095	£3499.17

Accessories

Description	Code	Price (Ex VAT)
EA87 Elastic Suspension Black	416-180	£199.17
EA87 Elastic Suspension Silver	416-185	£199.17



Neumann U89i

Condenser Microphone

A newly developed and smaller microphone from the popular classic U87 which comes with 5 directional characteristics, 2-level low-cut filter and switchable pre-attenuation providing maximum flexibility.

- Higher max SPL level up to 134dB and can be increased to 140dB
- Added rotary switch activates a filter below 80Hz or 160 Hz frequencies
- Very even diffuse-field response for all polar patterns



Description	Code	Price (Ex VAT)
U89i Black	416-050	£1624.16
U89i Nickel	416-055	£1624.16

Neumann TLM49 Cardioid

Condenser Microphone

Studio microphone with retro look and warm sound.

- Sound profile optimised for vocal performance
- Pressure gradient transducer with the large-diaphragm capsule
- Transformerless output circuitry
- Open wire mesh headgrille
- Complete set with elastic suspension



Description	Code	Price (Ex VAT)
TLM49	416-420	£999.17

Neumann TLM103 Cardioid

Condenser Microphone

The mic for everyone who, despite budget limitations, does not want to do without the uncompromising Neumann sound.

- Large diaphragm cardioid microphone
- Pressure gradient transducer with one-diaphragm capsule
- Transformerless circuitry
- Extremely low noise: 7 dB-A
- Includes swivel mount
- Straightforward handling for homerecording and professional studios
- Studio Set includes the mic boxed with an EA1 elastic suspension



Description	Code	Price (Ex VAT)
TLM103 Nickel	416-400	£607.50
TLM103 Black	416-410	£607.50
TLM103 Studio Set Nickel	416-460	£690.83
TLM103 Studio Set Black	416-465	£690.83
EA103 Elastic Suspension only	416-010	£174.00

Neumann TLM102 Cardioid

Condenser Microphone

A high-quality large-diaphragm cardioid condenser microphone.

- Large-diaphragm microphone with cardioid directional characteristic built with transformerless circuitry
- High maximum sound pressure level
- Slight presence boost above 6 kHz
- Frequency range: 20 Hz - 20 kHz with a presence boost above 6 kHz



Description	Code	Price (Ex VAT)
TLM102 Black	416-430	£390.83
TLM102 Nickel	416-435	£390.83

FREE catalogue
Are you reading someone else's catalogue? Why not call us and order your own copy...
it's free!

MORE PRODUCTS online

DELIVERY BEFORE NOON no problem

MICROPHONES

Studio Condenser Microphones

CONTINUED

Studiospares S1200 Cardioid · Omni · Hypercardioid

3-Capsule Condenser Microphone

Based on small 19mm diameter gold sputtered capsules.

- Supplied with 3 capsules: Cardioid, HyperCardioid and Omni-Directional
- Frequency response Cardioid 22Hz - 19kHz
- Frequency response Hyper Cardioid 24Hz - 18kHz
- Frequency response Omni 20Hz - 21kHz
- Two Bass Roll Off Filters @ 75Hz and 150Hz
- Two Attenuation levels -10dB and -15dB
- Includes a microphone clip and a foam windshield
- With each capsule being dedicated to a specific polar pattern, the off axis response is held within tight limits



Studiospares S1000

Condenser Microphone

Essentially the same as the S1200 but with a cardioid capsule.

Description	Code	Price (Ex VAT)
S1200	449-920	£52.00
S1000	448-500	£49.17

MXL V67GS

Vocal Condenser Microphone

Class-A FET circuitry and a transformer coupled output for an open and pure sound. It offers a smooth rising presence peak which is preferred for vocals when there is a heavy low end in the mix. Cardioid response

- Bass roll-off and attenuator for any recording situation. 6dB/octave @150Hz
- Max SPL 130dB. Equivalent noise 20 dB (A-weighted IEC 268-4)
- Cardioid pickup pattern
- Stand mount included



MXL V67i

Dual Diaphragm Condenser Microphone

This model is the large, dual diaphragm version designed with two selectable diaphragms for Warm or Bright sound.

- Front side warm, opulent sound & back side brighter more airy tube mic sound
- Bass roll-off and attenuator for any recording situation. 6dB/octave @150Hz
- Pressure gradient condenser mic
- Response 30Hz - 20kHz
- Equivalent noise 20 dB (A-weighted IEC 268-4)
- Stand mount included



Description	Code	Price (Ex VAT)
V67GS	315-060	£108.00
V67i	315-070	£149.17

Studiospares S1105

Condenser Microphone - Cardioid · Omni

Easily the best large capsule microphone around!

Much of this microphone's technology is unseen. For example, the conventional protective mesh is not steel but copper which is more expensive but provides the best screening material against both magnetic and RF interference.

The capsule preamplifier is amongst the quietest available being based on FETs which also present an ideal high impedance which would otherwise change the S1105's tonal characteristics. The output is transformer driven to provide a very high common mode rejection figure to allow long microphone cable runs without the possibility of the cable picking up RF or magnetic interference.

The capsule has been artificially aged to provide long term stability in the years to come. The response is really smooth and is still going strong down at 20Hz. The upper end is flat to 12kHz where the response is allowed to slightly rise providing 'a presence lift' to cut through the mix. The polar response confirms this microphone's cardioid off axis response as being amongst the best. The Omni pickup pattern produces a beautifully round sound full of warmth. Bass roll off switch reduces the response by 6dB at 100Hz to avoid low frequency rumbles. Weight 0.5kg.

Complete with carry case, and an elastic suspension.

Specification:

1" diameter dual Gold sputtered capsule,

Pickup pattern Cardioid and Omni,

Maximum SPL @1kHz 125dB @ 0.5% distortion

Equivalent Noise $\leq 20\text{dB}$ (A weighted)

Sensitivity $-41\text{dB} \pm 2\text{dB}$

Frequency range 20Hz - 20kHz

Signal/noise ratio 76dB

Powering 48Vphantom power



Studiospares S1005

Cardioid Only Version

Retains all the features of the S1105 but without the omni directional characteristic. When quality is taken into account, no other microphone represents such incredible value. Accessories: Elastic suspension and carrying case.

Description	Code	Price (Ex VAT)
S1105	449-570	£57.50
S1005	449-560	£49.90
Foam Windshield	448-590	£9.80
Spare Rubber Band	711-573	£1.95

Studiospares S1105/S1005 Packs

Pack 1 Contains

- Studiospares S1105 or S1005 microphone
- Studiospares Mic Stand,
- 5m XLR Lead
- Studiospares Stonewall Dual Blast Filter

Pack 2 Contains

- Studiospares S1105 or S1005 microphone
- Studiospares Mic Stand (without boom),
- 5m XLR Lead
- Studiospares RED 50 Microphone Sound Filter



S1105/S1005 Pack 1

Description	Code	Price (Ex VAT)
S1105 Pack 1	449-571	£75.00
S1105 Pack 2	449-572	£97.50
S1005 Pack 1	449-561	£67.50
S1005 Pack 2	449-562	£89.90

STUDIOSPARES

DELIVERY BEFORE NOON
no problem

SATURDAY DELIVERY
no problem

DELIVERY BEFORE 10AM
no problem

AKG P120

Condenser Microphone

Offers solidly built quality, outstanding performance and excellent value

- 2/3-inch low-mass diaphragm delivers a clear sound
- Switchable bass-cut filter eliminates rumble or footfall noise
- Switchable 20dB attenuation pad for SPLs up to 150 dB
- Audio Frequency bandwidth 20 to 20000 Hz
- Sensitivity 24 mV/Pa
- Equivalent Noise Level 19 dB-A
- Signal to Noise 75 dB-A



NEW

AKG P220

Condenser Microphone

Offers a warm and clear sound for lead vocals, acoustic guitar and brass instruments.

- Rugged all-metal body and robust design withstands tough day-to-day use
- Switchable bass-cut filter eliminates rumble or footfall noise
- Switchable attenuation pad for high SPL applications up to 155 dB SPL
- Audio Frequency bandwidth 20 to 20000 Hz
- Sensitivity 20 mV/Pa
- Equivalent Noise Level 16 dB-A
- Signal to Noise 78 dB-A
- Preattenuation Pad -20 dB
- Bass Cut Filter 300 Hz - 12 dB/octave
- With a spider-type shock mount in an aluminum carrying case



NEW

AKG P420

Condenser Microphone

An ideal tool for stereo miking techniques and ambient recording.

- One-inch dual-diaphragm multi-pattern true condenser microphone
- Low noise electronics and transformerless output for high dynamic range
- Switchable attenuation pad for SPLs up to 155 dB
- Audio Frequency bandwidth 20Hz - 20kHz
- Sensitivity 28 mV/Pa
- Equivalent Noise Level 15 dB-A
- Signal to Noise 79 dB-A
- Pre attenuation Pad -20 dB
- Bass Cut Filter 300 - 12 dB/octave
- With a spider Shock Mount and Aluminium Carrying Case



NEW

Samson MTR201A

Studio Condenser Microphone + Accessories

Ideal for use as a room microphone or for close miking a variety of instruments both live and in the studio.

- Featuring a wide dynamic range and the ability to handle high SPLs
- Cardioid pickup pattern
- 1" Gold sputtered diaphragm condenser capsule for lower distortions
- Designed to handle SPLs up to 132dB
- The -10dB attenuation switch increases the maximum acceptable sound level
- Cardioid pickup pattern increases isolation
- 20Hz-20kHz frequency response
- Complete with an elastic suspension, pop filter and carry case



Samson MTR231A

Studio Condenser Microphone + Accessories

Essentially the same specifications as the MTR 201A but includes three switchable pickup patterns, cardioid, omni directional and Bi-directional (fig of 8) Includes a pop filter, shockmount and carry case.

Description	Code	Price (Ex VAT)
MTR201A	388-960	£107.50
MTR231A	388-970	£149.99

Brauner Phantom

Cardioid Condenser Microphone

Both models share specifications. Any differences are listed.

- Frequency Range - 20 Hz - 22 kHz
- Maximum SPL -142 dB SPL @ 0.3 % THD
- Signal to Noise > 83 dB (1 Pa/1 kHz)
- Phantom powered 48-52v
- Includes mic cradle

Brauner Phantom Classic

Cardioid

Embodies reduction to the absolutely essential without compromise in performance.

- Distinguished by a natural and pristine sound character
- Cardioid Response
- FET Front end for lowest noise platform
- Nominated for TecAward in 2003



Brauner Phantom V

Omni/Cardioid/fig 8

If you are looking for a unique microphone with its own unique character, look no further than the Phantom V.

- Omni, Cardioid and Fig 8 polar patterns
- Attenuator reduces the output level by 10 dB
- FET Front end for lowest noise platform



Description	Code	Price (Ex VAT)
Phantom Classic	499-020	£729.00
Phantom V	499-030	£1648.33

Lewitt LCT140

Condenser Microphone

Perfectly suited for quality-conscious casual users.

- 2/3-inch back-electret condenser microphone
- Cardioid pickup pattern suppresses off-axis sound
- Wide dynamic range of 124 dB
- Transformerless output immune to electromagnetic interference
- LED display can optionally be switched on and off
- 3 position switchable pre-attenuation pad 0, 10, 20dB
- Hexagonal ruthenium-galvanized steel mesh grille to prevent wear and abuse
- Includes shock mount, windshield and artificial leather bag



NEW

Lewitt LCT240

Condenser Microphone

Equipped with a high-performance 17mm diameter back-electret capsule delivering a warm, distortion-free and natural sound.

- Transformerless circuitry which makes it immune to interference
- Attenuation and clipping history and automatic attenuation
- Illuminated user interface for handling in the dark
- Cardioid polar pattern for effective isolation
- Frequency Range 20Hz - 20kHz
- Dynamic range of 130 dB
- Attenuation pad 0 dB, 10 dB, and 20 dB
- Max SPL 166dB with 20dB attenuator switched in
- Includes shock mount, windshield and artificial leather bag



NEW

Lewitt LCT340

Condenser Microphone

Excels at capturing acoustic and percussion instruments, drums and vocals.

- 4way pre-attenuation pad 0 dB, 6 dB, 12 dB and 18 dB
- Illuminated user interface with dual coloured LEDs
- Frequency range 20Hz - 20kHz
- Signal/Noise ratio 79dB-A
- Max SPL 157dB
- Transformerless circuitry which makes it immune to interference
- Ultra thin externally biased, gold-layered low mass diaphragm
- Dynamic range 124 dB. Self-noise level 15 dB
- Includes shock mount, windshield, Lb leather bag



NEW

Lewitt LCT550

Condenser Microphone

The first and only large-diaphragm studio microphone ever to achieve 0 dB-A self-noise.

- Dynamic range of 140 dB-A
- Three pre-attenuation levels 0 dB - 6 dB and -12 dB maximum SPL 143 dB-A
- Two high-pass filters: 80Hz, 12dB/octave and 160Hz, 6dB/octave
- 0dB-A electronics only, 3 dB-A according to IEC 60268-1 due to Brownian motion
- Cardioid polar pattern
- Includes shock mount, windshield and Lb artificial leather bag



NEW

Description	Code	Price (Ex VAT)
P120	469-440	£74.17
P220	469-460	£115.83
P420	469-470	£149.17

Sontronics STC-2

Condenser Microphone

A large-diaphragm cardioid condenser mic which employs a one-inch, gold sputtered capsule ideally suitable for recording vocals, spoken word and acoustic instruments.

- Available in silver or black finish
- Very smooth high-frequency roll-off
- Spider suspension mount provided
- Manufacturers Lifetime warranty
- In an aluminium flightcase with elastic suspension shockmount



Description	Code	Price (Ex VAT)
STC-2 Black	325-270	£132.50
STC-2 Silver	325-271	£132.50

1000s
of products
Available from stock!

Description	Code	Price (Ex VAT)
LCT140	456-120	£162.50
LCT240	456-050	£186.67
LCT340	456-060	£337.50
LCT550	456-140	£540.83

MICROPHONES

Studio Condenser Microphones

CONTINUED

Behringer B5

Condenser Microphone

A fantastic all-purpose condenser microphone.

- 2 interchangeable capsules with cardioid and omnidirectional pickup patterns
- Low-mass gold-sputtered diaphragm
- Low-noise transformerless FET input
- Smooth, super-wide frequency response and incredible musicality
- Switchable low-frequency roll-off and -10 dB input attenuation
- Custom microphone stand adapter, windscreen and transport case included



NEW LOWER PRICE

Description	Code	Price (Ex VAT)
B5	381-140	£49.17

Behringer B1 Cardioid

Condenser Microphone

Gold-sputtered, large-diaphragm studio condenser microphone.

- Ideal as main and support microphone for studio and live applications
- Cardioid pickup pattern
- Pressure-gradient transducer
- Switchable low-frequency roll-off and -10 dB input attenuation
- Low-noise transformerless FET input
- Suspension mount, windscreen and aluminum transport case included



NEW LOWER PRICE

Description	Code	Price (Ex VAT)
B1	381-110	£57.30

Ear Trumpet Labs Edna

Condenser Microphones

Retro-industrial side-address small diaphragm condenser microphone.

- Effective for live or studio use for acoustic instruments or vocals
- Small (12mm) diaphragm condenser capsule
- Cardioid pickup pattern
- Integral silk and mesh pop filter
- Transformerless FET fully balanced electronics
- Metal tool case with foam padding



NEW

Ear Trumpet Labs Edwina

Condenser Microphones

Large-diaphragm (26mm) condenser microphone in a bold industrial pivoting mount for maximum flexibility.

- Tuned for live vocals in demanding stage settings
- Smooth sound excels at all kinds of studio duties
- Cardioid pickup pattern
- Side or end address, using pivot
- Internal shock dampers and internal silk and mesh pop filter
- Metal tool case with foam padding
- Transformerless FET fully balanced electronics



NEW

Description	Code	Price (Ex VAT)
Edna	456-460	£310.00
Edwina	456-410	£340.00

MICROPHONES

Valve Microphones

MXL V69 MEDT

Valve Condenser Microphone

The Mogami Edition Tube microphone is said to be the "standard for excellence for tube mics" continuing to impress musicians and artists with its rich midrange, punchy forward character and mix-ready vocals.

- 12AT7 dual triode valve
- Transformerless design.
- Produces a resounding vintage tone
- Ideal mic for hip-hop and hard rock
- Accessories. Carry case, power supply, elastic suspension. Mogami mic cable



Description	Code	Price (Ex VAT)
V69 MEDT	315-100	£249.17

AKG P820

Tube Microphone

incorporates two capsules mounted back to back.

- Nine different polar patterns.
- ECC83 double triode tube with it's inherently high impedance input
- Creates that natural warm sound only possible with a tube amplifier
- Frequency response 20Hz - 20kHz
- Sensitivity 20mV/Pa.
- Equivalent Noise Level 16dB-A.. * Signal/Noise 78dB-A
- Pre Attenuation Pad -20dB
- Bass Cut Filter 80Hz/12dB octave. Selected on remote unit
- Maximum SPL 155dB



NEW

Description	Code	Price (Ex VAT)
P820	469-480	£457.50

AKG C12VR

Tube Condenser Microphone

The C12VR is an exact replica of the original C12, from the capsule sound to the original 6072A vacuum tube. The only difference is that it's self noise and some components are optimised to meet the current state of the art.

- Nine remotely selectable polar patterns
- 10 - 20 dB attenuator. Max SPL 148dB
- Includes an aluminum carrying case, power supply, cable, windscreen, and spider type shock mount



Description	Code	Price (Ex VAT)
C12VR	469-120	£3149.00

PRICE changes

This catalogue was priced on 1st December 2014.

Current prices may be higher...

see our website for up to date prices.

Telefunken U48

Classic Tube Condenser Microphone

The bi-directional capability is useful in more 'ambient' recording environments where the engineer recording the sound does not want hear as much of the room ambience as with an omnidirectional or cardioid pick-up pattern.

- Polar Pattern Cardioid and Figure 8
- SPL 138 dB. Response 20Hz/20kHz
- Equivalent Noise 24 dB
- Includes. Locking Case, NG Style Power Supply, Shock Mount, Wooden Box



Description	Code	Price (Ex VAT)
U48	499-350	£5590.00

Mojave MA-100

Condenser Microphone

Featuring capsules with 3 micron gold sputtered diaphragms.

- Military grade JAN5840 pentode vacuum tube wired as a triode
- Vacuum Tube operates as a unity gain cathode follower.
- The small 20.5mm capsule has an excellent transient response
- Jensen output transformer for best common mode rejection
- Frequency response 20Hz - 20kHz +/- 3db
- Maximum SPL 130dB.
- Sensitivity -37dB ref 1V/pa
- Supplied with power supply, shock mount and cables
- Great for percussion, acoustic instruments, pianos, choral recordings, Stereo pairs



NEW

Mojave MA-200

Condenser Microphone

An upmarket design by David Royer supplied with a cardioid capsule.

- Military grade JAN5840 pentode vacuum tube wired as a triode
- Vacuum Tube operates as a unity gain cathode follower
- The large 25mm capsule provides warmth and a natural sound
- Jensen output transformer for best common mode rejection
- Frequency response 20Hz - 20kHz +/- 3db
- Maximum SPL 120dB.
- Supplied with power supply, shock mount and cables
- Great for acoustic instruments, vocals and orchestral recordings



NEW

Mojave MA-300

Condenser Microphone

Supplied with two back to back capsules.

- Tube Condenser Microphone with 9 Polar Patterns
- Featuring two 25mm diameter capsules with 3 micron thick gold sputtered diaphragms
- Military grade JAN5840 pentode vacuum tube wired as a triode
- The large 25mm capsule provides warmth and a natural sound
- Frequency response 20Hz - 20kHz + 3db
- Bass Cut operates at 6dB/octave below 100Hz
- Maximum SPL 120dB with attenuation Off, 135dB pad On



NEW

Description	Code	Price (Ex VAT)
MA-100	456-500	£530.00
MA-200	456-520	£730.00
MA-300	456-530	£860.00

MICROPHONES

USB Microphones

Samson UB1

USB Boundary Microphone Omni



The Samson UB1 is a miniature, low-profile surface mount condenser microphone featuring an omni directional pick-up pattern and USB output. Since the UB1 is a class compliant USB device, it is plug and play compatible with Macs and PC's. It ships with Cakewalk's Sonar LE, and comes with a 2m USB cable and a durable storage case. The mic is ideal for placing on a conference table, podium, or altar and can also be mounted using its keyhole mounting points. Recording at 16-bit, 44.1kHz - 48 kHz, it has a solid zinc body, Black finish and sturdy steel grille.

Description	Code	Price (Ex VAT)
UB1	388-480	£58.32

Samson C01U Cardioid

USB Studio Microphone

Bridges the gap between mid-level USB audio adapters and pro-line products.

- 16-Bit resolution, 44.1-48kHz sampling
- Cardioid pickup pattern
- Large 19mm diaphragm
- Smooth, flat frequency response
- Includes desktop mic stand, mic clip, USB cable, carry pouch and Cakewalk Recording Software for your PC



Samson C01U Pro Cardioid

USB Studio Condenser Microphone

Updated version of the C01U, now with a headphone output for zero-latency monitoring and an improved signal-to-noise ratio.

Samson C03U Cardioid

USB Studio Microphone

Delivers pristine audio quality with enhanced capabilities, most notably multiple pickup patterns.

- 16-Bit resolution, 44.1-48kHz sampling
- Switchable cardioid, omni, and figure-8 pickup patterns
- Switchable high-pass filter
- High SPL neodymium element
- Smooth, flat frequency response
- Includes desktop mic stand, mic clip, USB cable and carry pouch



Description	Code	Price (Ex VAT)
C01U	388-160	£54.99
C01U Pro	308-010	£54.99
C03U	388-150	£79.16

Studiospares UX500
USB Condenser Microphone

The UX500 bridges the traditional studio microphone to digital technology by providing an outstanding studio microphone with a digital USB output.

25mm Electret condenser capsule provides a high output to reduce system noise. Bass roll off filter at 150Hz to attenuate sub sonic frequencies. Attenuation Pad - 10dB increases maximum SPL. Frequency response 20Hz - 20kHz. Sensitivity - 35dB + 2dB. Noise < 22dB weighted. Maximum SPL 130dB. MAC and PC compatible. Cutting edge A-D converters. Powering via USB connection. This product equals and beats products costing treble.

Includes a Elastic Shockmount and USB lead.

Description	Code	Price (Ex VAT)
UX500	449-960	£40.83



sE X1 USB

Large Diaphragm USB Condenser Microphone

A professional studio microphone for use anywhere!

- Type: Condenser
- Directional pattern: Cardioid
- Frequency range: 20Hz - 20kHz
- Sensitivity: -27dBV (mV/Pa)
- Equivalent noise level: 19.8 dB
- Dynamic Range: 135dB
- Connection: USB 2.0
- Matte Black finish
- Compatible with the sE Isolation Pack
- Includes a mic clip as standard



Description	Code	Price (Ex VAT)
X1 USB	422-450	£165.83

Audio Technica AT2020USB

USB Condenser Microphone

Perfect for home studio recording, field recording, podcasting, and voiceover use.

- Side-address studio condenser
- USB digital output (Windows and Mac compatible)
- Custom-engineered low-mass diaphragm
- Cardioid polar pattern
- Low self-noise
- Includes tripod desk stand, pivoting stand mount, cable and storage pouch



Description	Code	Price (Ex VAT)
AT2020USB	447-080	£111.67

Studiospares UX100
USB Dynamic Microphone

A dynamic handheld microphone that features an XLR, headphone and a USB I/O.

The UX100 can plug directly into any sound console or any USB input. The microphone's on/off switch lets you control the audio into the XLR output, allowing you to perform in live settings and record to a computer simultaneously. This microphone also features a built in 3.5mm stereo headphone jack with a volume control for low latency monitoring during recording. Built with a cardioid pickup pattern and a high quality A/D converter, the UX100 has a 16-bit 44.1/48kHz sampling rate ensuring the sound reproduction in both live and recording applications is clear, detailed and accurate. It is also compatible with any computer based digital workstation. Supplied with USB cable, microphone holder and mini desk stand.

Description	Code	Price (Ex VAT)
UX100	449-270	£29.50
UX100 + Mic Stand	449-275	£36.50



Samson G-TRACK

USB Mic System

USB Condenser Mic with Audio Interface.

- Large diaphragm (19mm) studio condenser USB microphone
- Works seamlessly with GargeBand, Logic Express and Logic Pro
- Record electric guitars and vocals at once and stereo instruments like keyboards or drum machines
- Heavy-duty desktop stand, Audio I/O and USB cables included



Description	Code	Price (Ex VAT)
G-Track	388-230	£74.17

VISIT
our trade counter

You'll get friendly advice and immediate access to 8000+ product lines!

MORE PRODUCTS
online

ALL PRICES EXCLUSIVE OF VAT.

DELIVERY BEFORE NOON
no problem

MICROPHONES

USB Microphones

CONTINUED

Behringer C1U

USB Condenser Microphone

Affordable studio USB microphone...

The Behringer C-1U features a USB output for plug-and-play style recording with a laptop or desktop computer. Record using your favourite software without any interfaces or preamplifiers. The C-1U is well suited for capturing vocals and instruments in today's digital recording environments.

The low-noise condenser microphone features a cardioid pick-up pattern. The pattern reduces ambient room noise and feedback. The C-1U is an affordable and ideal choice for vocals, piano, guitar, amp-cabinets and more.

Description	Code	Price (Ex VAT)
C1U	382-130	£33.30



NEW
LOWER
PRICE

Studiospares SB450USB

USB Boundary Microphone

A highly sensitive USB Boundary Electret Microphone with a multitude of applications.

- USB output for Mac/PC
- Highly sensitive back Electret capsule captures sounds from all directions
- Subsonic filter to remove troublesome frequencies that exist close to walls and floors
- Probably the best boundary mic around
- Supplied with 3m of cable



Description	Code	Price (Ex VAT)
SB450USB	449-690	£24.99

Blue Snowball

Bundle USB Microphone

Captures a range of sound sources with amazing clarity and depth.

- Condenser, pressure gradient with USB digital output
- Omnidirectional or cardioid polar pattern
- Frequency response of 40Hz - 18kHz
- 44.1kHz/16 bit
- Weight: 460g
- Dimensions 325mm (circumference)



Blue Snowball Ice

USB Skype Microphone

The custom condenser capsule with cardioid pattern offers crystal clear audio for communicating, creating and recording.

- Pressure gradient condenser capsule
- 44.1kHz 16 bit A/D conversion
- Plug n play on PCs and Macs
- Includes an adjustable desktop microphone stand and USB cable



Description	Code	Price (Ex VAT)
Snowball	424-530	£56.00
Snowball Ice	424-670	£46.00

DELIVERY BEFORE 10AM
no problem

Rode NT-USB

USB Condenser Microphone

Fully compatible with all mainstream recording applications on both Windows and Mac OS.

- Cardioid polar pattern
- JFET impedance converter with bipolar output buffer
- A/D converter 16bit 48kHz
- Frequency Range 20Hz-20kHz
- 110dB SPL (@ 1kHz, 1% THD into 1kΩ load)
- Pop filter clips on to lower part of the body; 3/8" stand mount thread



Description	Code	Price (Ex VAT)
NT-USB	497-310	£107.50

Studiospares XLR-USB Mic Preamp

USB Microphone Preamp

Simply adapts any condenser or dynamic microphone for USB inputs.

- Interfaces with Windows and Mac OS X
- No driver software necessary
- Adjustable mic gain control
- Adjustable headphone output
- 48V phantom power AND Phantom off switch
- 16-bit A/D converter
- 44.1kHz/48kHz sampling rate



Description	Code	Price (Ex VAT)
XLR-USB Mic Preamp	449-470	£28.30

Centrance Micport Pro

USB Microphone Preamplifier

MicPort Pro is a portable, low noise USB mic preamp featuring 24-bit/96kHz performance.

- Lowest-noise mic preamp with 24-bit/96kHz A/D converter
- 103.5dB dynamic range
- 48V phantom power
- Loud headphone amp for zero latency monitoring with stereo capability
- Studio-grade control knobs for preamp gain and headphone volume



Description	Code	Price (Ex VAT)
MicPort	219-630	£116.00

MICROPHONES

Ribbon Microphones

sE X1R

Ribbon Microphone

A classic sounding ribbon mic with a gentle HF lift

- For anything acoustic like jazz, classical, string parts, drum overheads or folk
- Hugely powerful Neodymium magnets raise the output level
- Aluminium ribbon element
- Frequency Response 20Hz - 16kHz + 1dB
- Sensitivity -55dB ref 1V/Pa + 1dB
- Directional pattern Fig of 8
- Max SPL 135dB



Description	Code	Price (Ex VAT)
X1R	422-470	£119.00

Royer R-101

Ribbon Microphone

The R-101 microphone utilises the patented offset-ribbon transducer design for a very smooth frequency response and imparting a warm analogue feel to digital recordings.

- High SPL capabilities for electric guitar and percussion
- No internal electronics to overload or distort. Max SPL 135dB @ 30Hz
- Figure 8 polar response.



Royer R-121

Ribbon Microphone

Royer's award-winning flagship microphone gives you all of the warmth and natural sound that experienced engineers have long turned to ribbon mics for.

- Absence of high frequency phase distortion
- High SPL capabilities of 135dB
- Patented Offset Ribbon Technology



Description	Code	Price (Ex VAT)
R-101	408-810	£569.00
R-101MP Matched Pair	408-812	£1100.00
R-121	408-820	£875.00
R-121MP Matched Pair	408-822	£1745.83

Royer R122

Ribbon Microphone

A new breed of modern ribbon microphone designed for today's studio and live environments.

- Patented offset-ribbon technology
- 2.5-micron aluminium ribbon
- Flux-frame & rare earth Neodymium magnets
- Multi-layered wind screen provides superior protection to ribbon element
- Maximum SPL 135 dB @ 30 Hz
- Freq response 30 - 15,000 Hz ± 3dB
- Polar Pattern Figure of 8
- Similar to the R121 but with 14dB more output with FET front end
- Phantom powering



Description	Code	Price (Ex VAT)
R122 Active	408-840	£1250.00
R122MP Active Matched Pair	408-842	£2673.00

Studiospares S300

Ribbon Microphone

Delivers a warm and natural classic sound. The rich low end response is balanced by the transparent mid/high frequency output

- Pre Aged aluminium ribbon for stability
- Ribbon assembly user replaceable with out having to re calibrate
- Very low noise front end FETs coupled with an impedance matching trans-former toboost the output
- Max SPL150dB @ 1kHz
- Frequency response 20Hz - 18kHz
- Signal/Noise ratio 69dB @ 1 Pa
- Includes a bag, foam windscreen and elasticated mic holder.
- Compares favourably with products costing treble



MXL R144

Small Ribbon Microphone

The MXL R144 is a classic looking ribbon mic offering warmth and smoothness on a budget.

- Figure-8 polar pattern
- Mellow sound with a rich midrange and rolled-off top end
- 130dB SPL capability—ideal for horns and electric guitars
- 1.8-micron aluminum ribbon
- Perfect for a musician who needs a workhorse ribbon mic



Description	Code	Price (Ex VAT)
R144	315-050	£107.50

MicW i436

Omni iPhone/iPad mic

A professional grade microphone which plugs directly into your iPad, iPhone or iPod touch.

- High quality omni-directional vocal and instrument microphone for iOS devices
- Sensitivity and frequency response of each microphone are individually calibrated at the factory before shipping
- Kit includes Foam Windshield, Lavalier Clip, 2m Extension cable, Y adaptor for mic and headphone jacks, Carry Case



Description	Code	Price (Ex VAT)
i436	403-150	£69.99
i436 Kit	403-155	£95.83

Description	Code	Price (Ex VAT)
S300 Ribbon Microphone	449-680	£72.50
Spare Ribbon Assembly	449-689	£26.00

Coles 4030L

Studio Ribbon Microphone

Manufactured using the very latest CNC machinery and the latest magnet technology.

- Sensitivity -67dB 1V/Pa
- Ideal for the popular "Blumlein" (crossed figure-of-eight) stereo configuration
- Effective pop shield for plusive sounds
- The low frequency response is smooth and natural



Coles 4038

Studio Ribbon Microphone

The 4038 is of BBC design and used for broadcasting and recording.

- The response is flat in horizontal and vertical planes for a very natural sound
- Frequency response 30Hz-15kHz
- Extremely low non linear distortion
- Toroidal output transformer minimises the chance of interference
- Sensitivity -65dB ref 1V/Pa
- Max SPL 125dB



Coles 4104

Commentator Ribbon Microphone

Probably the world most effective commentators microphone used by the BBC, IBA, CBS and ABC.

- Cancels out a large degree of background noise
- Frequency response tailored to speech frequencies 60Hz - 12kHz
- OK with wind speeds of up to 20mph or more
- Simple attachment increases effectiveness in speeds up to 40mph
- Corrugated ribbon construction protected by a fine nylon gauze
- Body housing, brass perforated case with stainless nose and mouth screens. PVC covered handle designed to provide a natural holding position for long periods.



Description	Code	Price (Ex VAT)
4030L	499-700	£524.17
4038	499-710	£674.17
4038 Matched Pair	499-712	£1340.83
4104	499-720	£390.83

MICROPHONES
Smartphone/Tablet Microphones

Studiospares iM500
iPad/iPhone Microphone

Instant Studio/Broadcast quality recordings on your mobile, iPhone, iPod and iPad.

Perfect for field interviews, podcasting, reporting and music recording. Cardioid pickup pattern excludes unwanted sounds from the sides and rear. Cleans up sounds in a noisy environment.

Three level settings cover all levels of sound from the rasp of a trombone to recording bird songs at dawn. Headphone output for direct listening to what is being recorded without involving additional equipment. Multifunction mobile devices are a compromise between portability and performance. By using a professional microphone in a live recording situation the experience is not compromised. No adaptors necessary. Just plug in and go.

Description	Code	Price (Ex VAT)
iM500	449-490	£16.67



MXL Tempo

iPad USB Microphone

The MXL Tempo USB condenser microphone (black/red) is a lightweight mic that is compatible with the iPad allowing users to record vocals and other sounds on-the-go.

- Windows and Mac OS compatible
- High fidelity headphone jack
- iPad compatible



Description	Code	Price (Ex VAT)
Tempo Silver/Black	315-110	£57.50
Tempo Red/Black	315-115	£57.50

Studiospares iM100

Smartphone Mini Condenser Microphone

Miniature Smartphone Microphone with Cardioid Pickup Pattern to increase directionality.

- 12mm Back Electret Condenser Microphone.
- Cardioid pickup pattern rejects unwanted sounds.
- Frequency response 20Hz - 20kHz.
- Sensitivity -45dB +/- 2dB.
- Dimensions 12mm x 70mm (excluding plug)
- Enhances iPhone sound quality making it a serious recording tool.



Description	Code	Price (Ex VAT)
iM100	449-930	£12.42

Zoom IQ5

iPhone Stereo Microphone

A high-quality mid-side stereo condenser mic, perfect for recording music.

- Connects to the Lightning connector of your iPhone, iPad or iPod Touch
- Rotates for horizontal or vertical recording
- Stereo width can be set to 90° or 120°
- Zoom's Handy Recorder iOS app adjusts the width from 30° to 150°
- Black or white colour option



Description	Code	Price (Ex VAT)
IQ5 Black	377-880	£65.83
IQ5 White	377-881	£65.83

Studiospares Miniature Microphone

Smartphone Microphone

Raise the quality of your recordings using a studio quality microphone.

- Omni directional pickup pattern
- Back Electret Microphone Capsule
- Hinges for optimum pickup
- Frequency response 20Hz - 20kHz
- Does not require a battery
- Highly sensitive
- Low price reflects sourcing direct from the factory and selling direct to end user



Description	Code	Price (Ex VAT)
Miniature Microphone	449-480	£10.00

MICROPHONES

Smartphone/Tablet Microphones

CONTINUED

IK iRig Voice

iOS Android Handheld Mic

Turn your smartphone or tablet into the ultimate portable vocal studio and monster karaoke rig.

- Compact cardioid pattern minimizes feedback
- Constructed of durable, lightweight thermoplastic
- Works with dozens of karaoke, sing-along and music making apps
- Headphone jack for real-time monitoring
- Convenient on/off switch located on the mic
- Operates through the 3.5mm (1/8") TRRS analogue mic/headphone jack



NEW

Description	Code	Price (Ex VAT)
iRig Voice Blue	321-750	£22.50
iRig Voice Green	321-751	£22.50
iRig Voice Pink	321-752	£22.50
iRig Voice White	321-753	£22.50
iRig Voice Yellow	321-754	£22.50

IK iRig Mic HD

Digital Handheld iOS Microphone

Connects to an iPhone, iPad, iMac and MacBook Pro

- 24-bit audiophile-grade A/D converter, a 44.1/96 kHz
- Low noise/high definition pre-amp
- Sturdy metal-body construction
- Can also be mounted on a standard mic stand with the clip
- Lighting connector and USB cable included
- 30-pin cable available separately



NEW

IK iRig Mic Field

Digital Stereo Field Microphone

Audio-video stereo field mic for Lightning-compatible iPhone, iPad and iPod touch devices.

- Patent-pending rotatable enclosure
- 24-bit audiophile-grade A/D converter
- 44.1/48 kHz sampling rate, a 115 dB maximum SPL
- Rotates 90° for optimal audio/video positioning
- 2 high-quality cardioid electret condenser capsules
- 24-bit, 44.1 - 48 kHz A/D conversion



NEW

Description	Code	Price (Ex VAT)
iRig Mic HD	321-760	£74.99
iRig Mic Field	321-810	£74.17

Apogee Mic

Digital USB iPad Microphone

Mic by Apogee is the most compact studio quality USB microphone available for iPad®, iPhone® etc.

- Status LEDs assist best recording level
- Gain control for setting recording level
- 44.1/48kHz A/D converters
- 40dB internal preamp raises sensitivity
- Connects with multipin docking socket
- Mac OS X Mountain Lion compatible



Description	Code	Price (Ex VAT)
Mic	321-060	£137.50

Rode Smartlav

iOS Lavalier Microphone

By employing a high quality omnidirectional condenser capsule the smartLav picks up equally from all around the microphone.

- JFET active electronics
- Tiny 2.5mm condenser capsule
- Response 20Hz - 20kHz
- Connection via TRRS 4 pole mini jack



Description	Code	Price (Ex VAT)
Smartlav	417-970	£32.50

MICROPHONES

Instrument Microphones

AKG D112

Cardioid Bass Drum Microphone

Popular for miking up cabinets and stage combo amplifiers...

A purpose built microphone with a large diaphragm set in a bass cavity to extend and enhance low end sensitivity. Overload point beyond the SPL levels found in bass drums or brass instruments. Vocalists trying to emulate the 60s sounds find the D112 ideal. Smooth frequency response 20Hz-17kHz with excellent transient response. Distinctive appearance with the latest materials.

Supplied with SA40 Mic Holder.

Description	Code	Price (Ex VAT)
D112	409-060	£108.29
D112 + 5m XLR Lead	409-065	£113.32
D112 + 5m Pro XLR Lead	409-066	£114.58
D112 + 10m XLR Lead + Stand	409-067	£115.83



AKG

Audix i5 Cardioid

Instrument Microphone

A dynamic instrument microphone used for stage, studio and broadcast applications.

- Cardioid pickup pattern
- Frequency response: 50Hz - 16kHz
- Impedance: 150 ohms
- Precision cast zinc alloy body
- Switchcraft XLR connector
- Heavy duty nylon mic clip included



Description	Code	Price (Ex VAT)
i5	422-500	£66.20

Shure Performance PG81 Cardioid

Instrument M

A sensitive, flat response condenser microphone ideal for acoustic instruments.

- Cardioid polar pattern
- Lightweight, sensitive diaphragm
- Powered by AA battery or phantom power supply
- Internal shock mount for reduced handling noise
- Durable metal construction
- On/off switch for onstage control



Description	Code	Price (Ex VAT)
PG81	423-300	£93.30

Shure Performance PG57 Cardioid

Instrument Microphone

A versatile microphone for use with amplified or acoustic instruments.

- Cardioid polar pattern
- Dynamic cartridge with rugged coil
- Internal shock mount for reduced handling noise
- Durable metal construction
- On/off switch for onstage control
- Includes a 15 ft (4.57m) cable, break-resistant mic clip and storage bag



Description	Code	Price (Ex VAT)
PG57	423-290	£44.99

PDF catalogue

Want this catalogue on your phone or laptop?

The Studiospares catalogue is now available in PDF format.

visit www.studiospares.com/page/pdfcatalogue/

DELIVERY BEFORE 10AM
no problem

MXL CR21 Pair

Instrument Microphones

Suited for drum overheads, acoustic instruments, and pianos.

- A powerful option in tight situations
- Transformerless preamp for low noise and distortion
- Small-diaphragm capsule that captures extra detail
- Fast transient response for extra accuracy
- Frequency Response 30Hz - 20kHz
- Polar pattern Cardioid
- Equivalent noise 18 dB (A-weighted IEC 268-4)
- Max SPL for .5% THD 134 dB
- Power Requirements 48V phantom power (+/-4V)



Description	Code	Price (Ex VAT)
CR21 Pair	315-290	£107.50

MXL A-55 Kicker

Dynamic Drum Microphone

A killer dynamic mic for kick drums, bass cabinets, floor toms, congas or any other low-frequency instruments.

- Comes with a robust low-end sound that has plenty of punch
- Cardioid pick up pattern with a responsive and smooth lower end
- Sensitivity: -76 dB (+/-3 dB @ 1kHz)
- Max SPL 130dB



Description	Code	Price (Ex VAT)
A-55	315-240	£63.33

AKG P170

Instrument Microphone

For recording of overheads, percussions, acoustic guitars and other strings.

- Small-diaphragm cardioid mic
- 12mm true condenser transducer
- Audio Frequency bandwidth 20 to 20000 Hz
- Sensitivity 15 mV/Pa
- Equivalent Noise Level 19 dB-A
- Signal to Noise 75 dB-A
- SPL up to 155dB
- Preattenuation Pad -20 dB
- Phantom powered 44-52V



Description	Code	Price (Ex VAT)
P170	469-450	£65.83

Beyer M201 Hypercardioid

Instrument Microphone



Classic dynamic, 'workhorse' microphone for vocal or instrumental applications

- Rugged construction with high output moving coil transducer
- Small dimensions for unobtrusive positioning and includes clamp and pouch
- Frequency response of 40Hz-18kHz and hyper-cardioid polar pattern

Description	Code	Price (Ex VAT)
M201	410-121	£136.50

Studiospares S150

Cardioid Miniature Instrument Microphone

Part of the new generation of back electret microphones for very close miking.

Part of a new generation of miniature back electret microphones designed to be secured to the instrument, the ultimate in close miking. The frequency response is 50Hz - 18kHz so can capture the slightest nuance. Maximum SPL is 130dB so it is able to live comfortably in front of practically any instrument. Gooseneck length 105mm. Phantom powered 48 volts. An excellent all rounder that is capable of being mounted right at the source of the sound. Sold in huge quantities, hence the highly competitive pricing.

Description	Code	Price (Ex VAT)
S150	449-180	£33.25



Studiospares S980

Overhead Percussion Condenser Microphone

For anyone really serious about capturing percussive sounds accurately, the S980 Overhead Percussion Mic is a dream come true.

Small capsule electret microphones' forte is a ruler flat response resulting in a total lack of colouration. They are so flat that they are used as reference microphones for acoustic measurement. The SPL is a whopping 145dB. The small pressure gradient diaphragm can respond instantly to the initial attack of percussive sounds without overloading. The whole essence of this model is its ability to capture transients with no distortion. The response extends beyond the nominal 20Hz to 20kHz. Requires 48V phantom power.

Supplied with microphone clip.

Description	Code	Price (Ex VAT)
S980	449-670	£24.40



Shure SM57 LC

Cardioid Instrument Microphone

A well established industry standard for over 45 years!

Sturdy construction and good all round performance with the well known Shure mid-range presence peak to increase intelligibility and clarity under difficult conditions. Favoured by female backing groups and for miking up guitars, snare drums, kick drums and wind instruments.

The frequency response is 40Hz - 15kHz. The small physical size makes it inconspicuous for television, stage and theatre work.

Supplied with Mic Holder with 5/8" Thread. Use STA4 thread adaptor Code 401-100 for 3/8" stands.

Description	Code	Price (Ex VAT)
SM57 LC	423-031	£78.33
SM57 LC 3-Pack	423-033	£228.50

Studiospares SM57 Packs

Description	Code	Price (Ex VAT)
SM57 + Economy 5m XLR Lead	423-034	£83.32
SM57 + Economy 10m XLR Lead	423-035	£84.17
SM57 + Pro 5m XLR Lead	423-036	£86.67
SM57 + Pro 10m XLR Lead	423-037	£89.17
SM57 + Pro 5m XLR Lead + Short Boom Stand	423-038	£90.83
SM57 + Pro 10m XLR Lead + Short Boom Stand	423-039	£92.50



SATURDAY DELIVERY
no problem

MICROPHONES

Instrument Microphones

CONTINUED

StageLine DM-030

Dynamic Harmonica Microphone

Very good handling due to the short, ergonomic design.

- Microphone cartridge of cardioid characteristic with rubber suspension and low acoustic feedback.
- Metal body with steel basket and an acoustic filter to reduce popping when used close up
- Capsule is tuned to compliment the frequency range of the harmonica.
- Designed to be used close up to capture every nuance
- High SPL capability of 135dB. Response 80Hz - 15kHz
- Includes 5m connecting cable XLR - Jack



Description	Code	Price (Ex VAT)
DM-030	256-170	£24.90

Sennheiser e609/e906 Supercardioid

Instrument Microphone

Specially developed for miking guitar cabs face on and extremely close to the signal source.

- Rugged metal body
- Advanced shock-mount design
- Super-cardioid pick-up pattern
- Hum compensating coil
- e906 is the same as the e609, but with a 2 way switchable EQ



Description	Code	Price (Ex VAT)
e609	473-590	£87.50
e906	454-460	£124.17

Sennheiser MD421 Cardioid

Instrument Microphone

Copes with the most diverse recording conditions.

- Rugged professional microphone
- Five position bass roll-off switch
- Effective feedback rejection
- Clear sound reproduction
- Easy handling due to pronounced directivity
- 1 microphone clamp for 3/8" thread



Description	Code	Price (Ex VAT)
MD421	452-111	£257.50
MZA421-U5 Spare Mic Clip	452-260	£35.50

Sennheiser e904

Dynamic Percussion Microphone

The cardioid e904 provides great sound without getting in the way in even the most crowded set-ups.

- Specifically designed for drum applications
- Very short body
- Integrated stand mount and rim clip



Description	Code	Price (Ex VAT)
e904	454-440	£115.83

Studiospares S900

Studio Percussion Microphone

Selling at a fraction of the price of similar models costing treble...

Nothing, repeat nothing can ever compare with a miniature condenser microphone when it comes to capturing highly percussive sounds. The smaller and hence the lighter the diaphragm the better. Inspired by the legendary AKG 451 the S900 captures the sizzle of the cymbal and crack of the tom tom. Thankfully the sound is not chromium plated or metallic. Conventional dynamic microphones sound as if you are listening through a door in comparison.

The frequency response reveals why the sound is so smooth. It is ruler flat right through the 'difficult' 5kHz to 10kHz region where others exhibit 'presence peaks'. The response is +3dB from 50Hz to 19kHz and the maximum SPL is 148dB. The equivalent Noise Level is 18dB-A (IEC 268-4) A weighted. The low noise platform is attributed to the front end bipolar FETs.

Powered 9V-52V phantom powering.

Description	Code	Price (Ex VAT)
S900	448-630	£32.50



Studiospares S975/S970

Cardioid Percussion Pickup Microphones

The S975/S970 gets really close to the action. For any percussive application, this model is difficult to beat whatever the price.

The pre-polarised electret capsule has a tiny diaphragm so is able to capture the harmonics associated with percussion instruments. The upper frequency limit is beyond the range of audio measuring equipment. These microphones have little response from other local instruments due to the tight pickup pattern. They simply clip onto the body, bell or rim etc of any instrument. The gooseneck allows precise placement of the capsule. Living next to a snare drum or being clipped to the bell of a saxophone makes great demands on the overload factor.

The S975 is Phantom powered 49 volts with an SPL of 130dB, and the S970 is Phantom powered from 9 to 52 volts with an SPL of 136dB.

Description	Code	Price (Ex VAT)
S975	449-590	£31.50
S970	449-030	£29.90



Sennheiser e604

Cardioid Instrument Microphone

This space saving, compact drum and brass microphone is ideal for low visibility, close miking techniques.

The frequency response and pick-up pattern are optimised for drum sets and percussion instruments. The e604 also excels on brass and woodwind. An integral stand mount screws directly onto mic stands. The included clip attaches the mic directly to the rim of the drum. It is able to reproduce levels in excess of 160dB. The lightweight voice coil provides extended high frequencies and rapid transient response. The response extends from 40Hz to 18kHz. The tough reinforced glass fibre body takes the knocks and shocks and suppresses impact noise.

Supplied complete with pouch and mic clip.

Description	Code	Price (Ex VAT)
e604	452-870	£99.17



Studiospares S930

Instrument Microphone

Based on a moving coil capsule with Neodymium magnets, this model is very sensitive and provides a high output.

The maximum SPL level is 148dB so it can be placed in front of the bell of a trombone or 'hot' saxophone. The response in the 3kHz to 7kHz region is enhanced to provide greater clarity. Stringed and woodwind instruments become vibrant and brass instruments really come to life. The body is die cast zinc, not plastic which takes knocks and provides a high level of screening from unwanted interference.

Description	Code	Price (Ex VAT)
S930	448-620	£22.80

Studiospares SD101

Bass Drum Microphone

Studiospares most popular bass drum mic, also great for double basses.

The low frequency response just keeps going on and on down to subsonic frequencies. This type of response certainly livens up percussive sounds giving a real zing to very high transients. Bass drums are really brought to life. The body is die cast zinc not plastic so is able to provide effective screening against RF interference.

Description	Code	Price (Ex VAT)
SD101	448-660	£24.40

Studiospares SD106

Bass Drum Microphone

The moving coil microphone remains king for recording high levels of sound.

Good bass drum sounds are a breeze with the SD106. Overload is practically impossible with an SPL of 136dB. This ensures the initial high level transient is retained without distortion. Equally at home inside or outside the drum. Popular for recording trombones where the characteristic rasp is captured without compromise. The body is die cast zinc not plastic so is able to provide effective screening against RF interference. Should last a lifetime.

Description	Code	Price (Ex VAT)
SD106	449-610	£19.99

Studiospares SD107

Bass Drum Microphone

Very sensitive bass drum microphone, providing high outputs.

The maximum SPL level is 136dB so it can be placed inside a bass drum. The response is tailored by the dynamics of the capsule being slightly enhanced below 200Hz. Nothing added, nothing taken away. Pure bass drum sound. The body is die cast zinc, not plastic which takes knocks and provides a high level of screening from unwanted interference. A hardened steel mesh protects against knocks.

Description	Code	Price (Ex VAT)
SD107	449-600	£22.50

Studiospares S935

Cardioid Instrument Microphone

Equally at home covering woodwind or brass sections.

Great value Instrument microphone designed to capture excellent recordings on a range of sources. Excels at close mic applications. Very high output capability. Smooth frequency response of between 30Hz and 15kHz. Popular guitar microphone captures every nuance. Max SPL 136dB.

Description	Code	Price (Ex VAT)
S935	449-580	£16.58



Electro-Voice RE200

Condenser Cardioid Instrument Microphone



A small, light and rugged, instrument microphone.

- The capsule is a true, external-biased condenser element
- Capsule gold laminated and stabilised for long term accuracy
- Capsule a single piece of ceramic layered with gold
- Capsule is cradled in a shock-mount system for mechanical isolation
- Cardioid polar pattern
- Transformerless output
- Frequency response: 50-18000Hz.
- Sensitivity: 10mV/Pascal, open circuit, 1kHz.
- Max SPL 130dB
- Powering 12-52V DC phantom power required



Description	Code	Price (Ex VAT)
RE200	414-040	£275.00

Shure Beta 52A

Bass Drum Microphone

Designed specifically for kick drums and other bass instruments.

- Built-in dynamic locking stand adapter with integral XLR connector
- Hardened steel mesh grille that resists wear and abuse
- Advanced pneumatic shock mount system
- Neodymium magnet for high signal-to-noise ratio output



Description	Code	Price (Ex VAT)
Beta 52A	423-910	£124.17

MICROPHONES

Drum Microphone Kits

Samson Drum Mic Kits



Complete sets of cardioid pattern dynamic mics tuned for the specific purpose of miking up drum kits, catering for all different sizes. QSnare and QTom mics come with rim clips. All kits supplied in a road case.

8KIT Consisting of Samson's new QKick, QSnare and three QTom mics along with two of their large diaphragm CO1 condensers mics for overheads and a small diaphragm CO2H mic for hi hat miking.

7KIT Comprises the QKick, QSnare and three QTom mics along with a pair of CO2s. The kit includes shock mounts for the pencil mics, and a swivel clip for the kick mic. All mics feature Gold plated XLR connectors and cardioid polar patterns.

5KIT Inclusive of the QKick, a large diaphragm dynamic mic as well as the QSnare and 3x QTom mics. All mics feature Gold plated XLR connectors.

Description	Code	Price (Ex VAT)
8KIT	368-940	£215.83
7KIT	368-950	£190.83
5KIT	368-960	£124.17

ALL PRICES EXCLUSIVE OF VAT.

MICROPHONES

Drum Microphone Kits

CONTINUED

WHY

buy a drum microphone kit?

Drum Mic kits offer huge cost savings. They are grouped by application so all models will be appropriate to the task in hand. And best of all, you can see which microphones have been left behind.

If you need more information, please contact our technical sales team, who will be glad to help further.

Audix FP4/FP5/FP7

Drum Microphone Packs



FP5 Kit Pictured

With the introduction of serious microphone packages for professional artists and engineers, Audix has revolutionised drum and percussion miking by designing specific mics for specific instruments. Built to withstand the rigours of live stage applications, the Fusion series mics can also be successfully used in a studio recording environment.

FP4 - 1x F5 dynamic, 2x F2 dynamics, 1x F6 dynamic, 3x D Clips, 1x MC1 clip, 1x Aluminum carrying case with foam inserts.

FP5 - 1x F5 dynamic, 3x F2 dynamics, 1x F6 dynamic, 4x D Clips, 1x MC1 clip, 1x Aluminum carrying case with foam inserts.

FP7 - 1x F5 dynamic, 3x F2 dynamics, 1x F6 dynamic, 2x F9 condensers, 6x D Clips, 1x MC1 clip, 1x Aluminum carrying case with foam inserts.

Description	Code	Price (Ex VAT)
FP4	422-930	£165.83
FP5	422-940	£207.50
FP7	422-950	£299.17

AKG Rhythm Pack

Drum Microphone Kit

AKG's Rhythm Pack is a complete convenient set of microphones for miking up a drum kit in any live situation.

- 1x D 112
- 2x C 430 for overheads
- 3x D 40 for toms and snare
- Protective aluminium carrying case



Description	Code	Price (Ex VAT)
Rhythm Pack	439-890	£390.00

1000s
of products
Available from stock!

Studiospares SD700/SD800

Drum Microphone Kits

No other kits provide such astonishing performance, even for double the money.

Two kits each housed in a carrying case. Individual microphones are easily the finest in their field and are chosen for their ability to capture high SPLs yet retain the nuances of the differing percussive sounds.

SD700

Contains

- 1x **SD101** Bass Drum Microphone
- 4x **S930** Instrument Microphones
- 2x **S970** Drum Rim Pickup Microphones

Description	Code	Price (Ex VAT)
SD700	449-090	£124.17

SD800

Contains

- 1x **SD101** Bass Drum Microphone
- 4x **S930** Instrument Microphones
- 3x **S900** Studio Percussion Microphones

Description	Code	Price (Ex VAT)
SD800	449-100	£145.83

Individual microphones shown on pages 100 and 101.

SD700



SD800



STUDIOSPARES

Studiospares SD705/SD805

Drum Microphone Kits

A carefully selected group of microphones, each the finest for their particular application.

Two self contained kits each designed for slightly different microphone techniques. Housed in a carry case with cutouts to ensure the kit is complete when clearing up after a session.

SD705

Contains

- 1x **SD106** Bass Drum Microphone
- 2x **S935** Instrument Microphones
- 2x **S980** Overhead Percussion Microphones
- 3x **Mic clips**, 2x **Overhead mic clips**, 2x **Overhead foam windshields**.

Description	Code	Price (Ex VAT)
SD705	449-650	£49.17

SD805

Contains

- x **SD106** Bass Drum Microphone
- 4x **S935** Instrument Microphones
- 2x **S980** Overhead Percussion Microphones
- 5x **Mic clips**, 2x **Overhead mic clips**, 2x **Overhead foam windshields**.

Description	Code	Price (Ex VAT)
SD805	449-660	£64.17

Individual microphones shown on pages 99 and 101.

SD705



SD805



STUDIOSPARES

Sennheiser e600

Drum Mic Kit

This 7-piece kit offers everything you need to professionally mic a full drumkit.

- 4x e604 is Sennheiser's classic snare and tom-tom dynamic mic
- 2x e614 condenser mic
- 1x e602-II Bass drum mic
- 1x aluminum case with die-cut foam



Description	Code	Price (Ex VAT)
e600	473-650	£662.50

Shure PG DMK4/6

Drum Microphone Kits

These kits save money and time since all cables and drum mounts are housed within the carrying case.

- **PGDMK4** - Consists of 1x PG52 Kick Drum mic and 3x PG56 Snare/Tom mics
- **PGDMK6** - Consists of 1x PG52 Kick Drum mic and 3x PG56 Snare/Tom mics and 2x PG81 Instrument mics
- Massive savings over the individual prices



Description	Code	Price (Ex VAT)
PGDMK4	423-330	£226.50
PGDMK6	423-340	£282.50

Heil PR-28

Drum Microphone

A premier drum microphone designed for toms, snares, bongos and percussion.

- Cardioid pick up, good rear rejection
- Frequency 55Hz - 18kHz (3dB rise @ 3500Hz)
- Capsule suspension stops unwanted vibrations
- Maximum SPL 148dB



Heil PR-48

Pro Kick Drum Mic

1.5" large diaphragm dynamic element sealed in a vulcanized shock mount and housed in a metal body.

- Specially designed low pass filter that creates a 10 dB rise from 60 to 100 Hz
- 7.5 kHz dip stops unwanted internal sounds
- Frequency 30Hz - 8.5kHz (4dB rise @ 4500Hz)
- Max SPL 148dB



Description	Code	Price (Ex VAT)
PR-28	318-020	£99.58
PR-48	318-060	£187.46

Telefunken DD4/DD5

Drum Mic Kits

Combines the three unique voices of its TEC Award winning Dynamic Series microphone line.

- **DD4 Kit:** 1x M82 (for kick drums), 1x M80-SHB (for snare), 2x M81-SH (for toms), 4x 5m XLR with right angle female connector 1x FC80 Hard Shell Flight Case
- **DD5 Kit:** 1x M82, 1x M80-SHB, 3x M81-SH, 5 meter XLR with right angle female connector 1x FC80 Hard Shell Flight Case
- Shipped with appropriate drum mounts and 5m XLR lead with a right angled female connector



Description	Code	Price (Ex VAT)
DD4	499-390	£832.50
DD5	499-400	£992.68

Modular Microphones

AKG Blue Line

Modular Mic System

This modular range of electret microphones has a capsule to cover all applications. Like all AKG products, precision and reliability are second to none. The new Blue Line system brings the flexibility of the modular system within the budget of practically everyone.

AKG SE300B

Universal Powering Module



- Universal Powering Module
- Connects to different mic capsules, plus a variety of accessories
- Low susceptibility to RF interference
- Operates on phantom power from 9V to 52V
- Switchable -10dB pre attenuation
- Switchable bass cut filter

AKG CK91 Cardioid Capsule

Cardioid Capsule with classic studio polar pattern requirement. Sounds originating behind the capsule are suppressed.

AKG CK92 Omnidirectional Capsule

Transparent sound with freedom from proximity effects. Outside broadcast reporters can capture every sound.

AKG CK93 Hypercardioid Capsule

Similar in design to the CK91 but provides additional rejection of sounds arriving from 90 degrees off axis. Effective in many live sound situations.

AKG CK94 Figure of 8

Popular for drama recordings and interviews. Used with a cardioid, the CK94 can form an M/S stereo configuration.

AKG CK98 Short Shotgun

Provides a narrow polar pattern for film and stage work with a 6dB increase in sensitivity. Includes W98 Foam Windshield.

Description	Code	Price (Ex VAT)
SE300B + CK91	419-000	£215.00
SE300B	419-010	£147.50
CK91 Cardioid	419-020	£147.50
CK92 Omni	419-030	£147.50
CK93 Hypercardioid	419-040	£147.50
CK94 Figure of 8	419-050	£330.43
CK98 Short Shotgun	419-090	£252.00

AKG Micromic Series

The AKG Micromic series of Condenser Microphones is a modular system with an advanced performance. There are obvious differences between microphones designed to be used down the bell of a trombone and those suited to a violin. Phantom Power versions connecting lead terminates in a Male XLR which houses the electronics to drive the microphone from a Phantom Powered microphone input. Mini XLR versions require a B29L described below to provide the 9 volt powering voltage.

AKG B29L

Control Unit

- Requires a PP3 battery (not supplied) to provide power for the microphone
- 2 mic inputs on mini XLRs and one standard XLR output
- Both input levels are adjustable
- Approximately one year battery life



AKG C411L For Acoustic Instruments

Vibration pickup that can be fixed to the instrument body. Captures the entire frequency spectrum of the instrument. Suits acoustic string instruments.

AKG C516ML Instrument Microphone

Hypercardioid polar pattern to avoid feedback to PA systems. Complete with H416 installation plate, adhesive rubber plate, adhesive putty and W44 Windscreen.

AKG C417L Lavalier Microphone

Omni directional pick up pattern. Optimum frequency response even when the mic is not pointing directly towards the mouth. Response is ideal for speech clarity.

AKG C518M/ML Drum/Percussion Microphone

Designed for drum and percussion miking. Increased low frequency output when close miking is compensated by a bass roll off. Punchy sound without frequency rumble.

AKG C519M/ML Wind Instrument Microphone

Designed to clamp onto the bell of the instrument. A swivel and gooseneck allows optimum placement. Includes W44 Windshield.

AKG C520/C520L Headworn Microphone

Cardioid for minimum feedback. Supported by hinged gooseneck.

Description	Code	Price (Ex VAT)
B29L	409-080	£41.60
C411L Mini XLR Version	419-640	£90.83
C516ML Mini XLR Version	439-610	£112.50
C417L Mini XLR Version	419-670	£56.00
C417PP Phantom Powered Version	419-680	£89.90
C518M Phantom Powered Version	439-620	£143.00
C518ML Mini XLR Version	439-630	£104.00
C519M Phantom Powered Version	439-640	£145.83
C519ML Mini XLR Version	439-650	£107.50
C520 Phantom Powered Version	439-660	£134.70
C520L Mini XLR Version	439-670	£137.86

PRICE
changes

This catalogue was priced on 1st December 2014.

Current prices may be higher...

see our website for up to date prices.

WANT
a job?

Are you looking for a stable and rewarding career?

Studiospares are constantly expanding. We require additional staff for a variety of positions, working in a very congenial atmosphere. Practical experience of recording and/or live sound engineering would be preferable.

send in your CV in the first instance

ALL PRICES EXCLUSIVE OF VAT.

MICROPHONES

Vocalist Microphones - Condenser

Studiospares S950 Cardioid

Vocalist Microphone

Easily responds to the intimate presence and every nuance of the human voice.

- No sibilance or edgy sounds
- Great for solo vocalists or groups/choirs
- Capsule is soft suspended
- Maximum SPL is 135dB
- Powering is via one 1.5V AA battery
- Supplied with an XLR lead



Description	Code	Price (Ex VAT)
S950 Phantom powered	449-060	£23.30

Studiospares S955 Hypercardioid

Vocalist Condenser Mic

The Electret capsule easily responds to the intimate presence and every nuance of the human voice.

- No sibilance or edgy sounds
- Great for solo vocalists or groups/choirs
- Doubles as a high quality instrument mic
- 19mm Gold Electret Capsule
- Effective double Pop Blast filtering
- Filter easily cleaned and refreshed
- Response 20Hz - 20kHz
- Maximum SPL 134dB
- Phantom powered
- Includes a microphone stand clip



Description	Code	Price (Ex VAT)
S955	449-620	£27.40

Monacor ECM-925P Supercardioid

Vocal Microphone



High sensitivity, especially suitable for outdoor recordings.

- Switchable directional characteristic, from normal to supercardioid
- Mic can be used in both distant and close up shots
- Built in on/off Switch and supplied with a foam windshield

Description	Code	Price (Ex VAT)
ECM-925P	255-560	£47.20

JTS Carbon Microboom

Auditorium Microphone

Designed to be used on stage but not seen.

- 3 alternative tiny electret capsules
- 1450mm boom on a 3 pin mini XLR plug
- Mini XLR/XLR lead is concealed within the boom arm
- Includes floor stand extending to 62cm, mic power supply and 8m cable



Description	Code	Price (Ex VAT)
Carbon Microboom	437-990	£115.83

Electro-Voice RE510

Hypercardioid Condenser Microphone

Offers the warmth of a larger capsule design without sacrificing off-axis performance or transient response.

- Super cardioid polar pattern
- 16mm self biased capsule
- Low-frequency roll-off switch
- Maximum SPL (1% THD) 140 dB
- Frequency Response 40 - 20,000 Hz
- High-compliance shock mount effectively eliminates handling noise
- Tight-mesh Memraflex grille
- Multistage pop filter



NEW

Description	Code	Price (Ex VAT)
RE510	414-030	£190.00

Electro Voice RE410

Vocalist Condenser Microphone

Optimised to capture the human voice in professional club and concert sound as well as studio recording.

- Provides crisp, clear top-end and sweet mid-range
- Premium-grade handheld condenser
- Cardioid pattern for excellent feedback rejection and acoustic isolation
- Ideal for both singing and spoken word
- Tight-mesh Memraflex™ grille
- Multistage pop filter



Description	Code	Price (Ex VAT)
RE410	414-020	£115.83

Rode iXY Lightning

Stereo Microphone for iPhone and iPad

The ultimate recording microphone for iPhone and iPad.

- Record stereo audio at 24-bit, 96kHz*
- Matched pair of 1/2" cardioid condenser capsules
- Metal casing for enhanced durability and electromagnetic interference immunity.
- Includes windshield, zip case
- Software-switchable 72Hz high pass filter
- Compatible with iPhone 5/5s/5c, iPhone 6 and iPhone 6plus



NEW

Description	Code	Price (Ex VAT)
iXY Lightning	497-280	£115.83

IK iRig Mic Cast

Mobile Microphone

An ultra-compact, portable voice recording microphone designed specifically for recording podcasts, interviews, lectures etc

- Hi-Lo recording level switch
- Headphone output
- Includes an adjustable desktop stand
- 2 free apps: iRig Recorder, and Vocalive



Description	Code	Price (Ex VAT)
iRig Mic Cast	321-520	£20.82

Stageline FSM-170

Dual Application Floor Stand Microphone

Consists of 2x different length vertical telescopic shafts, 1.46m carbon fibre boom arm and 3x back electret capsules.

- Incredible versatility for front of stage or overhead applications. Heavy base.
- Capsules, cardioid, omni and hypercardioid
- 2x shafts 90-160mm and 39-63mm
- Lead plugs into the end of the boom arm
- -10dB attenuator in Mini XLR plug
- 8m Mic cable. Mini XLR to XLR
- Capsules screw into boom arm



Description	Code	Price (Ex VAT)
FSM-170	256-410	£107.50

Lewitt MTP340

Handheld Condenser Microphone

Brings a high level of sonic detail to demanding vocal applications.

- Frequency range 90-20,000 Hz
- Sensitivity 3.1 mV / Pa (-50 dBV)
- Maximum SPL 141 dB, 1% THD
- Frequency range 90 ... 20,000 Hz
- Uniform cardioid pickup pattern for minimum off-axis coloration
- High gain before feedback
- Easily withstands high sound pressure levels
- Integrated windshield offers excellent protection against plosives and sibilance
- Convenient recessed on/off slide switch
- Including MTP 40 MCs shock mount and DTP 40 Lb artificial leather bag



NEW

Description	Code	Price (Ex VAT)
MTP340	456-210	£108.33

MICROPHONES

Vocalist Microphones - Dynamic

Heil The Fin

Vocal Stage Microphone

Combines that "vintage mic look", with a blend of futuristic, and TIMELESS in one shiny microphone.

- In the studio or live it exhibits good upper mids
- Response 50Hz - 18kHz.
- Mid range "bouquet" at 4 kHz, which presents incredible brilliance and presence
- Low mass diaphragm element driven by a powerful magnet
- Cardioid polar pattern
- Steel body is triple chrome plated



Description	Code	Price (Ex VAT)
The Fin Chrome/Blue	318-070	£161.50
The Fin Chrome/Red	318-075	£183.29

PRICE match

Studiospares will BEAT any genuine price from any UK competitor on any item or order.

details on page 318

DELIVERY BEFORE NOON
no problem

SATURDAY DELIVERY
no problem

Audix BP5PRO

Stage Mic Kit

A combinations of VLM™ dynamic microphones designed to work in tandem for instruments and vocals in a live performance.

- Includes 1x i5 snare drum mic, 1x D6 kick drum mic, 2x OM5 lead vocal mics, 4x MCI mic clips and 1x DCLIP mic clip



Audix BP7PRO

Stage Mic Kit

Expanded complement of mics.

- Includes 3x i5 snare drum mic, 1x D6 kick drum mic, 2x OM2, 1x OM5 lead vocal mics, 6x MCI mic clips and 1x DCLIP mic clip



Description	Code	Price (Ex VAT)
BP5PRO	422-980	£382.50
BP7PRO	422-990	£482.50

Telefunken M80

Vocal Microphone

Featuring a wider frequency response and higher SPL capabilities, the M80 delivers condenser-like performance in a rugged dynamic design

- Capsule assembly designed to reduce proximity effect to which nets added low end clarity for vocals
- A tight cardioid pattern with good rejection of sound from the rear
- Presence peak is fairly wide and gentle
- American made custom wound impedance matching transformer



Telefunken M81

Vocal Microphone

A clear and detailed top end, articulate mid-range, and minimal proximity effect.

- The top end is pulled back a bit, yielding a flatter overall frequency response
- Good for taming brighter vocals and guitar tones and for fattening up percussion, horns and thinner sounding sources
- Cardioid pickup pattern. 30Hz - 18kHz
- Includes wooden box, additional black head grille, mic clip



Telefunken M82

Vocal Microphone

A robust dynamic cardioid microphone that features a large 35mm diaphragm with superb low frequency capabilities.

- Very high SPL
- Two EQ switches: KICK EQ & HIGH BOOST
- KICK EQ engages a filter reducing lower mid-range frequencies (centered around 350Hz)
- HIGH BOOST tilts the upper mid-range and high frequencies around 2kHz with a 6dB boost by 10kHz.
- Great when used inside a M805H, kick drum
- Response 25Hz - 18kHz. SPL 160dB



Description	Code	Price (Ex VAT)
M80	499-320	£175.00
M81	499-330	£175.00
M82	499-340	£265.00

MXL CR77

Stage Dynamic Microphone

Merges vintage style with modern design elements both inside and out.

- Integrated foam windscreens
- Super cardioid polar pattern
- Shockmount to reduce noise from floor vibrations
- Rugged construction
- Sleek black and chrome body
- Frequency Response: 50 Hz-14 kHz
- Polar pattern: Super Cardioid
- Sensitivity: -52 dB re 1 V/Pa
- Traditional 1960s appearance



Description	Code	Price (Ex VAT)
CR77	315-280	£124.17

AKG D5

Stage Vocal Microphone

The D5 dynamic vocal microphone for lead and backing vocals delivers a powerful sound even on the noisiest stage

- Crisp sound that cuts through every mix
- Dual shock mount eliminates any kind of mechanical noise
- Supercardioid polar pattern



Description	Code	Price (Ex VAT)
D5	439-730	£57.50
D5 + 5m Pro Lead + Mic Stand	439-735	£69.99
D5 + 10m Pro Lead + Mic Stand	439-736	£74.17

Behringer Ultravoice XM8500 Cardioid

Vocal Dynamic Microphone

The XM8500 provides a good healthy frequency response of 50Hz to 15kHz, and includes a two-stage pop filter to minimize breath and pop noises.

- Cardioid characteristic cuts background noise and feedback
- Smooth mid-frequency presence rise



Description	Code	Price (Ex VAT)
XM8500	381-120	£16.63

Behringer Ultravoice XM1800S Cardioid

Vocal Microphone

Dedicated vocal and instrument mic with on/off switch which delivers excellent quality for your studio and live performance

- Wide frequency response for a brilliant and transparent sound
- On/off switch to mute during breaks
- Stand adapter and carrying case included



Description	Code	Price (Ex VAT)
XM1800S 3-Pack	381-130	£21.67

Shure SM58 LC Cardioid Vocalist Microphone

Easily the world's most popular and most copied stage microphone.

The SM58 is guaranteed to enhance any artist's performance through the punchy and dynamic sound. The capsule is elastically suspended to minimise shock and handling noise. The pick up pattern is cardioid which helps reduce unwanted feedback enabling the performer to increase the level of the PA. The frequency response is tailored to the vocal spectrum with a range 50Hz to 15kHz. The Wire Mesh pop shield minimises breath and popping noises and can be removed for cleaning or replacement.

- Cardioid (unidirectional) dynamic
- Pneumatic shock-mount system
- Uniform cardioid pickup pattern
- Frequency response: 50 to 15,000 Hz
- Built-in spherical wind and pop filter
- Supplied with break-resistant stand adaptor and storage bag
- Bundle option with either a Pro or Economy XLR Lead

Description	Code	Price (Ex VAT)
SM58 LC	423-011	£79.17
SM58 LC 3-Pack	423-013	£228.50
SM58 LC + 5m XLR Lead	423-014	£81.33
SM58 LC + 10m XLR Lead	423-015	£82.83
SM58 LC + Pro 5m XLR Lead	423-016	£88.33
SM58 LC + Pro 10m XLR Lead	423-017	£91.33
SM58 LC + 5m XLR Lead + Mic Stand	423-020	£82.50
SM58 LC + 10m XLR Lead + Mic Stand	423-021	£85.00
SM58 LC + Pro 5m XLR Lead + Mic Stand	423-018	£93.33
SM58 LC + Pro 10m XLR Lead + Mic Stand	423-019	£97.33
SM58 On/Off Switched version	423-100	£82.50
Optional STA4 Adaptor	401-100	£3.90
Protective Grille	404-741	£8.94



First introduced in 1966, the SM58 remains one of the best selling microphones in the world today.

MICROPHONES

Vocalist Microphones - Dynamic

CONTINUED

Studiospares S1940

Cardioid Retro Microphone

The S1940 looks great and quickly becomes part of the act.

Recreating the sounds of the 40s and 50s starts at the microphone. It even feels 1940s. Manufactured from a zinc die casting which houses a large dynamic capsule heavily protected from pop and blast by the slots which break up blasts whilst an internal red foam windshield filters out the rest. To be really authentic there is a slight presence peak which provides greater intelligibility and clarity. The On - Off switch is silent and will not "pop the monitors" when activated. The S1940 is capable of withstanding the rigours of the stage and the road. Includes a sturdy microphone case. Bundle includes round-based chrome stand and an armoured XLR lead.

Description	Code	Price (Ex VAT)
S1940	449-140	£47.08
S1940 Bundle	449-145	£64.50



Shure Super55 Supercardioid

Dynamic Microphone

This supercardioid dynamic vocal microphone combines the vintage design of the original icon, with a contemporary upgrade in audio performance. Includes an integrated, swivel stand mount.

- Frequency response 50Hz to 15kHz
- Super cardioid pick up excludes unwanted sounds from the rear



Description	Code	Price (Ex VAT)
Super55	433-190	£175.00

Retro Vocal Mic Cardioid

Vocalist Microphone

This Retro Microphone conjures up the nostalgia of the 50s and 60s. Response tailored to fit that era.

- Cardioid response for reduced feedback
- On-Off switch
- Foam padded case
- Chromium-plated body
- Frequency range 50-16,000Hz



Description	Code	Price (Ex VAT)
Retro Vocal Mic	401-790	£32.80

Studiospares S1945

Vocal / Harmonica Microphone

Captures every nuance of the harmonica which is very rich in harmonics.

- For reproducing the harmonica the S1945 is almost impossible to beat
- Chrome finish captures the realism of the 1940s era
- Very popular with harpists
- Angle adjustable
- Sold at a fraction of the price of competitive products



Description	Code	Price (Ex VAT)
S1945	449-740	£41.50

AKG P5 Perception

Live Microphone

A dynamic handheld mic for lead vocals. The super cardioid polar pattern guarantees for utmost gain before feedback and makes the voice cut through the mix more easily.

- Super cardioid polar pattern designed for lead vocals
- With stand adapter and zip bag
- Internally protective wiremesh cap



Description	Code	Price (Ex VAT)
P5 Perception	439-980	£32.50
P55 Perception Switch Version	439-990	£37.50

Shure SV100

Vocal Dynamic Microphone

The Shure SV100 can be used for karaoke, sound reinforcement and multimedia applications.

- Wide frequency response
- Unidirectional pickup pattern
- High output
- Clear and vibrant sound
- Suitable for instrument pickup



Description	Code	Price (Ex VAT)
SV100	423-840	£24.00

Shure 555H Cardioid Series 11

Vocalist Microphone

Shure 555H series 11A is a classic microphone with a nostalgic appearance. Artists feel the synergy between themselves and the 50s and 60s era when performing with the 555H.

- Frequency response 50Hz to 15kHz
- Cardioid pick up reduces unwanted sounds from the rear



Description	Code	Price (Ex VAT)
555H	423-190	£115.83

Audio Technica ATM610a

Hypercardioid Vocal Microphone

Tuned for clear, detailed, extended-range reproduction of lead and backup vocals.

- Rare-earth magnet for articulate vocal reproduction
- Frequency Response: 40-16,000 Hz
- Multi-stage grille design offers excellent protection against plosives and sibilance
- Accessories: Quiet-Flex® stand clamp for 5/8" threaded stands; 5/8" to 3/8" threaded adapter; soft protective pouch



Description	Code	Price (Ex VAT)
ATM610a	447-830	£107.50

Audio Technica ATM510

Vocal Microphone

A cardioid dynamic workhorse which is designed for smooth, natural vocal reproduction which cuts through the mix.

The microphone features super-durable construction for long-lasting performance, a rare-earth magnet for high output, and a multi-stage grille design for excellent protection against plosives. Its cardioid polar pattern reduces pickup of sounds from the sides and rear, maximizing isolation from other sound sources and minimizing feedback. Equipped with newly designed internal shock mounting for reduced handling and stage noise.

Supplied complete with pouch, stand clamp and threaded adaptor.

Description	Code	Price (Ex VAT)
ATM510	447-790	£65.83



FOR
fax orders
 Use our fax number...
020 8450 4390

THE
website
 Keep up to date with all the latest products and current prices on the Studiospares website!
check out www.studiospares.com

Studiospares S965

Female Vocalist Microphone

Gives good account of itself whatever the situation.

The frequency response is tailored to slightly enhance mid and upper frequencies. The pickup pattern is hypercardioid so problems of acoustic feedback when venturing near speakers are drastically reduced. A dual pop blast filter reduces the incidence of pop blast from over enthusiastic performers. Both filters can be easily refreshed by simply unscrewing the protective grille. The capsule is soft mounted to reduce any handling noise from nervous performers. Although this model is sold as a vocalist microphone it doubles equally well as an instrument microphone finding frequent applications such as being close to the bell of a saxophone, miking acoustic guitars or in front of a speaker cabinet.

Specification. Frequency response 50Hz - 15kHz. Maximum SPL 144dB.

Description	Code	Price (Ex VAT)
S965	449-640	£18.75
S965 - 3 Pack	449-643	£47.00
S965 - 10 Pack	449-641	£149.00
S965 + Stand	449-645	£25.70
S965 + Stand + 5m XLR Lead	449-646	£29.50



Studiospares S1970

Gold Vocalist Microphone

Specifically designed to complement the female vocalist who needs outstanding quality and a microphone she can feel comfortable with.

To capture the natural nuances of the female voice a prepolarised electret capsule was selected. Moisture from the breath can cause havoc with earlier externally polarised condenser capsules and the ruler flat response, particularly at mid and high frequencies is essential for a natural sound. Only 19mm diameter and 108mm long. Frequency response 20Hz - 20kHz. Cardioid pickup pattern. Maximum SPL 135dB. Includes a stand clamp, foam windshield and pouch.



Description	Code	Price (Ex VAT)
S1970	449-940	£57.50

Studiospares S960

Vocalist Microphone

Designed to provide "Punch" to any vocalists act

- Doubles as an instrument mic finding particular favour for close miking of brass and stringed instruments
- Capsule is soft mounted to stop handling noise
- Stainless grille and internal foam windshield protects from pop blast from over-enthusiastic performers
- Die cast metal body with On-Off switch
- With 4 metre XLR to Jack lead



Description	Code	Price (Ex VAT)
S960	448-610	£17.80
S960 - 10 Pack	448-611	£149.00
S960 + Studio Mic Stand	448-615	£24.70

Shure Beta 57A

Cardioid Vocal Microphone

Updated for optimal warmth and presence.

- The grille has been restyled and hardened, allowing engineers to place the microphone closer to the sound source
- Shock mount further reduces handling noise
- Finds frequent use amongst female vocalists, particularly in backing groups
- Supplied with Mic Holder with 5/8" Thread



Description	Code	Price (Ex VAT)
Beta 57A	423-170	£95.00
STA4 Thread Adaptor	401-100	£3.90

Live M10

Vocalist Microphone

A "no compromise product" bringing quality sound to all vocalists and musicians.

Featuring a frequency response tailored to provide clarity of vocal and designed to not accentuate sibilant voices, the LIVE M10 is a high quality dynamic vocal microphone designed for professional applications. Beefs up the sound from weaker voices. High output and warm, even sound is ideal for stage performers, providing a high degree of clarity in the mix. Excellent off-axis rejection makes it very good at defeating feedback and avoiding squeals. Frequency response of 50Hz - 15kHz is ideal for male and female vocalists. Metal body provides good screening against electrical interference. Clearly marked switch allows performers to quickly check and adjust the On/Off status of the mic. Purchased by the container load and sold direct to end user, hence the very low price. Stands up extremely well against microphones costing several times its price.

Description	Code	Price (Ex VAT)
M10 Switched	449-750	£8.30
M10 3-Pack + Case/Clips	449-753	£24.99
M10 + Stand + 5m XLR Lead	449-755	£20.83

M10 Bundle



Shure Performance PG58

Cardioid Vocal Microphone

Part of their Performance Gear range, the PG58 is designed for vocalists and backing groups.

- More defined around the mid/high range which gives presence and helps to "cut through the mix"
- Overall response 60Hz to 15kHz
- Capsule protected by a steel mesh grille which surrounds a foam pop blast/wind shield
- Supplied complete with a 4 metre XLR connecting cable and stand mounting holder with a 5/8" thread



Description	Code	Price (Ex VAT)
PG58	423-280	£44.99
STA4 Thread Adaptor	401-100	£3.90

Shure Beta 58A

Vocal Microphone

Features a neodymium magnet assembly which produces a 3dB higher output level.

- The length of the magnetic field is also increased to ensure the coil stays within the field even when driven hard by high SPLs
- This increase in sensitivity can be useful where the microphone is distant from the sound source
- Includes a revised shock mount
- Supplied with Mic Holder with 5/8" Thread.



Description	Code	Price (Ex VAT)
Beta 58A	423-160	£124.17
STA4 Thread Adaptor	401-100	£3.90

VISIT
our trade counter

You'll get friendly advice and immediate access to 8000+ product lines!

SATURDAY DELIVERY
no problem

DELIVERY BEFORE 10AM
no problem

ALL PRICES EXCLUSIVE OF VAT.

MICROPHONES

Vocalist Microphones - Dynamic

CONTINUED

Shure PG48-QTC Cardioid

Vocal Microphone With XLR/Jack Lead

Cardioid polar pattern mic with durable metal construction.

- Frequency response tuned specifically for vocal applications
- Cardioid polar pattern
- Cartridge includes a neodymium magnet for high output level
- Steel mesh ball grille with integral filter



Shure PG58-QTR Cardioid

Vocal Microphone With XLR/Jack Lead

Frequency response tuned specifically for vocal applications.

- Cardioid polar
- Cartridge includes a neodymium magnet for high output level.
- Internal shock mount for reduced handling noise
- On/off switch for onstage control



Description	Code	Price (Ex VAT)
PG48-QTC	423-850	£29.90
PG58-QTR	423-860	£41.50

Studiospares S940

Cardioid Quality Dynamic Microphone

As a vocal microphone this model compares favourably with models costing five times more.

The neodymium magnet assembly is coupled to a very lightweight diaphragm that easily responds to transients and provides an output capable of pushing any system noise well out of earshot. The capsule captures the nuances of male and female vocalists alike. Musically the output is faithful and will capture stringed and brass instruments with an uncanny accuracy. The transparency also retains the pureness of reed and woodwind instruments. The capsule in the S940 sounds particularly sweet and has been described as a 'smoothie'. Male vocalists will be pleased to hear that low frequencies will be enhanced when used close up. The diaphragm is protected from the excesses of the outside world by a stainless steel mesh and an internal foam windshield. The body is not plastic but of die cast zinc which provides excellent screening against hum and RF interference. The general 'feel' of the microphone inspires confidence. The On-Off switch is of the 'lite touch' variety.

Lifetime guarantee. Manufactured in accordance with Quality standard IS09001.

Supplied complete with a 4 metre XLR to Jack lead.

Description	Code	Price (Ex VAT)
S940	448-600	£22.50
S940 - 3 Pack	448-603	£59.99
S940 + Mic Stand + Mic Clip	448-605	£33.30



Studiospares S945

Hypercardioid Quality Dynamic Microphone

The general 'feel' of this quality microphone inspires confidence.

The neodymium magnet assembly is coupled to a very lightweight diaphragm that easily responds to transients and provides an output capable of pushing any system noise well out of earshot. The capsule captures the nuances of male and female vocalists alike. Musically the output is faithful and will capture stringed and brass instruments with an uncanny accuracy. The transparency also retains the pureness of reed and woodwind instruments. The capsule in the S945 sounds particularly sweet and has been described as a 'smoothie'. The diaphragm is protected from the excesses of the outside world by a stainless steel mesh and an internal foam windshield. The body is not plastic but of die cast zinc which provides excellent screening against hum and RF interference. The On-Off switch is of the 'lite touch' variety.

Specifications.

Frequency response: 50Hz - 15kHz

Sensitivity: -53dB

Max SPL: 144dB

Description	Code	Price (Ex VAT)
S945	449-630	£19.90
S945 - 3 Pack	449-633	£47.00
S945 + 5m XLR Lead	449-635	£21.90
S945 + Mic Stand + 5m XLR Lead	449-636	£29.50



Electro-Voice N/D 767A

Handheld Dynamic Vocal Microphone

The singer and engineer's first choice for outstanding vocal clarity in live performance.

- With low handling noise, VOB™ technology, and excellent clarity through all frequencies
- Supercardioid polar pattern
- Dynamic, high-sensitivity neodymium element
- Frequency Response 35 - 22kHz
- Finish Non-reflecting Black
- Tight-mesh Memraflex™ grille
- Multi-stage shock mount



Description	Code	Price (Ex VAT)
N/D 767A	414-000	£70.83

Electro-Voice N/D 967

Handheld Dynamic Vocal Microphone

The N/D967 is the highest gain-before-feedback performance vocal microphone on the market.

- Supercardioid polar pattern
- Vocal personality switch to shape the sound
- NORMAL provides a smooth and slightly rising response
- PRESENCE provides mids slightly attenuated for clarity
- Frequency response 50Hz 13kHz
- A washable grille screen and two-stage pop filter to reduce noise



Description	Code	Price (Ex VAT)
N/D 967	414-010	£107.50

Shure SM7B Cardioid

Vocal Microphone

A smooth and warm sounding microphone that is ideal for close-talk applications such as radio presenting and voiceovers for TV.

- Dynamic mic with cardioid pattern
- Frequency response 50Hz - 20kHz
- Used for vocals on numerous albums
- Features shielding from electromagnetic hum



Description	Code	Price (Ex VAT)
SM7B	423-880	£262.50

VISIT
our trade counter
You'll get friendly advice and immediate access to 8000+ product lines!

MORE PRODUCTS
online

1000s
of products
Available from stock!

Beyer TG V30d s

Vocal Microphone

The perfect introduction to the world of beyerdynamic live microphones, the dynamic TG V30ds delivers a rich, natural sound and is perfect for speaking events and vocal performances.

- Supercardioid polar pattern
- 30 - 15000 Hz frequency response
- High output level
- Noiseless on/off switch
- Includes mic clamp, XLR to XLR cable and storage bag



Description	Code	Price (Ex VAT)
TG V30d s	430-750	£29.25

Heil PR-20

Dynamic Vocal Microphone

Has a large diaphragm providing a wide frequency range, with excellent upper mids.

- Hand assembled and QC tested
- Includes Silver, Black and Gold mesh screens
- Composite (neodymium and boron) magnet
- Large low mass diaphragm
- Response 50Hz-18kHz;
- Max SPL 145dB
- PR-20UT same as PR20 but with one mesh screen



Description	Code	Price (Ex VAT)
PR-20 with Accessories	318-005	£116.62
PR-20UT Utility Version	318-000	£79.12

Heil PR-30

Professional Dynamic Vocal Microphone

Includes a hum bucking coil in addition to the shock-mounted large diaphragm to virtually run noise-free.

- 1.5" diaphragm for easy extended bass.
- Three screens, 2x wire mesh and 1x foam virtually eliminates popping and sibilance
- Response 40Hz - 18kHz
- Max SPL 146dB
- Output level -51dB
- With an adjustable cast metal mic holder in a foam-fitted box



Description	Code	Price (Ex VAT)
PR-30	318-030	£208.29

Heil PR-22

Dynamic Vocal Microphone

Delivers rich vocals, warm & accurate guitar, crisp snare drums with depth, stellar piano and shimmering cymbals.

- Includes Silver, Black and Gold mesh screens
- Very low rear sounds through a combination of special porting & phasing plug design
- Large aluminum 28mm low mass voice coil
- 50 Hz - 18 kHz frequency response
- Cardioid pickup pattern.
- Rear rejection -30dB
- Output level -55dB. Max SPL 145dB
- Foam Pop Screen included
- PR-22UT same as PR22 but with one mesh screen



Description	Code	Price (Ex VAT)
PR-22 with Accessories	318-015	£141.62
PR-22UT Utility Version	318-010	£91.62

Sennheiser e845 Evolution
Cardioid Vocal Microphone

A high quality, powerful performance vocal microphone!

From one of the most respected manufacturers, the e845 has become a genuine best seller. The extended high frequency response and super cardioid pick-up pattern cuts through high on-stage sound levels. The smooth warm tonal response with a gentle presence lift adds clarity and projection to any vocalist.

The consistent on/off axis and proximity response maintains sound quality while moving and provides greater on-stage freedom. Frequency response 40Hz - 16kHz. Full metal construction and shielding plus an effective internal shockmount system.

Supplied complete with pouch and mic clip.

Description	Code	Price (Ex VAT)
e845	452-850	£82.50



Heil PR-35

Professional Dynamic Vocal Microphone

Excellent articulation & a natural upper mid-range along with a wide smooth flat response.

- Matte black rubberised finish looks and feels good.
- Cardioid polar pattern
- Low-cut roll off switch, stops low end feed back loops.
- Large 1.5" shock-mounted hum-bucking coil reduces handling and electronic interference;
- Max SPL 140dB
- Three interchangeable colored trim rings (black, silver, and purple) and a mic clip along with a black acoustical wind screen
- Flat response from 40 Hz to 18 kHz



Description	Code	Price (Ex VAT)
PR-35	318-040	£208.29

Lewitt MTP240

Dynamic Vocalist Microphone

Perfectly suited for use in live performances and ambitious home studio recordings.

- Frequency response 60Hz - 18kHz
- Sensitivity 2 mV / Pa (-54 dBV)
- Engineered to provide exceptional clarity and detail
- A tough steel-mesh grille resists wear and abuse
- Optimised frequency response for vocal applications
- Uniform cardioid polar pattern
- Including shock mount and artificial leather bag



Lewitt MTP540

Dynamic Vocalist Microphone

Sets new standards of sound quality in both demanding studio recordings and onstage use.

- Uniform pickup pattern
- Highly shock-proof capsule
- Easily withstands high sound pressure levels
- Integrated acoustic pop shield
- Rock-solid full-metal, die-cast body
- Corrosion-resistant gold-plated 3-pin XLR output connector
- Includes a shock mount and artificial leather bag
- 60Hz - 16kHz frequency response



Sennheiser e835 Evolution Cardioid

Vocal Microphone

The e 835 is a lead vocal stage microphone specially designed to perform under pressure.

- The cardioid pick-up pattern provides isolation from other on-stage signals
- Hum compensating coil stops buzzes
- Excellent feedback rejection
- Uniform on- and off-axis response
- e835S is the Switched version



Sennheiser e835/e835S ePack

Besides the professional vocal microphone e835/e835S, the epack includes a high-quality K&M microphone stand, a 5m XLR cable, a microphone clip and a robust microphone pouch.

Description	Code	Price (Ex VAT)
e835	452-840	£65.83
e835S	455-130	£65.83
e835 ePack	473-610	£82.50
e835S ePack	473-620	£82.50

Sennheiser e945 Supercardioid

Vocal Microphone

A fully professional super-cardioid vocal microphone which cuts through the mix and offers a smooth, natural sound.

- Rugged metal body
- Advanced shock-mount design
- Consistent on-/off-axis response
- Hum compensating coil
- Includes a pouch and a mic clamp



Description	Code	Price (Ex VAT)
e945	453-820	£140.83

WANT a job?

Are you looking for a stable and rewarding career?

Studiospares are constantly expanding. We require additional staff for a variety of positions, working in a very congenial atmosphere. Practical experience of recording and/or live sound engineering would be preferable.

send in your CV in the first instance

MICROPHONES

Broadcast Microphones

Studiospares SB200 Hypercardioid

Broadcasters Microphone



Equally at home in the broadcast studio or voiceover booth. The large dynamic capsule is optimised for close talking and will not distort even under extreme conditions. The capsule exploits the air suspension technique for effective shock and vibration resistance. A hum bucking coil rejects magnetic field interference prevalent near lighting circuits. The hypercardioid capsule rejects off axis sounds particularly welcome in "anything can happen" situations. The microphone is equally suited to recording guitar or any loud instrument such as saxophones or drums. Sensitivity 33dB @ 1kHz. The Bass Roll Off switch starts to roll off at 350Hz. The Presence switch boosts frequencies between 2-4kHz. The large capsule provides a warmth which eludes even the most expensive condenser microphones. Supplied complete with an elastic suspension and aluminium case.

Description	Code	Price (Ex VAT)
SB200	449-130	£82.50
SB200 + Multipoise Mic Stand	449-135	£127.00

Electro-Voice RE20

Vocalist Microphone

The Electro-Voice RE20 is a favourite for broadcast show hosts and voice over studios.

- Integral blast and wind filter
- Uniform response between 45Hz and 18kHz
- Shielded against magnetically induced hum and noise
- Also used inside bass drums, on acoustic guitars, and more



Description	Code	Price (Ex VAT)
RE20	414-071	£365.83
3/8-5/8 Thread Adaptor	401-100	£3.90

Electro-Voice RE320

Dynamic Vocalist Microphone

A professional-grade dynamic microphone for recording and sound reinforcement applications requiring extremely low noise and the best tonal and transient response

- Tonal switches for voice and instrument purpose or bass drum applications. Cardioid response
- Still favoured by broadcasters for voice overs and commentaries.



Description	Code	Price (Ex VAT)
RE320	414-090	£207.50

Rode NTG3B

Black Broadcast Microphone



Uses an RF signal to bias the capsule to stop the effects of moisture causing problems.

- Super cardioid polar pattern
- Machined from solid brass but lightweight
- Supplied with an aluminium storage cylinder which seals against moisture when stored
- Frequency range 40Hz - 20kHz ± 2dB
- Maximum SPL 130dB. Noise 13dB-A
- Powering 48-52v phantom power
- Dimensions 255mm long, 19mm diameter

Description	Code	Price (Ex VAT)
NTG3B Black	417-555	£365.83
NTG3B Silver	417-550	£365.83

Rode Reporter

Handheld Dynamic Microphone

Designed to allow the user freedom of use, without the technique related issues.

- Omni directional dynamic capsule
- Response tailored to maximise intelligibility
- Die-cast aluminium alloy body coated in a discrete matte black anti-glare finish
- Innovative multi-layer mesh basket without the need for a bulky foam wind shield
- Supplied with a removable microphone 'flag' to accommodate high-visibility branding
- Freq range 70Hz - 15kHz
- Dimensions 272mm long x 41.5mm diameter



Description	Code	Price (Ex VAT)
Reporter	417-980	£99.17

MICROPHONES

Boundary Microphones

Studiospares SB400
Cardioid Boundary Microphone

Prevents comb filtering by keeping phase interference above the audible range.

Some applications for directional boundary mics are picking up actors' voices onstage in drama or musicals, picking up the footwork of dance troupes, picking up speech at conference tables and boardrooms and recording small musical ensembles or soloists. A smooth wide response is guaranteed by using a back electret capsule powered by phantom powering or any voltage between 9 and 52 volts. The underside of the die cast alloy body has a rubber pad to avoid stage borne interference. Output is via a mini 3 pin XLR. Supplied complete with a connecting lead for conventional 3 pin XLR inputs. The response is substantially flat from 50Hz - 20kHz. Max SPL 130dB. Designed to withstand the rigours of the road and represents incredible value for money.

Description	Code	Price (Ex VAT)
SB400	449-520	£20.80



STUDIOSPARES

Crown PCC-160

Surface Mount Microphone

Popular for attaching to walls, under grand pianos and in conference rooms.

- Directional polar pattern
- Reduced unwanted room noise
- Max SPL 120dB
- Surface-mounting creates a "half-supercardioid" polar pattern and increases directivity by 3 dB
- Frequency response (typical): 50 Hz to 18,000 Hz at 30 degrees



Description	Code	Price (Ex VAT)
PCC-160	243-190	£255.00

MXL AC-404

USB Web Conferencing Mic

Uses built-in custom circuitry to produce smooth, quiet, and professional sounding conferences, no matter where you are.

- 180-degree coverage for great sound over a wide range
- Frequency response 40Hz - 16kHz



Description	Code	Price (Ex VAT)
AC-404	315-120	£65.83

Shure Beta 91

Cardioid Boundary Microphone

Designed specifically for kick drum or bass use, the Beta 91 should add attack and punch to recordings.

- The diaphragm's moving coil is designed to stay within the magnetic flux of the Neodymium magnet assembly
- The microphone's low profile helps to eliminate the need for a stand or mounting hardware.

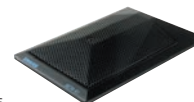

Description	Code	Price (Ex VAT)
Beta 91	423-070	£194.50

THE website

Keep up to date with all the latest products and current prices on the Studiospares website!

check out www.studiospares.com

VISIT our trade counter

You'll get friendly advice and immediate access to 8000+ product lines!

1000s of products Available from stock!

Samson UB1

Boundary Microphone

Miniature, low-profile surface mount condenser microphone.



The Samson UB1 features an omni directional pick-up pattern and USB output. Since the UB1 is a class compliant USB device, it is plug and play compatible with Macs and PCs. It ships with Cakewalk's Sonar LE, and comes with a 2m USB cable and a durable storage case. The mic is ideal for placing on a conference table, podium, or altar and can also be mounted using its keyhole mounting points. Recording at 16-bit, 44.1kHz - 48 kHz. It has a solid zinc body with a Black finish and sturdy steel grille.

Description	Code	Price (Ex VAT)
UB1	388-480	£58.32



Studiospares SB450USB

Boundary Microphone

A highly sensitive USB Boundary Electret Microphone with a multitude of applications.

- USB output OK for Mac and PC computers
- Highly sensitive back Electret capsule captures sounds from all directions
- Subsonic filter to remove troublesome frequencies that exist close to walls and floors
- Supplied with 3m of cable



Description	Code	Price (Ex VAT)
SB450USB	449-690	£24.99

Audio Technica ATR4697

Boundary Condenser Microphone

The ATR97 is a condenser boundary microphone with an omnidirectional polar pattern.

- On/off switch on bottom of microphone
- Low-profile assures minimum visibility.
- Permanently attached 1.5 m cable to a Mini Jack plug and 1/4" adaptor.
- Connects directly to a PC Soundcard



Description	Code	Price (Ex VAT)
ATR4697	447-110	£21.27

Audio Technica Pro45

Hanging Condenser Microphone

The Pro45's high-SPL handling is perfect for suspension over choirs and orchestras.

- Offers versatile sound-reinforcement solutions for speech, theater, orchestra and choir sound reinforcement and recording
- Robust construction and unobtrusive appearance



Audio Technica Pro49Q

Gooseneck Microphone

Same capsule as Pro 45 but goose-neck mounted and includes self contained electronics.

- Quick-mount double-gooseneck cardioid condenser microphone
- Designed to plug into any standard XLR-type surface or cable connector
- Flat, smooth frequency response and self-contained electronics
- Quiet, fixed-placement, long-life gooseneck
- Wide-range condenser element with low-mass diaphragm for superior performance



Description	Code	Price (Ex VAT)
PRO45	447-120	£81.67
PRO45W White	447-125	£111.00
PRO49Q	447-130	£83.29

Audio Technica U859QL

Gooseneck Microphone

Designed to plug directly into a panel or desk-mounted XLR-type connector, the U859QL features an ultra-flexible small-diameter gooseneck and a fixed cardioid element.

- Built in low cut filter removes unwanted airborne or deskborne noise
- Quick-mount design with 3-pin XLRM-type connector
- Phantom powering 11-52v DC
- Frequency response 100Hz - 16kHz
- Length 480mm



Description	Code	Price (Ex VAT)
U859QL	447-710	£129.17

Monacor MCE-100

Electret Microphone Capsule

Omnidirectional characteristic, subminiature version, PCB mounting, pin spacing 2.5.

- Frequency range 50-10,000Hz
- Power supply 1.5-10V DC - 0.5mA
- 5.6mV/Pa/1kHz, RL=2.2kΩ



Monacor MCE-101

Electret Microphone Capsule

Omnidirectional characteristic subminiature version, 150mm connection cable.

- Frequency range 50-10,000Hz
- Power supply 1.5-10V DC - 0.5mA
- 5.6mV/Pa/1kHz, RL=2.2kΩ



Monacor MCE-4500

Electret Microphone Capsule

High-quality subminiature cartridge for standard microphones, omnidirectional characteristic.

- Frequency range 20-16,000Hz
- Sensitivity 6.3mV/Pa/1kHz, ±3dB
- Diameter 6mm



Monacor MCE-4000

Electret Microphone Capsule

Extended response subminiature electret microphone cartridge omnidirectional characteristic.

- Frequency range 20-20,000Hz
- Sensitivity 5mV/Pa/1kHz, ±3dB
- Power supply 1.5-10V DC current /0.5mA



Monacor MCE-404U

Electret Microphone Capsule

High-quality back electret microphone cartridge, cardioid characteristic.

- Frequency range 100-16,000Hz
- Sensitivity 3.2mV/Pa/1kHz, ±3dB
- Power supply 1.5-10V DC current /0.5mA



Monacor MCE-400

Electret Microphone Capsule

Extended response subminiature electret microphone cartridge omnidirectional characteristic.

- Frequency range 100-16,000Hz
- Sensitivity 3.2mV/Pa/1kHz, ±3dB
- Power supply 1.5-10V DC current /0.5mA



Monacor MCE-401

Electret Microphone Capsule

High-quality electret mic cartridge, omnidirectional characteristic.

- Frequency range 50-16,000Hz
- Sensitivity 7.9mV/Pa/1kHz, ±3dB
- 1-2.2kΩ resistor is required for AF decoupling



Description	Code	Price (Ex VAT)
MCE-100	256-290	£0.97
MCE-101	256-300	£1.15
MCE-4500	256-310	£2.31
MCE-4000	256-320	£1.41
MCE-404U	256-330	£3.02
MCE-400	256-340	£1.06
MCE-401	256-350	£1.33

MICROPHONES

Installation Microphones

Audio Technica U841A

Omnidirectional Condenser Boundary Microphone

Designed for clear, highly intelligible sound reinforcement, professional recording, television and conferencing in surface-mount applications.

- Bass roll off improves sound pickup
- Foam bottom pad minimises vibrations
- Operates on battery or phantom power



Description	Code	Price (Ex VAT)
U841A	447-400	£223.33

DELIVERY BEFORE NOON
no problem

SATURDAY DELIVERY
no problem

ALL PRICES EXCLUSIVE OF VAT.

MICROPHONES

Installation Microphones

CONTINUED

AKG 99 Series

Installation Microphones

High class microphones for any application at a remarkable price point.

AKG CGN 99 C/S

Gooseneck Microphone

The cardioid polar pattern is the most popular because its uses are almost limitless. The 125 pickup angle is especially suited for inexperienced or very "vivacious" talkers who often fail to talk directly into the microphone. The choice of two different lengths and the flexible joint ensure optimum alignment of the gooseneck to any talker position. Hypercardioid version and other lengths available. See pricelist for more options.



AKG CHM 99

Hanging Choir Microphone

The CHM 99 Condenser Hanging Microphone provides both ease of use and a high level of functionality. There is hardly any more affordable and simpler solution for recording choirs at worship centers. Suspended from the ceiling or a beam, the hanging microphone is aligned and then fixed in the correct position. Now use the spring steel clamp to adjust the correct angle, and off you go! Using two CHM 99 hanging microphones in an XY configuration (coincident pair) is a good way to make stereo recordings, particularly of choirs. However, sound source locations are defined only by intensity differences. Adjusting the angle between the microphones determines the width and depth of the stereo image.



AKG CBL 99

Boundary Microphone

The CBL 99 is a high-quality boundary microphone designed to deliver superior results for a multitude of recording applications. The boundary layer technique is well-known for recording and offers non-directional pickup that is frequency independent. The CBL 99 is small, lightweight and easy to place. No stand is needed. Since the transducer sits in a metal plate only 5 mm (0.2 in) thick, the plate doesn't interfere with or color the sound. Frequency response is very uniform within its hemisphere and it captures the "room sound" of an instrument very accurately. It can be permanently attached to the floor or wall of a studio using the screw holes in the plate or attached temporarily using the supplied adhesive compound. Its 3-pin output connector also has a switchable bass-cut filter to minimize surface-born noise.



AKG DST99S

Desk Gooseneck + Base Unit

Rugged, affordable dynamic cardioid gooseneck microphone for general public address and communications use. The DST 99 S provides a frequency response tailored to speech use for optimum intelligibility as well as good offaxis rejection for high gain before feedback and suppression of unwanted ambient noise. The all-metal body ensures a long useful life for the microphone even in tough day-to-day use. The DST 99 S is mounted on a table stand with an on/off switch and coiled cable with 3-pin XLR connector.



AKG DGN99

Gooseneck Microphone with Windshield

The DGN 99 provides a frequency response tailored to speech use for optimum intelligibility as well as good offaxis rejection for high gain before feedback and suppression of unwanted ambient noise. The all-metal body ensures a long useful life for the microphone even in tough day-to-day use. Designed for permanent (single-hole or screw-on) installation and comes with a 6-ft. 4-in. (2-m) fixed, unterminated cable



Description	Code	Price (Ex VAT)
CGN99 C/S Cardioid Gooseneck 30cm	469-010	£70.00
CGN99 C/L Cardioid Gooseneck 50cm	469-020	£70.00
CGN99 H/C Hypercardioid G/Neck 30cm	469-030	£70.00
CGN99 H/L Hypercardioid G/Neck 50cm	469-040	£70.00
CHM99 Black Hanging Choir Mic	469-050	£59.99
CHM99 White Hanging Choir Mic	469-051	£70.00
CBL99 Black Boundary Microphone	469-060	£70.00
DGN99 G/neck mic with 6m cable	469-070	£70.00
DGN99E same but with XLR built in	469-080	£70.00
DST99S Desk PA Microphone	469-090	£70.00



Studiospares HM10

Hanging Condenser Microphone

The HM10 provides an unobtrusive and clear sounding way to capture audio for choral, orchestral and religious applications.

A back Electret capsule designed to be hung by it's cable. It includes a UniGuard design that makes it practically immune to RF interference. The pickup pattern is cardioid with excellent rear sound rejection. The response is 30Hz - 20kHz with a maximum SPL of 139dB. The signal/noise ratio is 70dB ref 1kHz @ 1Pa so even the quietest sound will cut through any system noise.



Description	Code	Price (Ex VAT)
HM10	449-500	£37.50

Samson CM12C

Hanging Choir Microphone

A miniature cardioid hanging microphone designed to hang directly over a choir or orchestra.

- Steel hanger positions the correct angle
- Hardwired 30-foot cable with mini XLR
- Mini to standard XLR connector included
- 9-52V Phantom Power Operation
- Condenser capsule
- Response 50Hz - 18kHz
- Max SPL 136dB



Samson CM15P/CM20P

Mini Gooseneck Podium Microphone

High-quality gooseneck microphone for any podium application.

- The condenser element and cardioid pickup pattern provide optimum sound quality for speech
- 380mm gooseneck with flexible top and bottom
- Internal Selectable Hi-pass filter
- Standard XLR connector
- Flange-mount included
- 9-52V Phantom Power Operation



Description	Code	Price (Ex VAT)
CM12C	388-860	£58.32
CM12CW White	388-861	£58.32
CM15P 15"	388-870	£58.32
CM20P 20"	388-880	£58.32
XFM1 XLR Cable Flange Mount	388-900	£12.90

MICROPHONES

Stereo Microphones

Audio Technica ATR6250 Cardioid

Camera Mountable Stereo Microphone

Two fixed charge back electrets mounted at 90 degrees to one another and yielding a response of 70Hz-18kHz

- 2 cabling options supplied on Minijacks
- Camera mount and interchangeable mic stand adaptor base included



Description	Code	Price (Ex VAT)
ATR6250	440-770	£36.67

MICROPHONES

Lavalier Microphones

Audio Technica AT831

Lavalier Microphone

Clip-on lavalier mic provides crisp, full-sounding voice pickup. The AT831R also excels as an instrument mic, especially for pickup of the acoustic guitar.

- Good gain before feedback
- Dynamic range 92dB. (106dB on AT831B)
- AT831R phantom powered only
- AT831B can powered by phantom or battery and has higher SPL of 106dB



Description	Code	Price (Ex VAT)
AT831R Mini Lapel Mic	447-350	£157.50
AT831B Clip-On Condenser Mic	447-360	£144.50

Rode Lavalier

Omni Lavalier Microphone

A discreet lavalier or lapel style mic that provides simple and intuitive audio in any application.

- Low self noise and user friendly omni polar pattern
- Minimal appearance so ideal solution for film, TV, theatres, houses of worship
- Includes mini-furry and cable management clips
- All supplied in anti-trauma water-resistant case



Description	Code	Price (Ex VAT)
Lavalier	417-770	£140.83

Sanken COS-11D

Lavalier Microphone

Sanken microphones have long been the choice of television broadcasters for their high performance and durability.

- A TA5 connection for use with compatible bodypack transmitters
- The wide frequency response, low noise and transparent audio
- Omnidirectional Polar Pattern captures every sound
- Improved mesh screen protects against moisture damage
- Frequency response 50Hz – 20kHz
- Sensitivity 28dB-A
- Ideal for professional theater, video recording, film and broadcast applications



Description	Code	Price (Ex VAT)
COS-11D	467-000	£315.00
COS-11DPT	467-010	£252.00

Trantec TS2

Lavalier Microphone

This microphone is compatible with Trantec 53.2, 53.5, 54.5, and 53500D.

- Windshield and tie clip included
- Wide flat frequency response.
- Response tailored to speech applications.



Description	Code	Price (Ex VAT)
TS2	414-241	£39.90

Rode Smartlav+

Lavalier Microphone

Can be clipped onto a shirt or jacket to provide a discreet portable recording solution.

- Pressure gradient acoustic principle
- JFET active electronics
- Omni-directional polar pattern
- 20Hz-20kHz frequency response
- -32dB re 1 Volt/Pascal (25.50mV @94dB SPL) +/- 2dB @ 1kHz
- Outputs on mini jack
- Compatible with iPhone, iPad and iPod Touch
- H 1180mm x L 4.5mm x D 4.5mm



Description	Code	Price (Ex VAT)
Smartlav+	497-290	£39.99

Audio Technica ATR3350

Lavalier Microphone

This high quality Audio Technica omnidirectional ATR3350 lavalier is engineered for intelligible, accurate voice reproduction.

- Terminates with 3.5mm Mini Jack plug
- Back Electret quality capsule
- Ideal for aerobics/dance/sports instructors
- Includes Tie clip, battery, foam windscreen, and 1/4 inch (6.35 mm) adaptor



Description	Code	Price (Ex VAT)
ATR3350	447-050	£21.75

Audio Technica PR070

Lavalier Microphone

The PR070 is designed to make music and speech clearly and comfortably audible, yet never draw attention to itself.

- Operates on battery or phantom power
- 1.8 m cable permanently attached
- Low frequency roll off 80Hz@8dB/octave
- Cardioid. Response 100-14,000 Hz
- Natural and articulate sound
- Output via XLR



Description	Code	Price (Ex VAT)
Pro70	447-720	£96.50

MICROPHONES

Video Camera Microphones

MXL FR-310 Hot Shoe

Shotgun Microphone

A comprehensive short shotgun microphone which includes all the facilities necessary to make a cameraman's life easier.

- 3 position gain switch. -5dB, 0dB, +5dB
- Bass roll off switch -6 dB/octave at 150Hz
- Integrated windscreen
- Output Connector: 1/8" (3.5mm) Mini Jack
- Standard hot shoe mount with clamp screw
- Power, AAA battery. Life up to 500 hours



Description	Code	Price (Ex VAT)
FR-310	315-260	£91.67

Rode Videomic

Mini Shotgun Video Camera Microphone



The Rode VideoMic is a professional grade condenser shotgun microphone. Based on the latest 'Film industry' technology, the VideoMic is designed specifically for use with high quality Digital Video Cameras. The microphone exhibits low noise and an unusually wide bandwidth for its size. It is ultra lightweight, yet rugged due to its AB5 construction. The VideoMic is powered by a standard 9 V battery and offers a Low Battery LED status indicator and a switchable high pass filter to reduce unwanted low frequency rumble. Battery life in excess of 100 hours. The VideoMic attaches to any Camcorder that has the standard hot-shoe fitting and utilizes a stereo Mini Jack for audio output. The integrated Rycote® Lyre shock mounting system isolates the VideoMic capsule and electronics from its all-metal shoe mount, providing isolation from external physical factors that may cause unwanted rumble and vibrations in the microphone.

Rode Dead Cat

Fits over the existing foam windshield. The DeadCat is designed for outdoor use where strong winds would generate excessive low frequencies, too much for the high pass filter to remove.



Description	Code	Price (Ex VAT)
VideoMic	417-150	£65.83
VideoMic Tripod	417-530	£21.66
Dead Cat	417-160	£24.17

Rode Videomic Pro

Compact Directional On-Camera Microphone

A true shotgun mic designed for use with camcorders, DSLR cameras and portable audio recorders as a source of primary and reference audio.

- High resolution 1/2" condenser capsule provides broadcast quality audio
- 3.5mm minijack connector
- Super-cardioid polar pattern ensures that surrounding audio is minimised
- Uses a standard shoe mount for on camera use, plus 3/8" thread for easy boom pole mounting
- Battery powered, over 70 hours recording from a single 9V battery



Rode Dead Cat VMP

A furry wind cover for the VideoMic Pro, designed for use in windy environments.

- Artificial fur specially designed to minimise wind noise
- Acoustically transparent
- Dimensions 150mmH x 95mmW x 30mmD
- Weight 13g



Description	Code	Price (Ex VAT)
VideoMic Pro	417-860	£124.17
Dead Cat VMP	417-890	£24.17

MICROPHONES

Video Camera Microphones

CONTINUED

Rode Stereo Videomic Pro

Video Camera Microphone

Perfectly suited to DSLR, consumer camcorders and large-sensor video cameras.

- Integrated shock mounting system
- Matched pair of high sensitivity 1/2" cardioid condenser capsules in a coincident XY pair
- JFET impedance converter
- Cardioid polar pattern



Description	Code	Price (Ex VAT)
Stereo Videomic Pro	417-930	£157.50

Tascam TM-2X

XY Camera Microphone

Ideal for capturing a true representation of the sonic atmosphere from a wide area or directly in front.

- Frequency response 50 Hz - 20 kHz
- Capacity to handle high sound pressures up to 120 dB SPL
- Stereo mini plug output for the camera mic input
- Floating structure reduces handling noise
- Noise isolation arm to reduce lens operation noise included
- Also includes Floating Support Structure & Furry Windscreen



NEW

Description	Code	Price (Ex VAT)
TM-2X	238-550	£65.83

MICROPHONES

E.N.G. Reporting Microphones

Rode Podcaster

USB Broadcast Microphone

Based on the Rode Broadcaster, the Podcaster is a USB output mic

- An end-address configuration
- Very low self noise
- 5m USB cable and control software via a download from the Rode web site
- For optional extras, see our website



NEW LOWER PRICE

Description	Code	Price (Ex VAT)
Podcaster	417-280	£99.73

AKG D230

Dynamic Omni Directional

The D230 is a purpose designed reporters' microphone with an extended shaft.

- A redesigned magnet assembly maintains a linear output even under high noise conditions
- The response is tailored for maximum intelligibility and extends to 16kHz



NEW LOWER PRICE

Description	Code	Price (Ex VAT)
D230	409-121	£86.67

Beyer M58NC + MCE58
Omni Directional + Applications: News Gathering

The M58NC is a purpose designed dynamic reporters' mic with an unusually long stem to provide reach in situations where many reporters may be vying for the subject's information.

By utilising an omni directional pick up pattern the M58NC can capture sounds that would otherwise be lost had the mic been facing in the wrong direction. It should not be used however in situations where the back ground noise is excessive. The capsule's sophisticated internal shock mount considerably reduces undesirable handling noise. The frequency response has been fine tuned to provide broadcasters with accurate reproduction of voice information with a high degree of intelligibility. This model also finds applications within the recording industry for its omni directional characteristic. Its response extends from 45Hz to 20kHz with a slight presence rise in the 5-8kHz region.

Description	Code	Price (Ex VAT)
M58NC	410-251	£122.40

MCE58

Based on the M58NC but with a pre-polarised back electret capsule. Sophisticated capsule suspension system to reduce wind and cable noise problems.

Description	Code	Price (Ex VAT)
MCE58	410-500	£165.80



beyerdynamic

Audio Technica AT8004

E.N.G. Reporting Microphone

The AT8004 is ideal for interviews, sportscasting and as the "mono" mic when used in conjunction with a stereo mic.

- Dynamic so insensitive to dampness
- Omni directional pickup pattern.
- With AT8405a stand clamp for 5/8"-27 threaded stands; soft protective pouch



Description	Code	Price (Ex VAT)
AT8004	447-060	£94.78

Monacor ECM-990P

Shotgun Microphone



A back electret/hypercardioid/lobe directional condenser microphone, for video and audio recordings and transmissions where direct close-talking microphone applications are impossible or undesirable.

- A 180Hz (12dB/octave) low cut filter can be switched in stopping rumble
- Size, diameter 21mm x 432mm long
- Complete with microphone windshield, clamp
- Frequency range 30-20kHz

Description	Code	Price (Ex VAT)
ECM-990P	255-540	£84.20

MICROPHONES

Highly Directional Microphones

Rode NTG1/NTG2
Short Shotgun Microphone

Popular lightweight shotgun microphones.

A wide bandwidth and controlled polar response coupled with low noise electronics make this mic ideal for all film and video work. It comes complete with windshield and mount. NTG1 is Phantom-powered and NTG2 is powered via an internal 1.5V battery or phantom power.

Description	Code	Price (Ex VAT)
NTG1	417-300	£124.17
NTG2	417-310	£132.50
WSVM Windshield	417-490	£15.41



RØDE MICROPHONES

DELIVERY BEFORE NOON
no problem

DELIVERY BEFORE 10AM
no problem

Sennheiser MKE 600

Camcorder Microphone



The MKE 600 is a camcorder microphone that can master even the toughest video sound challenges. Its high level of directivity ensures that it picks up sound from the camera direction while reliably attenuating unwanted sound coming from the sides and rear.

Description	Code	Price (Ex VAT)
MKE 600	473-560	£215.83

Beyer MCE 86

Short Shotgun Condenser Microphone



The MCE 86 is a highly versatile and light weight product intended for camera mounts, fish poles or hand held applications in studios or on location.

- Hypercardioid polar pattern
- Switchable 180Hz low cut filter (12dB/oct)
- Transformer-balanced output
- Lightweight but stable aluminium body

Description	Code	Price (Ex VAT)
MCE 86.1 for 8-48V Phantom Power	410-430	£220.80
MCE 86.1 S1 inc battery and switch	410-440	£249.00

AKG C747 MKII

Highly Directional Microphone



Picks up voices and instruments at surprising distances...

- Slim design shotgun microphone
- Designed for exacting orchestral, choir, podium, and boardroom applications
- Extended bass and high-end response
- Hypercardioid polar pattern
- Low-impedance transformerless preamp operates on 9 to 52 V phantom power
- High SPL capability

Description	Code	Price (Ex VAT)
C747 MKII	409-190	£370.83

Audio Technica ATR6550

Shotgun Condenser Microphone



AUDIO TECHNICA ATR6550 is a condenser vocal microphone for camera applications. It has a 70 - 18,000Hz frequency. This microphone works with battery power only (1.5V).

Included is a 90cm cable with a 3.5mm minijack, windscreen, and clamp batteries.

Description	Code	Price (Ex VAT)
ATR6550	447-100	£59.25

MICROPHONES

Measurement Microphones

Stageline ECM-40

Measurement Microphone

Universal electret microphone, with linear frequency response.

- Omni directional. For measuring systems and audio recordings.
- Supplied with frequency graph
- Phantom powered 12-48V DC
- Frequency range 30-18,000Hz
- Sensitivity: 5.6mV/Pa/kHz
- Dimensions: 13/19mm x 158mm
- Max. SPL 120dB. S/N ratio > 60dB



Description	Code	Price (Ex VAT)
ECM-40	256-270	£57.50

Behringer ECM8000 Omni

Measurement Microphone



The ECM8000's linear frequency response and omnidirectional polar pattern allows you to carry out measurement and alignment tasks with minimum hassle and maximum precision, making it a perfect complement for the ULTRA-CURVE PRO DSP8024 or any other real-time analyser. Its rugged construction ensures years of trouble-free use.

Description	Code	Price (Ex VAT)
ECM8000	900-033	£36.50

Studiospares MM100

Measurement/Instrument Microphone



Primarily an Ultra Linear Omni Measurement microphone used for room analysers.

- Originally adopted by the New York studio fraternity for its uncoloured sound
- Small 9.7mm capsule captures high frequencies in a linear manner
- Microphone profile designed to ensure incoming sound waves are undisturbed
- Max SPL149dB Dynamic range 130dB
- Frequency response 50Hz - 16kHz
- Power requirements 12-52v DC
- Includes Case, Windshield and suspension

Description	Code	Price (Ex VAT)
MM100	449-880	£33.00

MICROPHONES

Headworn Microphones

Rode HS1

Headset

Discreet and lightweight headset microphone that provides clean, clear and pronounced audio for any close-miking application.

- Features three axes of mechanical adjustment
- Light weight, comfortable fit, low self noise, and minimal appearance
- Omni-directional polar pattern
- Ideal for film, television, video, theatre, house of worship and live vocal performance



Description	Code	Price (Ex VAT)
HS1B Black	417-760	£182.50
HS1P Pink	417-765	£182.50

Trantec HM-22

Headworn Microphone



The Trantec HM-22 is a high quality headband microphone, which not only claims to be one of the smallest but also one of the lightest headband microphones on the planet. It has been designed to be worn around the head and to be hidden discreetly under the hair. The headband is engineered from a hard wearing nylon composite, which has been specially selected to withstand the most robust use and yet can be adjusted to fit any user's head and ear shape. The high quality microphone optimized for speech and vocals, is mounted on a boom that can be bent into shape to allow for optimum sound quality. A small membrane is inserted into the capsule housing which protects the capsule from moisture, make up and any other dirt and it can be replaced cheaply and effectively, to allow the microphone to perform consistently at its best. There are 3 variations of the Trantec HM-22 available, with different terminating plugs.

Description	Code	Price (Ex VAT)
HM22 SI22 HI-Q Pink Minijack	434-000	£119.00
HM22 TS22 HI-Q Pink Lemo 4-Pin	434-010	£136.00
HM22 X22 HI-Q Pink MiniXLR 4-Pin	434-020	£128.00

Monacor HSE-150/SK Omni

Headband Microphone

Suitable for reproducing vocals and speech for all kinds of audio transmissions. Picks up sound clearly even if not perfectly aligned.

- Skin coloured so unobtrusive.
- Grips even under strong head movement



Description	Code	Price (Ex VAT)
HSE-150/SK	255-600	£35.70

Stageline HSE-70A SK

Ultralight Earband Mic Beige

Provides voice reproduction which is almost unparalleled.

- High quality back electret capsule
- Omnidirectional characteristic
- Earband and earlobe support
- Power supply 0.8V - 5V
- 2.5mm connector



Stageline HSE-150 SK

Ultralight Headband Mic Beige

A high-quality back electret capsule of omnidirectional characteristic.

- Skin colour makes it less obtrusive
- Ergonomic design
- Turning capsule arm of adjustable length
- Windshield included
- Power supply 1.5-9 V DC



Description	Code	Price (Ex VAT)
HSE-70A/SK	258-400	£107.50
HSE-150/SK	258-410	£37.00

MICROPHONES

Speech Microphones

Studiospares
Announcer

Cardioid Gooseneck Microphone

Designed for
announcements
and speech
applications.

The capsule is a fixed charge back electret as featured in studio microphones. Because speech is interspersed with silence the output from the capsule must be high to overcome system noise. In consequence, the output is high with a sensitivity of 18mV/Pa=35dB. The response is tailored for intelligibility and extends to 19kHz. The pickup pattern is cardioid. The matching electronics are housed within the lower part of the stem. Supplied complete with a foam pop shield. XLR male output connector flush mounted to the rear. Base unit design may vary.

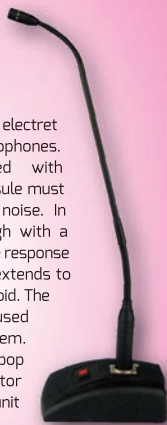

The base unit includes an illuminated On/Off switch. Powered via phantom power which powers the electronics and capsule. Complete with a mains powered Phantom Power unit. XLR output socket to the rear.

Description	Code	Price (Ex VAT)
Announcer with Base	448-520	£35.90
Announcer without Base	448-525	£19.99

AKG D58E Hypercardioid

Speech Microphone

As a purpose built Dynamic Talkback Microphone, the D58E exhibits ideal characteristics and mounts on any XLR gooseneck.

- Designed to cancel out distant sounds
- 70Hz-10kHz response tuned to speech
- Effective anti popping grille



Description	Code	Price (Ex VAT)
D58E	409-441	£82.50
W32 Optional Windshield	409-100	£7.91

Stageline PDM302

Talkback Microphone

A solid and complete system that is trouble free and simple to operate.

- Dynamic cardioid capsule.
- Freq. 60-12kHz
- Gooseneck 310mm long
- Base size mm 160L x 120W x 60H
- Impedance 600Ω
- Sensitivity 3.2 mV/Pa/1 kHz
- Complete with 5m XLR lead



Description	Code	Price (Ex VAT)
PDM302	700-113	£35.99

DELIVERY BEFORE NOON
no problem

PDM300 Cardioid

Talkback/PA Microphone



The PDM300 is a purpose built 600Ω cardioid Dynamic Microphone for foldback and PA applications. The frequency response is tailored for maximum intelligibility extending from 80Hz - 12kHz. The mic is mounted on a 192mm, 13mm diameter gooseneck. The On/Off switch has two On options, push and hold On where it will revert back to the Off position when released and a conventional On where it clicks and stays in the On position. Does NOT go hum when turned off! Supplied with 1.5m lead and 6.3mm Jack Plug.

Description	Code	Price (Ex VAT)
PDM300	401-120	£33.80

Shure Performance PG48 Cardioid

Speech Microphone

Part of their less expensive PG range, it is designed for speech applications and is based on a dynamic capsule which is tuned to provide a frequency response that gently enhances the mid range frequencies.

- Frequency response from 70Hz to 15kHz
- Includes an on off switch



Description	Code	Price (Ex VAT)
PG48	423-270	£31.66

MICROPHONES

Radio Microphones - 2.4GHz

Channel	Digital (24-bit)
Frequency	2.4GHz ISM Band
Info	Digital free from interference and licence free world wide.
Licensing	None required globally

Stageline TXS-24015X

2.4GHz Transmitter Headset/Lavalier

This system is only designed to be used with the TXS-24025ET.

- Same specification as TXS-240 SET but with 2 microphones, headset and tie clip
- Operating time > 20 hours via 2x AA batteries
- 3.5 mm plug with latching device



Description	Code	Price (Ex VAT)
TXS-24015X	256-900	£74.90

Audio Technica System 10

Digital Wireless System

Designed to provide performing musicians and presenters with advanced 24-bit operation, easy setup and clear, natural sound quality.

- Digital 24-bit/48 kHz wireless operation for ultimate sound quality and dependable performance
- 2.4 GHz range – completely free from TV interference
- Three levels of diversity assurance: frequency, time, & space
- Automatic frequency selection for interference-free operation
- Extremely easy operation with instantaneous channel selection, sync, and set-up
- State-of-the-art digital receiver for reliable performance
- Balanced XLR and unbalanced 1/4" output jacks with level control



ATW-1101



ATW-1102

Description	Code	Price (Ex VAT)
ATW-1101 Beltpack	447-850	£190.83
ATW-1102 Handheld	447-870	£194.17
ATW-T1001 Belt Transmitter	447-880	£99.00
ATW-T1002 H'held Transmitter	447-890	£107.50
ATW-R100 Receiver	447-900	£124.99

Behringer ULM Series

2.4GHz Radiomics

A 2.4 GHz digital wireless microphone system with handheld microphone and USB receiver

- Receiver feeds directly into DAWs
- VOL UP and Vol DOWN in microphone
- Panic mute facility when feedback occurs
- 8 hour battery life from 2xAA batteries
- Low battery Indication
- Dual mode analog/USB digital audio interface with automatic sensing
- Receiver dongle powered via USB interface
- Automatic pairing for easy setup



Description	Code	Price (Ex VAT)
ULM100-USB Single	383-610	£62.50

1000s
of products
Available from stock!

MORE PRODUCTS
online

Stageline TXS-2402SET

2.4GHz Handheld System

The system manages without a compander which results in an impressive dynamic efficiency and a voice transmission with a unique sound quality.

- 2 systems can be used simultaneously (corresponds to 4 mic. transmission paths)
- 16 frequencies (2,404-2,476 MHz) for each channel can be selected at the transmitter
- Digital wireless 2-channel PLL system
- Receiver with wireless auto configuration
- Operating range approx. 30 m (free field outdoors) approx. 20 m (indoors)
- Transmitter 2 x 1.5 V batt. AA size
- Microphone is super cardioid for enhanced feedback rejection



Description	Code	Price (Ex VAT)
TXS-2402SET	256-890	£124.17

AKG DMSTetrad

4 Channel Digital Wireless System



DMSTetrad Vocal Set D5

The DMSTetrad is a professional digital 2.4GHz wireless microphone system for worldwide, license-free operation. With 24bit, 48kHz audio coding, it provides uncompressed studio-quality transmission and a linear frequency response - great for uncompromising vocal and instrumental performances. With 128bit AES standard encryption to prevent tapping of the audio signal, it is also a perfect companion for high-security conferences. The DSR Tetrad receiver can work with up to four channels of audio in parallel which can be mixed down directly to its balanced XLR sum output. The entire DMSTetrad system features the DSR Tetrad digital stationary receiver, the DPT Tetrad digital pocket transmitter and the DHT Tetrad digital handheld transmitter (D5/P5). Two sets are available: the DMSTetrad Vocal Set D5 (with DHT Tetrad D5) and the DMSTetrad Performer Set (with the DPT Tetrad transmitter, a C111 L earhook microphone and the MKG L instrument cable).

Description	Code	Price (Ex VAT)
DMSTetrad Vocal Set D5	469-390	£457.50
DMSTetrad Performer Set	469-400	£449.17

Line 6 XD Series

2.4GHz Licence Free Wireless Set

All Line 6 digital wireless vocal and instrument systems are based on the 2.4GHz ISM band.

Their compander-free designs, interference-free signals and exclusive digital technologies guarantee it. 4-signal frequency diversity to ensure interference-free transmission. The three systems, V35, V55 and V75 differ in the facilities they offer, with the main differences within the receiver. All use 24-bit uncompressed audio. Of the handhelds, the V35 models a standard vocal microphone, the V55 models 4 of the most popular mics and V75 models 9 popular mics.



XD-V75L Lavalier

XD-V35

275-foot extended range; Six channels - use up to six systems simultaneously. Unlike analogue wireless systems, XD-V35 digital wireless systems never use signal companding to compress and expand the signal, so you always have full dynamic range. XD-V wireless systems allow you to convey every nuance of your performance to the audience in the most natural way, and with crystal clarity.

Description	Code	Price (Ex VAT)
XD-V35 Handheld	301-110	£165.83
XD-V35L Lavalier	301-150	£165.83



XD-V35 Handheld

XD-V55

300-foot extended range; 12 channels - use up to 12 systems simultaneously. For vocalists, performers and active spoken word presenters, the XD-V55 family sets new standards for reliability, ease of use and superior audio quality. All XD-V55 systems - both handheld and bodypack - feature patented digital technologies that deliver sound so impressive they inspire confident, great sounding performances.

Description	Code	Price (Ex VAT)
XD-V55 Handheld	301-410	£215.83
XD-V55HS Headset	301-430	£270.82
XD-V55L Lavalier	301-420	£215.83



XD-V55 Handheld

XD-V75

300-foot range; 14 always-available channels - use up to 14 systems simultaneously. Including a handheld system featuring ten superb microphone models, a lavalier system with nine EQ filter models, a headset featuring a high-end omnidirectional microphone capsule, and a bodypack unit to fit a favorite headset mic or lavalier of your own, the XD-V75 family is the right choice. The mic modeling delivers great sound, which remains pristine from your lips to your audience's ears thanks to the 24-bit performance. DCL™ (Digital Channel Lock) technology keeps your signal safe the entire time.

Description	Code	Price (Ex VAT)
XD-V75 Handheld	301-120	£324.17
XD-V75HS Headset	301-140	£324.17
XD-V75HS-T Tan Headset	301-440	£349.17
XD-V75L Lavalier	301-160	£324.17
XD-V75TR Beltpack & Receiver (No Mic)	301-450	£304.17



XD-V75 Handheld



Accessories

Description	Code	Price (Ex VAT)
TX Bodypack Transmitter for XD-V75	301-390	£116.65
XD-ADB Antenna Distribution Unit	301-530	£365.83
Spare Handheld Mic for V35 Wireless	301-540	£124.00
HS30 Headset Mic for V35 Wireless	301-560	£56.92
G50/G90 Bodypack Transmitter	301-570	£124.99
XD-V55 Handheld Transmitter	301-630	£122.49

For more accessories for the XD Series, please see our website for details.



WANT a job?

Are you looking for a stable and rewarding career?

Studiospares are constantly expanding. We require additional staff for a variety of positions, working in a very congenial atmosphere. Practical experience of recording and/or live sound engineering would be preferable.

send in your CV in the first instance

DELIVERY BEFORE NOON no problem

MICROPHONES

Radio Microphones - UHF Ch38/70

Sennheiser Evolution Wireless G3

100 Series UHF

New version of the popular high-quality wireless radiomic systems!

Designed for stage performance, the transmitter and receiver are built with durable metal housings to endure even the toughest tours. Automatic frequency management, infrared transmitter sync, and soundcheck mode make setup and operation easier than ever.

The 100 series is affordable, yet offers premium sound quality combined with features you normally only see on much more expensive systems. For musicians, presenters and reporting teams, the 100 series is a reliable partner for every situation. All G3 products are cross-compatible with the older G2 series. All systems include a power supply, antennas & batteries.



Handheld

The handheld systems include an EM100 rackmount receiver, MZQ1 Mic-Clip, there is also a choice of transmitter: Evolution dynamic 835 & 845 or condenser 865. The 845 system is also available as a more portable one where the EM100 receiver is replaced with a belt-pack EK100 receiver.

Description	Code	Price (Ex VAT)
EW135 G3 Handheld System With 835 Dynamic Mic - Ch 70	454-630	£441.70
EW135P G3 Portable Handheld System With 835 Dynamic Mic - Ch 70	454-640	£441.70
EW145 G3 Handheld System With 845 Dynamic Mic - Ch 70	454-650	£480.85
EW165 G3 Handheld System With 865 Condenser Mic - Ch 70	454-670	£552.40

Description	Code	Price (Ex VAT)
EW135 G3 - Ch 38	455-630	£441.70
EW135P G3 - Ch 38	455-640	£441.70
EW145 G3 - Ch 38	455-650	£480.85
EW165 G3 - Ch 38	455-670	£552.30

Lavalier

5 versions of the lavalier system are available. There is choice between the ME2 and ME4 microphones and like the handheld systems, there is portable versions of each. Also there is an extra ENG portable system which includes an SKP100 plug on transmitter to allow any XLR input.

Description	Code	Price (Ex VAT)
EW112 G3 Lavalier System With ME2 - Ch 70	454-590	£441.70
EW122 G3 Lavalier System With ME4 - Ch 70	454-610	£441.70
EW112P G3 Portable Lavalier System With ME2 - Ch 70	454-600	£441.70
EW122P G3 Portable Lavalier System With ME4 - Ch 70	454-620	£441.70
EW100ENG G3 Portable Lavalier/Plug-On System - Ch 70	454-580	£594.89

Description	Code	Price (Ex VAT)
EW112 G3 - Ch 38	455-590	£441.70
EW122 G3 - Ch 38	455-610	£441.70
EW112P G3 - Ch 38	455-600	£441.70
EW122P G3 - Ch 38	455-620	£441.70
EW100ENG G3 - Ch 38	455-580	£594.89

Headworn

The headworn, like the lavalier systems, has an EM100 receiver, SK100 transmitter but instead of a lavalier mic an ME3-EW headworn Microphone.

Description	Code	Price (Ex VAT)
EW152 G3 Headworn System - Channel 70	454-660	£458.72
EW152 G3 - Channel 38	455-660	£458.72

Guitar/Instrument

This system includes an EM100 receiver SK100 transmitter and a CL1 instrument cable.

Description	Code	Price (Ex VAT)
EW172 G3 Wireless Guitar System - Channel 70	454-680	£399.15
EW172 G3 - Channel 38	455-680	£399.15

Sennheiser Evolution Wireless

Accessories + Components 100/300/500 Series

Full range of accessories for the Evolution Wireless G3 Series, including microphones, transmitters and adaptors.

Wireless System (1 = 100, 3 = 300, 5 = 500)

Description	1	3	5	Code	Price (Ex VAT)
MZW1 SKM100/500 Foam Windshield	*	*	*	900-150	£11.60
ME2 Microphone	*	*	*	453-240	£77.96
ME3 Microphone	*	*	*	453-260	£109.70
ME4 Microphone	*	*	*	453-250	£82.50
NT2 Wall AC PSU	*	*	*	453-560	£24.50
GA3 Rack Kit	*	*	*	703-036	£35.00

Description	1	3	5	Code	Price (Ex VAT)
EM100 G3 Diversity Receiver Unit	*			454-690	£315.83
SK100 G3 Bodypack Transmitter	*			454-700	£203.40
EK100 G3 Portable Receiver Diversity	*			454-710	£315.00
SKM100-835 G3 Handheld Transmitter	*			454-730	£239.00
SKM100-845 G3 Handheld Transmitter	*			454-740	£259.00
SKM100-865 G3 Handheld Transmitter	*			454-750	£348.09
SKP100 G3 Plug-on Transmitter	*			454-720	£219.00
EM300 G3 Receiver Rackmount Diversity		*		454-820	£415.00
SK300 G3 Bodypack Transmitter		*		454-830	£220.43
SKM300-835 G3 Handheld Transmitter Dynamic		*		454-840	£265.00
EM500 G3 Receiver Rackmount Diversity			*	454-950	£449.00
SK500 G3 Bodypack Transmitter			*	454-960	£249.00
SKM500-935 G3 Handheld Transmitter Dynamic			*	454-970	£459.00
SKM500-945 G3 Handheld Transmitter Dynamic			*	454-980	£515.00
SKM500-965 G3 Handheld Transmitter Dynamic			*	454-990	£749.00
SKP300-G3-E-X Plug-On Transmitter		*		473-060	£296.00

Description	1	3	5	Code	Price (Ex VAT)
EM100 G3 Diversity Receiver Unit - Channel 38	*			455-690	£333.00
SK100 G3 Bodypack Transmitter - Channel 38	*			455-700	£203.40
EK100 G3 Portable Receiver Diversity - Channel 38	*			455-710	£315.00
SKM100-835 G3 Handheld Transmitter - Channel 38	*			455-730	£239.00
SKM100-845 G3 Handheld Transmitter - Channel 38	*			455-740	£259.00
SKM100-865 G3 Handheld Transmitter - Channel 38	*			455-750	£348.09
SKP100 G3 Plug-on Transmitter - Channel 38	*			455-720	£219.00
EM300 G3 Receiver Rackmount Diversity - Channel 38		*		455-820	£415.00
SK300 G3 Bodypack Transmitter - Channel 38		*		455-830	£220.00
SKM300-835 G3 Handheld Transmitter Dynamic - Channel 38		*		455-840	£265.00
SKM300-845 G3 Handheld Transmitter Dynamic - Channel 38		*		455-850	£299.00
SKM300-865 G3 Handheld Transmitter Dynamic - Channel 38		*		455-860	£375.00
EM500 G3 Receiver Rackmount Diversity - Channel 38			*	455-950	£449.00
SK500 G3 Bodypack Transmitter - Channel 38			*	455-960	£249.00
SKP300-G3-E-X Plug-On Transmitter - Channel 38		*		473-050	£296.00

Older Sennheiser Accessories

Description	1	3	5	Code	Price (Ex VAT)
GA2 Rackmount Adaptor	*	*	*	453-950	£30.71
MKE2B EW Gold-Black Evolution	*	*	*	453-990	£187.50
MKE2F EW Gold-Flesh Evolution	*	*	*	454-000	£187.50

Sennheiser eRack

Wireless Radiomic System

Channel 38 Racked system.

- A portable 19" rack unit with a rack drawer, antenna splitter, power supply unit, front mounted aerials, GA3 19" rack adapters, and pouches for handheld or beltpack transmitters



eRack + 4x EW112 ME2 Lavalier

Includes 4x Beltpack transmitters, 4x ME2 Lavalier microphones.

eRack + 4x EW122 ME4 Lavalier

Includes 4x Beltpack transmitters, 4x ME4 Lavalier microphones.

eRack + 4x EW135 835 Handheld

Includes 4x 835 Handheld mics.

eRack + 4x EW145 845 Handheld

Includes 4x 845 Handheld mics.

eRack + 4x EW165 865 Handheld

Includes 4x 865 Handheld mics.

eRack + 2x EW135 + 2x EW112 835/ME2

Includes 2 x 835 Handhelds + 2x ME2 Lavalier mics.

eRack + 2x EW135 + 2x EW122 835/ME4

Includes 2 x 835 Handhelds + 2x ME4 Lavalier mics.

eRack + 2x EW145 + 2x EW112 845/ME2

Includes 2 x 845 Handhelds + 2x ME2 Lavalier mics.

eRack + 2x EW145 + 2x EW122 845/ME4

Includes 2 x 845 Handhelds + 2x ME4 Lavalier mics.

eRack + 2x EW165 + 2x EW112 865/ME2

Includes 2 x 865 Handhelds + 2x ME2 Lavalier mics.

eRack + 2x EW165 + 2x EW122 865/ME4

Includes 2 x 865 Handhelds + 2x ME4 Lavalier mics.

eRack + 1x EW335 + 2x EW312 835/ME2

Includes 1 x 835 Handheld + 3x ME2 Lavalier mics.

Description	Code	Price (Ex VAT)
eRack ME2	473-670	£2665.00
eRack ME4	473-680	£2665.00
eRack 835	473-690	£2707.50
eRack 845	473-700	£2812.00
eRack 865	473-710	£3040.00
eRack 2x 835 + 2x ME2	473-720	£2707.50
eRack 2x 835 + 2x ME4	473-730	£2707.50
eRack 2x 845 + 2x ME2	473-740	£2749.00
eRack 2x 845 + 2x ME4	473-750	£2749.00
eRack 2x 865 + 2x ME2	473-760	£2875.00
eRack 2x 865 + 2x ME4	473-770	£2875.00
eRack 1x 835 + 3x ME2	703-130	£3330.00
eRack Rack only	473-660	£1032.50

FOR fax orders

Use our fax number...

020 8450 4390

ALL PRICES EXCLUSIVE OF VAT.

MICROPHONES

Radio Microphones - UHF Ch38/70

CONTINUED

Sennheiser XSW

UHF Wireless System

Easy-to-use, all-in-one package for singers, speakers and presenters available for channel 38 operation.

Mute button for full speech control. Synchronization via RF remote channel. Frequencies tunable in steps of 25 kHz. 24 MHz bandwidth (13 MHz for the E band). 8 frequency banks with each max 12 presets.

Handheld Dynamic. The capsule offers the legendary e 835 sound.

Handheld Condenser. Provides brilliant uncoloured sound.

Lavalier. Unobtrusive clip-on microphone. High speech intelligibility.

Instrument. Bodypack transmitter connects directly to instrument via a jack lead.

Headset. The professional ME 3 headworn microphone provides crystal-clear sound even in noisy surroundings.

Rack Mount Kit GAM1. Mounts 1 EM 10 into a 19" rack and put antennas at the frontside. BNC cables are included.

Rack Mount Kit GAM2. Mounts 2x EM 10 into a 19" rack. It also allows antenna frontmount of 2 antennas and interconnection of RF signals from antennas to the receivers. Antenna splitters and BNC cables are included.

Rack Mount Kit GAM3. Two-channel rack-mount brackets serve to install two EM 10 receivers of the XS WIRELESS series in 19" racks. Antenna splitters and cables are not included.



Description	Code	Price (Ex VAT)
XSW35 Handheld - Ch70	473-500	£249.17
XSW65 Handheld Condenser - Ch70	473-510	£290.83
XSW12 Lavalier - Ch70	473-520	£249.17
XSW72 Instrument - Ch70	473-530	£249.17
XSW52 Headmic Set - Ch70	473-540	£290.83
GAM1 Rack Mount	473-550	£149.00
GAM2 Rack Mount	473-570	£41.60
GAM3 Rack Mount	473-580	£16.50

Description	Code	Price (Ex VAT)
XSW35 Handheld - Ch38	473-000	£249.17
XSW65 Handheld Condenser - Ch38	473-010	£290.83
XSW12 Lavalier - Ch38	473-020	£249.17
XSW72 Instrument - Ch38	473-030	£249.17
XSW52 Headmic Set - Ch38	473-040	£290.83
GAM1 Rack Mount	473-550	£149.00
GAM2 Rack Mount	473-570	£41.60
GAM3 Rack Mount	473-580	£16.50

AKG Perception Wireless

UHF Wireless System

A versatile easy to use system covering all applications.

- 8 hours battery life
- Compatible with all AKG MicroMics
- Instrument, Presenter and Sport Sets come complete with the smallest and lightest bodypack transmitter in its class
- Handheld Vocal Set features High gain before feedback capsule, volume control with proven quality
- Instrument Set comes complete with jack lead
- Presenter Set includes the legendary AKG CK99 lavalier mic with optimum intelligibility
- Sport Set features rugged, C 544 L headworn mic which comes with four moisture shields protecting the transducer from perspiration



Description	Code	Price (Ex VAT)
Vocal Set - Channel 70	469-130	£149.00
Vocal Set - Channel 38	469-135	£149.00
Instrument Set - Channel 70	469-140	£149.00
Instrument Set - Channel 38	469-145	£149.00
Presenter Set - Channel 70	469-150	£182.50
Presenter Set - Channel 38	469-155	£166.00
Sport Set - Channel 70	469-160	£199.00
Sport Set - Channel 38	469-165	£199.00

Keep up to date with all the latest products and current prices on the new look **Studiospares** website!

Check out www.studiospares.com

PRICE

changes

This catalogue was priced on 1st December 2014.

Current prices may be higher...

see our website for up to date prices.

PDF

catalogue

Want this catalogue on your phone or laptop?

The Studiospares catalogue is now available in PDF format.

visit www.studiospares.com/page/pdfcatalogue!

Lectrosonics SRB/SR5BP

Dual-Channel Slot Mount ENG Receivers



Two-channel slot-mount Digital Hybrid Wireless@ diversity receivers.

- Offers two independent channels and fits into the standard video camera slots found on professional cameras
- The two audio channels can feed separate inputs or can be mixed internally to feed a single input.
- SRB5P is equipped with an external audio output for cameras that only have one audio input in the slot
- **NOTE:** Not all cameras have two audio channels enabled in the slot.



Lectrosonics SMB/E01

UHF Belt Pack Transmitter



A single battery belt pack transmitter with a range of more than 30 dB.

- Digital Hybrid Wireless Technology
- Power output: SMB: 50mW
- Membrane switch control panel with LCD display
- 256 synthesized UHF frequencies
- Wide input dynamic range



Lectrosonics HH/E01

Digital Hybrid Wireless@ Handheld Transmitter



An elegant solution for a variety of wireless microphone applications including live performance, broadcast, and AV rental.

- Digital Hybrid Wireless Technology
- Standard thread-on capsules
- Membrane switch and LCD interface
- AA battery power
- Selectable RF power at 25 and 50 mW



Lectrosonics Quadpack

Power/Audio Interface



Designed for portable field production, the Quadpack simplifies the mounting and interconnection of two SR Series compact receivers.

- Accepts two SR Series receivers
- Uses 25-pin Unislot adapter
- Balanced XLR audio outputs
- Balanced T3M audio outputs
- Output jack panels can be reversed
- Powder coated aluminum housing



MICROPHONES
Radio Microphones - UHF Ch38 Only

Channel	UHF Channel 38
Frequency	UK 606-614 MHz
Info	Low Cost UK Frequency licence (PMSE) required
Licensing	For UK Licence, contact JFMG http://www.jfmg.co.uk/pages/licence/licence.htm

Trantec S4.16 RX2
UHF Dual Channel Wireless System

A multifunctional system available in 16 selectable frequencies, which can run up to 8 simultaneous channels.

The S4.16 couples efficiency and simplicity to ensure consistent performance each and every time. The S4.16 Dual Channel permits multiple receivers to conjoin, perfect for schools, churches and audio visual applications. Rack'n'Ready options available 4, 6 and 8 way.



Dual Channel Receiver

A multifunctional receiver available with 16 selectable Channel 38 frequencies (606-614 MHz), which can run up to 8 simultaneous channels. The S4.16RX2-G3W couples efficiency and simplicity to ensure consistent performance each and every time.

Handheld

For powerful vocal performance or general speech applications, the S4.16 HDX is an ergonomically designed mic featuring a high quality Trantec cardioid dynamic capsule suitable for the most demanding of vocal applications.

Beltpack

The beltpack is equally at home in applications as diverse as a quiet church through to a grinding step class or a stadium rock'n'roll gig thanks to its range of matching microphone and cable options.



Description	Code	Price (Ex VAT)	Description	Code	Price (Ex VAT)
S4.16RX2-G3W Receiver	434-890	£249.00	Cube-4W 2 x Dual System	434-940	£1290.83
S4.16RX2-HH Dual Handheld	434-900	£490.83	Cube-6W 3 x Dual System	434-950	£2141.67
S4.16RX2-HL Dual H'held/Lav	434-910	£495.00	Cube-8W 4 x Dual System	434-960	£2625.00
S4.16RX2-LL Dual Lavalier	434-920	£499.17	Rack-4W 2 x Dual System	434-970	£1290.83
S4.16-HDX-G3W Microphone	434-930	£132.50	Rack-4W 4 x Dual System	434-990	£2625.00

Description	Code	Price (Ex VAT)
SRB/E01	207-080	£1575.00
SRB5P/E01	207-090	£1675.00
SMB/E01	207-020	£975.00
HH/E01	207-040	£895.00
Quadpack	207-070	£475.00

For many more accessories in the Lectrosonics range, please see our website for more details.

WANT a job?
Are you looking for a stable and rewarding career?

Studiospares are constantly expanding. We require additional staff for a variety of positions, working in a very congenial atmosphere. Practical experience of recording and/or live sound engineering would be preferable.
send in your CV in the first instance

PAYPAL
online payments

Worried about using your credit card online?
We now accept Paypal for online payment!



visit www.studiospares.com for more information

DELIVERY BEFORE NOON
no problem

SATURDAY DELIVERY
no problem

ALL PRICES EXCLUSIVE OF VAT.

MICROPHONES

Radio Microphones - UHF Ch38 Only

CONTINUED

Trantec S5.3/S5.5

UHF Radio Microphones

Offers a powerful set of features at a price that's hard to match - with the whole system coming rackmounted and ready to use right out of the flight case.

Cube System

Similar to the 4-channel system in the picture, but with the 4 units stacked vertically in a square-format case (not 19" wide).

Racked N Ready Systems

Choose between 4, 6, 8, 10 or 12 receivers, and any combination of 4 to 12 handheld and beltpack transmitters to make up your system. 19" professional flight case included. Antenna distribution, 2x antennae, and power supply included. Codes and prices quoted include the optional Remote Antenna Kit, giving you even higher quality performance.

Handheld

Fully synthesised UHF Transmitters which features Integral LCD, IR data link, Battery status indicator, Audio multistage attenuator, Microphone mute switch.

Lapel x2

High quality miniature lavalier mic suitable for all areas of live work.

Headworn

A high quality headband microphone, extremely small and light, designed to be worn around the head and to be hidden discreetly under the hair.

Please see our website for more details.



Description	Code	Price (Ex VAT)
S5.3 Cube 4 - Channel 38	434-320	£2355.83
S5.3 Racked N Ready 4 - Channel 38	434-190	£2355.83
S5.3 Racked N Ready 6 - Channel 38	434-330	£3516.67
S5.3 Racked N Ready 8 - Channel 38	434-240	£4321.67
S5.3 Racked N Ready 10 - Channel 38	434-340	£5626.67
S5.3 Racked N Ready 12 - Channel 38	434-350	£6431.67
S5.3 Cube 4 (No Remote Kit) - Channel 38	434-650	£2165.83
S5.3 Racked N Ready 4 (No Remote Kit) - Channel 38	434-660	£2165.83
S5.3 Racked N Ready 6 (No Remote Kit) - Channel 38	434-670	£3326.67
S5.3 Racked N Ready 8 (No Remote Kit) - Channel 38	434-680	£4131.67
S5.3 Racked N Ready 10 (No Remote Kit) - Channel 38	434-690	£5436.67
S5.3 Racked N Ready 12 (No Remote Kit) - Channel 38	434-700	£6241.67

Description	Code	Price (Ex VAT)
S5.3 HD Handheld Dynamic System - Channel 38	434-380	£415.83
S5.3 HC Handheld Consenser System - Channel 38	434-390	£465.83
S5.3 Lapel X2 System - Channel 38	434-400	£415.83
S5.3 LH HM-66 Headworn System - Channel 38	434-410	£482.50
S5.3 TP HM-22 Headworn System - Channel 38	434-420	£524.17
S5.3 HDX Handheld Transmitter - Channel 38	434-500	£249.17
S5.3 Beltpack Transmitter No Microphone - Channel 38	434-830	£220.00
HM-22 SJ22-BR HI-Q Headworn Mic	434-530	£119.00
HM-22 TS22-BR HI-Q Headworn Mic	434-540	£136.00
HM-22 X22-BR HI-Q Headworn Mic	434-550	£128.00
Biege Tie Clip for HM-22P and LM-212P	434-230	£5.10
Black Tie Clip for HM-22B and LM-212B	434-231	£5.10

Description	Code	Price (Ex VAT)
S5.5 Cube 4 - Channel 38	434-360	£2995.00
S5.5 Racked N Ready 4 - Channel 38	434-210	£2995.00
S5.5 Racked N Ready 6 - Channel 38	434-141	£4514.17
S5.5 Racked N Ready 8 - Channel 38	434-260	£5651.67
S5.5 Racked N Ready 10 - Channel 38	434-370	£7289.17
S5.5 Racked N Ready 12 - Channel 38	434-270	£8426.67
S5.5 Cube 4 (No Remote Kit) - Channel 38	434-710	£2830.83
S5.5 Racked N Ready 4 (No Remote Kit) - Channel 38	434-720	£2830.00
S5.5 Racked N Ready 6 (No Remote Kit) - Channel 38	434-730	£4324.17
S5.5 Racked N Ready 8 (No Remote Kit) - Channel 38	434-740	£5460.00
S5.5 Racked N Ready 10 (No Remote Kit) - Channel 38	434-750	£7099.00
S5.5 Racked N Ready 12 (No Remote Kit) - Channel 38	434-760	£8235.00

Description	Code	Price (Ex VAT)
S5.5 HD Handheld Dynamic System - Channel 38	434-430	£582.50
S5.5 HC Handheld Consenser System - Channel 38	434-440	£632.50
S5.5 Lapel X2 System - Channel 38	434-450	£582.50
S5.5 LH HM-66 Headworn System - Channel 38	434-460	£649.17
S5.5 TP HM-22 Headworn System - Channel 38	434-470	£690.83
S5.5 Handheld Condenser Transmitter - Channel 38	434-520	£328.30
HM33 Headworn Microphone	434-510	£34.30
HM33-SJ33 Headworn Microphone Black	434-515	£28.67



MICROPHONES

Radio Microphones - UHF Ch70 Only

Channel	UHF Channel 70
Frequency	UK 863-865 MHz
Info	No licence required
Licensing	Free UK; De-regulated

Trantec S4.4

UHF Radio Microphones

The ultimate choice when up to 4 frequencies are required.

Based on the award winning S4000, the new Trantec S4.4 UHF system boasts a multi-function receiver, 4 frequency switchable channels and the latest PLL quartz tuning technology. It can be used license free in the UK on channel 70. The S4.4 system is available in Lapel and Headworn (Code 414-970) versions, which can be switched for use with a musical instrument, plus a Handheld with a dynamic capsule (Code 414-960). The new S4.4 has a host of additional features including LEDs on the receiver showing Power On, AF Peak level, RF Level and Diversity Channel A or B. In addition, the diversity operation receivers have front mounted antennae and variable gain Jack plug output. The beltpack has a locking 3.5mm Jack plug input. The transmitter battery life is in excess of ten hours.



Description	Code	Price (Ex VAT)
Handheld system	414-960	£115.83
Lavalier/Guitar system	414-950	£115.83
Aerobic system	414-970	£216.66
Active system	434-860	£140.70
Handheld Condenser system	434-870	£196.90
Theatre system	434-880	£236.29
Handheld transmitter	414-290	£109.50

Description	Code	Price (Ex VAT)
Beltpack transmitter	414-280	£109.50
Receiver	414-300	£128.00
LP2 Lapel mic + Minijack	414-250	£33.50
Tie clip for Lavalier mic	414-270	£6.10
Guitar lead inc screw Jack	414-260	£14.80
Rackmount Kit (S4.4/S4.16)	414-890	£30.50

Quad UHF Wireless System

Handheld/Neckband/Combo

Suitable for vocal groups, theatres and presentations.

- A wireless system with 4 independent UHF channels
- 4x Handheld Microphones
- Individual or mixed outputs
- Twin front-mounting antenna
- Supplied with 4 colour coded transmitters
- Carrier frequencies Red 863.01, Yellow 863.42, Green 864.30, Blue 864.99MHz
- Range 60m (max)
- Output impedance 2.2kΩ
- S/N ratio >105dB. Image rejection 85dB typical
- Neckband system as above but with 4x Beltpacks and 4x QU4-N neckband sets
- Combo system as above but with 2x Handhelds, 2x Belt packs and 2x QU4-N



Description	Code	Price (Ex VAT)
Handheld	476-490	£249.00
Neckband	476-500	£249.00
Combo	476-510	£249.00

Chord HU6

UHF 6-Way System

A wireless system with 6 independent UHF channels.

- 2U 19" rack-mountable receiver, featuring 6 separate XLR outputs
- Individual or mixed outputs
- Supplied with 6 colour coded transmitters
- Power supply receiver 12-18Vdc 1500mA adaptor (supplied)
- Batteries 12 x AA (included)
- Carrier frequencies Red 863.42, Green 863.10, Blue 863.70, Yellow 865.00, Pink 864.10, Purple 864.65MHz
- Stability 10PPM
- S/N ratio >105dB
- THD <0.5% @ 1kHz
- Image rejection 85dB typical
- Range 50m (max)
- Output impedance 2.2k Ohms
- Output level: Balanced: 0-400mv, unbalanced: 0-200mv



Description	Code	Price (Ex VAT)
Handheld	476-610	£332.50
Neckband	476-620	£332.50
Combo	476-630	£332.50

AKG WMS Series

Wireless Radiomic System

A versatile system operating on Channel 70 providing many operational options.

- 3 preset frequency options, ISM 1 863.100 MHz, ISM 2 864.375 MHz and ISM 3 864.850 MHz
- MINI Vocal Set: 1x SR40 Single, 1x HT40 Handheld, 1x Power supply and 1x AA battery
- MINI Instrument Set: 1x SR40 Single, 1x PT40 Beltpack, 1x Mini XLR-Jack cable, 1x Power supply and 1x AA battery
- MINI Dual Vocal Set: 1x SR40 Dual, 2x HT40 Handheld transmitters and 1x Power supply and 2x AA batteries
- Mini Dual Instrument: 1x SR40 Dual, 2x PT40 Beltpacks, 2x Mini XLR-Jack cable, 1x Power supply and 2x AA batteries
- Mini Dual Mix Vocal/Instrument: 1x SR40 Dual Receiver, 1x HT40 Handheld Transmitter, 1x PT40 Bodypack transmitter, and 1x Power supply and 2x AA batteries
- All systems are Channel 70



Description	Code	Price (Ex VAT)
WMS40 ISM1 Mini Vocal Set	469-240	£70.83
WMS40 ISM2 Mini Vocal Set	469-250	£70.83
WMS40 ISM3 Mini Vocal Set	469-260	£70.83
WMS40 ISM1 Mini Instrument Set	469-270	£65.83
WMS40 ISM2 Mini Instrument Set	469-280	£65.83
WMS40 ISM3 Mini Instrument Set	469-290	£65.83
WMS40 ISM2/3 Mini Dual Instrument	469-300	£132.50
WMS40 ISM2/3 Mini Dual Vocal	469-310	£115.83
WMS40 ISM2/3 Mini Dual Vocal/Inst.	469-320	£132.50
WMS40 Mini Mounting Bracket	469-330	£27.50

MICROPHONES

Radio Microphones - VHF

Samson Stage 5

3-In-1 VHF Radiomic System

NEW



With the Stage 5 Wireless System, you get incredible reception, crystal clear sound in a VHF system priced to bring the freedom of wireless to everyone. This system offers transmitters for every application, including handheld, headset and lavalier microphone styles. It's perfect for guitars too, just plug in with a Samson GC5 guitar cable. A great-sounding and incredibly affordable system, the SR5 VHF receiver offers variable squelch, six-segment LED RF level and audio level metering, front mounted antenna and XLR and 1/4" outputs. The ST5 beltpack features 1/8" mini-jack input for all Stage Series mic transmitters and will operate flawlessly for 10 hours with one 9-Volt battery. Includes battery level meter.

Description	Code	Price (Ex VAT)
Stage 5	308-000	£74.17

DELIVERY BEFORE NOON
no problem

SATURDAY DELIVERY
no problem

MORE PRODUCTS
online

ALL PRICES EXCLUSIVE OF VAT.

MICROPHONES

In Ear Monitoring

Sennheiser EW300 IEM G3 Channel 38

In-Ear Monitoring System

Featuring an adaptive-diversity receiver, that uses the headphone cable as a secondary antenna.

- Software can be managed via ethernet
- 5 band equaliser in the transmitter
- 1680 tunable UHF frequencies.
- Pilot tone squelch and HDX compander
- Scan feature searches for available frequencies



Description	Code	Price (Ex VAT)
EW300 IEM G3 - Channel 38	455-870	£739.00

LD Mei 1000X/100X

In-Ear Monitoring System

An advanced 160 channel UHF in-ear monitoring system in the 838 - 865 MHz frequency band with 160 channels available.

- Switchable mono, stereo and focus modes select the perfect monitoring
- Transmission method broadband FM, stereo
- Adjustable EQ and limiter functions
- Multifunction display on the trans and receiver
- Menu lock function
- Receiver connection type 3.5mm Mini Jack
- 3x sizes of ear cushions
- Includes quality earphones, a 19" rackmount kit and a rugged ABS plastic carrying case
- ME1100 same as ME11000X but some controls are menu driven. No Focus facility or equalisation



Description	Code	Price (Ex VAT)
MEI 1000X	460-300	£207.50
MEI 100X	460-310	£149.99

LD Mei One

In-Ear Monitoring System

An advanced UHF in-ear monitoring system operating at 863.700 MHz frequency band with that single channel. (Chan 70=863-865Mhz).

- Transmitter half rack width. Inc. 2x XLR/Jack inputs, level control, L+R level meter, mono/stereo switch, headphone volume and detachable aerial
- Receiver inc. adjustable volume control, RF receiver LEDs and aerial
- Accessories In Ear phones, 19" rack mounts and a carry case
- MEI ONE 2 same as ONE 1 but operating at 864.100 MHz
- MEI ONE 3 Same as ONE 1 but operating at 864.900 MHz



Description	Code	Price (Ex VAT)
MEI ONE1 863.7MHz	460-321	£95.00
MEI ONE2 864.1MHz	460-322	£95.00
MEI ONE3 864.9MHz	460-323	£95.00

DELIVERY BEFORE NOON
no problem

MICROPHONES

Radiomic Accessories

RF-Explorer/3

Handheld Spectrum Analyser

Real-time monitoring of the frequency range with frequency indication and level indication

- RF spectrum analyser, 15-2,700 MHz
- Auto marker function and manual marker positioning for setting a carrier frequency. Special Wi-Fi analyser with display of 13 WLAN channels
- Mini USB 2.0 interface for connecting to a PC or laptop
- Max hold function for detection of ultra-short RF carrier frequencies



Description	Code	Price (Ex VAT)
RF-Explorer/3	256-850	£249.17
RF-Holder for Explorer/3	256-860	£16.50

Studiospares Trojan Wireless Case

5U Microphone Case

Trojan Case designed specifically for rack mounting radio mic systems.

- Lids are 70mm deep and foam filled to hold mics, leads accessories etc
- Front and back covers include Velcro Straps for mounting wireless radio mic transmitters and accessories
- Catches fully retract to allow for the easy removal of covers and lids
- Rack rails front and back 264mm apart
- Recessed chrome butterfly catches are all industrial grade



Description	Code	Price (Ex VAT)
5U Mic Case	458-710	£99.17

MICROPHONES

Windshields

Studiospares Windshield Foam Large

Windshield

Inexpensive Foam windshields

- Fits all large diaphragm condenser microphones with bodies between 45mm and 60mm diameter
- Hole depth 90mm
- Colour Black



Description	Code	Price (Ex VAT)
Windshield Large	448-590	£9.80

Rode Windshields



WS2

Windshields dedicated to various Rode microphones but equally suitable to any other manufacturer's products.

Description	Code	Price (Ex VAT)
WS2 for NT1A	417-450	£22.49
WS8 for NT5/NT55/NT6	417-990	£17.49

Rode Dead Wombat

Windshield

The DeadWombat windshield is designed for minimising wind noise when recording in high wind conditions using the RODE Blimp.

- Its artificial fur is specially designed so as to minimise wind noise while remaining acoustically transparent



Rode Dead Mouse-Pin

Windshield

The DeadMouse-Pin is a professional grade windshield.

- Designed to minimise wind noise to ensure quality recordings in adverse environments with the RODE PinMic



Rode DeadCat GO

Windcover

A furry wind cover for the VideoMic GO, designed for use in windy environments

- Its artificial fur is specially designed so as to minimise wind noise while remaining acoustically transparent
- Weight 15gm
- Dimensions 180mmH x 70mmW x 70mmD



Description	Code	Price (Ex VAT)
Wombat	497-000	£32.50
Mouse-Pin	497-020	£18.30
DeadCat Go	497-200	£16.66

Rode MINIFUR-HS1

Windshield 3-Pack

An artificial fur windshield designed for us on the HS1 headset microphone in outdoor or high wind conditions.

- Also fits similar headset microphones
- The MINIFUR-HS1 is supplied in a pack of three



Rode MINIFUR-LAV

Windshield 3-Pack

The MINIFUR-LAV is a synthetic fur cover for Lavalier microphones, designed for use in outdoor or high-wind conditions.

- Supplied in a pack of three



Description	Code	Price (Ex VAT)
MINIFUR-HS1 3-Pack	497-350	£19.16
MINIFUR-LAV 3-Pack	497-360	£10.41

DID
you know?

At Studiospares we process all incoming orders within a few minutes

If anything is to be added to an earlier order, it will be processed as a NEW order.

MORE PRODUCTS
online

5 Coloured Windshields



Set of 5 coloured foam windshields.

Effectively reduces pop blast and water vapour when held close to the mouth. Aids quick microphone identification on stage. Colours Red, Green, Blue, Yellow and Black. All dimensions nominal. Dia 40-50mm. Depth 65mm.

Description	Code	Price (Ex VAT)
5 Coloured Windshields	405-880	£9.95

Rode Blimp

Shotgun High Wind Basket

A complete windshield and shock mounting accessory for shotgun microphones up to 325mm in length.

- Includes the Dead Wombat Fur Windshield
- Adjustable dual-hoop suspension design greatly reduces handling noise, while the acoustically transparent dome provides protection against wind noise



Rode Blimp 2

Windshield

Greatly reduces handling noise and provides protection against wind noise.

- 25% lighter than the original Blimp
- Adjustable dual-hoop suspension
- Also accommodates most other shotgun mics up to 325mm
- 3/8" thread attachment
- Dead Wombat windshield, caring brush and tail/patch cable included



Rode Blimp Extension

Windshield Accessory

Add-on component kit for the original RØDE Blimp windshield.

- Allows the use of long shotgun mics, including the RØDE NTG8
- includes a 256mm blimp extension piece, two sets of rigid silicone bands, extra long DeadWombat fur windshield and furry brush
- Only compatible with the original Rode Blimp, not Blimp 2



Rode Universal Blimp Mount

Windshield Accessory

An interchangeable mounting adaptor for the RØDE Blimp windshield shock mounting system.

- Allows for simple and lightweight mounting of the Blimp onto a boom pole, boom stand or any other 3/8" thread mounting device
- Weight 60gmn
- Dimensions 65.00mmH x 95.00mmW x 45.00mmD



Audio Technica AT8137

Windshield

Large studio foam windscreen (black).

- Ideal for: AT4033 Cardioid Condenser Microphone, AT4035SV Condenser Microphone and AT4050 Condenser Microphone



Description	Code	Price (Ex VAT)
AT8137	700-240	£32.50

Monacor Windshields

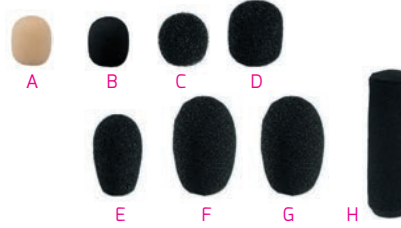

A range of inexpensive Foam windshields drastically reduce and usually eliminate all performer generated pop and blast sounds. Avoids the mic generating high level low and sub sonic frequencies that can overload radiomic transmitters and mixer preamps.

Description	Code
A 4-6mm Skin Coloured. Profile A Fits lavalier mics between 4 to 6 mm diameter. Hole depth 12 mm. Pack of 4.	451-870
B 4-6mm Black. Profile B Fits lavalier mics between 4 to 6 mm diameter. Hole depth 12mm. Pack of 4.	451-880
C 7-9mm Black. Profile C Fits lavalier mics between 7 to 9 mm diameter. Hole depth 15mm diameter	451-890
D 12-14mm Black. Profile D Fits miniature mics between 12 to 14 mm diameter. Hole depth 22 mm.	451-900
E 11-15mm Black Elongated. Profile E Fits miniature mics between 12 to 14 mm diameter. Hole depth 22 mm.	451-910
F 21-26mm Black. Profile F Fits mics between 21 to 26 mm diameter. Hole depth 55 mm.	401-770
G 21-26mm Black Elongated. Profile G Fits mics between 21 to 26 mm diameter. Hole depth 65 mm.	451-920
H 21-26mm Black Shotgun Extra long. Profile H Fits mics between 21 to 26 mm diameter. Hole depth 145 mm.	451-930

Description	Code	Price (Ex VAT)
4-6mm Skin x4	451-870	£7.70
4-6mm Black x4	451-880	£7.70
7-9mm Black x1	451-890	£2.45
12-14mm Black x1	451-900	£2.45
11-15mm Long x1	451-910	£2.55
21-26mm Small x1	401-770	£1.95
21-26mm Long x1	451-920	£2.65
21-26mm Extra Long x1	451-930	£8.80

MICROPHONES

Pop Screens + Acoustics

Studiospares RED 50

Microphone Sound Filter



NEW LOWER PRICE

An entry-level microphone filter offering a significant improvement in clarity when recording vocals.

A simplified design which is quick and easy to set up, the RED50 is also lighter than other alternatives, making it a highly portable solution you can take anywhere. Adjustable both horizontally and vertically, making it simple to get the perfect setup whether you're using a large or small microphone. Comes with a clamp to attach the RED50 to a mic stand. Dimensions 500 x 380 x 260 mm. Also available with a sturdy tripod stand

Description	Code	Price (Ex VAT)
RED 50	465-210	£41.66
RED 50 + Tripod Mic	465-215	£45.83

Studiospares RED 40

Mini Acoustic Diffuser Screen

The RED40 is the latest in our range of recording enhancement devices (REDs). Fitted around a drum mic, it filters and reduces the sound from other drums.

- Record only the sound of the drum you're trying to record
- Reduce unwanted muddiness
- Also works for other instruments
- Highly cost-effective solution



Description	Code	Price (Ex VAT)
RED 40	465-320	£16.50

Economy Pop Filter

Pop Filter

For all standard microphone stands, this pop screen has a double nylon 130mm screen with a sturdy black plastic frame.

- Attaches to stands up to 23mm diameter



Budget Popkiller

Pop Filter

- Adjustable 100mm (4inch) screen
- Spring loaded clip
- Fits most microphone stands

Description	Code	Price (Ex VAT)
Popkiller	415-860	£15.40
Large Popkiller	415-870	£12.90

THE website

Keep up to date with all the latest products and current prices on the Studiospares website!

check out www.studiospares.com

MICROPHONES

Pop Screens + Acoustics

CONTINUED

Studiospares RED 200

Twin Pro Pop Screen

Simply rotate whichever one is the most appropriate or use both together for greater effect.

The dilemma of knowing which type of screen to use for differing conditions is now over. The metal screens slots are polarised to divert the air and break it up. The dual layer fabric screen further dissipates the pop blast such that it cannot distort the sound. The metal grille is more hygienic and can be easily washed and dried to prevent the spread of germs. The gooseneck includes a non marring clamp that will not mark the microphone stand. Sold at a fraction of the price of competitive products.



NEW LOWER PRICE

Description	Code	Price (Ex VAT)
RED 200	465-200	£16.58
RED 200 4-Pack	465-204	£57.50



Studiospares RED 220

Sandwich Pop Filter

Two totally independent stocking type filters provide double protection against popping plosive sounds.

- Detachable head
- Gooseneck length 250mm
- Non marring clamp will not mark the stand if twisted



Description	Code	Price (Ex VAT)
RED 220	465-670	£15.80

Studiospares RED 230

Sandwich Pop Filter

Probably the most effective pop filter of all.

- Front and rear screens are of metal which mechanically protect the fine nylon mesh in the middle
- A high performance product
- Gooseneck length 250mm
- Non marring clamp will not mark the stand if twisted



Description	Code	Price (Ex VAT)
RED 230	465-720	£18.80

Studiospares RED 250

Condenser Pop Filter

An interesting variant on pop screens.

- Surrounds three sides of the microphone making it ideal for groups
- Industrial elasticated bands hold the screen in place allowing both the mic and screen to move in unison
- The acoustically transparent screen is hydrophobic so keeping moisture from reaching the mic
- Fits practically all side address mics with diameters from 1.8" - 2.7" (46mm - 68mm)



Description	Code	Price (Ex VAT)
RED 250	465-730	£19.50

Studiospares RED Mini Booth



The Red Mini Booth is a complete answer to controlling reverb when recording at a desk. Mic stand versions can be unstable through having so much weight aloft. Microphone support system included. Reverb virtually eliminated inside the booth. Acoustically treated doors further protect against reverb bouncing from adjacent walls. Rubber feet and cable access on underside. Includes transportation handle.

Description	Code	Price (Ex VAT)
RED Mini Booth	465-440	£129.00

SE Isolation Pack

Shock Mount and Pop Filter

An essential accessory package for anyone wishing to record vocals and consists of a shock mount and an integrated pop shield.

- The new quick-release shock mount is designed specifically for the Magneto, X1 Series and SE 2200a II series of microphones
- The integrated, height adjustable pop shield with a quick release mechanism for instrument mic'ing is made from metal as oppose to the usual fabric shield
- A cost effective and versatile product



NEW

Description	Code	Price (Ex VAT)
Isolation Pack	422-460	£39.00

SE Project RF-X

Microphone Reflection Filter

With a new lightweight body and re-designed lightweight clamp assembly the RF-X is simplicity itself, providing unbeatable performance and ease-of-use.

- New materials have been developed to make it lighter than its predecessors
- Four layer acoustic filter design comprising the outer composite panel itself, a wool fabric layer, an air gap layer and an inner acoustic foam layer



Description	Code	Price (Ex VAT)
RF-X Reflexion Filter	422-410	£74.17

SE Project Studio

Microphone Reflection Filter

A cost reduced version of their popular Reflexion filter.

- The metal frame is lined with the same patented polyester fibreboard as the Pro version uses for its outer layer.
- A layer of 'crystal' foam with curved undulations is then applied



Description	Code	Price (Ex VAT)
Project Studio	422-370	£107.50

SE Reflexion Filter

Vocalist Microphone Filter

Portable device for recording live sources with reduced room ambience.

It is an advanced composite wall which is positioned behind any microphone by means of a variable position stand clamp assembly which ships with the product. The main function is to help obtain a 'dry' vocal or instrument recording. This is especially useful in studios without proper acoustic treatment, but can also be used to help record takes in control rooms, where the performer also has to operate the recorder, or in rehearsal studios to reduce ambient noise.

Description	Code	Price (Ex VAT)
Reflexion Filter	422-110	£140.83



DELIVERY BEFORE NOON
no problem

DELIVERY BEFORE 10AM
no problem

Studiospares RED 100

Vocalist Microphone Filter

Provides a realistic answer to the problems of unwanted sound entering via the rear of the microphone.

The heart of the answer lies in the construction of the shielding material. Sound isolation rooms use the principle that sound waves agitate a material (the walls) and dissipate that energy into an acoustically absorbant material similar to Rockwool. RED 100 applies that principle by surrounding much of the microphone with a wall. In the case of RED 100 the wall consists of a complex sandwich construction of five differing materials. The results are astonishing providing better detail and a more accurate sound. To save storage space and provide more control over the captured sound the sides can be folded in and out. The RED 100 is intended to be attached to the top of a microphone stand via a standard 5/8" thread. The unit is solid and heavy so the stand must have legs well splayed out otherwise it will fall forward. Round base stands are unlikely to be able to take the weight. The position of the microphone relative to the filter can be varied back and forth.



Studiospares RED 100 Packs

Bundles

The RED 100 is now available in a bundle pack, together with the Rode NT1A condenser microphone or NT2A valve microphone.

Description	Code	Price (Ex VAT)
RED 100	465-160	£82.50
RED 100 + Floor Stand + Thread Adaptor	465-165	£87.50
RED 100 + Rode NT1A	417-007	£185.00
RED 100 + Rode NT2A	417-017	£240.83



"The RED 100 worked out great as it cut out a lot of the ambient sound and gave a clear path for the guide vocal without too much over-spill from the near field monitor mix."

Bernie Shaw
Uriah Heep

Studiospares RED 110

Instrument Microphone Sound Filter

The Studiospares RED 110 is a further development of the RED 100 and intended for instrument microphones. It is an affordable portable solution to improving the sound of the acoustic space surrounding the microphone.

- Microphone protrudes through screen
- Forward/back positioning adjustable
- Mic position held by crocodile clamp
- Multiple layer construction
- Reduces reverb and ambience



Stand NOT included

Description	Code	Price (Ex VAT)
RED 110	465-170	£39.00
RED 110 + Tripod Mic Stand	465-175	£45.00

Studiospares RED 20

Gooseneck Diffuser Screen

A really useful screen which can be mounted to suit many applications.

- Reduces sound waves reaching the mic and reduce sounds being reflected off rear walls
- Gooseneck 330mm long
- Clamps to microphone stand or pole
- Screen 178mmW x 152Hmm x 40mm deep



Description	Code	Price (Ex VAT)
RED 20	465-740	£20.82

Studiospares Stonewall

Dual Blast Filter

Two filters, not the usual one are more likely to break up troublesome breath and blast problems. Not only is the filtering more effective but the large diameter of 150mm is more likely to stop air blasting round the sides. The extra long 350mm gooseneck provides many more mounting options than usual. The stand clamp is NON marring, it won't gouge the stand when twisted!. Imported in bulk and sold direct to user, hence the low price.



Studiospares Metal Mesh Pop Filter

A metal mesh has similar anti blast characteristics as the open cloth counterpart but is more durable and can be easily cleaned with a cloth. Fabric versions are more difficult to clean and sometimes considered unhygienic. The 120mm diameter steel metal screen has a multitude of holes which break up the blast of air emitted by the performer. The remaining metal surrounding the holes are angled to further break up the parallel air currents hitting the screen. Handling is also easier. Imported in bulk and sold direct to user, hence the low price.



Description	Code	Price (Ex VAT)
150mm Stonewall	449-080	£11.30
120mm Metal	449-070	£13.80

K&M Popkiller

Pop Filter

It is not surprising that K&M, Germany's largest microphone stand manufacturer should produce a quality pop filter.

- 120mm diameter screen
- Gooseneck length: 270mm
- Non marring stand clamp.



Large Popkiller

Pop Filter

The large 200mm Popkiller for modern studio engineering.

- Adjustable 200mm nylon screen
- Gooseneck length: 330mm
- Non marring stand clamp.



Description	Code	Price (Ex VAT)
Popkiller	440-240	£19.60
Large Popkiller	428-710	£29.90

Rode WS-HS1

Pop Filters 3-Pack

A high quality pop filter, designed to fit the black HS1-P headset.

- Generally fits all similar headsets
- Should be fitted in the majority of applications to prevent any hard plosive sounds overloading the microphone capsule
- Supplied as a pack of three



Rode WS-LAV

Pop Filters 3-Pack

A high quality pop filter, designed to fit Lavalier microphones.

- Should be fitted in the majority of applications to prevent any hard plosive sounds overloading the microphone capsule
- The WS-LAV is supplied as a pack of three



Description	Code	Price (Ex VAT)
WS-HS1-B Black 3-Pack	497-410	£11.24
WS-HS1-P Pink 3-Pack	497-420	£11.24
WS-LAV 3-Pack	497-430	£9.99

Popper Blocker

Pop Screen

Additional pop filtering which fits inside practically all microphone pop screens.

- Work closer to the mic without it popping.
- Made from an acoustically transparent material so will not affect the sound
- Simply unscrew the ball and insert it over the existing filter
- Fitted in seconds



Description	Code	Price (Ex VAT)
Popper Blocker	403-860	£4.95

MORE PRODUCTS
online

1000s
of products
Available from stock!

MICROPHONES

Pop Screens + Acoustics

CONTINUED

Studiospares RED 203

Triangle Pop Filter

An all metal pop/blast plosive filter.

- Easily washed and highly effective
- Gooseneck length 250mm
- Non marring clamp will not mark the stand if twisted



Studiospares RED 204

Trapezium Pop Filter

An all metal pop/blast plosive filter surrounded by protective rubber edging

- Easily cleaned and highly effective
- Gooseneck length 250mm
- Non marring clamp will not mark the stand if twisted



Studiospares RED 206

Hexagon Pop Filter

An all metal pop/blast plosive filter.

- Easily washed and highly effective
- Gooseneck length 250mm
- Non marring clamp will not mark the stand if twisted



Studiospares RED 207

Gold Metal Mesh Pop Filter

Attractively gold colour adds 'class' to a popular product.

- All metal pop/blast plosive filter
- Easily washed and highly effective
- Gooseneck length 250mm
- Non marring clamp will not mark the stand if twisted



Description	Code	Price (Ex VAT)
RED 203	465-680	£14.40
RED 204	465-690	£16.50
RED 206	465-700	£14.50
RED 207	465-710	£14.50

Studiospares RED 25

Mic Filter Diffuser Pack



Comprises three components. A horizontal bar with a central microphone stand clamp and two 100mm slots for setting the position of the sound diffuser PF42 and the metal pop grille. The sound diffuser dimensions 178mmW x 152mmH x 40mmD effectively absorbs sounds that would normally enter the rear of the microphone. The 135mm diameter metal pop screen breaks up plosive sounds that would otherwise overload the microphone input circuitry. The goosenecks are approx 300mm long. A very convenient method of protecting the microphone from unwanted sounds.

Description	Code	Price (Ex VAT)
RED 25	465-750	£28.50

MICROPHONES

Elastic Suspensions

Rycote Universal Studio Mount

Suspension For Large-Diaphragm Recording Microphones

Remove the weak link from your recording chain!

If you want a quality vocal sound, you need quality components all the way down the line. Rather than let your sound down with a throwaway elastic microphone cradle, get yourself a 21st-century microphone mount.

- Up to 12dB better isolation from cable and stand-borne noise than traditional 'cat's cradle' elasticated microphone mounts.
- Fits any large-diaphragm recording microphone from 18 to 55mm in diameter.
- No elasticated parts - never sags or needs rethreading
- Virtually indestructible

Description	Code	Price (Ex VAT)
USM Mic Shockmount	408-350	£62.49
USM-L Mic Shockmount	408-360	£62.49

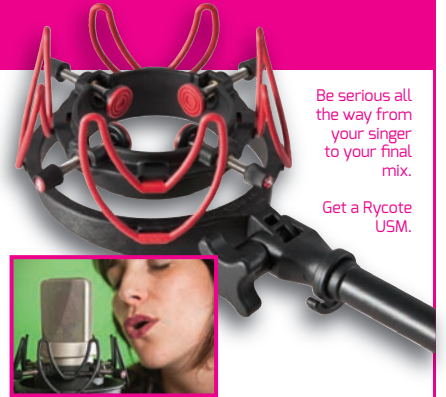

Be serious all the way from your singer to your final mix.

Get a Rycote USM.



AKG H85

22-26mm Shockmount

Universal shock mount for all microphones with shaft diameters from 19 to 26 mm.

- Supports all mics with cylindrical or conical bodies or connectors
- Outside ring diameter 100 mm
- OK for AKG Blue Line and ULS Series
- OK for C 414 series



Description	Code	Price (Ex VAT)
H85	700-891	£42.50

Studiospares Shockmount/Pop Filter

Shockmount

An ingenious way of combining supporting a microphone in a shockmount holder and overcoming the problems of popping when close miking.

- 73mm screen can be easily washed
- Flexible design to suit different mics
- Popfilter is of a metal design
- Designed for mic dia 22mm - 28mm
- Screen to mic distance variable
- Thread size 5/8". For 3/8" mic stands use thread adaptor code 401-100



Description	Code	Price (Ex VAT)
Shockmount/Pop Filter	465-330	£12.46

Studiospares Metal Shockmount

Large Capsule Condenser Mic Shockmount

Combines two applications and removes the problem of attaching the screen to the mic stand.

- For thread sizes M22 x 1
- Pop filter shaft is telescopic
- Dual layer for maximum efficiency
- Screen diameter 134mm
- Thread size 5/8". For 3/8" mic stands use thread adaptor code 401-100



Description	Code	Price (Ex VAT)
Metal Shockmount	465-370	£26.60

Studiospares Economy Shockmount

Double Suspension Shockmount

An effective way to stop sub sonic frequencies reaching the mic.

- Double sprung suspension for maximum rejection of sub sonic frequencies
- Microphone angle variable through 180 degrees
- Really effective against stage borne disturbances
- Can be used with conical shaped mics
- Thread size 5/8". For 3/8" mic stands use adaptor code 401-100



Description	Code	Price (Ex VAT)
Shockmount 22-42mm	465-340	£12.46
Shockmount 22-42mm	465-350	£7.74
Shockmount 22-28mm	465-360	£9.14

Samson SP01

Elastic Suspension Shockmount

An elastic spider mount for Samson C01, C03, CL7, CL8 and C01U condenser mics.

- Fixes to your microphone stand
- Designed to reduce rumble and noise
- Only fits Samson Mics.



Description	Code	Price (Ex VAT)
SP01	388-350	£29.16

Beyer EA19/25

Elastic Suspension

For microphones of 19/25mm diameter.

- Clips inside an MKV11 Mic Holder which is supplied as part of the unit



Description	Code	Price (Ex VAT)
EA19/25	410-460	£33.20
MKV11 Clip	410-450	£17.90

Rode SMR

Shockmount/Pop Filter

A revolutionary shock mount for large diaphragm condenser mics.

- Features a unique double-Lyre suspension system
- Removable pop filter
- Engineering grade reinforced polymer frame
- Efficient cable-management
- Clamping system
- Base nut is also included



Neumann EA4

Shockmount

Elastic Suspension Shockmount from Neumann.

- Swivel mount with a 5/8"-27 female thread
- Features a thread adapter to connect to 1/2"- and 3/8" stands
- Compatible with the Neumann TLM 102 and Sennheiser MK4 microphones



Description	Code	Price (Ex VAT)
EA4 Nickel	416-470	£76.25
EA4 Black	416-475	£76.25

Desk Attached XLR Microphone Holder

A useful means of attaching a microphone or gooseneck firmly to desks, podiums, countertops, walls and ceilings.

- Cable passes out through the bottom of the flange
- Made from a durable cast metal
- Base diameter is 70mm
- Height (including XLR plug) is 53mm



Description	Code	Price (Ex VAT)
XLR Microphone Holder	465-190	£8.24

Studiospares Elastic Suspension

Large Diameter

These elastic suspensions fit practically all large diaphragm condenser microphones. Secure grip by a felt lining. Includes two spare suspension O rings.

- 5/8" 27TPI mic stand thread.
- Black and Silver versions
- Can be angled through 90 degrees
- Rebadged by manufacturers for their own product at double or treble the price. We purchase directly from the factory hence the realistic price



Studiospares Elastic Suspension

Small Diameter

For small diameter pencil microphones with a diameter of between 22mm and 28mm.

- A long sprung collar grips the mic
- Can be angled through 90 degrees
- Colour silver. Non marring.
- 5/8" 27TPI mic stand thread.



Description	Code	Price (Ex VAT)
Large diameter Black	448-670	£19.75
Large diameter Black 4 pack	448-674	£58.25
Large diameter Silver	448-680	£19.75
Small diameter Silver	448-890	£15.30

Rode NT SM2

Suspension

- A suspension suitable for the Rode Classic II, NT1A, NT2A, NT1000, NT2000, K2 and NT-K.



Rode NT SM4

Suspension

- As above but with 3/8" or 5/8" threaded stand adaptor.



Rode NT SM6

Suspension

A high quality suspension shock mount that supports many large diaphragm Rode microphones.

- Provides isolation from external physical factors
- Removes unwanted rumble and vibrations in the microphone.
- Includes a removable pop shield with two axes of adjustment
- Includes telescopic arm for ultimate application versatility



Description	Code	Price (Ex VAT)
NT SM2	417-090	£49.17
NT SM4	417-330	£32.50
NT SM6	417-050	£40.83
NT SM3/4/5 Suspension Bands	703-115	£15.00

MICROPHONES

Goosenecks

Goosenecks

Heavy Duty



BASE UNIT

2 Versions
3/8 inch threaded bolt Base.
Code 409-170

5/8 inch threaded bolt Chrome Base.
Code 401-030



A range of Heavy Duty Goosenecks with a diameter of 15mm. These Satin Chrome Goosenecks are manufactured in Europe to exacting standards. They are produced for major equipment and microphone manufacturers and used in situations where their use is practically continuous.

	Lower End	Length	Upper End	Code
A	3/8in Female thread	400mm	Female XLR	401-020
B	5/8in Male thread	200mm	Female thread	401-000
C	5/8in Male thread	320mm	5/8in Female thread	401-010

Description	Code	Price (Ex VAT)
400mm 3/8in - XLR	401-020	£29.00
320mm 5/8in - 5/8in	401-010	£11.95
3/8 Base	409-170	£8.25
5/8 Base	401-030	£4.37

VISIT
our trade counter
You'll get friendly advice and immediate access to 8000+ product lines!
free parking for 40 cars

MICROPHONES
Microphone Holders

Audio Technica AT8473

Mic Clip Stand Adaptor

Stand adapter for gooseneck mic with 18.9 mm base to a mic stand or mounting flange.

- Complete with 3/8 in to 5/8 in adaptor



Audio Technica AT8471

Isolating Mic Clamp

Dependably maintains positioning while securely holding the mic.

- Provides effective reduction of stand-transmitted noise



Audio Technica AT8665

Drum Mic Clamp

Drum mic mount enabling you to place the mic within mm of the skin.

- Mic position can be varied
- 5/8 inch thread.



Audio Technica AT8418

Instrument Mic Mount

Rubber-grip spring clamp holds mic securely to instrument without marring the finish.

- Flexible boom aids positioning



Audio Technica AT8468

Violin Mic Mount

Permits unobtrusive placement of microphone between the instrument's bridge and tailpiece.

- Hook-and-loop fastener



Description	Code	Price (Ex VAT)
AT8473	447-170	£20.25
AT8471	447-450	£21.26
AT8665	447-470	£7.25
AT8418	447-480	£38.80
AT8468	447-500	£7.66

Multi Microphone Bar



Consists of four self retaining threaded screws passing vertically through a Black metal bar. They are tapped with 3/8" threads and are fitted with 3/8" to 5/8" adaptors.

Description	Code	Price (Ex VAT)
Microphone Bar	448-220	£5.47

MICROPHONES

Microphone Holders

CONTINUED

SA26 Bulldog Clip

Microphone Clip



The two jaws are sprung to exert a sideways holding pressure. Suitable for bodies 13mm - 26mm diameter. The microphone is removed by squeezing the underside of the jaws together. Inserting and removing mic is a two handed operation. Not ideally suitable for conically shaped bodies but frequently used for such. Jaws hinge through any angle. Stand thread 5/8" with a 3/8" adaptor inside.

Description	Code	Price (Ex VAT)
SA26	401-201	£5.70

Studiospares SMH1

Switched Mic Holder

Screws on to the mic stand by a 5/8" thread (or for a stand with a 3/8" thread use a 401-090 thread adaptor).



- The XLR connecting cable plugs into the rear downward facing XLR socket
- This enables microphones to be plugged in to the system without rearranging the connecting cable
- Includes an ON-OFF switch

Description	Code	Price (Ex VAT)
SMH1	449-860	£7.40

Studiospares Angled Stand Adaptor

3/8-5/8 Adaptor

A really useful angled microphone mount.



- The angle can be adjusted through 90 degrees
- The stand thread is 5/8" and the microphone stud thread is 3/8"
- If the microphone holder has a 5/8" thread use Studiospares adaptor 401-100
- If the stand has a 3/8" thread use a Studiospares adaptor also 401-100

Description	Code	Price (Ex VAT)
Angled Stand Adaptor	449-780	£8.30

Rode iClamp

Mic Holder

Designed to provide additional support for iXY stereo mics during high movement usage.



- Heavy-duty clamp
- For use with an iPhone 4 or iPhone 4S

Description	Code	Price (Ex VAT)
iClamp	497-010	£8.32

Microphone Holders



Description	Code
A Rhythm Tech MC2 Wireless Mic Clip Allows mics to be easily released or mounted to a mic stand. Also suitable for wider bodied, standard mics. No thread adaptor included. Diameter 29mm.	401-050
B Beyer MKV 8/11 Manufactured from a rubbery/plastic material the MKV series are quite flexible and provide a good grip on straight or conically shaped bodies. Because the slot between the top of the jaws are wide and the jaws are more flexible mics can be inserted with ease. Popular for stage work. Jaws hinge on the stand holder at any angle. Stand thread 5/8" with a 3/8" adaptor inside.	410-210
MKV8 suitable for diameters 22mm - 32mm.	410-210
MKV11 suitable for diameters 32mm - 42mm.	410-450
C K&M Microphone Clip Tapered slip-in microphone clip with various diameters. Fabricated from an elastic rubber material. 85050-000-55 comes with a 3/8 to 5/8" thread adaptor.	
Microphone Clip 22mm	438-620
Microphone Clip 28mm	438-630
Microphone Clip 34mm	438-640
D AKG SA60/61/63/44 Manufactured from a rubbery/plastic material the SA60/61 mic holders provide a very firm grip on both straight and conical shaped bodies. Requires a degree of force to push the mic downward as the jaws are very strong and the slot between the top of the jaws is small. Jaws hinge on the stand holder at any angle. Stand thread 5/8" with a 3/8" adaptor inside.	
SA60 suitable for diameters 19mm - 27mm.	409-370
SA61 for tapered diameters 21mm- 31mm.	409-380
SA63 for straight diameters 30-39mm.	409-700
SA44 Suitable for tapered diameters 20-25mm.	439-070
E K&M Drum Mic Holder Unique, compact holder to attach microphone to drums. Easy to mount and remove. Rubber inserts absorb noise and shock. No parts to lose. Tightens securely. 3/8" microphone thread. Height 60mm. Colour Black.	428-280
F K&M 85035 New tapered slip-in microphone clip, for microphone diameters up to about 17mm, manufactured from a high quality elastic rubber. OK for 3/8" and 5/8" threads.	478-140
G UB1 Conical Clip For conically shaped vocalist mics. Grip is of pliable rubber. Wide insertion channel aids quick insertion/release but requires a little force if a strong grip is required. Popular for stage work. Stand thread 3/8".	401-990

Description	Code	Price (Ex VAT)
MC2 Clip	401-050	£10.95
MKV8	410-210	£16.65
MKV11	410-450	£17.90
Mic Clip 22mm	438-620	£7.50
Mic Clip 28mm	438-630	£8.60
Mic Clip 34mm	438-640	£9.80
SA60	409-370	£15.80
SA61	409-380	£14.60
SA63	409-700	£17.70
SA44	439-070	£16.37
Drum Mic Holder	428-280	£11.70
85035	478-140	£8.80
UB1	401-990	£8.75

Sabra ST2/ST4

Mic Supports

Consisting of two 3/8" and 5/8" male thread devices and one articulated 3/8" and 5/8" female thread support, all sliding on a 20cm long hexagonal rod.



- Accommodates combinations of shockmounts and pop filter
- Coloured Black

Description	Code	Price (Ex VAT)
ST2 Universal Dual Support	447-510	£37.50
ST4 Universal Quad Support	447-520	£38.21

Rode Stereo Bar

Mic Holder



A robust solution for mounting two microphones in a stereo array.

- Clearly marked spacing of up to 20cm
- Angle and measurement indicators for ORTF and XY positioning
- Makes it quick and easy to achieve complex recording arrays
- 5/8" mounting threads, supplied with spacing clips
- Allow for easy positioning for stacked arrays
- Robust ABS construction

Description	Code	Price (Ex VAT)
Stereo Bar	497-380	£26.66

Studiospares Stereo Mic Bar

Mic Holder

Stereo bar with fixing bolts set 160mm apart.



- All threads are 5/8"
- If using microphone holders with 3/8" threads use Studiospares adaptor 401-090
- If using with a mic stand with a 3/8" thread use a Studiospares adaptor 401-100

Description	Code	Price (Ex VAT)
Stereo Mic Bar	449-770	£8.30

MORE PRODUCTS online

Microphone Holder

A flexible microphone holder based on the Beyer MKV8.

The rubbery material is very pliable and maintains a firm grip on the microphone. Holder assembly hinges through 180 degrees. Accepts straight and conical shaped mics between 20mm and 30mm.

Includes 3/8inch to 5/8inch Thread adaptor.



Description	Code	Price (Ex VAT)
Microphone Holder	403-280	£4.89
Microphone Holder - 10 Pack	403-281	£32.50

Guitar Cabinet Mic Clamp

Firm and secure holding mechanism with a flexible gooseneck allows precise positioning.

- Stand dimensions: 245 mm
- Max extension to 430mm



Description	Code	Price (Ex VAT)
Mic Clamp	460-290	£32.50

Rode Pivot Adaptor

Mic Holder

A durable machined-aluminium, brass and high-grade polymer adaptor for mounting on boom stands and boompoles.

- Allows for up to 210 degrees of pivot.
- A 5/8" to 3/8" adaptor is included.
- Dimensions 70.00mmH x 45.00mmW x 33.00mmD



Description	Code	Price (Ex VAT)
Pivot Adaptor	497-370	£23.33

K&M 85070

Mic Holder

Sturdy and reliable microphone clip.

- Made from an elastic, high quality plastic material
- Holds absolutely securely most popular types of microphone with a shaft diameter of 34 - 40 mm



Description	Code	Price (Ex VAT)
85070	478-870	£14.50

Mic Hygiene

Microphone Spray

Microphone/Headphone Sanitising Spray

Pumped in a measured dose of aerated foam applied with a cloth or hand which clings to the external microphone mesh.

- Antimicrobial cleaning fluid
- Foam does not touch the internal electronics
- Foam dissipates within two minutes
- Effective alcohol free formula and foam aeration system
- No more fear of infection
- 50mL bottle provides approx 100 applications



Microphone Kit

Includes a 50mL spray, soft nylon scouring pad, cleaning brush, micro fibre cleaning cloth and a Black zipper case.

Description	Code	Price (Ex VAT)
Sanitising Spray	635-540	£9.95
Sanitising Kit	635-550	£19.95

Mic Accessories

Rode Invisilav

Skinsafe Mic Mounts

Designed to aid the concealing of the Lavalier and smartLav mics.

- Soft construction absorbs noise and vibration
- Wide, flat profile provides coverage from the elements
- Provides for versatile mounting
- Two mounting points in case a redundant mic is required
- Comes with pre-cut, skinsafe adhesive
- Sticks to either the body or to fabric
- Made from a medical grade skin safe material



Description	Code	Price (Ex VAT)
Invisilav 3-Pack	497-170	£14.99
Invisilav 10-Pack	497-180	£37.49

Rode Violin Clip

Mic Clip

Stringed instrument mount for Lavalier Microphones.

- Designed to easily clamp onto the strings of a violin in the bridge area behind the top plate
- Allows for the precise mounting of a RØDE Lavalier microphone
- Dimensions 20.00mmH x 47.00mmW x 6.00mmD
- Weight 2.00gm



Description	Code	Price (Ex VAT)
Violin Clip	497-400	£9.58

Rode CLIP1

Mic Clip

MiCon Cable Management Clip.

- A cable management clip
- Designed to allow optimal mounting of MiCon cables on the microphone user
- Supplied in a pack of three
- Weight 3.00gm
- Dimensions 8.00mmH x 11.00mmW x 29.00mmD



Description	Code	Price (Ex VAT)
CLIP1	497-330	£14.58

Rode LAV-CLIP

Mic Clip

Microphone Mounting Clip.

- An ergonomic and discreet clip mount for the RØDE Lavalier microphone
- Supplied in a pack of three
- Weight 3.00gm
- Dimensions 24.00mmH x 11.00mmW x 27.00mmD



Description	Code	Price (Ex VAT)
LAV-CLIP	497-340	£15.83

Smartphone Mic Accessories

Rode Grip

iPhone Holder

A multi-purpose mounting solution for the Apple iPhone 5, iPhone 5s, iPhone 5c, iPhone 4 and iPhone 4S.

- A camera-shoe mount with a 3/8" thread in the base
- Can be mounted in three different positions
- Handheld, Boom Stand mounted or Camera mounted audio recording with the i-XY stereo microphone
- Handheld pistol grip filming
- Constructed from durable, high-quality ABS plastics



Rode Grip + iPhone Lens Kit

As above but with three high-quality photographic lenses 2x Telephoto, 180 degree fisheye and wide-macro.

Description	Code	Price (Ex VAT)
Grip	497-130	£26.66
Grip + iPhone Lens Kit	497-140	£58.32

WANT a job?

Are you looking for a stable and rewarding career?

Studiospares are constantly expanding. We require additional staff for a variety of positions, working in a very congenial atmosphere. Practical experience of recording and/or live sound engineering would be preferable.

send in your CV in the first instance

VISIT our trade counter

You'll get friendly advice and immediate access to 8000+ product lines!

MICROPHONES

Smartphone Mic Accessories

CONTINUED

Rode SC2

iPhone-iXY Mini Jack TRS Cable

A high-quality shielded 3.5mm TRS patch cable.

- Extends from 170mm to up to 400mm
- Right-angle connectors for ergonomic use
- Connects the output of an Apple iPhone to other equipment



Description	Code	Price (Ex VAT)
SC2	497-150	£9.16

Rode SC6

Smartphone Dual Smart Lav TRRS Kit

A input/output breakout box for smartphones and tablets.

- Two TRRS inputs and one stereo headphone output
- Connects to any TRRS device
- Can use one or two smartLavs into the one mono channel in interview or dual-dialogue scenarios
- Note that the two mic inputs will be recorded to the same channel



Description	Code	Price (Ex VAT)
SC6	497-160	£10.82

Rode Rodegrip

Multi-Purpose Mount for iPhone

A multi-purpose mounting solution for the Apple iPhone 5, iPhone 5s, iPhone 5c, iPhone 4 and iPhone 4S.

- A camera-shoe mount with a 3/8" thread in the base that can be mounted in three different positions
- Constructed from durable, high-quality ABS plastics
- Folds down into a small, portable form factor for ease of transport
- Weight 60.00gm



Rode Rodegrip+

Multi-Purpose Mount and Lens Kit for iPhone

As above but supplied with three high-quality photographic lenses (2x Telephoto, 180 degree fisheye, wide-macro) that screw into the frame to allow for versatile filmmaking on the iPhone.

Description	Code	Price (Ex VAT)
Rodegrip for iPhone 5/5S	497-210	£26.66
Rodegrip for iPhone 5C	497-230	£26.66
Rodegrip+ for iPhone 5/5S	497-220	£57.50
Rodegrip+ for iPhone 5C	497-240	£57.50

Rode SC3

Smartlav TRRS-TRS Adaptor

A high-quality shielded adaptor.

- Connects the smartLav to 3.5mm TRS devices
- Connects to cameras and audio recorders
- Gold-plated contacts are colour coded
- Grey indicating the TRRS input



Description	Code	Price (Ex VAT)
SC3	497-250	£9.16

Rode SC4

TRRS-TRRS Adaptor

High-quality shielded adaptor cable for microphones with a 3.5mm output to connect to TRRS smartphones and tablets.

- Gold plated contacts are colour coded
- Grey indicating the TRRS output
- Operates with Apple IOS devices such as the iPhone and iPad
- Also compatible with the majority of Android devices



Description	Code	Price (Ex VAT)
SC4	497-260	£9.16

Rode SC7

TRS 3.5mm-TRRS Patch Cable

Designed to allow the VideoMic GO to connect to TRRS compatible devices such as the iPhone or iPad.

- Gold plated contacts are colour coded
- Grey indicates the TRRS output
- Cable is colour matched to the red TRS to TRS cable that is supplied with the VideoMic GO



Description	Code	Price (Ex VAT)
SC7	497-270	£9.16

MicFX Crystal

Mic Sleeve

Stunning and exclusive MicFX Microphone Sleeves.

- Fits Wireless Microphones Only
- A-Grade Crystal Rhinestones
- Firm fit and microphone specific to make and model
- Appearing on a whole host of popular TV shows
- Keeps hands off cold microphone bodies
- Includes Soft Carrying Case



Description	Code	Price (Ex VAT)
White Diamond Sleeve	735-120	£57.50
Ruby Red Sleeve	735-130	£57.50
Gold Sleeve	735-140	£57.50
Pink Sleeve	735-150	£57.50

MicFX Wired

Mic Sleeve

Fits Wireless or Coded Mics.

- Real reflective metal mirrors that grab your stage lights and explode with colors to match any outfit
- Slides on and off to access all L.E.D. & switches for a firm fit
- The second you put this on your microphone you'll feel like a star
- Seen on major TV shows and tours like Glee, Nashville and The Grammys



Description	Code	Price (Ex VAT)
Silver	735-070	£12.49
Gold	735-080	£12.49
White	735-090	£12.49
Red	735-100	£12.49
Pink	735-110	£12.49

MICROPHONES

Phantom Power Supplies

Art Phantom II

12/48 Volt Battery Powered PSU

Powers 1 or 2 condenser mics with DC of 48 volts for polarised large diaphragm microphones or 12 volts for pre charged electret types.

- Powered by 2x 9 volt batteries which are included
- Quiet electronics through good design



Art Phantom I

48 Volt Phantom Power Supply

With XLR female input, XLR male output, 48V DC phantom power, frequency response 10Hz to 25kHz.

- 18 Volt power adaptor included



Description	Code	Price (Ex VAT)
Phantom II	325-140	£39.90
Phantom I	325-330	£29.30

Mic Sleeves

MicFX Hologram

Mic Sleeve

MicFX microphone sleeves will ensure you capture the stage lights with your individual and unique personality.

- Stunning and exclusive MicFX Microphone Sleeves.
- Used and loved by many rock, pop and country stars
- Appearing on a whole host of popular TV shows
- Keeps hands off cold microphone bodies



Description	Code	Price (Ex VAT)
Red Lips Sleeve	735-160	£10.42
Red Flames Sleeve	735-170	£10.42
Silver Flames Sleeve	735-180	£10.42
Gold Flames Sleeve	735-190	£10.42

VISIT

our trade counter

You'll get friendly advice and immediate access to 8000+ product lines!

free parking for 40 cars

SATURDAY DELIVERY
no problem

DELIVERY BEFORE 10AM
no problem

Studiospares 48V Phantom Power Supply Unit

Mains powered 48 volt power supply.

2 Channel Phantom PSU. All metal construction ensures effective screening from unwanted magnetic fields which would cause 50Hz hum. Inputs and outputs are clearly marked. Lifetime guarantee. Manufactured in accordance with Quality standard ISO9001. Single channel version also available.



Description	Code	Price (Ex VAT)
48V Phantom 2	448-550	£28.30
48V Phantom 1 Channel	449-000	£25.50

AKG B29L

Low Voltage Microphone Power Supply

The AKG B29L provides two mic inputs, XLR and mini Jack.

- Provides 1.5 Volts to 3 Volts to power electret microphones
- Both input levels are adjustable
- Belt clip
- Battery life 1000 hours.



Description	Code	Price (Ex VAT)
B29L	409-080	£41.60

Stageline EMA-1

Phantom PS Adapter Mini-XLR To XLR

Dual purpose low voltage battery powered phantom power supply.

- 1.5v battery (not supplied) provides a low voltage to power phantom powered electret microphones which use mini XLR connectors.
- Turned off, it still provides low voltage phantom power if connected to 48v phantom supply from a mixer



Description	Code	Price (Ex VAT)
EMA-1	450-850	£26.50

Phantom Power Adaptor EMA300P

XLR - Mini XLR

Overcomes the problem of connecting low voltage Electret mics which use a Mini XLR to 48v phantom powering via an XLR.

- Microphone end has a Mini XLR connector. Mixer end standard XLR
- It reduces the 48v mixer output to approx 9 volts.



Description	Code	Price (Ex VAT)
EMA300P	255-830	£22.60

Rode VXL

Minijack-XLR Male Adaptor

Interfaces a minijack plug with an XLR input. Can be used in the reverse direction.

- A useful adaptor to include in the toolbox
- XLR plug one end and a minijack socket the other end



Description	Code	Price (Ex VAT)
VXL	417-950	£8.58

Tritonaudio Phantom Blocker

Phantom Power Supply

Prevents the mixers phantom power wrecking ribbon and dynamic microphones

- Audio signal remains unaffected
- Applies in either direction
- Protects a mixer input where the mic is being powered by it's own power supply
- Protects mixers phantom power resistors



Description	Code	Price (Ex VAT)
Phantom Blocker	314-080	£29.80

Thread Adaptors

Thread Adaptors



Description	Code
A STA4 Female diameter 3/8inch Male diameter 5/8inch	401-100
B STA5 Female diameter 5/8inch Male diameter 3/8inch	401-090
C STA6 Female diameter 3/8inch Male diameter 1/2inch	401-140
D STA7 Female diameter 1/2inch Male diameter 3/8inch	401-130

NOTE. The Studiospares version of the STA4 fits both versions of the 7/8 inch 27TPI threaded microphone holders without jamming.

Description	Code	Price (Ex VAT)
STA4	401-100	£3.90
STA4 Black and Lipped version	401-105	£3.90
STA5	401-090	£3.43
STA6	401-140	£3.10
STA7	401-130	£3.10

MICROPHONES

Mic Splitters + Combiners

ART S8 3-Way

3 Way 8-Channel Microphone Splitter



Can be used to split up to 8 balanced low impedance microphone signals into 16 balanced signals (8 pairs).

- Each channel provides one XLR input, one XLR direct output with two additional transformer isolated XLR outputs for a total of 3 balanced outputs from each single microphone input signal.

ART S8 2-Way

2 Way 8-Channel Microphone Splitter



Each channel of the S8 provides one direct output and one transformer isolated output from a single microphone.

- Passes phantom power from main mixer
- Individual switched ground lift and pad on each channel
- Mains powered.

Description	Code	Price (Ex VAT)
S8 3-Way	325-670	£190.83
S8 2-Way	325-480	£179.00

Stageline MC31

3-Way Microphone Combiner

3 inputs/1 output, for connecting 3 microphones to e.g. one microphone input of a mixer.

- OK for mics with phantom power
- Balanced XLR connections.
- Robustball metal construction



Description	Code	Price (Ex VAT)
MC31	255-310	£18.30

Art Prosplit

Microphone Splitter/Transformer Isolated

Provides one direct output and one transformer isolated output from a single microphone.

- The direct output passes phantom power
- Ground Lift switch
- Input attenuator for line level inputs



Description	Code	Price (Ex VAT)
ProSplit	325-690	£32.90

Art Splitcom

Microphone Splitter/Combiner

A convenient little box when you need to split a female XLR input to two XLR male outputs or vice-versa.

- Passive so no batteries.
- Features a quality built in transformer to eliminate impedance mismatches
- Phantom power passes through



Description	Code	Price (Ex VAT)
SplitCOM	325-110	£24.40

DELIVERY BEFORE NOON
no problem

ALL PRICES EXCLUSIVE OF VAT.

MICROPHONES

Mic Splitters + Combiners

CONTINUED

Studiospares RED 506

Microphone Splitter

A proper microphone splitter using a transformer, not resistors.

Superbly engineered from a die cast aluminium extrusion with metal endplates on which the connectors and switches are mounted. A Phase Reverse switch reverses the signal's polarity. The input has a direct output so can be included in any circuit without losing the signal path. The input and two outputs are transformer coupled to provide complete isolation from ground loop problems. Both outputs have Ground Lift switches. No power supply required. Metal XLRs throughout.



Description	Code	Price (Ex VAT)
RED 506	458-250	£25.30

Studiospares RED 504

Microphone Combiner

Phantom powering from the mixer is fed to both mic inputs via individual phantom power on-off switches. Max input level 26dBu @ 1kHz and 15dBu @ 50Hz. Response only 0.15dB down at 20Hz and 20kHz. No power supply required. Ground Lift switch. Superbly engineered from a die cast aluminium extrusion with metal endplates on which the connectors and switches are mounted. Metal XLRs throughout.



Description	Code	Price (Ex VAT)
RED 504	458-230	£25.70



MICROPHONES

Mic/Line Problem Solvers

Stageline LSP102

2-Channel 3-Way Line Splitter

For the connection of e.g. one mixer to several amplifiers.

- 2 inputs, 6 outputs
- Balanced XLR inputs with ground lift
- Balanced outputs



Description	Code	Price (Ex VAT)
LSP102	255-320	£29.60

Stageline LC31

2-Channel 2-Way Line Combiner

2-channel 2-way line combiner, for connecting e.g. 2 mixers to one amplifier. 4 inputs/2 outputs

- 1 balanced XLR direct input for each channel
- 1 balanced XLR output for each channel
- Robust metal housing.
- Dimensions: 160 x 55 x 85mm



Description	Code	Price (Ex VAT)
LC31	255-300	£26.30

Stageline FGA-202 Isolator

2 Channel Line Transformer

Professional 2-channel line transformer, for reducing signal interference and earth loops.

- 2 inputs via balanced combination XLR/1/4" Jacks
- 2 DC separated XLR outputs (600Ω) with groundlift switch
- Frequency range: 20-20,000Hz
- Dimensions: 125x55x75mm
- Weight: 650g



Stageline FGA-102 Isolator

Stereo Line Transformer

For reducing signal interference and hum loops which may occur.

- Ideal when connecting PC sound cards to HiFi systems or mixers
- Gold-plated RCA (phono) connections



Description	Code	Price (Ex VAT)
FGA-202	255-280	£37.20
FGA-102	255-290	£29.70

Studiospares RED 800

8-Channel Microphone Splitter



The Red 800 is based on the finest wide bandwidth audio transformers currently available. Each input is linked to a rear panel direct output and an isolated output.

Problems of hums and buzzes are eliminated by the isolation of the transformers and the provision of individual channel ground lift switches. Line level signals will not overload the circuitry through the inclusion of a -40dB attenuation pad. Front panel switches allow individual channels can be set to provide two balanced outputs by linking the input of a pair of channels. i.e. channel 3 can be linked to channel 4. Makes providing an additional isolated microphone signal a breeze.

Description	Code	Price (Ex VAT)
RED 800	458-950	£107.50



THE website

Keep up to date with all the latest products and current prices on the Studiospares website!

check out www.studiospares.com

VISIT our trade counter

You'll get friendly advice and immediate access to 8000+ product lines!

free parking for 40 cars

PRICE changes

This catalogue was priced on 1st December 2014.

Current prices may be higher...

see our website for up to date prices.

Studiospares RED 502

Bi-directional Balanced/Unbalanced Converter

Single channel Passive Bi-directional Balanced to Unbalanced and vice-versa.

Superbly engineered from a die cast aluminium extrusion with metal endplates on which the connectors and switches are mounted. Input/Outputs are a standard quarter inch Jack socket and an RCA Phono socket. The other end has male and female XLRs as balanced Inputs/Outputs. Inputs to outputs are fully isolated from each other via a transformer. An earth lift switch is provided. Response 0.05dB down at 20Hz and 20kHz. Max input +28dBu. No power supply required. Metal XLRs throughout.



Description	Code	Price (Ex VAT)
RED 502	458-210	£22.80

Studiospares RED 503

Single Channel Passive Line Combiner

The RED 503 combines two balanced (or unbalanced or a mixture of the two) to a single output. All inputs and outputs are fully isolated from each other via a transformer. An earth lift switch is provided. Metal XLRs throughout. Response 0.05dB down at 20Hz and 20kHz Max input +20dBu.



Description	Code	Price (Ex VAT)
RED 503	458-220	£22.80

Studiospares RED 505

Line Splitter

The RED 505 is a professional quality stand alone line splitter. Its applications include live broadcasting and recording, press conferences and on-stage monitoring. The input circuit is line-level and can also be used as an isolation transformer for long audio lines feeding. The transformer isolation in those situations minimises interferences from SCR lighting dimmers, radio transmitters and AC power wiring. The transformer-isolated feeds retain the advantage of common-mode noise rejection inherent in the use of balanced lines. The splitter has three outputs - one is a direct output and two are transformer coupled. Two-way Ground Lift switches are fitted to help combat ground loops. Maximum input level +24dBu @1kHz and +18dBu @50Hz. Insertion loss less than 0.1dB into 50k ohms and less than 1.5dB into 600 ohms. All metal XLRs throughout.



Description	Code	Price (Ex VAT)
RED 505	458-240	£24.20



Studiospares RED 508

Signal Routing Box



A really useful switcher box that can be used two ways. To direct a signal from one source, say a guitar/keyboard to either an amplifier or to the house PA system. In reverse the SW-21 can direct any one of two signals like either a bass or acoustic guitars to one amplifier. The possible combinations are endless. A link switch links both inputs or outputs together so that a guitar can be connected to both an amplifier AND the in house PA system.

Description	Code	Price (Ex VAT)
RED 508	465-770	£20.82

Monacor SLA-35

Stereo Level And Impedance Matching Amp

A versatile and problem solving amplifier that overcomes gain and impedance matching problems when interfacing smartphones, mobile phones, tablet PCs and MP3 players to an amplifier or a mixer.

- Adjustable attenuation down to 1/10 (-20dB) or gain up to 10-fold (+20 dB)
- Impedance switching Hi/Lo
- Phono and 3.5 mm stereo ins and outs
- Excellent S/N ratio and the wide frequency range make it ideal for problem solving



Description	Code	Price (Ex VAT)
SLA-35	256-920	£32.50

DELIVERY BEFORE 10AM
no problem

MICROPHONES

Mic Transformers

Art T8

8-Channel Transformer/Isolator



A high quality passive audio interface that uses 8 transformers to separate input and output signal grounds, thereby isolating two systems and reducing hum and ground-loop noise.

- All inputs and outputs are XLRs, Jacks and Phonos.
- XLRs on the front panel. Jacks Phonos on rear panel

Description	Code	Price (Ex VAT)
T8	325-660	£114.50

MICROPHONES

Inline Attenuators

ProSpares XLR In Line Attenuators



Four precision attenuators for overcoming overloads when interfacing equipment. Lifetime guarantee.

Description	Code	Price (Ex VAT)
Pro 10dB	568-570	£9.90
Pro 20dB	568-580	£9.90
Pro 30dB	568-590	£9.90
Pro 40dB	568-600	£9.90

Passive Level Attenuator

0dB/15dB/20dB

For attenuating excessive signal levels in order to allow sufficient headroom.

- Three steps, 10db/15db/20db
- Phono plug to Phono socket.
- Gold plated
- A well engineered product



Description	Code	Price (Ex VAT)
Passive Level Attenuator	256-880	£16.65

FREE catalogue

Are you reading someone else's catalogue? Why not call us and order your own copy...

it's free!

MORE PRODUCTS online

MICROPHONES

Passive DI Boxes

Stageline DIB-100

Passive DI Box

Looks good and feels good...

The DIB-100 consists of a two part steel box where the lower half is slightly longer than the upper section. This overhang protects the switches and sockets from sudden death under a musician's feet. There are two high impedance inputs of 50kΩ linked together.

The input signal can be from practically any source, even a loudspeaker circuit because the attenuator has 0, -20dB and -40dB attenuation switches. The internal isolation transformer has a 600Ω output via an XLR male connector. Pin one of the XLR output can be disconnected by activating the Ground Lift switch.



Description	Code	Price (Ex VAT)
DIB-100	440-610	£29.90

Palmer PAN01

Passive DI Box

Passive DI box. Jack input with parallel "THRU" output, transformer balanced XLR output. Can handle both line level and speaker level signals

- For with speaker levels switch in the 30dB attenuator
- Max. input level, 54 dBu
- Input impedance:(at) 60 Hz) 60k Ω
- Max. output level:+ 4 dB
- Earth Lift switch



Description	Code	Price (Ex VAT)
PAN01	602-860	£24.99

Palmer PAN04

2-Channel Passive DI Box

Consists of a housing containing the equivalent of two PAN-01s, making it a dual channel passive DI box.

- This stereo configuration makes it ideally suited for use with certain keyboards and devices which have several outputs
- Same spec as PAN 01



Description	Code	Price (Ex VAT)
PAN04	602-890	£49.17

Switchcraft SC702CT

Stereo AV Direct Box

702 Series Stereo A/V Direct Boxes convert the outputs of equipment such as MP3 players, laptops and DJ mixers to balanced, mic level signals.

- Two fully shielded isolation transformers galvanically isolate input and output connections
- Jack, Phono and MiniJack inputs
- -20dB pad avoids overload
- A mono merge switch connects both channels together
- The ground lift switch isolates the earth to avoid ground loops and buzzes



Description	Code	Price (Ex VAT)
SC702CT	403-370	£132.50

Dual Direct Box

Passive DI Box



A dual version of one of our best sellers. A classic design merged with the latest technology.

Diecast extrusions provide great strength and screen capabilities. The input can be switched to any of three sensitivities, Hi impedance instrument, line and speaker inputs. The back panel includes the XLR output and ground lift switches to resolve any hum loops or grounding problems. Cables can be routed under the box which saves tripping. Rubber corner bumpers. Invaluable on stage!

Description	Code	Price (Ex VAT)
Dual Direct Box	449-300	£24.95

Art PDB4

4-Channel Passive DI Box



The PDB4 is a four channel passive direct box that features four quality fully transformer isolated direct boxes in a 1U 19-inch rack mount chassis. Inputs and outputs of each of the four channels are isolated. Transformer isolation helps to eliminate ground loops. A rock solid, roadworthy interface for connecting outputs of electronic musical instruments (or other audio sources) to the balanced inputs of mixer consoles and other balanced audio products

Description	Code	Price (Ex VAT)
PDB4	326-060	£65.83

E.M.O. Passive DI Box

Single and Dual Channel



The EMO range of DI boxes are extensively used in Broadcast and Recording Studios. Of substantial construction and housed in die cast aluminium boxes, they feature double stack transformers for enhanced response and interference suppression. Outputs are fully floating with an earth lift switch to minimise potential hum problems. There are inputs for instrument linked to a direct output, line and speaker. Where appropriate the inputs provide the correct amount of attenuation.

Description	Code	Price (Ex VAT)
Single Channel	402-950	£78.90
Dual Channel	402-650	£139.00

1000s
of products
Available from stock!

SOCIAL networking

You can now be kept up to date of all things new at Studiospares via the following sites:



follow us on all our social media platforms!

DELIVERY BEFORE NOON
no problem

SATURDAY DELIVERY
no problem

Studiospares Dual DI Box

Passive DI Box

Great for use on keyboards and other stereo output instruments.

The dual design avoids using two DI boxes where the outputs may be slightly different. A classic product housed in a die cast aluminium box. High impedance inputs for guitar or any low level signal, Line input for the outputs of keyboards, synths and any other equipment found on stage or in the studio.

The speaker input can handle levels up to 42dB. The Link output is a convenient Direct Out passing the input signal to other equipment. Problem earth loops are resolved by an Earth Lift switch. This product is frequently used for solving any mismatch or earth loop hum problems.



Description	Code	Price (Ex VAT)
Dual Passive DI Box	458-280	£56.60

MTR DI-1

Passive DI Box

Offers a simple solution to interfacing instrument pickups to amplifiers and mixers.

- Matches high impedance outputs to low impedance mic inputs
- Earth Lift switch
- No batteries, passive unit.



Description	Code	Price (Ex VAT)
DI-1	440-990	£41.50

MTR DI-2P

Passive Stereo DI Box

Two-channel passive design, for stereo keyboards or two discrete mono signals and is housed in a tank-proof steel box.

- Sockets and switches safely recessed under the lid
- Two high quality transformers per channel



Description	Code	Price (Ex VAT)
DI-2P	440-690	£66.40

Studiospares Single DI Box

Passive DI Box

A no frills Passive DI Box that is very practical and designed to live under musicians feet!

- Switches are recessed to prevent damage
- Input switched between Instrument and Loudspeaker: Direct Output.
- All connectors are metal not flimsy cheap plastic versions
- Ground Lift switch kills earth/ground loops.
- Decent plastic feet NOT glued on



Description	Code	Price (Ex VAT)
Single DI Box	458-180	£19.90

Art dPDB

Dual Passive DI Box

Features two high-quality direct boxes in one portable enclosure.

- Input Attenuation 0 dB, -20dB, -40dB
- A 50k Ω Instrument Input
- It allows connection of a music source to an instrument amp while simultaneously patching it to a mixer



Behringer Ultra-DI DI400P

Passive DI Box

The DI400P lets you connect instruments or amplifier outputs. It converts any unbalanced signal to a balanced signal and eliminates unwanted noise.

- Direct output for on stage amps
- Ground lift



Description	Code	Price (Ex VAT)
DI400P	380-790	£13.33

Art PDB

Passive DI Box

The PDB Passive is a high-quality single D.I. Box. Specifications as dPDB above.

- Input Attenuation 0 dB, -20dB, -40dB
- A 50k Ω Instrument Input



Description	Code	Price (Ex VAT)
dPDB	325-640	£36.40
PDB	325-650	£25.40

Rack-Mounted DI Box

4-Way



1U 4-way DI box suitable for transmitting signals of musical instruments or their amplifiers to the mixer.

- 3-way attenuation switches, and XLR outputs on the front and rear panels.
- Ground lift individually switchable for each channel.
- 4 separate channels each with 1/4inch Jacks for the feed-through

Description	Code	Price (Ex VAT)
4-Way DI Box	450-840	£64.50

Studiospares DI Box/Preamp

Comprehensive DI Box with Advanced EQ Facilities

A really comprehensive preamp and DI Box. Capable of enhancing any instruments output by frequency shaping and introducing an external FX loop.

- Instrument/Guitar input
- Separate XLR and Jack line outputs
- Bass, Mid and Treble EQ cut and boost
- FX send and return
- PP3 Battery or 9V DC powered
- Notch frequency 100-350Hz adjustable
- Can be powered by 48V Phantom Power from host mixer



Description	Code	Price (Ex VAT)
DI Box/Preamp	458-190	£38.80

MORE PRODUCTS online

VISIT our trade counter
You'll get friendly advice and immediate access to 8000+ product lines!

MICROPHONES

Active DI Boxes

Studiospares Active DI Box

DI Box

An advanced design which resolves all the problems of interfacing guitars, electronic processors and speaker signals to the input of a mixer or amplifier.

Hums, ground loops, lack of bass frequencies and overloads are resolved in a single box. Two inputs via XLR and Jack with a direct output link which is balanced. The XLR output is balanced and floating so as to avoid ground loops. A switch grounds the output if necessary. The input impedance is 250kΩ so will not influence the tonal qualities of a guitar pickup. Despite the high signal levels of loudspeaker feeds, this DI Box has a -20dB switched attenuator, sufficient to avoid overloading the mixer's input. It can be powered by the mixer's 48volt phantom powering causing an LED to light or via the internal PP9 battery (not supplied).

The case is all metal with rubber bumpers on all corners.



Internal PCB

Description	Code	Price (Ex VAT)
Active DI Box	448-290	£20.83
Active DI Box - 4 Pack	448-294	£72.00



Art Dual Z-Direct

Active DI Box

Let you connect instrument, line, or speaker level signals to a mixer or other balanced inputs through high performance audio isolation transformers.



- High impedance single-ended 1/4" inputs
- Attenuator and Ground Lift switches
- Input Thru jacks allow for tapping off of your signal chain
- Bessel filters on the outputs

Description	Code	Price (Ex VAT)
Dual Z-Direct	325-860	£30.82

Art Dual X-Direct

Active DI Box

Provides two independent high quality active interfaces that let you connect instrument, line, or speaker level signals to a mixer or other balanced inputs.



- High impedance 1/4" and XLR inputs on combo jacks
- Extremely wide frequency response
- Handles high signal levels.
- Features input attenuator switches for a wide range of signal levels
- Input Thru jacks allow for tapping off of your signal chain

Description	Code	Price (Ex VAT)
Dual X-Direct	325-850	£41.66

SM Pro D18E

Active 8 Channel DI Box With Line Mixer



The D18E becomes an indispensable tool solving many problems in the audio field today.

- 8 channel DI Box
- Built in 8 Channel line mixer (Volume and Pan control for each channel and master volume) with headphone amp
- Stereo Line Out
- Each input has a link and a Balanced output
- 20dB Pad per channel each with an Earth Lift
- Pan control per channel
- Internal mains power supply. Metal housing

Description	Code	Price (Ex VAT)
D18E	303-180	£124.99

SM Pro Q-DI

4 Channel DI Box With Line Mixer



A really useful combination of four DI Boxes with a versatile mixer in one package.

- Each input channel has Level, Pan, Ground Lift, Attenuator, Jack input on the front panel
- Rear panel has XLR out for each channel plus an AUX L and R Output on phons
- Attenuators are 0dB, -20dB and -40dB

Description	Code	Price (Ex VAT)
Q-DI	303-220	£74.17

Art Dual RDB

Reamping Direct Box

The Dual RDB is the ideal interface where stereo or dual line level signals from recording interfaces need to be connected to XLR microphone or 1/4-inch instrument level inputs.



- Variable Level Controls with Mute
- Channel Two output phase switch
- XLR and Jack inputs and outputs
- Channel 2 can be linked to chan 1 input
- Balanced outputs. OK unbalanced

Description	Code	Price (Ex VAT)
Dual RDB	325-980	£64.99

THE website

Keep up to date with all the latest products and current prices on the Studiospares website!

check out www.studiospares.com

MORE PRODUCTS online

BSS AR133

DI Box

A genuine 'Studio Standard' DI Box that is curved to allow cables to pass underneath.

The revised AR-133 is improved in mainly ergonomic ways and by having the phantom power supply already built in. The metal box is curved so cables can now pass underneath and the sides are protected by thick rubber heads. For greater protection the switches and sockets are now mounted either end. One end has the input of an unbalanced Jack paralleled to an XLR input and a three position attenuation switch, 0dB, 20dB and 40dB. The other end has the transformer balanced XLR output, an Earth lift switch, power on LED and power on switch. The box can be configured to bypass this switch when phantom powered. The PP3 battery compartment is accessed by unscrewing a knurled screw.



Description	Code	Price (Ex VAT)
AR133	431-310	£89.70

Behringer Ultra-DI 100

Active DI Box



An active design drawing power either from an internal 9 volt battery or via phantom powering. Response 10Hz - 50kHz. Input fully isolated with a transformer. Very quiet front end preamplifier includes gold plated XLRs and Jacks for inputs and outputs. A 50dB switched input attenuator allows connection directly to instruments, line level signals or speakers. An Earth lift switch provides isolation against hum loops. Corners are protected by rubber bumpers which also allow multiple units to be stacked vertically and they give protection against the ground loop that would occur when adjacent DI boxes touch.

Description	Code	Price (Ex VAT)
Ultra-DI 100	370-000	£23.33

Behringer Ultra-DI DI20

DI/Splitter

Consists of two DI Boxes which can be used separately for two different instruments. Link 'On' converts it to a single DI Box with two isolated outputs.

- 9V battery or 48V phantom power
- Ground lift switch
- Input attenuation of up to +48 dBu



Behringer Ultra-DI Pro DI4000

4 Channel Active DI Box



Professional and multi-purpose 4-channel DI box for stage and studio applications.

- Switchable High-cut filter (8 kHz) for guitar applications
- Accurate eight-segment LED level meter for optimum performance
- Direct connection to speaker outputs with up to 3,000 Watt

Description	Code	Price (Ex VAT)
DI4000	370-040	£55.00

FOR fax orders
Use our fax number...
020 8450 4390

Samson S Direct

DI Box

An active DI box that will run off a nine volt battery or 48V phantom power.

- 48 Volt phantom power or 9 volt operation with auto battery shut off
- Earth Lift and Jack link output.



Samson S Direct Plus

Essentially a stereo S Direct, the S Direct Plus is ideal for biamped mono instruments (guitars and bass guitars) or stereo instruments (keyboards).

*Please note that the S Direct does not provide a dummy load for output stages and must be used in conjunction with a speaker cabinet when attenuating from a power stage. (Connect the speaker to the DI Box before anything else).

Description	Code	Price (Ex VAT)
S Direct	368-810	£24.99
S Direct Plus	368-890	£35.82

Behringer Ultra-DI Pro DI800

8 Channel Active DI Box



A professional mains/phantom powered 8-channel DI-box.

The ULTRA-DI PRO DI800 converts unbalanced line inputs into balanced outputs, featuring optional mains or phantom powered operation. Its servo balanced operation assures ultra-flat frequency response. Additionally, it allows direct connection to speaker outputs with up to 3,000 Watts. A ground lift switch as well as input attenuation/gain per channel round off this powerful device.

Description	Code	Price (Ex VAT)
DI800	370-310	£69.50



WANT a job?

Are you looking for a stable and rewarding career?

Studiospares are constantly expanding. We require additional staff for a variety of positions, working in a very congenial atmosphere. Practical experience of recording and/or live sound engineering would be preferable.

send in your CV in the first instance

PRICE changes

This catalogue was priced on 1st December 2014.

Current prices may be higher...

see our website for up to date prices.

PDF catalogue

Want this catalogue on your phone or laptop?

The Studiospares catalogue is now available in PDF format.

visit www.studiospares.com/page/pdfcatalogue!

INDEX

Headphones + Speakers	
Headsets	140
Special Headphones	140
Headphones	141
Earphones	149
Headphone Amplifiers	149
Headphone Splitters	152
Headphone Accessories	152
Ear Protection	153
Studio Monitors	153
Sub-Bass Woofers	161
Studio Monitor Accessories	162
PA Speakers	163
PA Speaker Accessories	171
Installation Speakers	173
Portable PA Systems	176
Induction Loops	177

HEADPHONES

Special Headphones

Hills Indestructible Headphones

Stereo Headphones

Very robust headphones with a braided cable to add to the overall strength of the product.

Braided cable prevents damage in tough usage situations. Ideal for schools, youth clubs etc. Adjustable head band ideal for smaller users. Frequency response: 20Hz-20kHz. Cable length 2.2m, termination (TRS) Molded 3.5 mm (1/8") Stereo Mini-Jack.



Educational 2-Pupil Pack

This educational pack contains two pairs of Hills Indestructible headphones and a headphone splitter, enabling two pupils to listen simultaneously.

Educational 8-Pupil Pack

This educational pack contains 8 pairs of Hills Indestructible headphones and an 8 way stereo splitter, enabling eight pupils to listen simultaneously.

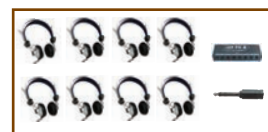

Description	Code	Price (Ex VAT)
Headphones	403-110	£7.90
Headphones x10	403-111	£65.40
Educational 2-Pupil Pack	403-115	£16.50
Educational 8-Pupil Pack	403-118	£99.00

HEADPHONES

Headsets

Beyer DT108/DT109

Headsets

The Beyer DT109 is one of the most popular headsets currently available.

- Noise-cancelling capsule optimised for maximum intelligibility.
- Headphones are the DT100 design offering effective and trouble free operation
- All parts are field serviceable.
- Mic impedance 200 ohms, headphone impedance 400 ohms.
- DT108 is the single earpiece version.
- Please note cables for this headset are sold separately and not included.



Description	Code	Price (Ex VAT)
DT108 Single Earpiece - Black	410-850	£116.65
DT108 Single Earpiece - Grey	410-852	£116.65
DT109 Two Earpieces - Grey	410-770	£125.00
DT109 Two Earpieces - Black	410-772	£125.00
DT109 Two Earpieces 50Ω	410-775	£125.00
Bare Ends Cable 1.5m	430-460	£22.96
Bare Ends Cable 3m	430-470	£26.80
XLR/Jack Cable 1.5m	430-480	£44.50
2 x MiniJack Cable 3m	430-490	£44.50

Hills Indestructible Headset

Stereo Headset

Ultra durable designed multimedia headphones with boom arm microphone for clear speech and high performance.

Robust headset, ideal for Schools, Youth Clubs and Internet cafes. Double steel headband, tensioned to retain shape. 40mm neodymium magnet moving coil speaker. Short Microphone moulded in one piece to the earphone to eliminate damage. Cable length 2m approx.



Description	Code	Price (Ex VAT)
Headset	403-120	£7.90
Headset x10	403-121	£65.40
Headset Spare Bag x1	403-127	£1.99
Headset Spare Bags x10	403-128	£14.99
Headset Spare Earpads 5 Pairs/10 Pads	403-129	£3.75

Hills Mono/Stereo Headphones

Educational Headphones

Electrodynamic headphones with an adjustable headband, cushioned earpads and stereo/mono switch.

- Frequency response: 20-18,000Hz
- Impedance: 32ohms
- Sensitivity: 105dB.
- 3.5mm stereo jack plug with 6.3mm adaptor
- Coiled cable 2.5m (extended) approx



Description	Code	Price (Ex VAT)
Mono/Stereo Headphones	403-160	£11.50
Mono/Stereo Headphones x5	403-161	£49.50

Hills Deluxe Mono/Stereo Headphones

Educational Headphones

Stereo headphones which feature a separate volume/balance control for each ear and a stereo/mono switch.

- Frequency response: 20-18,000Hz
- Impedance: 32ohms
- Sensitivity: 105dB.
- 3.5mm stereo jack plug with 6.3mm adaptor
- Coiled cable 2.5m (extended) approx



Description	Code	Price (Ex VAT)
Deluxe Mono/Stereo	403-165	£14.16
Deluxe Mono/Stereo x5	403-166	£57.50

PRICE changes

This catalogue was priced on 1st December 2014.

Current prices may be higher...

see our website for up to date prices.

SATURDAY DELIVERY no problem

DELIVERY BEFORE 10AM no problem

Telefunken THP-29

Closed Back Extreme Isolation Headphones



Designed for use in both the studio and live sound environments

- Ultra-fidelity, high input 40mm speaker drivers
- Red is Right™ E-Z Channel Identification
- IncrediFlex™ Padded Adjustable Headband
- Foldable for Storage
- Convenient Storage Pouch
- Jack Adapter Keeper
- Eco-Friendly Natural Passive Isolation – No Batteries Required
- Passive Attenuation: 35.7 dB at 8,000 Hz, NRR 29 dB
- Frequency Response: 20-20,000Hz



Description	Code	Price (Ex VAT)
THP-29	499-410	£140.00

Maxell Kids Safe Headphones

Kids Headphones

Small in size (just right for small heads) and have a volume level protection feature that allows you to protect your child's hearing.

- Designed for children
- Limits the sound level to just 90dB
- Soft cushion ear pads are lightweight for a comfortable fit
- Colours Pink and Blue
- Cable length 1.2m Plug 3.5mm Mini Jack
- Hi-Fi frequency response 14Hz - 20kHz
- Impedance 32Ω



Description	Code	Price (Ex VAT)
Blue x1	403-130	£6.25
Blue x10	403-131	£46.66
Blue x20	403-132	£82.50
Pink/Blue 20-Pack	403-139	£82.50
Pink x1	403-140	£6.25
Pink x10	403-141	£46.66
Pink x20	403-142	£82.50

Alesis DRP100

Extreme Drum Headphones

Professional Monitoring for the Electronic Drummer.

- Purpose-built and expertly voiced
- Over-ear design provides extreme isolation and comfort
- Sweat-proof silicone headband
- Rugged, lightweight design
- Frequency Response: 10Hz – 30kHz
- Impedance: 32 ohms
- Max SPL: 98 dB
- Powerful 40mm full-range drivers provide wide frequency response
- 6-foot (1.8m) attached cable with 1/8" (3.5mm) stereo mini-plug
- 1/4" (6.3mm) headphone plug adaptor included



Description	Code	Price (Ex VAT)
DRP100	395-120	£33.32

CAN NC100

Noise Cancelling Headphones

The CAN NC100 noise cancelling headphones are the ultimate in comfort in more ways than one.

They're padded for long-term listening pleasure, while the ingenious electronic circuitry creates a form of destructive interference that literally cancels out surrounding noise. Which leaves you in peace to enjoy your music, without being disturbed by the people around, or the noise of the train, the plane, the car engine, etc. Features 40mm neodymium driver units that provide clear, accurate sound, whether it's a piano concerto or death metal. The headphone's frequency range is 20Hz to 20kHz, while the active noise reduction works on the critical 40Hz to 1kHz range.

Description	Code	Price (Ex VAT)
NC100	288-020	£20.41
NC100 - 3 Pack	288-021	£50.00



Extreme Isolation EX-29B

Headphones



Swiss made products tend to be well made and maintain their specification for years. The EX-29B phones are well thought-out. For travel, they fold up neatly and into a small package. The sound is solid and tight. Nothing hyped – just sonically pleasurable and smooth. The imagery and spatial depth are superb. Extreme Isolation Headphones are quite comfortable considering the extreme design needed to deliver an impressive reduction of 29dB. This version now includes a cable mounted volume control. Impedance 32Ω.

Description	Code	Price (Ex VAT)
EX-29B Black	401-500	£90.83
EX-29W White	401-501	£92.50

Extreme Isolation HP-25

Headphones

A speakerless model that offers you hearing protection with a closed-back isolation chamber.

- Ideal hearing protection for practising music
- Applications include music practice, noise blockage, concentration in office cubicles, and school study in your own quiet space
- Sound attenuation average: 25dB



Extreme Isolation EX-25

Headphones

Direct Sound headphones that are an excellent choice for project studios, personal audio and travel.

- Dynamic closed-back speakers
- Closed back isolation chamber for extreme isolation
- For use by sound engineers, stage and studio musicians, stadium event staff, NASCAR / F1 racing crew



Description	Code	Price (Ex VAT)
HP-25	401-850	£40.83
EX-25	401-840	£74.17

HEADPHONES

Headphones

Audio Technica ATH M Series

Headphones

Designed primarily for studio tracking and mixing, they offer added features for increased portability.

- Advanced build quality and engineering
- 40mm drivers with rare earth magnets and copper-clad aluminum wire voice coils (M50x - 45mm)
- Circumaural design
- Tuned flat for incredibly accurate sound monitoring
- Professional-grade earpad and headband
- 90° swiveling earcups for easy, one-ear monitoring



Description	Code	Price (Ex VAT)
ATH M20x	447-910	£35.83
ATH M30x	447-920	£51.00
ATH M40x	447-930	£74.17
ATH M50x	447-940	£104.17

Audio Technica ATH-PRO 700 MKII

Headphones

The circumaural design achieves remarkable isolation from ambient noise, making them perfect for immersive listening in loud environments.

- 500/900 Swiveling earpieces fold into compact carrying position
- 53mm drivers & 3,500mW of power handling
- Powerful Neodymium magnets
- Impedance 38Ω
- Includes two screw in detachable cords one coiled and one straight
- Comfortable headband makes using the Pro 700 OK for extended listening periods



Description	Code	Price (Ex VAT)
ATH-PRO 700 MkII	447-800	£149.17

1000s
of products
Available from stock!

MORE PRODUCTS
online

HEADPHONES

Headphones

CONTINUED

Beyer DT100

Stereo Headphones

The best selling Studio Headphones in history!

Description	Code	Price (Ex VAT)
DT100 Grey 400Ω	410-001	£103.33
DT100 Grey 400Ω x3	410-003	£290.83
DT100 Black 400Ω	410-005	£103.33
DT100 Grey 16Ω	410-041	£103.33
DT100 Black 16Ω	410-045	£103.33
DT102 16Ω 1-Sided	410-351	£68.85
DT102 400Ω 1-Sided	410-361	£68.85
Ear Pads (Includes Foam Inserts)	410-010	£13.90
Ear Pads Plush Black	410-540	£14.80
Ear Pads Cotton Jersey Black	410-550	£14.80
Foam Inserts each	410-061	£1.78
Headband Pad	410-090	£8.95
Headband End Stop	480-130	£0.25
Headband Cable	480-140	£5.83
K100.7 Straight	410-020	£22.20
WK100.7 Curly	410-161	£26.40
Insert 400Ω	410-051	£25.75
6 Pin Plug	410-071	£8.15
Screw Plg Retainer	410-081	£1.28



The DT100 gained their enviable reputation through their sound quality and solid construction. They are fully modular and we stock all component parts. The new soft foam ear pads provide an excellent seal against feedback. Designed for extended use. Plug-in headphone lead.

BEST SELLER

beyerdynamic)))

Enclosed Design

Beyer DT150

Headphones



The Beyer DT150 includes all the desirable features that have made the DT100 famous plus a revised drive unit which provides an extended and more linear response from 5Hz - 30kHz. Existing DT100s cannot be retro fitted with the DT150 drivers through differing size. Impedance 250Ω.

Description	Code	Price (Ex VAT)
DT150	410-630	£110.83
DT150 3-Pack	410-633	£307.50
DT150 Insert	410-990	£37.40
Earpads Pair	410-530	£20.80

Beyer DT770 Pro

Headphones

Long been accepted as one of the finest all round headphones ever produced.

Simple things like a sprung steel headband, not plastic, and a soft cloth cover to the headphone seal/cups. This closed design yields an isolation figure of 16dB (A). The enclosed design also provides a high degree of low frequency efficiency right down to 5Hz. The upper end extends to 35kHz which demonstrates their smooth response in the audio frequency band. For added convenience the cable is single sided. Impedance 250Ω.

Description	Code	Price (Ex VAT)
DT770 Pro 250Ω	410-830	£110.83
DT770 Pro - 3 Pack	410-833	£312.50
DT770 Pro 80Ω Version	746-150	£110.83

3 PACK



beyerdynamic)))

DELIVERY BEFORE NOON
no problem

MORE PRODUCTS
online

DELIVERY BEFORE 10AM
no problem

SATURDAY DELIVERY
no problem

Studiospares Studio

Open Studio Headphones

Our most popular open-design headphones!

These dynamic headphones provide users with a quality product at a fraction of the price of competitive products. The soft earpads give a high degree of comfort over extended listening periods. The open design removes all traces of "boom" in the sound. The drivers are based on 50mm diameter coils which through their generous dimensions enable the magnetic field to encompass a greater area of drive. This is confirmed by the fact that they can handle 100mW of power!! The Mylar diaphragms are feather light so react rapidly to transients and low frequencies alike. The frequency response extends from 20Hz to 20kHz. The headband is soft padded and fully adjustable. Impedance 32Ω. These headphones are sold at a fraction of their normal price because we import them in the container load. They equal products sold at six times the price. Supplied complete with a Gold plated 3.5mm to 1/4" Jack adaptor. Manufactured in accordance with Quality standard ISO9001. 3m cable. Volume control.

Description	Code	Price (Ex VAT)
Studio HP	448-700	£14.99
Studio HP - 10 Pack	448-701	£124.17

10
PACK



STUDIOSPARES

Beyer DT131

Headphones

The Beyer DT131 have a lightweight design and can be worn indefinitely without fatigue.

- Open design earpieces for clean sound
- Soft, highly pliable and floating headband
- Soft, replaceable earpads
- Frequency range: 20Hz to 18kHz
- Impedance 40Ω so they will work with any 8Ω output
- Lead terminated with a Mini Jack+adaptor
- Available with volume control option, which includes a small control panel with volume control and Mono/Stereo switch



Description	Code	Price (Ex VAT)
DT131	410-381	£29.70
DT131 with Volume Control	410-660	£34.00

Beyer DT250

Headphones

Combines the durability of the long established DT100 with the performance of current HiFi headphones.

- Combines the durability of the DT100 with the performance of current HiFi headphones
- High frequency response, 10Hz-30kHz
- Impedance 80 Ohms
- Detachable curly connecting cable



Description	Code	Price (Ex VAT)
DT250	410-220	£114.53
DT250 250Ω	410-300	£114.53
Spare Inserts	410-670	£24.50
Replacement Lead with plug	711-144	£22.50

Beyer DT231 Pro

Headphones

Provides good sound isolation in high background noise situations at a modest price.

- Closed design headphones
- Lightweight, low profile design
- Frequency range is 20Hz - 18kHz
- Supraaural ear coupling and earpads to maintain long term comfort
- Impedance is 32 ohms and nominal SPL is 95dB.
- Mini-jack plug with 1/4inch adaptor
- Straight connecting cable



Description	Code	Price (Ex VAT)
DT231	410-860	£27.22

Beyer Tesla T90

Headphones

Open design headphones of this kind bring across the feeling of closeness and transparency - nothing stands between sound enthusiasts and their music.

- Velvet materials used on the headband and ear pads ensure endless listening pleasure and long term comfort
- Response 5Hz - 40kHz
- Impedance 250Ω
- Tesla technology providing the highest level of efficiency



Description	Code	Price (Ex VAT)
Tesla 90	480-120	£416.66

Studiospares Presence

Studio Monitor Headphones

The Presence monitor diaphragms are derived from a computer CAD programme which equalises stresses.

- Semi open back design
- Frequency range 20Hz to 20kHz
- 80mW power rating
- 108db sensitivity
- 32Ω impedance
- Jack or Mini Jack compatibility
- Cable length 4m



Description	Code	Price (Ex VAT)
Presence	448-710	£18.17
Presence - 10 Pack	448-711	£157.50

Studiospares Light

Lightweight Stereo Headphones

Great starter pair of headphones, offering a level of clarity and power not normally found at this very affordable price point.



Swivelling and foldable design. High output neodymium magnet drivers. Soft sponge earpads for comfortable use. Frequency response 20Hz to 20kHz. Cable length 1.2m

Description	Code	Price (Ex VAT)
Light	448-770	£7.30
Light - 10 Pack	448-771	£64.00

PDF
catalogue

Want this catalogue on your phone or laptop?

The Studiospares catalogue is now available in PDF format.

visit www.studiospares.com/page/pdfcatalogue/

DELIVERY BEFORE NOON
no problem

ALL PRICES EXCLUSIVE OF VAT.

MORE PRODUCTS
online

HEADPHONES

Headphones

CONTINUED

Studiospares M1000

Closed Type Monitor Headphones

The latest addition to the Studiospares headphone range comes in at the flagship end, offering exceptionally accurate acoustic performance with a natural sound that's designed for studio monitoring and mixing.

A fantastic alternative to expensive branded studio headphones costing 2, 3 or even 4 times as much, the M1000 Monitor headphones enable critical listening for long studio sessions. Featuring a breathable protein leather earpad design for long-term comfort, detachable cable with screw-tight plugs, and 42mm neodymium driver units, the M1000s will not let you down no matter what your style of music. Impedance 64 ohms, frequency response 10Hz to 26kHz. Includes a spare pair of earpads and a 3.5mm to 6.3mm adaptor.

Description	Code	Price (Ex VAT)
M1000	448-760	£54.16
M1000 - 5 Pack	448-761	£243.00
M1000/M2000 Lead	448-765	£3.90
M1000 Earcup/Driver Unit	448-766	£19.50
M1000/M2000 Earpads	448-767	£7.80

5
PACK

STUDIOSPARES



Studiospares M2000

Open-Backed Mixing/Mastering Headphones

Our new professional grade mastering headphones featuring an open-back design for improved accuracy and detail.

This design makes them well suited for mixing and mastering applications, where closed-back designs might restrict the accuracy of the response. Breathable protein leather ear pads designed for long-term comfort. Detachable cable with screwtight plugs. 42mm neodymium driver units. Open-back design for highly accurate sound.

Frequency response 10Hz to 26kHz. Impedance 64 ohms. Designed for professional mixing and mastering. Includes high quality 3.1 meter detachable screw-in cable, 3.5mm to 6.3mm (MiniJack to StereoJack) adapter, 2 x Spare ear pads, instruction booklet and soft carry case.

Description	Code	Price (Ex VAT)
M2000	448-780	£58.29
M1000 - 5 Pack	448-781	£262.00
M1000/M2000 Lead	448-765	£3.90
M1000/M2000 Earpads	448-767	£7.80

5
PACK

STUDIOSPARES



DELIVERY BEFORE 10AM
no problem

MORE PRODUCTS
online

VISIT
our trade counter

You'll get friendly advice and immediate access
to 8000+ product lines!

1000s
of products
Available from stock!

Studiospares Accent

Headphones

Closed-back headphones at a budget price!

Many situations demand good isolation between what goes on inside the headphone and what goes on outside. It's pointless performing in front of a microphone if it can also pick up the sound from your headphones. The Accent headphones have sealed drivers which virtually cut out sounds leaving or entering the earphone. Also, low frequencies do not cancel out so the low frequency performance is better. Their design is very similar to the Presence Studio Monitor. The sensitivity is 108dB and the impedance is 32Ω. 4m connecting lead. Mini Jack to quarter inch Jack adaptor included.

Description	Code	Price (Ex VAT)
Accent	448-740	£16.63
Accent - 10 Pack	448-741	£149.17



Sennheiser HD280 Pro

Headphones

Produces a sound that cheaper models cannot achieve.

- Circumaural robust folding/rotating ear pieces
- Frequency Response 8Hz to 25kHz
- Neodymium magnets coupled to a feather light diaphragm
- Maximum SPL 102dB, impedance 64Ω
- Attenuation to external sounds 32dB



Sennheiser HD203

Headphones

A great-sounding (and surprisingly affordable) set of closed-back headphones.

- Closed, semi-around-the-ear dynamic headphones
- Excellent attenuation of ambient noise
- Extremely comfortable to wear for extended tracking or monitoring sessions
- Replaceable leatherette ear pads
- Innovative headband design
- 3m cable



Description	Code	Price (Ex VAT)
HD203	455-090	£27.49

Sennheiser HD6 MIX

DJ Headphones

Developed with studio-based music creation in mind.

- Constructed of rugged but lightweight parts
- Soft and durable ear cushions
- Proprietary acoustics system gives you an accurate and balanced sound
- Impedance 150Ω
- Frequency Response 8 - 30,000Hz
- Sound pressure level (SPL) 112 dB (1kHz/1Vrms)



Sennheiser HD7 DJ

Closed DJ Headphones

Designed with the working DJs in mind.

- Constructed of rugged but lightweight parts
- Elliptical, circumaural design
- Swiveling ear cups (up to 210°, both ear cups)
- Proprietary acoustics system gives you an accurate and balanced sound
- Impedance 95Ω
- Single-sided coiled cable



Sennheiser HD8 DJ

Closed DJ Headphones

Take control of the club with Sennheiser's top-of-the-line DJ model.

- Crafted from durable, high quality metal parts
- Features Sennheiser's excellent proprietary acoustics system
- Capable of very loud, high SPL
- Swiveling ear cups (up to 210°, both ear cups)
- Impedance 95Ω
- Single-sided coiled cable



Sennheiser HD650

Headphones

The ultimate in open, dynamic headphone design from Sennheiser.

The HD650s captivates the listener with their expressiveness and emotion while maintaining absolute precision and lifelike reproduction. Hand-selected, matched headphone systems with very tight tolerances (+1dB); Computer-optimised magnet systems for minimising harmonic and intermodulation distortion; Extremely lightweight aluminium voice coils ensure accuracy and fast transient response; Neodymium ferrous magnet systems for high efficiency; Specially developed acoustic silk provides uniform damping over the entire frequency range and minimises intermodulation and harmonic distortion; Elegant Silver-titanium finish with high-quality metal mesh covers for superb open and transparent sound; Extremely natural, spatial sound image with balanced, crisp bass and deep bass reproduction plus authentic voice reproduction. Includes a specially developed OFC copper cable, Kevlar-reinforced, insensitive to handling noise, and Gold-plated 1/4" Jack plug with adaptor lead to 3.5mm Jack plug.



Developed from the award winning HD600, the HD650s feature improved materials for even better sound reproduction.



Description	Code	Price (Ex VAT)
HD650	453-650	£249.16
Spare Lead	455-020	£17.80

Description	Code	Price (Ex VAT)
HD6 MIX	473-790	£145.00
HD7 DJ	473-800	£174.17
HD8 DJ	473-810	£207.50

SATURDAY DELIVERY
no problem

DELIVERY BEFORE NOON
no problem

MORE PRODUCTS
online

ALL PRICES EXCLUSIVE OF VAT.

HEADPHONES

Headphones

CONTINUED

Sennheiser HD201 Headphones

The ideal entry into the world of powerful stereo sound.

The HD 201 has good attenuation of ambient noise with outstanding wearing comfort at an affordable price. Powerful stereo sound with a rich, crisp bass response. Light weight and comfortable to wear. Extremely rugged construction protects it from wear and tear with high-quality leatherette ear pads for added comfort. 1/4 inch (6.3 mm) Jack adaptor, Gold-plated.

2-year warranty. Includes 6.3 mm stereo adaptor.

Description	Code	Price (Ex VAT)
HD201	454-210	£12.50
HD201 10-Pack	454-211	£115.00
Spare Earpads	455-010	£9.20



SENNHEISER

KRK KNS Series

Monitor Headphones

Voiced to remain true to the character of their class leading studio monitors.

Reference quality frequency response for circum-aural, closed-back, dynamic headphones. Newly developed headphone acoustical system. Utilizing the latest in acoustic foam technology for improved comfort. KRK headphones provide incredibly accurate and natural frequency response that gives you a reference standard unaffected by your location. Large dynamic range with extremely consistent low-distortion detail and clarity. Isolating memory foam in the ear cushions delivers improved low end response.



Description	Code	Price (Ex VAT)
KNS6400	390-150	£58.32
KNS8400	390-160	£83.32

Sennheiser HD215 MKII

DJ Headphones

The HD 215 has both outstanding sound characteristics and excellent attenuation of ambient noise. The rotatable ear cup for one-ear listening and the single-sided coiled cable make them ideal for DJ monitoring.

- Excellent stereo sound
- Spatial sound image
- Outstanding wearing comfort for long listening sessions
- Protective pouch included



Description	Code	Price (Ex VAT)
HD215 MKII	454-250	£57.50

Behringer HPX6000

Headphones

With these headphones, you not only get loud, clean sound – you also get deep, powerful bass.

- Superior sound quality with wide frequency response
- Adjustable headband with foldable, swiveling phones.
- 50mm neodymium drivers
- Single sided removable cable with 1/8" jack and 1/4" gold plated adapter



NEW LOWER PRICE

Description	Code	Price (Ex VAT)
HPX6000	384-000	£32.50

Sony MDR7506

Headphones

An extremely high quality unobtrusive reference headphone.

- PET diaphragm and neodymium magnets
- Response 10Hz to 20kHz
- Impedance 63Ω
- Folds for compact storage
- Soft ear cushions forms an effective acoustic seal.
- Hi-Fi performance
- Up to 1watt capability (that level would cause deafness)
- Supplied in a carrying case



ENCLOSED DESIGN

Description	Code	Price (Ex VAT)
MDR7506	424-010	£90.83

Sennheiser HD25-1 II Headphones

Designed specifically for the professional user.

The Sennheiser HD25-1 II headphones sit on the ear to provide a more direct acoustic coupling between the transducer and ear drum. By studio standards they are very compact and take up little carrying space. For convenience one earphone can be swivelled sideways for single side only. The 30Hz-16kHz frequency response is sensibly held within the limits of realistic programme material to avoid high frequency peaks which cause colouration and excessive "tizz". This is apparent in the faithful and uncoloured sound they produce. The plug-in connecting cable is made of stainless steel. Impedance 70Ω for compatibility with 8Ω headphone outputs. Very high sensitivity.



Sennheiser HD25-C II

Similar to the HD25-1 II but with a 3m coiled cable.

Sennheiser HD25-1 II Basic Edition

Basic Edition of the HD25-1 II, with a smaller cable and no spare earpads.

Sennheiser HD25 II

Similar to the HD25-1 II but with 2m steel cable, straight jack plug.

Sennheiser HD25-13 II

Closed-Back headphones ideal for ENG & Professional Monitoring, 600 Ohms.

Description	Code	Price (Ex VAT)
HD25-1 II	452-540	£132.50
HD25-C II	455-120	£132.50
HD25-1 II Basic Edition	455-110	£115.83
HD25-1 II Basic Edition Aluminium	473-090	£165.83
HD25 II	455-180	£132.50
HD25-13 II	473-780	£137.50
Spare Lead 40180	900-054	£37.40
Earpads 75527	452-940	£12.40
Capsule 70Ω 542121	452-960	£79.80

ENCLOSED DESIGN

SENNHEISER

AKG K267 Tiesto

Headphones

Same basic spec as K67/K167 but with the following differences:

- Additional soft headband cushioning spreads the load and is more comfortable
- Dual Plug-In feature that allows alternate cable dressing from either left of right side
- Adjustable Bass Boost, Stage, Club, Studio
- Response 5 - 30000 Hz
- Cable length 4.3m.
- Includes straight and curly plug in cables



NEW LOWER PRICE

AKG K167 Tiesto

Headphones

Similar spec to K67 but with the following differences:

- Frequency response 10 - 27000Hz
- 50mm transducers
- Cable, 4.3 m long fixed not unpluggable

NEW LOWER PRICE

AKG K67 Tiesto

Headphones

Ideally suited to the DJ with their closed back design, folding mechanism and sheer quality.

- 40 mm transducers
- Closed design for better bass response
- Impedance 32Ω
- Response 16 - 24000 Hz
- XRP3 glass-fibre reinforced polymer parts
- 1/4" and 3.5mm Mini Jack plug
- Replaceable Leatherette earpads
- Cable length 1.8m not unpluggable



Description	Code	Price (Ex VAT)
K67 Tiesto	469-370	£54.17
K167 Tiesto	469-360	£99.17
K267 Tiesto	469-350	£224.17

Behringer HPX2000

Studio Headphones

High-definition DJ headphones for demanding users in home and live applications.

- Superb frequency response, with high-efficiency cobalt capsule
- Single-sided oxygen-free copper cord
- Flexible turnable and foldable round-shaped ear cups
- Earpiece diameter is 40mm and will each handle 100mW of power.



NEW LOWER PRICE

Description	Code	Price (Ex VAT)
HPX2000	370-180	£12.50

CAN Retro
Classic Headphones

The CAN Retro gives you the perfect combination of headphones that look as good as they sound.

CAN headphones are known for sound quality, wearer comfort, long-term reliability, and of course attractive good looks. And with soft leather earpads giving you such a comfortable listening experience, you won't want to stop the music! Try the CAN Retro headphones for superb audio quality and great value for money.

Single-sided cable 1.2m long; Rugged steel head frame design; High output driver units with neodymium magnets; Great separation; Frequency response 20Hz to 20kHz.

Description	Code	Price (Ex VAT)
Retro	288-000	£12.08
Retro - 10 Pack	288-001	£99.17



Behringer HPS5000

Studio Headphones

Custom designed to meet and exceed the expectations of the most discerning audiophiles

- High quality and superb frequency response
- Ultra-wide frequency response, well defined bass and super-transparent highs
- High-efficiency cobalt capsules.
- Single-sided cord with oxygen-free copper wires and optimized oval-shaped ear cups



ENCLOSED DESIGN

Description	Code	Price (Ex VAT)
HPS5000	381-180	£15.83

Behringer HPS3000

Studio Headphones

Superb frequency response meeting the high demands of professional studio users.

- High-efficiency cobalt capsule, with high dynamic headroom
- Single-sided oxygen-free copper cord
- Optimised oval-shaped ear cups
- Earpiece diameter is 40mm and will each handle 100mW of power.
- Impedance: 64Ω, 1/4" stereo jack.



NEW LOWER PRICE

Description	Code	Price (Ex VAT)
HPS3000	370-190	£13.32
HPS3000 6-Pack	370-196	£74.17

CAN Flex

Flexible Headphones



CAN Flex headphones epitomise the quality of the CAN range, with impressive sound quality bringing to life punchy basslines and crisp clean highs. The swivelling, foldable and reversible design offers the maximum flexibility of use in different situations. Suitable for use pretty much anywhere you might take your ears, the soft leather ear pads ensure they'll be listening in comfort! Swivelling and foldable design with high output neodymium magnet drivers. Soft leather earpads. Frequency response 20Hz to 20kHz. Cable length 1.2m

Description	Code	Price (Ex VAT)
Flex	288-010	£8.29
Flex - 12 Pack	288-011	£72.50

CAN Lifestyle

Lightweight Personal Headphones

Audibly impressive and affordable, Lifestyle headphones bring a quirky original look to the usually fairly boring world of lightweight headphones!

- The sound quality is impressive compared to others in its class
- Frequency response 15Hz to 20kHz
- Cable length 1.2m
- Swivelling earcup design
- High output neodymium magnet drivers
- Soft leather earpads



Description	Code	Price (Ex VAT)
Lifestyle	288-030	£9.96
Lifestyle - 10 Pack	288-031	£79.17

Behringer HPM1000
Headphones

Multi-purpose headphones designed for semi-pro-level users.

They feature an ultra-wide frequency response, high dynamic range, a high-resolution capsule and oval-shaped ear cups with a comfortable headband. The frequency response is 20Hz - 20kHz. Impedance 64Ω.

Includes Mini Jack to Jack adaptor.

Description	Code	Price (Ex VAT)
HPM1000	381-190	£8.32
HPM1000 5-Pack	381-195	£38.30



MORE PRODUCTS online

HEADPHONES

Headphones

CONTINUED

Numark HF125

DJ Headphones

Quality DJ Headphones from one of the top names in DJ equipment.

Featuring:

- Flexible 7-position independently adjustable dual ear cups
- Large 40mm Mylar speaker drivers
- 6ft tangle-resistant cord with 1/4" jack plug
- Padded headband and ear cups
- Minijack plug and adapter not included

Description	Code	Price (Ex VAT)
HF125	276-000	£5.78
HF125 - Pack of 6	276-006	£31.20



Numark

Numark HF150

Headphones

Numark's most portable DJ headphone yet.

- Foldable design
- On-ear cups provide exceptional noise isolation and portability
- Ideal for the travelling DJ and highly portable setups
- Rotating earcup
- 40mm driver delivers deep, defined bass for beatmatching
- 20 Hz - 20 kHz frequency response
- Leatherette earcups
- 32 ohm impedance
- 4ft (1.2m) cable with 1/8-inch (3.5mm) stereo plug



Numark HF325

On-Ear Headphones

Packs an incredible amount of sound quality into a compact, noise isolating design.

- Studio-grade acoustics
- On-ear cups provide exceptional noise isolation and portability
- Exceptional handling power for use with pro mixers and controllers
- Rotating earcup
- 40mm driver delivers deep, defined bass for beatmatching
- 20 Hz - 20 kHz frequency response
- Leatherette earcups
- 32 ohm impedance



Numark HF350

Around-the-Ear DJ Headphones

The sound source you can trust for high-pressure performance.

- Around-the-ear cups provide long-term wearing comfort
- Exceptional handling power
- 40mm driver delivers deep, defined bass for beatmatching
- 20 Hz - 20 kHz frequency response
- Aggressive isolation for use in noisy environments
- 32 ohm impedance
- Rotating earcup
- Immediate, up-front sound signature gets you closer to the mix



Description	Code	Price (Ex VAT)
HF150	277-630	£19.16
HF325	277-640	£37.49
HF350	277-650	£45.83

AKG K44

Home Recording Headphones

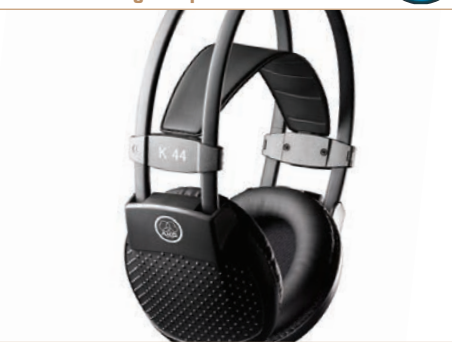

The K44 are cost-efficient headphones for different applications, like Project Studios and Home Recording. These closed-back headphones are a true all-round performer with solid bass and clean highs at a value price. The AKG self-adjusting headband, leatherette ear pads, and gimbal suspension ensure good comfort.

Description	Code	Price (Ex VAT)
K44	439-820	£17.92

AKG K77

Monitoring Headphones

The newly designed K77 are cost-efficient headphones for various applications.

These closed-back headphones are an all-round performer with solid bass and clean highs at a valuable price. A self-adjusting headband, leatherette earpads, and gimbal suspension ensure excellent comfort.



Description	Code	Price (Ex VAT)
K77	439-830	£24.17

AKG K240 Studio

Headphones

Designed for professional applications such as mixing, mastering and playback.

- Over-ear design
- Semi-open technology
- Patented Varimotion 30 mm XXL transducer
- Self-adjusting headband
- Single sided cable
- Frequency 15 to 25000 Hz
- Impedance 55 Ohms
- Max. Input Power 200 mW
- 3m cable included



Description	Code	Price (Ex VAT)
K240	469-380	£82.50

Sennheiser HD380

Pro Monitoring Headphones

Collapsible high-end headphones providing excellent passive attenuation of ambient noise.

- Ideal for professional monitoring use
- Utilising Sennheiser's Ergonomic Acoustic Refinement (E.A.R) design
- High sound pressure level (up to 110dB)
- Lightweight and secure-fit design
- Includes carry case and coiled cable



Description	Code	Price (Ex VAT)
HD380	455-160	£90.82

Sennheiser HD439

Headphones

Closed back headphones where low frequencies receive special attention.

- Neodymium magnets for enhanced bass
- Design isolates against ambient noise
- Optimised for portable audio including MP3, CD players, iPad, iPod, iPhone and mobile phones
- Impedance 32Ω. Response 17-22500 Hz
- Sound pressure level (SPL)112 dB
- 1.4m & 3m single-sided detachable OFC cables



Description	Code	Price (Ex VAT)
HD439	473-080	£66.66

Sennheiser HD205

DJ Headphones

Provides an excellent sound quality and brilliant shielding of ambient noise.

- Medium-sized dynamic, supra-aural headphones
- For compact systems or mobile players (32ohm)
- Outstanding passive attenuation of ambient noise
- Rotatable ear cup for one-ear listening
- Convenient protective pouch included
- 3.5 mm jack plug and 1/4" (6.3 mm) screw-on jack adaptor, gold-plated
- Single-sided cable



Description	Code	Price (Ex VAT)
HD205	454-280	£31.24

AKG K612

Pro Monitoring Headphones

Reference open, over-ear phones that deliver natural sound imaging for professional monitoring.

- The advanced open technology offers comfort for long working sessions and a full, spacious sound.
- Self-adjusting real leather headband
- Varimotion Diaphragm Technology assures high quality imaging and sound
- Frequency response 12 - 39500 Hz
- Max input power 200mW
- Impedance 120Ω
- 3m attached
- K712 and K812 also available. Please see our website for details



Description	Code	Price (Ex VAT)
K612	469-210	£124.17

M-Audio HDH-50

High Definition Headphones

Bridges the gap between studio monitor engineering and private audio.

- Premium build quality and tuning with 12Hz-24kHz frequency response
- Powerful 50mm drivers with neodymium magnets offer an immersive audio experience
- Built to last with rugged aluminum and steel construction
- Plush leather cushioning with a comfortable over-the-ear design
- Audio cable with 1/4" adapter included
- Communication cable with built-in microphone included



Description	Code	Price (Ex VAT)
HDH-50	374-250	£99.17

HEADPHONES

Earphones

Roland CS-10EM

Binaural Mics/Earphones

Combines ear monitoring and binaural recording, enhancing the ease and enjoyment of recording on the go.

- All in one design
- A great companion for the Roland R-05 and R-09HR field recorders
- Compact, high-quality stereo condenser mic built into earphones
- Includes carrying pouch
- Powered by the recorder (operating voltage is 2V to 10V)



Description	Code	Price (Ex VAT)
CS-10EM	369-900	£65.83

FREE
catalogue

Are you reading someone else's catalogue? Why not call us and order your own copy...

it's free!

CAN MYWORLD

Personal In-Ear Stereo Earphones



In keeping with the design values of the CAN range, Myworld earphones combine brilliant-sounding audio quality and impressive bass response with a stylish white and silver aesthetic design.

Attention to detail is important, with 3 different sizes of earbuds ensuring a comfortable fit whether your ears are more pixie or cauliflower, and a movable cable stopper to keep the cable exactly where you want it.

- 8.5mm neodymium driver units
- Frequency response 10Hz to 22kHz
- Comfortable silicon earbuds
- Cable length 1.2m

Description	Code	Price (Ex VAT)
MYWORLD	288-040	£6.66
MYWORLD x10	288-041	£54.17

HEADPHONES

Headphone Amplifiers

Focusrite VRM Box

Monitoring System

A unique solution for reference monitoring featuring virtual speakers.

- 3 virtual rooms and 15 virtual speakers
- SPDIF input - use with any audio interface with an SPDIF out
- High quality headphone output with 108dB dynamic range
- USB bus powered and highly portable



Description	Code	Price (Ex VAT)
VRM Box	389-760	£41.66

Studiospares HA20

Headphone Amplifier



The HA20 is a truly professional headphone amplifier housed in a sturdy aluminium case with aluminium extrusions either end. Inputs via XLRs, outputs via jack sockets. Front panel includes, volume, stereo/mono switch plus L and R XLR headphone inputs. Can be powered by a 9volt PP3 battery or via the power supply included. Response 30Hz - 20kHz +/- 2dB. Drives any headphones down to 12Ω. Input voltage Nominal 0dBv Maximum +4dBv. Maximum output wattage into 20Ω 50mW per channel. (Could cause permanent ear damage with sustained listening at this level)

Description	Code	Price (Ex VAT)
HA20	449-760	£39.50

Studiospares HAR4/HA4
4-Way Headphone Amplifier



Four flexible channels with EQ and mix covering all applications.

Each channel includes a main buss input plus an Aux input, EQ with boost and cut, Mute on L and/or R and volume control. LEDs to indicate signal level on Clip. Main input also includes LEDs to optimise the HAR4 with external equipment.

HA4

A basic headphone amplifier which gives excellent account of itself. Will easily drive all headphones to full volume. Line level Phono inputs and Stereo/Mono switch on the rear panel. Power supply included.



Description	Code	Price (Ex VAT)
HAR4 Rackmount	449-340	£72.50
HA4	449-330	£19.90



SATURDAY DELIVERY
no problem

DELIVERY BEFORE 10AM
no problem

ALL PRICES EXCLUSIVE OF VAT.

HEADPHONES

Headphone Amplifiers

CONTINUED

Behringer P16 Series Headphone Amplifiers



The easy, affordable way to give your musicians and vocalists the mix they really want. Ideal for use with Behringer mixers, such as the X32.

Behringer P16-I 16-Channel Personal Mixer



Connects to the main mixing console, and up to six P16-M Personal Mixers, creating a system big enough to equip a typical recording studio, a small to medium-sized band, or a worship team. Converts 16 analog inputs into 24-bit digital audio to be transmitted via standard CAT5e cable. 2 x 8-channel ADAT optical inputs with auto detect and priority select. 16 balanced, TRS audio inputs. Digital inputs support 44.1 and 48 kHz sample rates. Ultra-low system latency.

Behringer P16-M 16-Channel Personal Mixer



P16-M Personal Mixers let each performer take control of what they hear, allowing the engineer to concentrate on providing the audience with the best possible listening experience. As a performer, you know what you need to hear in order to perform your best. The P16-M's intuitive user interface makes it easy for musicians and singers to dial in their perfect monitor mix. And if you've got a really big show to do, it's a comfort to know you can daisy-chain up to 48 of them. Take it from us, if you want a personal monitoring solution with features and performance rivaling systems costing much more, check out Behringer's Powerplay 16 P16-M.

Behringer P16-D 16-Channel Ultranet Distributor



Distribution Hub for P16-I for system expansion. One ULTRANET input feeds 8 ULTRANET outputs (RJ-45). Provides bus-power and 16-channel signal transmission for all 8 outputs. Up to six P16-D ULTRANET Distributors can be combined for a total of forty-eight P16-M Personal Mixers. Status LED indicators for RJ-45 input and 8 RJ-45 outputs. Internal autorange power supply for maximum flexibility (100 - 240V), noise-free audio, superior transient response plus low power consumption for energy saving. Extremely rugged construction ensures long life even under the most demanding conditions.

Description	Code	Price (Ex VAT)
P16-I	383-020	£162.50
P16-M	383-030	£157.50
P16-D	383-040	£74.17
P16-MB Mounting Bracket	383-050	£24.17



Presonus HP60

Headphone Amplifier



Flexible and advanced 6 channel headphone mixing system.

- Six independent headphone amplifiers
- Dual stereo inputs plus external inputs for each channel
- Allows you to mix between three stereo audio streams
- Talkback via external XLR microphone input
- Each channel features headphone level, mix control between A and B inputs, external input volume, mute and mono

Description	Code	Price (Ex VAT)
HP60	328-380	£207.50

Presonus Monitor Station

Headphone Amplifier

The ultimate desktop monitoring and communications system for your recording studio.

- Based on the popular Central Station
- Provides talkback and speaker switching
- Input source switching and four ultra loud and clear headphone amplifiers
- 3x stereo inputs
- 3 sets of TRS speaker outputs



Description	Code	Price (Ex VAT)
Monitor Station	328-400	£199.17

Presonus HP4

Headphone Amplifier

Answers the need for a headphone amp with professional specifications in a small package.

- Four discrete headphone outputs on the front panel each with its own volume potentiometer and 150mW amplification per channel
- Adjustment over control room monitors with a separate volume control, monitor mute switch and mono switch
- Mono or stereo operation; monitor mute switch; daisy chain an infinite number of units



Description	Code	Price (Ex VAT)
HP4	328-060	£74.17

Fostex PC1ex

Monitor Volume Controller

Remotely controls the volume of both left and right speakers.

- Passive type. No need for battery
- Robust metal chassis and machined aluminum knob
- Included are a Stereo mini cable (80cm) and 2 x RCA Pin Cable (100cm)



Description	Code	Price (Ex VAT)
PC1ex	229-290	£16.66

SM Pro HP12E

Matrix Headphone Amplifier



Accommodate 12 users with each of six output channels feeding two sets of headphones; A/B source monitoring is selectable per channel.

- Can be daisy chained
- 6 x class A Headphone Amplifiers
- Level Control Per Output
- L/R Balanced XLR/Jack Inputs
- 2 x L/R 1/4" Jack Link Outputs
- Loud Output Levels with a Variety of Head phone Types

SM Pro HP6E

Matrix Headphone Amplifier



With digital control of input selection, a fifth mix input and built in flash memory, takes headphone monitoring to a new level.

- Flash memory allows for last state memory recall of the input selection for each channel
- Any of the four available audio input source signals can be routed to any of the 6 Class A headphone amps
- An additional fifth stereo signal can also be mixed into each individual headphone channel
- Multiple HP6Es can be daisy-chained

Description	Code	Price (Ex VAT)
HP12E 12 Channel	303-130	£107.50
HP6E 6 Channel	303-140	£141.60

MORE PRODUCTS online

Behringer Powerplay Pro-XL HA4700

Headphone Amplifier



The Behringer Powerplay is a high power Headphone Distribution Amplifier. You can drive up to 12 headphone sets (>100 ohms) from the 4 stereo amplifiers, each of which provide an independent stereo headphone channel with Level control, separate Aux input plus a Mix control. This means artists can set their own headphone volume and the volume of their own performance in their Cue mix. Front panel Jacks allow the engineer to pre-monitor any of the headphone mixes, while an input Jack (also on the front) allows the engineer to override the normal stereo main input with a different signal when required. The Powerplay allows musicians to hear themselves the way they want.

One of the most extensive and flexible sets of features we've seen.

Description	Code	Price (Ex VAT)
HA4700	360-770	£74.17



Art Headamp 6 Headphone Amplifier



Complete monitoring solution, with six independent headphone outputs.

- Includes XLR and 1/4" main inputs and outputs
- Individual output level control per channel
- Precision four segment LED metering per channel
- Connects and drives up to 18 headphones simultaneously

Description	Code	Price (Ex VAT)
Headamp 6	325-840	£120.83

Behringer MiniAmp AMP800 Headphone Amplifier

Boasts 4 totally independent stereo high-power amplifier sections.

- 2 balanced stereo main inputs
- Independent level and balance controls for individual mixes
- Connect a total of 8 headphones at the same time
- Parallel Link Output enables cascading several headphone amplifiers



Description	Code	Price (Ex VAT)
AMP800	380-220	£42.50



Behringer Powerplay Pro 8 HA8000 Headphone Amplifier



A professional, high-power multi-purpose 8-channel Headphone Distribution Amplifier.

- 2 selectable main inputs
- 2 headphone outputs per channel
- Dedicated direct input for each channel
- Only suitable for headphone impedances of 100 ohms or higher.

Description	Code	Price (Ex VAT)
HA8000	370-320	£82.50



Art Headamp 4 Pro 5-Channel Headphone Amplifier with Talkback

The most fully featured ultra compact headphone amplifier in its price point on the market today.

- Five Stereo Headphone Amplifiers with Independent Volume Controls
- Built In Talkback Mic
- Selectable External Mic Input Jack
- Separate Aux Inputs
- Talkback On One or All Outputs
- Listen to Any or All Aux Inputs
- Remote Footswitch Jack
- Phantom Power On External Mic Input



Description	Code	Price (Ex VAT)
Headamp 4 Pro	326-080	£95.83



Behringer MicroMon MA400 In-Ear Monitor Headphone Amplifier

The ideal personal monitor mixer for the performer who always asks for "more me."

- Ultra-compact monitor headphone amp
- Personal mixer lets you mix a mic plus a monitor signal out via headphones
- Flexible Mic In and Mic Through connectors plus Ground Lift switch
- Stereo Monitor Input with dedicated Monitor Level control and Mono/Stereo switch



Description	Code	Price (Ex VAT)
MA400	380-800	£15.82



Behringer MicroAmp HA400 Headphone Amplifier



You can use this super-compact stereo headphone amplifier with practically all headphones-four of them at the same time, to be exact! For example, you can let up to 4 different people in your studio listen to the main mix while the recording is being made, and each listener can determine his own volume level using the dedicated output level controls. The HA400 contains 4 high-power stereo amplifiers that maintain the highest sonic quality even at maximum volume levels. Ultra low-noise 4580 operational amplifiers are included for outstanding audio performance-these are the same op amps found in full-size audio equipment-plus, a DC 12-Volt adaptor is included.

Description	Code	Price (Ex VAT)
HA400	380-280	£13.33



VISIT
our trade counter
You'll get friendly advice and immediate access to 8000+ product lines!

1000s
of products
Available from stock!

HEADPHONES

Headphone Amplifiers

CONTINUED

Behringer Powerplay P1

Personal In-Ear Monitor Amp

Provides performers and recording artists with a dependable and affordable personal monitoring solution.

- High-power headphone output
- Built-in current limiter
- Dual XLR inputs allow 2-channel, mono or stereo operation with a convenient mix function
- Level and Balance controls
- 9 V battery powered
- Metal chassis construction



Description	Code	Price (Ex VAT)
Powerplay P1	384-350	£37.50

Samson S Phone 4 Channel

Headphone Amplifier



Provides tremendous flexibility for monitor and cue mixing.

- Versatile single rack space four channel headphone amplifier
- Each channel includes three Headphone Outputs with an overall Volume control and individual Level meters
- A convenient Stereo Auxiliary input is available on each channel
- Balance control adjusts the ratio of the Main and Auxiliary signal or the left to right balance
- For greater sonic control, S phone also features a 2-band equalizer on each of the four channels

Description	Code	Price (Ex VAT)
S Phone	368-550	£133.32

Samson S Amp

4-Channel Headphone Amplifier

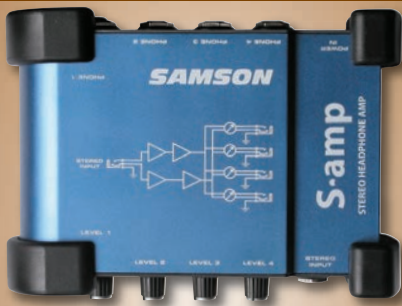

Ideal for home recording.

This 4-channel headphone amplifier features: Four 1/4" stereo headphone outputs; Individual volume control for each headphone output; Stereo 1/4" input; 18 volt AC adaptor included.

Description	Code	Price (Ex VAT)
S Amp	368-820	£37.49

MORE PRODUCTS online

Samson S Monitor

Monitor/Headphone Amplifier

An elegant solution for personal monitoring on stage or in the studio.

- XLR microphone input
- XLR microphone Thru
- microphone output to send to main mixer
- 1/4" stereo mix input
- 1/4" stereo mix Thru for daisy chaining additional units
- Microphone and Mix volume control
- Two headphone outputs
- 18 volt AC adaptor included



Description	Code	Price (Ex VAT)
S Monitor	368-850	£41.66

Korg DS-DAC100

Audio Interface/Headphone Amp

Beautiful sound and beautiful design.

- AudioGate 3 and the DS-DAC interfaces
- Realtime DSD conversion for ideal sound
- DSD native playback of 2.8224 MHz and 5.6448 MHz DSD files
- Pro-quality hardware design that builds on the achievements of the MR series DSD recorder
- Stable, dedicated Win/Mac drivers



Korg DS-DAC100M

Portable Headphone Amplifier

Approximately the same size as a portable hard disk, the DS-DAC100M contains essentially the same circuitry as the upper-level model DS-DAC-100. It provides a compact version of this high-quality audio playback system featuring the same great sound as the DS-DAC100.

Description	Code	Price (Ex VAT)
DS-DAC100	283-350	£332.50
DS-DAC100M	283-340	£240.83

HEADPHONES

Headphone Splitters

IK iLine

Headphone Stereo Splitter

A splitter lead for splitting 3.5mm Mini Jack leads.

- Moulded plugs and gold plated contacts.



Description	Code	Price (Ex VAT)
iLine	321-660	£9.99

WANT a job?

Are you looking for a stable and rewarding career?

Studiospares are constantly expanding. We require additional staff for a variety of positions, working in a very congenial atmosphere. Practical experience of recording and/or live sound engineering would be preferable.

send in your CV in the first instance

HEADPHONES

Headphone Accessories

MTR PS-4

Headphone Splitter



A simple and effective means of splitting one headphone output to up to four sets of headphones. Includes overload protective resistors so headphone should not burn out if driven from a power amplifier with the volume turned up. Passive so it requires no batteries.

Description	Code	Price (Ex VAT)
PS-4	450-530	£26.50

MTR PS-8 8 Way

Headphone Splitter

Provides an inexpensive means of powering multiple headphones.

- Includes protection resistors to stop short circuits blowing power amplifiers
- Sockets are PCB-mounted, and there is an internal link to mono the units
- Will also work in reverse as a 8 into 1 passive combiner



Description	Code	Price (Ex VAT)
PS-8	440-520	£47.50

K&M 16320

Headphone Hanger

This stable headphone holder has a 180 degree swivel and can be turned away to save space if not required.

- Size when folded: 160 x 24 x 90 mm
- Rubber covered steel plate for wall fixing



Description	Code	Price (Ex VAT)
16320	478-970	£16.50

Studiospares Headphone Hanger

Attaches to any microphone or speaker stand.

- Non marring clamp
- Never misplace your headphones again
- Caution. Keep well below eye level



Studiospares STU011

Headphone Wall Hanger

Attaches to a wall or rack.

- The hanger can be swivelled away when not in use
- The mounting holes are set for 2U spacing so can be mounted on the rack
- 2U spacing for rack mounting



Description	Code	Price (Ex VAT)
Headphone Hanger	448-030	£6.84
Headphone Wall Hanger	449-220	£8.30

Adam Hall Headphone holder

Always trying to find a convenient place to put your headphones down? Try the Adam Hall Headphone Bracket.

- Mounts over 2 units in your rack
- Swivels flat against the rack for transportation
- Can be removed entirely
- Also useful for patch cords, etc
- Black powder coated with soft PVC covering



Fitted at the wrong height there is a chance of poking your eye out, be warned!!

Description	Code	Price (Ex VAT)
Headphone Holder	441-100	£7.65

K&M 16085

Table Headphone Holder

A versatile headphone holder that keeps multiple sets of headphones close at hand.

- Headphone holder for mounting on a desk
- Space for up to two pairs of headphones
- Slots on the front in-ear pieces
- Tilttable holder 90°
- Dimension of plate 60 x 100 mm, Weight: 0.26 kg



Description	Code	Price (Ex VAT)
16085	478-740	£24.90

HEADPHONES

Ear Protection

ACS ER-20

Ear Protection

Cost effective, ready to use, one-size-fits-all earplug that closely replicates the ear's natural frequency response.

- Manufactured using medical-grade silicon
- Independently tested to conform to European standards for noise exposure
- Flattest response of any musicians' hearing protector worldwide



Description	Code	Price (Ex VAT)
ER-20	291-010	£11.80

Sparkplug Earplugs

Coloured Pair

Pair of ear plugs, for inserting into the ear canal to protect against noise according to EN352.

- Super soft, hypoallergenic polyurethane foam which are comfortable to wear
- Randomly coloured, every ear plug looks different
- Hygienically packed in a transparent bag



Description	Code	Price (Ex VAT)
Sparkplug Earplugs	255-910	£0.39
Sparkplug Earplugs 200-Pack	255-920	£49.60

ACS T15 Pair

Universal Fit In Ear Monitors

One of the most versatile Universal Fit (IEM) in-ear monitors available offering not only a universal fit, but also a custom fit option.

- Comes with a broad array of interchangeable generic tips to fit any ear
- The T15 is a silicon moulded balanced armature transducer earphone
- Custom moulds are an additional option



NEW LOWER PRICE

Description	Code	Price (Ex VAT)
T15	257-100	£104.17

SPEAKERS

Studio Monitors

Yamaha HS Series

Studio Monitors

The HS speaker range is based on a 2-way bass-reflex bi-amplified nearfield studio monitor with 5"/7"/8" cone woofer and 1" dome tweeter.

- XLR and Jack inputs.
- Same design philosophy as the NS-10
- H55 5" Woofer, 54Hz - 30kHz Power 45W LF plus 25W HF
- H57 6.5" Woofer, 43Hz - 30kHz Power 60W LF plus 35W HF
- H58 8" Woofer, 38Hz - 30kHz, Power 75W LF plus 45W HF
- Sold individually



Description	Code	Price (Ex VAT)
H55 x1	274-610	£115.83
H55 x2 + Monitor Stands	274-615	£239.00
H57 x1	274-620	£137.50
H58 x1	274-630	£193.33

Mackie CR Series Studio Monitors

Studio-quality design, sound and performance ideal for multimedia creation and entertainment.

Built using only premium, high-performance components and featuring convenient front-panel controls, Mackie Creative Reference Multimedia Monitors deliver professional sound quality and features perfect for work, play and everything in between. 50 watts of clean, articulate stereo sound and a .75" ferrofluid-cooled silk-dome tweeter. Choose which side of your desk gets the volume knob with CR3's convenient speaker placement switch. Convenient front panel volume knob with lit power ring gives you on/off/volume control and power indication where you need it. Front-facing headphone jack auto-defeats speaker output and provides tactile headphone volume control. A choice of inputs for simple connection to almost any audio source (1/4", 1/8", RCA). Smooth waveguide design delivers unmatched clarity and sound dispersion at all listening levels. All-wood cabinet provides a natural sonic character superior to low-grade plastic designs.



NEW

The Mackie CR3 features a 3" polypropylene-coated woofer with a frequency range of 80Hz - 20kHz, while the CR4 features a 4" woofer with a frequency range of 70Hz - 20kHz, perfect for full-range multimedia.

Description	Code	Price (Ex VAT)
CR3 3" pair	262-730	£82.50
CR4 4" pair	262-740	£99.17

MACKIE®

Yamaha MSP3 Single

Studio Monitor

A 2-way powered monitor speaker system that delivers quality audio and excellent cost performance.

- Designed for use in personal music production systems
- Built-in 20W amp that drives both the 4" cone and 7/8" tweeter
- Separate volume controls for the phono input and XLR/phone input
- Bass-reflex type enclosure that incorporates Yamaha's Waveguide Technology for uniform dispersion



Description	Code	Price (Ex VAT)
MSP3 Single	264-030	£142.50

Yamaha MS101 Single

Studio Monitor

The Yamaha MS101 III is a compact, convenient approach to top-quality monitoring.

- 10 watts of power
- A single 10-cm full-range driver in a bass-reflex enclosure
- A smooth response from 75Hz up to 18,000Hz
- Two line inputs - one phono and the other a 1/4" mono phone Jack
- Features full magnetic shielding
- Dimensions (W x D x H) 147 x 192 x 214mm



Description	Code	Price (Ex VAT)
MS101	274-120	£84.48

DELIVERY BEFORE NOON
no problem

SATURDAY DELIVERY
no problem

DELIVERY BEFORE 10AM
no problem

ALL PRICES EXCLUSIVE OF VAT.

SPEAKERS

Studio Monitors

CONTINUED

Genelec 8020C Single

2-Way Active Studio Monitor

Popular studio monitor softly curved edges and outstanding mechanical strength.

- 105 mm (4 inch) bass driver along with a 19 mm (3/4 inch) tweeter loaded into a new advanced Genelec Directivity Controlled Waveguide
- Free field frequency response is 66 Hz to 20 kHz (+/- 2.5 dB)
- Bass and treble are each powered by 20 watt amplifiers
- Die-cast aluminium Minimum Diffraction Enclosure which features a relatively large internal volume
- Features Genelec's Intelligent Signal Sensing (ISS)



Description	Code	Price (Ex VAT)
8020C	435-070	£274.17

Genelec 6010BPM Single

Studio Monitor

Contains its own power amplifiers, active crossover filters and automatic protection circuitry.

- Cast-aluminium Minimum Diffraction Enclosure™
- Bass response extends down to 73 Hz (-3 dB point).
- Low distortion due to a uniquely new rear reflex port design
- Xdesigned for computer sound systems and other close proximity listening applications
- Features Genelec's Intelligent Signal Sensing (ISS)



Description	Code	Price (Ex VAT)
6010BPM Black	435-000	£165.83
6010BPM White	435-010	£165.83

MORE PRODUCTS online

Studiospares Seiwin Pair
Active Nearfield Monitors

Designed for studio use at the outset...

This active nearfield monitor looks good, sounds good and even feels good. To maintain good low frequency efficiency, the acoustic principle is bass reflex with a rear facing port. The cabinet construction is solid MDF 17mm thick which is Black veneered for an appealing finish. The magnetically shielded drivers were selected for quality, not price. The 6" bass driver has a mineral-filled polypropylene cone with a high temperature voice coil and damped rubber surround. Such free movement allows the driver to move substantial amounts of air without distortion. The 1" soft domed tweeter is ferrofluid cooled. The crossover frequency is 2.6kHz. Two internal amplifiers, 80 watt for the bass driver and 40 watt for the tweeter are driven from XLR and Jack sockets. The professional line level of 0.775volts, (0dbv) delivers full output. The volume controls are rear panel mounted together with the On/off switch and mains input socket. An LED below the bass driver indicates when power is on. Each speaker is totally self contained. The overall sound is superb, partly due to the quality of the drivers and partly due to the matching of the amps to the speakers and cabinet.



BEST SELLER

Description	Code	Price (Ex VAT)
Seiwin Pair	248-030	£132.50
Seiwin Pair + Monitor Pads	248-031	£139.00
Seiwin Pair + Monitor Stands x2	248-032	£149.00
Spare PCB + Heatsink	248-036	£42.50
Spare Bass Driver	248-037	£12.45

These are not being sold via a dealer network so pricing is very competitive.

STUDIOSPARES

Genelec 1032BPM Single

Studio Monitor

These monitors sit at the top of the Near Field Monitor Stakes. Signal sensing puts speaker in standby after 30 mins silence.

- LF driver 10", HF driver 0.75"
- LF amp 180 watts, HF amp 120W
- Max SPL 113dB. Response 42Hz - 21kHz
- EQ Treble & Bass Tilt, Bass Roll-Off
- Dims mm 495H x 320W x 290D
- Features Genelec's Intelligent Signal Sensing (ISS)



Description	Code	Price (Ex VAT)
1032BPM	415-940	£1290.83

Genelec 8010

Studio Monitor

Allows professionals to work in compact studios and on the move with an accurate monitoring tool.

The ease of installation and outstanding sound quality make Genelec 8010 monitors ideal for small studios, OB vans, and perfect companions for portable recording devices and other mobile work.



NEW

With a balanced XLR input, 3-inch Woofer, 3/4-inch tweeter and efficient Class D power amplifiers - one for each driver - 8010s produce more undistorted sound pressure level than you might expect from monitors of this size. Genelec's Intelligent Signal Sensing, the ISS circuitry saves energy by automatically setting the monitor to sleep mode when an audio signal has been absent for a while. Thanks to their exceptional sound quality, small size and universal mains input voltage, 8010s are the perfect companions while on the move.

Description	Code	Price (Ex VAT)
8010 x1	435-150	£207.50

Genelec 8030BPM Single
Studio Monitors

Powerful bi-amplified nearfield monitor system!

Rated 10/10 by Future Music magazine. Replacing the popular 1029As, the very compact 8030BPM is a powerful bi-amplified nearfield monitor system ideal for project and home studios, workstations, installations, and surround sound monitoring. The 'Minimum Diffraction Enclosure' has rounded edges and a gently curved front and sides to achieve a smooth frequency response and superb imaging qualities. Like all Genelec 8000 Series monitors, the 8030BPM also features the advanced Genelec Directivity Control Waveguide, a revolutionary flow-optimised reflex port design, optimised die-cast aluminium structure with durable semi-matte finish and acoustically optimised metal grilles. If very large sound levels and a low cutoff frequency are required it can be complemented in stereo applications with the 7050A subwoofer and in surround applications with the 7060A subwoofer. Very popular and with very good reason.

Genelec's Intelligent Signal Sensing (ISS) feature, reduces power consumption to less than 0.5 watts by automatically switching the active monitor to standby, when no audio signal has been detected for some time. When it receives an audio signal again, the loudspeaker turns back on.



GENELEC®

Description	Code	Price (Ex VAT)
8030BPM	415-980	£415.83

VISIT
our trade counter

You'll get friendly advice and immediate access to 8000+ product lines!

free parking for 40 cars

Studiospares SN10 Pair

Nearfield Monitors

Inspired by the legendary Yamaha NS10!

The Studiospares SN10 addresses the two improvements that studios thought appropriate, namely an extended bass response and the need for more output. The SN10 incorporates an 8 inch driver, not a 6.5 inch. It has a massive magnet which together with the increased size uprates the power output to 80 watts. The HF output is handled by a 1" soft domed tweeter driven by the crossover which operates at 3.2kHz. The cabinet is constructed from 19mm MDF and veneered in Black. The front grille is removable. The sound is punchy and very close to the familiar NS10s. The stereo imagery is excellent and the top end is smooth. Should users manage to fry either of the speakers, it's nice to know that replacements only cost £19.50 + vat each.



Studiospares SN10A Pair

Nearfield Monitors

Same as above but includes a compact 85 watt Aktiv8 power amplifier attached to the back panel. It's high efficiency means cool running and assured reliability. XLR/Jack input and gain control.

Description	Code	Price (Ex VAT)
SN10 Pair	248-000	£82.50
SN10 Pair + Monitor Pads	248-001	£86.67
SN10 Pair + Monitor Stands x2	248-002	£98.33
SN10 Pair + Trojan Pier Monitor Stands Pair	248-007	£103.33
SN10A Pair	249-210	£165.83
SN10A Pair + Monitor Pads	249-211	£174.17
SN10A Pair + Monitor Stands x2	249-212	£182.50
Spare LF Driver	248-010	£20.82
Spare Tweeter	248-020	£19.50
Spare Grille	248-015	£5.00



"NS10 copies that sound better than NS10s... I still think these speakers are little blunders, and dare I say it... My mixes are actually tighter than they are on NS10s... I was doing FOH at Ministry of Sound and I played an SN10 mix I'd just done for The Loose Cannons on the main system and it sounded superb!! Cheers."

Bill Borez (Producer, Remixer)



JBL LSR305 Single

2-Way Active Studio Monitor

Bi-amplified Studio Monitor with Magnetically-Shielded 5" Low Frequency Woofer and 1" Soft-Dome High Frequency Tweeter.

- Class D Amplifiers provide abundant power
- Balanced XLR and Jack inputs
- -10 dB/+4 dB sensitivity ensures compatibility
- Amps LF 41W Class D. HF the same
- Max Peak SPL: 108 dB SPL C-Weighted
- Frequency Range: 43 Hz - 24 kHz
- Size 298 mmH x 185W mm x 251D mm



Focal Professional Alpha Series

Active 2-Way Nearfield Professional Studio Monitors

Alpha studio monitors are specifically designed for music creation

- 1" (25mm) aluminum inverted dome tweeter
- Polyglass cone loaded in a large laminar port
- **Alpha 80** - 8" (21cm) woofer, 40W amp (tweeter), 100W amp (woofer), freq response of 35Hz to 22kHz
- **Alpha 65** - 6.5" (16.5cm) woofer, 35W amp (tweeter), 70W amp (woofer), freq response of 40Hz to 22kHz
- **Alpha 50** - 5" (13cm) woofer, 20W amp (tweeter), 35W amp (woofer), freq response of 45Hz to 22kHz



Description	Code	Price (Ex VAT)
Alpha 50 x1	413-340	£165.83
Alpha 65 x1	413-350	£199.17
Alpha 80 x1	413-360	£232.50

Genelec M030 Active Single

Studio Monitor

The moulded cabinet with double curvatures minimises diffractions and increases cabinet rigidity.

- Integral moulded waveguide surrounds the tweeter
- Cabinet made from fully recyclable, wood-fibre-reinforced plastic composite
- Injection-moulding process allows for thicker castings than can be made from conventional plastics
- Outer walls and internal bracing are designed to effectively control resonances and maximise the internal volume vital for LF performance
- 5" Bass driver 0.75" tweeter
- Amp Bass 50 watt, Treble 30 watt
- Connections: XLR, Jack, Phono



Genelec M040 Active Single

Studio Monitor

Same as M040 but with 6.5" Bass driver and 1.0" tweeter. Amplifiers: Bass 80 watt, Treble 50 watt.

Description	Code	Price (Ex VAT)
M030 x1	435-120	£290.83
M040 x1	435-130	£432.50

JBL LSR308 Single

2-Way Active Studio Monitor

Same as LSR305 but with the following differences:

- LF driver 8" Response 37Hz - 24kHz
- Amps LF 56 watts Class D. HF the same
- Max Peak SPL: 112 dB SPL C-Weighted
- Size 419 mmH x 254W mm x 308D mm

Description	Code	Price (Ex VAT)
LSR305 x1	445-300	£95.83
LSR308 x1	445-310	£182.50

DELIVERY BEFORE NOON
no problem

ALL PRICES EXCLUSIVE OF VAT.

SPEAKERS

Studio Monitors

CONTINUED

Studiospares Seiwin 5A/SN-4A Pair

Nearfield Monitors

Part of the widely acclaimed Seiwin ST series.

Solid build, solid sound. Good power reserve with a balanced and sweet frequency response. These are not being sold via a dealer network and are imported by the container load so pricing is very very competitive.

5A Pair

The frequency response is 70Hz - 20kHz, and features a 5" magnetically shielded bass driver. 60watt LF amplifier, 30watt HF amplifier. The 5A has a 3/4" magnetically shielded Ferro-fluid cooled soft domed tweeter. Jack + XLR inputs and volume control. Dimensions 185H x 225W x 280D mm.

SN-4A Pair

The frequency response is 85Hz - 20kHz, and features a 4" magnetically shielded bass driver. 40watt LF amplifier, 20watt HF amplifier. The SN-4A has a 1" magnetically shielded Ferro-fluid cooled soft domed tweeter. Jack + XLR inputs. Dimensions 160H x 185W x 225D mm.

Description	Code	Price (Ex VAT)
5A Pair	248-040	£107.50
5A Pair + Monitor Pads	248-041	£115.80
5A Pair + Monitor Stands x2	248-042	£121.70
SN-4A Pair	248-050	£99.00
SN-4A Pair + Monitor Pads	248-051	£103.33
SN-4A Pair + Komodo 800 x2	248-052	£132.50

STUDIOSPARES

Seiwin 5A



Seiwin SN-4A

Studiospares Aktiv8 Single

Powering Unit

Activate any passive speaker by driving it with an amplifier attached to its rear panel or stand alone.

Aktiv8 is a self contained single channel power amplifier designed to power any speaker of 8Ω impedance or more. As with all high quality power amplifiers, it is based on Class A-B technology which is tolerant to speaker impedances not exactly 8Ω. Input is via a combi XLR/Jack socket and the output via a Speakloc which mates with any twist to lock speaker connector. Input sensitivity is -10dB @ 10kΩ. Power input is via a standard IEC socket. All sockets are mounted on the back panel. The front panel has an input gain control and On-Off switch and LED. It is designed such that the controls are conveniently mounted on the top whilst the connectors are mounted on the underside. Six mounting holes for fixing to the rear of the speaker cabinet.

Description	Code	Price (Ex VAT)
Aktiv8 85W RMS	249-180	£64.50



STUDIOSPARES

IK iLoud

Portable Studio Monitor

The first studio-quality portable speaker designed for musicians and audiophiles.

- 40 Watts total musical power
- Superior bass response and sound accuracy
- Bluetooth and stereo analogue line input
- Battery powered with 10 hours normal usage and auto standby
- iRig® input for guitars and dynamic mics for iPhone/iPad processing



Description	Code	Price (Ex VAT)
IK iLoud	321-770	£166.00
IK iLoud Bag	321-771	£24.17

SATURDAY DELIVERY
no problem

KRK R6 G3 Single

Passive Monitor

Top choice for accurate monitoring in studios large and small.

- 1" Neodymium Soft Dome Tweeter
- Glass Aramid Composite Cone Woofer
- Radically curved front plate design virtually eliminates diffraction distortion
- Front-firing port provides low freq extension without boundary coupling
- High Frequency Waveguide design



KRK RP10-3

Tri-Amped Powered Monitor

Provides an unsurpassed level of power, performance and accuracy.

- Rotatable MF/HF Baffle
- Front-firing Port is shape optimized
- Tweeter Waveguide design provides amazing detail and imaging
- Dedicated balanced XLR, and 1/4" Line inputs and unbalanced RCA inputs



Description	Code	Price (Ex VAT)
R6 G3	390-140	£91.66
RP10-3	390-180	£332.92

Mackie MR MKIII Series

Studio Monitors

Music-centric voicing perfect for modern mixing, monitoring and multimedia applications.

- Enhanced waveguide system
- Minimised reflections and diffractions for wider sweet spot
- Two levels of bass boost
- Boost/cut control over highs
- Drivers polypropylene woofer matched to 1" silk domed tweeter



Mackie MR5 MKIII Single

- 5.25" polypropylene woofer
- 50 watts of Class A/B amplification

Mackie MR6 MKIII Single

- 6.5" polypropylene woofer
- 65 watts of Class A/B amplification

Mackie MR8 MKIII Single

- 8" polypropylene woofer
- 85 watts of Class A/B amplification

Description	Code	Price (Ex VAT)
MR5 MKIII	262-620	£112.50
MR6 MKIII	262-630	£144.17
MR8 MKIII	262-640	£185.00

M Audio AV40 Pair

Studio Monitors

Popular monitor speakers for professional-quality media creation.

- 4" polypropylene-coated woofers deliver tight, accurate bass
- 1" ferrofluid-cooled silk cone tweeters for clear, smooth highs
- Precision imaging for balanced stereo field
- 20-watt-per-channel amplifier with Class A/B architecture
- Magnetic shielding makes them perfect for multimedia and video work



Description	Code	Price (Ex VAT)
AV40	373-120	£82.50

KRK Rokit G3 Single

Powered Reference Studio Monitors

Studio standard for many of the world's finest engineers, producers and musicians.

ROKIT Powered Monitors feature several of the key design elements found in KRK's premium models. All KRK Rokit Powered Series monitors feature a proprietary signature Yellow woofer made of a woven glass aramid composite that delivers a tight low-end response and a soft dome tweeter for natural sounding highs. Low frequency EQ provides 2dB, -1dB, 0dB and +2dB increments. The drivers are electronically crossed over and are bi-amped for increased efficiency. All of this is housed in an attractive cabinet with radiused corners that reduce edge diffraction resulting in better audio imaging. The rear input panel features phone plug and XLR connectors to accommodate any application.



KRK RP-5 G3

Studio Monitor

Woofer: 5" Glass Aramid Composite Woofer; Tweeter: 1" Neodymium Soft Dome Tweeter with Ferro Fluid; Input: XLR (3-pin), RCA & 1/4" TRS - 10kΩ Balanced / Unbalanced; Amplification: 50 Watt Bi-amp Dynamic Power 18dB Octave Filters; Frequency Response: 45Hz - 35kHz Video; Dimensions: (H x W x D) 127.6cm x 18.5cm x 22.5cm.

KRK RP-6 G3

Studio Monitor

Woofer: 6" Glass Aramid Composite Woofer; Tweeter: 1" Neodymium Soft Dome Tweeter with Ferro Fluid; Input: XLR (3-pin), RCA & 1/4" TRS - 10kΩ Balanced / Unbalanced; Amplification: 73 Watt Bi-amp Dynamic Power 24dB Octave Filters; Frequency Response: 38Hz - 35kHz Video; Dimensions: (H x W x D) 32.1cm x 22.5cm x 25.6cm.

KRK RP-8 G3

Studio Monitor

Woofer: 8" Glass Aramid Composite Woofer; Tweeter: 1" Neodymium Soft Dome Tweeter with Ferro Fluid; Input: XLR (3-pin), RCA & 1/4" TRS - 10kΩ Balanced / Unbalanced; Amplification: 100 Watt Bi-amp Dynamic Power 24dB Octave Filters; Frequency Response: 35Hz - 35kHz Video; Dimensions: (H x W x D) 38.1cm x 26.5cm x 30.4cm.

Description	Code	Price (Ex VAT)
RP-5 G3 x1	390-210	£91.25
RP-5 G3 x2 + Monitor Pads	390-211	£185.00
RP-5 G3 x2 + Monitor Stands x2	390-212	£195.83
RP-5 G3W White x1	390-215	£104.16
RP-6 G3 x1	390-220	£124.17
RP-6 G3 x2 + Monitor Pads	390-221	£254.17
RP-6 G3 x2 + Monitor Stands x2	390-222	£265.33
RP-6 G3W White x1	390-225	£137.49
RP-8 G3	390-230	£153.75
RP-8 G3 x2 + Monitor Pads	390-231	£310.00
RP-8 G3 x2 + Monitor Stands x2	390-232	£321.67

Now, you can have that same KRK sound, attention to detail and commitment at a price that makes Rokit Powered a truly uncommon value.



M Audio BX Carbon Series

Studio Monitors

Brings musicians serious mixing capability in three new models.

- Authentic, flat frequency response in a compact footprint
- Kevlar low-frequency driver
- Acoustic Space Control
- **BX5** - 5" driver, 70 Watt, frequency response 57 Hz - 22 kHz
- **BX6** - 6" driver, 130 Watt, frequency response 45 Hz - 22 kHz
- **BX8** - 8" driver, 130 Watt, frequency response 40 Hz - 22 kHz



Description	Code	Price (Ex VAT)
BX5 Carbon x1	374-220	£74.99
BX6 Carbon x1	374-230	£99.17
BX8 Carbon x1	374-240	£115.83

M Audio M3-6 Single

Studio Monitor

Delivers truly spectacular three-way sound from the same compact cabinet size as a standard two-way monitor.

- Real wood baffle; optimized internal bracing
- 6" woven Kevlar low-frequency driver and 5" woven Kevlar mid-frequency driver
- 1" silk dome tweeter with integrated waveguide
- Tri-amp Class A/B power, 160 Watts total
- XLR and 1/4" balanced inputs; RCA unbalanced input
- 3-band EQ with bypass



Description	Code	Price (Ex VAT)
M3-6 x1	374-180	£165.83

SPEAKERS

Studio Monitors

CONTINUED

KRK VXT Series

Studio Monitors

Feature several key design elements that have made KRK sounds a "studio standard".

The VXT Series monitors include radiused edges for improved imaging and slotted ports that greatly reduce distortion caused by port turbulence. What's more, they've included some valuable and practical enhancements like a speaker protection circuit for added confidence, an auto on/off feature for improved convenience and upgraded driver and amplifier components to ensure peak performance in even the most demanding professional environments.



KRK VXT4 Single Studio Monitor

Spec includes: HF 1" soft domed tweeter; LF 4" Kevlar woofer; input on XLR/1/4" TRS combo; 90W bi-amped with 12dB/octave; 236 x 159 x 197mm. Weight 5kg.

KRK VXT6 Single Studio Monitor

Spec includes: HF 1" soft domed tweeter; LF 6" Kevlar woofer; input on XLR/1/4" TRS combo; 120W bi-amped with 24dB/octave; 346 x 240 x 254mm. Weight 12kg.

KRK VXT8 Single Studio Monitor

Spec includes: HF 1" soft domed tweeter; LF 8" Kevlar woofer; input on XLR/1/4" TRS combo; 180W bi-amped with 24dB/octave; 403 x 279 x 305mm. Weight 19kg.

Description	Code	Price (Ex VAT)
VXT4 x1	390-040	£199.58
VXT6 x1	390-050	£283.00
VXT8 x1	390-060	£383.00
MBT VXT6/8 Bracket x1	390-240	£58.32



Fostex PX-5 Pair

Studio Monitors



With totally new 5.2-inch LF driver and 1-inch HF tweeters, these PX-5s realise unprecedented accurate sound reproduction and delivers class leading sonic performance. Drivers powered by a 35W (LF) / 18W (HF) digital amplifier combine with a 5.2-inch Crimson woofer constructed of aramid fibre to form the technical apparatus which produces the awesome audio. A Fade In function allows you to gradually increase the output level when powering on, while an Auto Standby function minimises electric power usage to save the environment as well as your energy bills. Practically and technically excellent, the PX-5 is the type of speaker every professional needs.

Description	Code	Price (Ex VAT)
PX-5 x2	229-320	£365.00

Tannoy Reveal 802/502/402

Studio Monitors

Studio monitor range delivering absolutely premium tonal clarity.

- 802: Custom 8" Woofer, 1" tweeter, active crossover filter, 100 watt bi-amp module, front-firing bass port
- 502: Similar to 802 but with 5" custom LF Woofer
- 402: Similar to 802 but with 3/4" soft-tweeter and 4" custom LF Woofer



NEW

Description	Code	Price (Ex VAT)
Reveal 802 x1	412-550	£174.17
Reveal 502 x1	412-540	£108.33
Reveal 502 x2 + Pads	412-541	£226.00
Reveal 502 x2 + Stands	412-542	£235.00
Reveal 402 x1	412-530	£87.50
Reveal 402 x2 + Pads	412-531	£184.00
Reveal 402 x2 + Stands	412-532	£193.00

Fostex 6301B Single

Active Speaker

Finds many applications around the industry through its convenience and all round performance.

- (20Watt peak) self powered speaker
- mains powered 10Watt RMS
- Solid metal case
- Faithful and open sound
- Front panel volume control
- Input via balanced or unbalanced Jack of -10dBm
- Compact size



Fostex 6301BX Single

Active Speaker

As above but more versatile with XLR and Jack inputs.

Fostex 6301D Single

Powered Monitor

Accepts any unbalanced input as well as AES-EBU digital input so ideal for multimedia and video presentations, as well as in project studios or on stage.

Description	Code	Price (Ex VAT)
6301B	219-071	£158.00
9610 Wall Mount	700-080	£25.00
6301BX	219-090	£165.83
6301D	219-130	£190.83

Fostex PM Series

Studio Monitors

Fostex near field monitors have always been popular in studios.

- This updated range includes class D digital Bi amplifiers
- Phono and Jack inputs @ -10dBm
- Available in Black or White finishes
- Sold as a pair



Fostex PM03D Pair

3" fibre glass woofer and a 3/4" silk domed tweeter. Amplifiers 15W LF-15W HF.

Fostex PM04D Pair

4" fibre glass woofer and a 3/4" silk domed tweeter. Amplifiers 25W LF-16W HF.

Fostex PM05D Pair

5" fibre glass woofer and a 3/4" silk domed tweeter. Amplifiers 35W LF-23W HF.

Description	Code	Price (Ex VAT)
PM03d Black x2	229-340	£70.83
PM03d White x2	229-341	£70.83
PM04d Black x2	229-350	£140.83
PM04d White x2	229-351	£140.83
PM05d Black x2	229-360	£215.83
PM05d White x2	229-361	£215.83

Akai RPM Series

Studio Monitors

Engineered for meticulous reproduction of even the most complex modern music.



NEW

Akai's RPM500 studio monitors provide the tools needed to mix with confidence. The fast Kevlar® cone provides lucid low-end agility, reproducing intricate bass patterns with ease. It's authoritative sound for the craft of music production. The RPM 500 has a 50-Watt 5 1/4-inch (133.3mm) woofer, 90-Watt distributed Class A/B amp and a frequency response from 50Hz to 30kHz. The RPM 800 has a 80-Watt 8-inch (203.2mm) woofer, 120-Watt distributed Class A/B amp and a frequency response from 38Hz to 30kHz.

Description	Code	Price (Ex VAT)
RPM500 x1	266-010	£129.17
RPM800 x1	266-020	£187.50

Behringer MS40 Pair

Monitors

Compact, super-affordable 2 x 20-watt nearfield monitors.

- Ultra-high resolution 24-bit/192kHz D/A converters
- 2 stereo analogue inputs featuring 1/8" TRS and stereo RCA connectors
- Feature individual volume controls for both Line inputs plus Bass and Treble EQ controls
- TRS headphone connector with a frontpanel auto-mute loudspeaker function



NEW LOWER PRICE

Description	Code	Price (Ex VAT)
MS40 Pair	380-140	£90.83

Behringer MS16 Pair

Studio Monitors

For home studio or multimedia applications and instrument or vocal monitoring.

- For the small home studio or multimedia applications
- 4" bass driver
- Stereo volume, bass and treble controls mounted on one speaker only
- Two stereo inputs via Phono and Mini Jack
- Additional Mono Microphone input via a Jack socket



NEW LOWER PRICE

Only one of the speakers has the controls

Description	Code	Price (Ex VAT)
MS16 Pair	370-520	£43.75

Behringer MS20 Pair

Connect digital sources directly in order to eliminate analogue line-loss and hum.

- Optical and coaxial inputs to directly connect digital audio sources by S/PDIF
- Volume controls for both Line inputs plus Bass and Treble EQ
- 24-bit/192 kHz D/A converters.
- Analogue I/P via Mini Jack and Phono



NEW LOWER PRICE

Description	Code	Price (Ex VAT)
MS20 Pair	380-150	£70.00

Avantone Mixcubes Pair

Monitors



High-resolution, full-range powered mini-reference monitors for fixed or remote locations.

- Smooth, more open, transparent top end response
- Frequency response: 90Hz - 17,000Hz (useful musical range)
- Power: 60 watts RMS
- Inspired by the legacy of the 5C Sound Cubes used in virtually all major studios for the last 25 years
- Available in Passive (Cream) and Active (Cream or Black)

Description	Code	Price (Ex VAT)
Mixcubes x2 Passive Cream	413-600	£195.83
Mixcubes x2 Active Cream	413-610	£332.50
Mixcubes x2 Active Black	413-620	£332.50
Mixcubes x1 Active Cream	413-611	£174.99
Mixcubes x1 Active Black	413-621	£174.99

Studiospares Trojan Aktiv Series
Active Nearfield Monitors

These monitors produce an accurate and transparent sound that will stand favourable comparison to products costing treble.

Coupling of the speaker cone to the air is influenced by unwanted diffraction when sound waves from the cabinet sides are scattered back into the nearfield creating phase distortion so the front surface is profiled, not flat. Titanium Tweeters provide effortless high frequencies right up to 20kHz. The fully braced cabinet reduces natural resonances. To increase LF efficiency the acoustic principle is bass reflex. Drivers are fed from individual amplifiers so problematic crossovers are eliminated. **Sold as a pair.**



Model	Bass Driver	Bass Amp	Tweeter	Tweeter Amp	Max SPL (Pair)
Aktiv5	5" Shielded	50 watts	0.75" Titanium	25 watts	106dB
Aktiv6	6" Shielded	60 watts	1" Titanium	30 watts	109dB
Aktiv8	8" Shielded	90 watts	1" Titanium	45 watts	111dB
Aktiv8SUB	8" Shielded	90 watts	-	-	110dB each

Description	Code	Price (Ex VAT)
Aktiv5 x2	248-910	£145.00
Aktiv5 x2 + Aktiv8USB + Stands x2 + RED 14 x2	248-915	£332.50
Aktiv6 x2	248-920	£166.50
Aktiv8 x2	248-930	£207.50
Aktiv8SUB Sub Woofer	248-940	£145.00

Input sensitivity -42dBu to +4dBu so can even be driven by anything. EQ controls for bass, treble and room acoustics correction. Input and Link output is via jack and XLR. An earth lift reduces ground loop problems to zero. Drivers are magnetically shielded so can be used close to TVs and video monitors. The amplifier is part of the back panel. Colour Grey with wooden sides. Individual speakers are totally self contained.

STUDIOSPARES

PMC twotwo Series

2-way Active Studio Monitors

Make choosing and using a reference monitor easier than ever before

- ATL™ bass loading technology
- Class leading connectivity – both analogue & digital up to 192kHz
- Cutting edge, audiophile, dual Class-D amplification
- Powerful DSP engine controlling driver response, crossover & EQ
- Versatile positioning
- Precision drivers designed and built by PMC
- Three models: twotwo.5 (5" driver), twotwo.6 (6" driver) and twotwo.8 (8" driver)



NEW

Description	Code	Price (Ex VAT)
twotwo.5 x2	205-000	£2750
twotwo.6 x2	205-010	£3495
twotwo.8 x2	205-020	£5475
twotwo.sub1 Active Sub	205-030	£2600
twotwo DMC Digital Controller	205-040	£4000
twotwo.remote Wired Remote	205-050	£500.00
Wall Mounting Bracket	205-060	£137.50

Alesis M1 Active Pair

Monitors

Offers an accurate response that translates well to every playback system.

- Bi-amplified Reference Monitor
- Internal active crossover and custom designed dual amplifiers
- Frequency Range: 38Hz - 23.5kHz (-10dB point)
- Combination XLR-1/4" Jack with input level control
- Dimensions: (mm WxHxD) 381 x 216 x 248
- Weight 8.9kg each
- Sold as a pair



Description	Code	Price (Ex VAT)
M1 Active Pair	415-550	£215.83

Alesis M1 Passive Pair

Monitors

Uses a proprietary 6.5 inch low frequency driver with a special mineral filled polypropylene cone, a strong linear rubber surround and a 1.5inch voice coil wound on a Kapton former.

- The tweeter is a one inch silk domed driver which is ferro cooled for extended operation
- SuperPort vent which avoids the "choking" effect of a smaller shorter port
- Power handling is quoted as 120 watts continuous programme which we translate to a maximum of 70 watts RMS



Description	Code	Price (Ex VAT)
M1 Passive Pair	415-540	£108.32

FOR
fax orders
Use our fax number..
020 8450 4390

SPEAKERS

Studio Monitors

CONTINUED

Equator D5 Pair

2-Way Active Coaxial Studio Monitors

With high-quality components, internal DSP, 100W of power and 103 dB of SPL, the D5 delivers a huge bang for a little buck.

Equator Audio's D5s (Direct 5) studio monitors are geared for the recording professional seeking a small (9.75" x 7" x 8.5"), affordable, accurate, well-voiced, reference studio monitor solution. Focused attention was paid to the development details to ensure that they deliver professional sonic performance. These monitors feature an expensive coaxially designed transducer with a 5.25" woofer and a 1" silk tweeter. The frequency response is 53Hz to 20kHz. A new cutting edge digital amplifier with breakthrough performance was designed specifically for the D5. The internal DSP allows for intricate factory adjustments.



Equator D8 Pair

Studio Monitors

100 watts of power delivering an SPL of 106dB. The largerer bass driver delivers powerful bass down to 44Hz with the tweeter response still going strong at 20 kHz. The 1.75" Tuned Front Port provides an accurate low-end extension.

Description	Code	Price (Ex VAT)
D5	413-800	£307.50
D8	413-810	£540.83



Presonus Eris E5/E8 HD Single

2-Way Active Nearfield Monitors

Studio monitors, delivering a very accurate response with a tight bass and a clear upper end.

- 5.25-inch, Kevlar low-frequency driver; a low-mass, 1" silk-dome tweeter with grille and 45+35watt Class AB amps
- Bass reflex design maximises low frequencies
- XLR/Jack balanced/Phono unbalanced inputs; Max SPL 102dB
- Controls Volume, EQ Mid, HF, Low cut
- Response 53 Hz to 22 kHz
- E8 similar to E5 but with 8 inch, Kevlar low-frequency driver; a low-mass, 1.25" silk-dome tweeter with grille and 75+65watt Class AB amplifiers



Presonus Eris E4.5 Pair

Studio Monitors

Provides an accurate response with a tight well defined bass and a clear upper end using Kevlar LF drivers and Silk Domed Tweeters.

- 4.5" bass driver + 1" silk domed tweeter
- 25 watt Class AB amplifier
- Response 70 Hz to 20 kHz.
- MAX SPL 105dB
- Dimensions 163mmW x 241mmH x 180mmD



Description	Code	Price (Ex VAT)
E5 x1	328-590	£99.17
E8 x1	328-600	£165.83
E4.5 x2	328-670	£124.17

Dynaudio BM5A MkII Single

Studio Monitor

Re-engineered to take nearfield monitoring to new levels.

- High-resolution 1.1" soft dome tweeter, pure aluminum voice coil
- Smooth and accurate HF waveguide
- Extended excursion 7" woofer, pure aluminum voice coil
- 2 channel 90-Watt transient power (2x 50W RMS)
- 117dB SPL peak power output
- Frequency response 48Hz to 21kHz



Description	Code	Price (Ex VAT)
BM5A MkII	415-420	£318.33

Behringer 1C Pair

Studio Monitors

Compact high-performance 2-way loudspeaker system!

The Behringer Monitor 1C is ideally suited for audio/video multimedia applications, home recording studios and surround-sound systems. It has a powerful 5 1/2" woofer with an extremely light-weight cellulose cone, a high-resolution 1/2" tweeter plus a phase-optimized high-precision crossover for absolute phase linearity. The result: an ultra-linear frequency response ranging from 60Hz all the way up to 23kHz. Thanks to the 1C's high power handling capability (100 Watts / IEC268-5) with auto overload protection that prevents tweeter damage and resets automatically, you get full-range output with extremely low distortion.

Description	Code	Price (Ex VAT)
1C Pair - Black	381-570	£43.75
1C-WH Pair - White	381-580	£43.75



Fostex 6301N Series

Active Monitors

Re-design of the classic 6301-series.

- 20W D-class power amplifier for higher output level
- Dedicated 4-inch full range driver
- Flat panel design to avoid level change or inadvertent power-off
- Auto Stand-by mode
- The model differences are **6301NB** (unbalanced 1/4" phone input), the **6301NE** (with electrically-balanced XLR input), the **6301NX** (with transformer-balanced XLR inputs) and the **6301ND** (with digital AES/EBU input).



Description	Code	Price (Ex VAT)
6301NB x1	229-370	£149.17
6301NX x1	229-380	£174.17
6301NE x1	229-390	£165.83
6301ND x1	229-400	£207.50
EB-6301 Mounting Bracket	229-410	£21.00

Galaxy Microspot MS5

Personal Monitor

The MS5 Micro Spot is based on the original personal monitor.

- Frequency Response: 150Hz-15kHz
- Power Handling Capacity: 100 Watts
- Sensitivity: 88dB@1watt/1meter
- High Impact ABS Plastic
- Adjustable Mic Stand/Wall Mount Bracket
- Two parallel 1/4" Input Jacks allow for daisy chaining
- 7 Position Volume Control Full on to -18dB in 3 dB steps
- Increased Low Frequency Response



Description	Code	Price (Ex VAT)
MS5	223-820	£79.17

sE Munro Egg 150 System

Studio Monitor

Designed to deliver the highest quality sound with the absolute minimum of colouration.

- Unique monocoque shell construction
- Smooth frequency response
- Ultra fast and low distortion (4*50W) with 100W/Channel headroom indicator
- Free standing control unit
- Integrated amplification with 3m matched speaker cables



Description	Code	Price (Ex VAT)
Munro Egg 150 System	422-480	£1374.17

JBL Control 2P

Powered Studio Monitors

Designed to deliver accuracy and fantastic clarity to the studio environment!

- Noticeably rich bass response
- Includes amp which produces exceptional output
- Balanced XLR, 1/4" Jack and unbalanced RCA inputs
- Stereo headphone jack means that mixes can be easily checked through headphones



Description	Code	Price (Ex VAT)
2P	445-090	£169.00

MORE PRODUCTS online

Behringer Truth B2031A Pair

Active Studio Monitors

The substantially improved successor to the best-selling B2031.

- High-resolution, active 2-way reference studio monitor
- XLR and 1/4" TRS servo balanced inputs
- Flat frequency response (50Hz - 21kHz)
- Built-in 150 and 75 Watt power amps with enormous power reserve
- Separately controlled limiters for low and high frequency overload protection
- Magnetic shielding allows placement near computer/video monitors



Behringer Truth B2031P Pair

Passive Studio Monitors

Similar to the B2031A, the passive B2031P 2-way studio reference monitor delivers very neutral sound, has an extremely flat frequency response (55Hz - 21kHz) and can handle up to 150 Watts of power. The B2031Ps are delivered as matched pairs.

Description	Code	Price (Ex VAT)
B2031A Pair	370-480	£207.50
B2031P Pair	370-490	£140.83

Behringer Truth B3031A Pair

2-Way Active Monitors

The high quality components of the Behringer Truth B3031A and its exceptionally rugged construction ensure long life.

- Tweeter, 2" velocity ribbon transducer for the ultimate in sound
- Deformation-resistant 8 3/4" Kevlar cone
- Built-in 150 and 75-Watt power amplifiers
- Inputs XLR and Jack



NEW LOWER PRICE

Description	Code	Price (Ex VAT)
B3031A Pair	382-350	£262.50

Behringer Truth B1030A Pair

2-Way Active Monitors

The Behringer Truth B1030A is an ultra linear studio monitor system with precision class A/B amplifiers with active protection circuits of 50w for LF / 25w for HF.

- Longthrow 5.25" woofer with deformation resistant Kevlar cone
- Ferrofluid cooled 1" dome tweeter



NEW LOWER PRICE

Description	Code	Price (Ex VAT)
B1030A Pair	382-560	£165.83

Behringer Truth B1031A Pair

Powered Monitors

A high-resolution, active 2-Way reference studio monitor with 8" kevlar woofer.

- Ultra-linear studio monitor with true active design
- Precision Class A/B amplifiers with active protection circuits: 100 W for LF / 50 W for HF
- 8" woofer with deformation-resistant Kevlar cone for ultimate bass response
- High-precision crossover network with 4th order Linkwitz-Riley filters
- Servo-balanced inputs with XLR, 1/4" and unbalanced RCA connectors



NEW LOWER PRICE

Description	Code	Price (Ex VAT)
B1031A Pair	383-210	£207.50

SPEAKERS

Sub-Bass Woofers

KRK 10s Single Sub-Woofer

A high power amplifier and active crossovers provide smooth and accurate reproduction.

The KRK10s powered subwoofer is the perfect complement to KRK Rokit, VXT, or any other 4 inch/8 inch studio monitor. The KRK10s is designed to extend the low-frequency performance of an existing monitor system so that the low frequency portion of the mix can be properly engineered. The KRK10s also feature a great looking cabinet that echoes the curved edges of the Rokit and VXT monitors. The front firing bass port and KRK's trademark yellow glass-aramid composite woofer ensure accurate and powerful low-end punch. A sturdy grill protects the woofer and adds to the sleek appearance of the unit. 225 Watt (Peak) RMS.



KRK 12s Sub-Woofer

An efficient and low distortion 225-watt amplifier makes the KRK12s perfect for project and professional studio applications that require increased signal pressure. The front-firing bass port and KRK's light weight and 12" high strength Kevlar woofer ensure a dynamic low-end punch. The KRK 12s has extensive bass management utilizing a full phase adjust and reverse, LFE input capability, internal and defeatable Limiter, and both balanced and unbalanced inputs. In addition the subwoofer has an internal crossover which can be switched in and out of the path when muting the sub which allows full range material to be compared with and without subsonic content. A sturdy grill protects the driver cone and adds to the sleek appearance of the unit.



KRK 12sHO Sub-Woofer

The KRK12sHO powered subwoofer is the perfect High Output choice for professional studios, where ultra-accurate bass extension and maximum sound levels are required. Powered by a massive 400 watt amplifier and a strengthened version of our signature Kevlar woofer, the KRK12sHO is the no-compromise way to hear what is happening in the depths of your mix. Subwoofers allow you to use smaller main monitors, make it possible to monitor the essential low frequency range and can be a great solution for space-challenged control rooms or mixing environments.



Description	Code	Price (Ex VAT)
10s Single	390-130	£265.83
12s	390-190	£582.50
12sHO	390-200	£1082.50

Genelec 5040BPM

Sub-Woofer

Compact subwoofer designed to complement up to five 6010B's with accurate and dynamic bass response reaching down to 35 Hz.

- Response Main 35 - 85 Hz (± 3 dB)
- Phase change 0 to -270° (90° steps)
- 6.5" Woofer in a Bass reflex cabinet
- 40 watts output. Size mm 251H x 305D
- I/Os: 5.1 RCA analogue in, 1 x 3.5 mm stereo jack in, 5 x RCA analogue out



Description	Code	Price (Ex VAT)
5040BPM Black	435-030	£357.50
5040BWM White	435-040	£374.17

Yamaha HS8S Single

Sub-Woofer

8" bass-reflex powered subwoofer delivers low frequencies down to 22Hz.

- 22Hz - 150Hz frequency response
- High-power 150W amplifier exclusively designed for low frequencies
- LOW CUT switch, LOW CUT control (80-120Hz) HIGH CUT control (80-120 Hz)
- PHASE switch
- XLR and TRS phone for inputs and XLR for outputs.



Description	Code	Price (Ex VAT)
HS8S x1	274-640	£316.67

DELIVERY BEFORE NOON
no problem

SATURDAY DELIVERY
no problem

ALL PRICES EXCLUSIVE OF VAT.

SPEAKERS

Studio Monitor Accessories

Yamaha NS10M Spare Tweeter



Spare Tweeter

Unfortunately the popular Yamaha NS10 series have now been discontinued by Yamaha. However the equally popular replacement tweeters are still available!

Description	Code	Price (Ex VAT)
NS10M Tweeter x1	415-160	£58.00
NS10M Tweeter x2	415-162	£109.00

Speaker Bracket MKII

Swivel/Tilt Wall Bracket



Wall support for standard speakers.

Load capacity 15kg. Supplied with locking screws for a better grip. Tilts speaker up to 30 degrees. Dimensions : Speaker Clamp size = 195mm fully closed 360mm fully open, mounting plate 240mm H x 120mm W.

Full length of bracket 400mm - 465mm.

Description	Code	Price (Ex VAT)
Speaker Bracket - Single	255-430	£25.30

Studiospares RED10/RED14
Monitor Isolators

Improve the sound of your speakers, with these unique monitor isolators!

Isolating your speakers from what they are placed on will greatly improve the definition of what you are hearing and give a better bass response, leading to a much more accurate mixing environment and for live situations an overall improved sound.

RED10 Dimensions - 190mm width x 237mm deep x 75mm high.
RED14 Dimensions - 385mm width x 275mm deep x 75mm high.

Description	Code	Price (Ex VAT)
RED10	465-250	£18.75
RED14	465-260	£24.92



The Studiospares Monitor Isolators are made from a 3 layer sandwich construction of 66mm foam, 3mm steel & 3mm rubber.

STUDIOSPARES

B-Tech BT12 2-Way

Speaker Control

This simple and neat controller is designed to let you hear your hi-fi in another room with a second pair of speakers.

- 1+2 mode allows you to hear both pairs of speakers or separately.
- Suitable for speakers from 4 ohms to 16 ohms; 150 watts RMS per chan rating.



Description	Code	Price (Ex VAT)
BT12	426-320	£11.30

Focusrite VRM Box

Monitoring System

VRM stands for Virtual Reference Monitoring, and enables you to hear your mix on multiple sets of speakers, in different rooms, just using headphones.

- High-quality USB headphone interface
- Compact and portable
- USB bus-powered
- 108dB dynamic range



Description	Code	Price (Ex VAT)
VRM Box	389-760	£41.66

SM Pro Nano Patch Plus

Stereo Controller

Ideally suited to being connected between a computer audio interface/soundcard master outputs and a pair of active monitors or to the input of the power amplifier.

- 2 channel analogue passive volume control
- Allows the digital device to work with a larger bit depth. No active circuitry. Mute facility
- XLR/Jack/MiniJack inputs. Jack/MiniJack outputs



SM Pro Active Speaker Starter Set

Studio Monitor Enhancement Pack

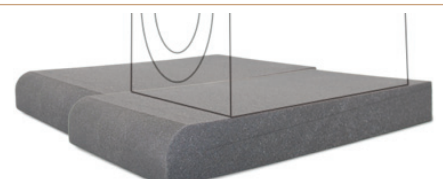

If you own a pair of studio monitor speakers, then this pack is perfect for you. SM Pro's Active Speaker Pack will improve the quality of your home studio with a pair of isolation pads for your monitors, their Nano Patch + volume controller, and four 3 metre cables to make it operational. A great value pack, providing a genuine enhancement to your home studio usability.

Description	Code	Price (Ex VAT)
Nano Patch Plus Black	303-060	£41.65
Nano Patch Plus White	303-070	£41.65
Speaker Starter Set	303-050	£58.32

Drawmer MC2.1

Monitor Controller

Four inputs with three stereo balanced speaker outputs, plus a dedicated mono speaker/subwoofer output each with individual left/right trims.

- Mix checking facilities including Left/Right Cut, Phase Reverse, Mono, Dim, Mute
- Internal headphone routing
- Two headphone amplifiers with level controls
- Built in talk back mic with level control



Description	Code	Price (Ex VAT)
MC2.1	379-630	£395.00

Studiospares Monitor Pads Pack of 4
Monitor Support

Keep the sound coming from the speakers, not the surface they are standing on...

Everything that can vibrate colours sound. That includes the surface the monitors are mounted on. These monitor pads decouple the energy from the supporting surface. OK for speakers up to 20kg. Dims of supporting area, 280mm long x 100 mm wide by 25 thick. Pack of 4 pieces allows 2 to be mounted under each monitor.

Description	Code	Price (Ex VAT)
Pads x 4	465-110	£12.46



STUDIOSPARES

DELIVERY BEFORE 10AM
no problem

SATURDAY DELIVERY
no problem

Monacor SPS-40S/80S

Speaker Switcher

For connecting up to 4 or 8 pairs of speakers (4-8 Ω) in any combination to 1 stereo amplifier output.



- With built-in power protective resistors
- SPS-40S: Connects 4 pairs of speakers; Music power: 200 WMAX; Dimensions: 176x50x100 mm; Weight: 615 g
- SPS-80S: Connects 8 pairs of speakers; Music power: 300 WMAX; Dimensions: 310x60x115 mm; Weight: 1.1 kg

Description	Code	Price (Ex VAT)
SPS-40S	256-700	£29.95
SPS-80S	256-710	£49.95

SM Pro M-Patch V2/2

Monitor Controller

A useful tool in the control room for routing various sources to the monitors.



- Placed before the input to the monitor amp
- Inputs A via XLR/Jack combo. B Aux via Phono's. Individual gain controls
- Switchable outputs 1-2 XLRs for 2x amps
- Mute facility. Stereo/Mono switch
- Headphone output with volume control
- M-Patch 2 same as M-Patch V2 but in a different shaped box

SM Pro M-Patch 2.1

Passive Monitor With Sub Woofer Connection

Introduces a sub woofer into the signal path.



- Passive circuitry so no noise or degradation
- A/B mixes with and without subwoofer
- XLR/Jack, Mini Jack and phono connectors
- Use subs or M Patch 2.1 variable crossover

SM Pro M-Patch 4M

Passive Controller/Switcher with Talkback

Delivers an all-in-one solution: monitor control with mute, mixing, level-matching, headphone monitoring, stereo- to-mono summing, and talkback



- Control room outputs are automatically ducked 20dB when talkback is engaged
- Built in mic or use your own. Headphone o/p
- Dual Output Selector Switches Stereo/Mono & All Mute Switches
- Ins/outs via XLR, Jack, Mini Jack and Phono's

Description	Code	Price (Ex VAT)
M-Patch V2	303-000	£124.96
M-Patch 2	303-010	£91.65
M-Patch 2.1	303-020	£199.99
M-Patch 4M	303-030	£216.65

Studiospares Isolation Riser

Monitoring System

Stopping the bass thump of speakers and cabinets resonating through a building has never been easier.



- A sandwich of carpet, plywood and foam
- Carrying handle built in
- Design is inherently stable
- Maximum loading 135kg placed centrally
- Dimensions mm 570W x 370D x 68H

Description	Code	Price (Ex VAT)
Isolation Riser	465-310	£24.95

Studiospares Isolation Pads Pair

Monitor Isolation Pads

Effective decoupling of the cabinet vibrations from the supporting structure



NEW LOWER PRICE

- Eliminates sounds reaching supporting structure adding clarity to the sound
- Great for desktop and close monitors
- 2 parts. Allows speaker to be angled forward or remain flat.
- Dims 5" mm 170W x 300D x 40H
- Dims 8" mm 390W x 280D x 40H

Description	Code	Price (Ex VAT)
5" Isolation Pads	465-410	£8.33
8" Isolation Pads	465-420	£12.49

Hosa SLW-333

Audio Selector

Enables you to switch back and forth, noiselessly, between up to three powered monitors.



- Powered monitor switcher
- Versatile design
- 1 IN (source) and 3 OUT (destination) but can be used in reverse to give you 3 IN (multiple sources) to 1 OUT (a single destination)
- 1/4" Tip-Ring-Sleeve (TRS) stereo Jacks
- No power required
- Rugged metal enclosure

Description	Code	Price (Ex VAT)
SLW-333	596-400	£79.50

Behringer Ultradrive Pro DCX2496

Professional Loudspeaker Management System



NEW LOWER PRICE

Digital loudspeaker management system with impressive audio quality and a great feature list.

- Installation contractors and live-sound engineers will find it invaluable
- Signals can be split in various ways to assure precise sound by using the optimal frequency range of each loudspeaker
- 3 analogue inputs and 6 analogue outputs, extreme dynamic range of 113dB
- Precise dynamic EQs, selectable for all inputs and outputs, along with zero-attack limiters on all output channels, guarantee optimal signal and loudspeaker protection

Description	Code	Price (Ex VAT)
DCX2496	370-330	£166.66

SPEAKERS

PA Speakers

JBL Eon 515XT Single

Powered Speaker

With line level and direct mic input, an on-board 3-channel mixer and unique signal flow functions, the EON 515XT was engineered for durability, high performance and ease of use.



- 625 watt high-performance powered speaker system
- Highly designed composite enclosures for durability, lightweight, and precise acoustic performance
- True portability weighing only 14.8kg

Description	Code	Price (Ex VAT)
EON 515XT 15" x1	445-240	£440.83

Samson Auro Series

PA Speakers

When Pro-Quality sound is a must, the Auro range delivers. Designed to produce the key elements of power, portability and exceptional sound, the Auro 2-Way Passive Loudspeakers are compact enclosures that combine superior components and meticulous engineering. They provide a versatile speaker solution that integrate easily into a PA setup.

Samson Auro D412/D415

Compact, lightweight 2-way passive loudspeaker system.



- 12-inch/15-inch extended range low frequency driver
- 1.34-inch (34mm) compression driver with 1-inch exit
- 400 watts of RMS power handling
- 1/4-inch connectors
- 13/8-inch pole mount receptacle
- Two oversized ergonomic carry handles
- Solid polypropylene construction

Samson Auro D208A/D210A

Compact enclosures that combine superior components and meticulous engineering.



- 2-Way Active Loudspeakers
- Immersive, articulate bass and sweet, lucid highs create well-balanced and expressive audio
- Mic/Line input with Volume control and Clip LED
- Extended range low frequency drivers

Samson Auro D1800

Sub-Woofer

Provides amazing lows that will bring the bottom-end of your PA setup to life.



- 500 watts RMS and 1000 watts peak of Class D power
- 18-inch low frequency transducer with 3-inch voice coil
- Fixed frequency (126 Hz, 24 dB/octave) electronic crossover
- Solid 3/4-inch plywood construction with textured finish

Description	Code	Price (Ex VAT)
D412 12"	388-610	£183.33
D415 15"	388-620	£190.83
D208A 8"	388-800	£100.00
D210A 10"	388-810	£141.67
D1800 Sub-woofer	388-730	£499.99

1000s
of products
Available from stock!

SPEAKERS

PA Speakers

CONTINUED

Studiospares Fortissimo Range

PA Speakers

The first of the new generation of highly portable speaker enclosures!

Fabricated from a particularly dense material that includes moulded in internal cabinet bracing to reduce cabinet resonances to an absolute minimum. Based on the legendary FB1000 series of drivers with their deep multi stage roll surround which is highly flexible and has a very long throw so it can move large amounts of air (sound waves).

The magnet assembly provides a long magnetic path making it practically impossible for the flux of the voice coil to leave the influence of the magnets which again considerably reduces high level distortions. The tweeter is based on a Titanium diaphragm using flat copper for the voice coil. This maximises efficiency and keeps the weight down. The voice coil frame is Kapton usually reserved for more expensive systems. The crossover occurs at 2.5kHz, well within the range of the bass driver and tweeter. Two inputs, Speakloc in and a linked Speakloc output plus a Jack input. There is a socket in the base for a 35mm pole. The 15A sub bass speaker includes left and right inputs with a direct output linked to the input plus a filtered output which removes a degree of very low frequencies so that the main speakers have a better tonal balance when augmented by the sub bass system. This range will stand direct comparison with models costing double.

This range is highly regarded within the industry and will provide years of service. As a sensible precaution, we stock spare bass drivers and tweeters.

Model	Type	Bass Driver	Freq Resp (-10dB)	Dispersion	Sensitivity	Max SPL	Impedance	Dims H x W x D
10P	2 way w/ passive filter	10" 200W RMS	60Hz - 18kHz	90° x 60°	95dB	120dB	8Ω	530 x 310 x 345mm
12P	2 way w/ passive filter	12" 250W RMS	45Hz - 18kHz	90° x 60°	96dB	121dB	8Ω	630 x 330 x 410mm
15P	2 way w/ passive filter	15" 300W RMS	40Hz - 18kHz	90° x 60°	97dB	122dB	8Ω	720 x 365 x 495mm
15P SUB	Sub Woofer	15" 600W RMS	40Hz - 125Hz	-	98dB	126dB	4Ω	640 x 480 x 500mm
10A	2 way w/ active filter	10" 200W RMS	60Hz - 18kHz	90° x 60°	95dB	120dB	8Ω	530 x 310 x 345mm
12A	2 way w/ active filter	12" 250W RMS	45Hz - 18kHz	90° x 60°	96dB	121dB	8Ω	630 x 330 x 410mm
15A	2 way w/ active filter	15" 300W RMS	40Hz - 18kHz	90° x 60°	97dB	122dB	8Ω	720 x 365 x 495mm
15A SUB	Sub Woofer	15" 300W RMS	40Hz - 125Hz	-	98dB	126dB	8Ω	640 x 480 x 500mm

Description	Weight (kg)	Code	Price (Ex VAT)
10P	13	248-200	£82.50
12P	17	248-210	£99.17
15P	27	248-220	£112.50
15P Sub	28	248-230	£120.83
10A	17	248-240	£157.50
12A	21	248-250	£182.50
15A	25	248-260	£199.17
15A Sub	30	248-270	£212.50
10A/10P Driver	7	248-280	£19.70
12A/12P Driver	8	248-290	£32.40
15A/15P Sub Driver	9	248-300	£37.60
Tweeter	2.7	248-320	£18.40
K&M Eye Bolts	0.1	428-880	£4.65

The Fortissimo range also extends to encompass active models. This series should not be confused with entry level products sold at similar prices which may only include a volume control, nothing else.

Based on the same components as the passive range but with two internal power amps, for the tweeter and the bass driver. The crossover is active so the speakers do not inter react with one another nor are they affected by the inductors and capacitors of a passive crossover.

STUDIOSPARES



Fortissimo 12A Controls

Includes the following controls: XLR in with direct linked XLR output for daisy chaining, a sensitivity switch and gain control for line or mic operation, ground lift, three band EQ, high mid and low, LEDs indicate power on, LF and HF clipping.

DELIVERY BEFORE NOON
no problem

SATURDAY DELIVERY
no problem

DELIVERY BEFORE 10AM
no problem

Studiospares Auditorium 2 Range

Active/Passive PA Speakers

The hugely successful Auditorium range has received a cosmetic update as well as even more efficient drivers and tweeters.

The cone material has benefitted from research in cone resonances resulting in revised bass drivers. Better tweeter power dissipation has resulted in lower temperature rises and greater efficiency. The cabinet dimensions are matched to the bass driver and tweeter performance resulting in a smooth and distortion free sound. The Auditorium range is used in prestigious venues all over the world. Reliability is it's keyword. This is a high end product that will satisfy the most critical users.



212A



2185A



2215A



212MA

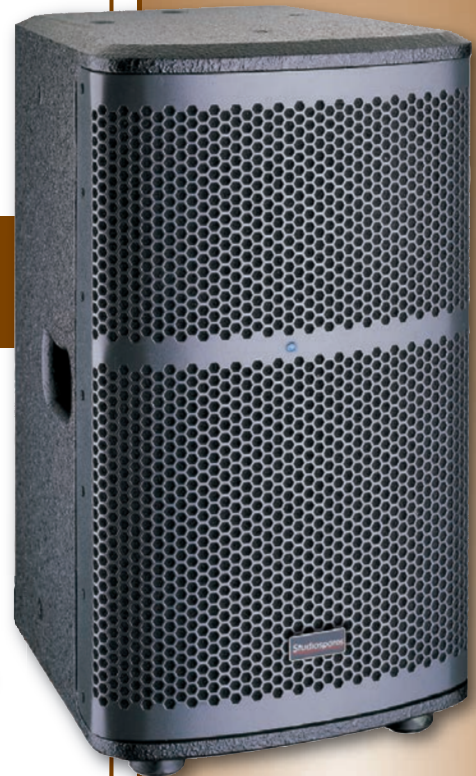

215A

Model	Type	Bass Driver	+ Power	Tweeter	+ Power	Dispersion	Freq Resp(-10dB)	Max SPL	Dims H x W x D	Pole Mounts	Code
208A	8" Active	FG009H-2	150W	FE010	30W	90° x 60°	65Hz - 20kHz	120dB	514 x 300 x 330	underside	248-950
210A	10" Active	FB1016H	300W	K44	40W	90° x 60°	55Hz - 20kHz	124dB	578 x 340 x 350	underside	248-960
212A	12" Active	FB1216H	300W	K44	40W	90° x 60°	45Hz - 20kHz	126dB	660 x 390 x 409	underside	248-970
215A	15" Active	FB1516H	350W	K74	40W	90° x 60°	40Hz - 20kHz	128dB	740 x 424 x 437	underside	248-980
2212A	Dual 12" Active	2x FB1216H	600W	N74	100W	90° x 60°	45Hz - 20kHz	131dB	989 x 405 x 445	none	249-000
2215A	Dual 15" Active	2x FB1516H	600W	N74	100W	90° x 60°	40Hz - 20kHz	132dB	1153 x 450 x 508	none	249-010
212MA	Foldback 12" Active	NA12	300W	C44	50W	90° x 40°	55Hz - 20kHz	126dB	360 x 604 x 335	none	249-020
215MA	Foldback 15" Active	NA15	400W	C44	50W	90° x 40°	50Hz - 20kHz	128dB	415 x 696 x 386	none	249-030
2185A	18" Sub Bass Active	FB1822G	600W	-	-	-	35Hz - 100Hz	128dB	627 x 568 x 710	topside	248-990
208C	8" Passive	FG009H-2	150W	FE010	30W	900 x 600	65Hz - 20kHz	120dB	514 x 300 x 330	underside	248-810
208C Bundle	Includes 208C x2, Stands and Bag										
210C	10" Passive	FB1016H	300W	K44	40W	900 x 600	55Hz - 20kHz	124dB	578 x 340 x 350	underside	248-820
212C	12" Passive	FB1216H	300W	K44	40W	900 x 600	45Hz - 20kHz	126dB	660 x 390 x 409	underside	248-830
215C	15" Passive	FB1516H	350W	K74	40W	900 x 600	40Hz - 20kHz	128dB	740 x 424 x 437	underside	248-840
2212C	Dual 12" Passive	2x FB1216H	600W	N74	100W	900 x 600	45Hz - 20kHz	131dB	989 x 405 x 445	none	248-850
2215C	Dual 15" Passive	2x FB1516H	600W	N74	100W	900 x 600	40Hz - 20kHz	132dB	1153 x 450 x 508	none	248-860
212MC	Foldback 12" Passive	NA12	300W	C44	50W	900 x 400	55Hz - 20kHz	126dB	360 x 604 x 335	none	248-880
215MC	Foldback 15" Passive	NA15	400W	C44	50W	900 x 400	50Hz - 20kHz	128dB	415 x 696 x 386	none	248-890
2185C	18" Sub Bass Passive 8Ω	FB1822H	600W	-	-	-	35Hz - 100Hz	128dB	627 x 568 x 710	topside	248-870
Bracket	Flying Suspension each									M10 x 40mm	248-900

Description	Code	Price (Ex VAT)
208A	248-950	£189.00
210A	248-960	£207.50
212A	248-970	£286.00
215A	248-980	£337.00
2212A	249-000	£396.00
2215A	249-010	£440.00
212MA	249-020	£335.00
215MA	249-030	£387.00
2185A	248-990	£375.00
Bracket	248-900	£3.90

Description	Code	Price (Ex VAT)
208C	248-810	£116.00
208C Bundle	248-815	£207.50
210C	248-820	£158.00
212C	248-830	£199.00
215C	248-840	£216.00
2212C	248-850	£286.00
2215C	248-860	£332.00
212MC	248-880	£204.00
215MC	248-890	£208.00
2185C	248-870	£278.00

Horns can be rotated through 90 degrees for best dispersion and coverage should the speakers be hung horizontally. Bass drivers incorporate huge Neodymium magnets and flat copper wire voice coils wound on Kapton formers which can withstand very high temperatures when run at full power. To avoid burnouts, the Titanium tweeter is protected by an automatic fuse. Substantial M10 flying points allow for suspension by wires from above.

PA Speakers

SPEAKERS

CONTINUED

Behringer Eurolive B1500D Pro

PA Sub-Woofer Speaker

Combines highest performance and versatility in a complete line of professional-grade subwoofers ideally suited for almost any performing situation.

- PA Subwoofer
- 1400-Watt powered drivers, extremely powerful titanium diaphragm compression driver for exceptional high frequency reproduction
- Rotatable, unsymmetrical horn design, ultra-wide frequency range and high sound pressure level



Description	Code	Price (Ex VAT)
Eurolive B1500D-PRO 15" x1	383-110	£290.83

Behringer Eurolive B NEO Series

PA Speakers

The Eurolive NEO Series active loudspeakers are designed to become the new standard in high-quality live sound reproduction.

- Neodymium speakers for superb performance - and 30% less weight
- DSP-Controlled with a 1260-Watt driver
- Integrated Mixer
- Combines low-end punch with high-fidelity definition usually found in much more expensive systems



Description	Code	Price (Ex VAT)
Eurolive B812 Neo x1	383-140	£240.83
Eurolive B815 Neo x1	383-150	£274.17
Eurolive B912 Neo x1	383-130	£240.83

Behringer Eurolive B MP3 Series

PA Speakers

Ideal for both speech and music applications as it is lightweight and powerful, with built-in mixers and custom-designed ransducers.

- 2 connection ports for Behringer Ultralink wireless microphones
- Embedded MP3 player for instant browsing and playing of your music
- Integrated mixer with ultra low-noise, high-headroom mic preamps
- Can take other mic/line signals
- B115MP3 - Wireless active 15" PA speaker
- B112MP3 - 12" PA speaker, with all the same features but with less power and bass response
- B115D/B112D - Same as above, but without the built-in mp3 player



Description	Code	Price (Ex VAT)
Eurolive B115MP3 x1	383-550	£157.50
Eurolive B112MP3 x1	383-560	£149.17
Eurolive B115D x1	383-570	£154.17
Eurolive B112D x1	383-580	£132.50

Behringer Eurolive VP Series

PA Speaker

Revolutionary Class-D amplifier technology and internal switch-mode power supplies, give the VP series an improved power-to-weight ratio compared to many active loudspeakers.

- Powerful dual excursion drivers for bottom end and mid-range
- Wide frequency bandwidth and extensive dynamic range
- Ultra wide 80" x 50" sound dispersion pattern; frequency range 40Hz-22kHz



Description	Code	Price (Ex VAT)
Eurolive VP1220 12"	382-500	£83.32
Eurolive VP1520 15"	382-490	£95.00
Eurolive VP2520 2 x 15"	382-480	£124.17
Eurolive VP1220F Floor 12"	382-510	£79.17
Eurolive VP1800S Sub 18"	382-520	£115.00

Behringer Eurolive B115W/B112W Single

PA System

Active 2-Way PA Speaker System with Bluetooth Wireless Technology and Integrated Mixer.

- 100W PA sound reinforcement
- Bluetooth to stream audio wirelessly
- 2-channel mixer with individual Mic/Line in puts plus 2 band EQ
- Class D amplifier, light weight and reliable
- 1.35" aluminium-diaphragm compression driver.
- 35mm stand mount facility
- Wireless microphone option



Description	Code	Price (Ex VAT)
B115W 15" x1	384-240	£182.50
B112W 12" x1	384-250	£174.17

Behringer Eurolive VS Series

PA Speakers

The VS Series was designed for budget-conscious musicians who demand high quality sound without the high price tag.

- Both the VS1220 and VS1520 produce 650 watts peak (150W RMS) with exceptional sound quality, wide frequency bandwidth and dynamic range
- VS1220 (12") or VS1520 (15") electrodynamic driver
- The VS1220F is a floor monitor version for stage monitoring applications.



Description	Code	Price (Ex VAT)
Eurolive VS1220 12"	382-540	£59.95
Eurolive VS1520 15"	382-530	£74.17
Eurolive VS1220F Floor 12"	382-550	£59.50

Behringer Eurolive F1320D

Active 300w 2-Way Monitor Speaker System



High-power 300-Watt 2-way monitor speaker system for live and playback applications.

This 300-Watt active monitor system has its own 3-band EQ and dedicated volume knob, so you not only have control of the output, but you can tweak the highs, mids and lows for a clear, true sense of your performance. And thanks to the Class-D technology, the F1320D weighs less than 40 lbs (18 kg), making them easy to transport and set up. The built-in adjustable feedback filter helps eliminate annoying squeals and howls so you can crank the volume to a level where you can actually hear yourself above the raging chaos, otherwise known as your band. The F1320D helps you hear yourself better so you can perform up to your true potential.

Description	Code	Price (Ex VAT)
Eurolive F1320D	382-890	£140.00

Behringer Eurolive B1200D-Pro Single

Sub Woofer

Featuring a 500 watt class D amplifier this model includes some useful features.

- Class D digital amp saves weight and heat
- Built in active high pass stereo crossover
- Tunable and switchable bass boost
- Phase switch to avoid phase cancellations
- Status LEDs for Signal, Clip and Power
- 12" long excursion transducer



Description	Code	Price (Ex VAT)
B1200D-PRO	383-920	£172.50

Behringer Eurolive B1520 PRO

PA Speaker

The B1520 PRO loudspeaker is geared towards professional applications.

- 800W 15inch loudspeaker intended for PA applications
- 10 & 35 degree cluster and stacking mode
- Stand mounting with 35mm pole socket or positioning as a floor monitor wedge
- Frequency range 50Hz - 18kHz
- Proprietary 13/4" titanium diaphragm compression
- Built-in overload-protection circuitry



Behringer Eurolive B1800X Pro

PA Speaker

If you want to add amazing low-end punch to your sound, then look no further.

- 1600W 18inch subwoofer with an amazing price-to-performance ratio
- Built-in switchable crossover allows for optional passive or bi-amping operation
- Frequency range 40 - 300 Hz
- 100 dB half space 1W @ 1m



Description	Code	Price (Ex VAT)
B1520 Pro x1	380-920	£165.00
B1800X Pro x1	380-940	£212.50

FREE catalogue
 Are you reading someone else's catalogue? Why not call us and order your own copy...
it's free!

Behringer Eurolive D Series PA Speakers

Multi-purpose active speakers for vocal and keyboard monitoring, multimedia and home recording studios.

As a result of Behringer's Class-D amplifier technology and internal switch mode power supplies, the EUROlive D Series loudspeakers provide a much better power to weight ratio than competing active speakers. The integrated sound processor provides total system control, along with dependable protection of the LF and HF transducers, thanks to the built in active high pass filter, which virtually eliminates distortion even at extreme operating levels. There are 5 versions available. The B205D is a 150W active speaker, the 550W B215D has a 15" Woofer, the 550W B212D has a 12" Woofer, the 220W B210D has a 10" Woofer and the 220-Watt B208D has a 8" Woofer. The latter four versions feature an Ultra-Low Noise (ULN) Mic/Line input with LEVEL control and a dedicated 2-band EQ (bass/treble) for easy control.



Description	Code	Price (Ex VAT)
Eurolive B215D 15" x1	382-440	£172.50
Eurolive B215D 15" White x1	382-445	£195.00
Eurolive B215D x2 + Stands/Bag + X1222USB + Leads	382-441	£495.83
Eurolive B215D x2 + Stands/Bag	382-442	£362.50
Eurolive B212D 12" x1	382-450	£137.50
Eurolive B212D 12" White x1	382-455	£174.17
Eurolive B210D 10" x1	382-460	£112.50
Eurolive B210D 10" White x1	382-465	£132.50
Eurolive B210D x2 + Stands/Bag	382-462	£237.50
Eurolive B208D 8" x1	382-470	£102.50
Eurolive B208D 8" White x1	382-475	£112.50
Eurolive B205D x1	383-180	£113.33
Eurolive B205D x2 + Stands/Bag	383-182	£237.50



Behringer Eurolive XL Series

2-Way PA Speakers

Upgrades the original B215/B212 with the same bass and treble/mid transducers for even better sound and power handling.

- 250W Continuous power 170W RMS
- 1.75" titanium-diaphragm compression driver with overload protection
- Wide dispersion exponential horn
- 35-mm pole socket



Description	Code	Price (Ex VAT)
Eurolive B215XL	381-920	£109.00
Eurolive B215XL-WH	382-240	£119.00
Eurolive B212XL	381-930	£87.50
Eurolive B212XL-WH	381-940	£97.50

Behringer Eurolive B612D/B615D Single PA Speaker

Features an integrated sound processor for total system control and dependable protection of the LF/HF transducers.

- High-power 1500W 2-way PA sound reinforcement speaker system
- Ultra-compact and light weight system
- Internal switch-mode power supply
- Powerful 12" excursion driver
- B615D as the B612D, but with a 15" driver for even more bass response



Description	Code	Price (Ex VAT)
B612D	383-530	£224.17
B615D	383-540	£240.83

Behringer Eurolive B1220/B2520 Pro PA Speaker

Engineered to handle the demands of professional gigs, from small clubs to large stages.

- Ultra-wide 50 Hz – 18 kHz frequency range
- Overload-protection circuitry ensures optimal HF driver protection
- Brilliant, natural high frequency reproduction
- B1220 - 800W 12" loudspeaker
- B2520 - 15" passive full-range PA Speaker



Description	Code	Price (Ex VAT)
B1220 Pro x1	380-930	£145.00
B2520 Pro x1	383-330	£207.50

Turbosound Milan M10/M12 Single Powered PA Speaker

Powered PA Speaker

Optimum performance and long term reliability.

- 2 way full range powered loudspeaker
- KLARK TEKNIK Class-D technology
- High excursion low frequency driver
- 1" high temperature dome compression driver
- Switchable 100 Hz high pass filter for subwoofer integration
- Lightweight composite enclosure with black finish
- Rugged powder coated perforated steel mesh grille
- The **M10** features 600 Watt power with a 10" driver, and the **M12** has a 1,100 Watt power and a 12" driver



Behringer Eurolive B207MP3 Single 150W Active Speaker System

Includes MP3 player.

Includes MP3 player.

- 6.5" full range driver
- Low noise 4-channel mixer with 3-band EQ
- 3 Mic Preamps with phantom powering
- 1 instrument-ready input (no DI required)
- Stereo input for keyboards, MP3, etc



Description	Code	Price (Ex VAT)
B207MP3	383-930	£140.83

Behringer Eurolive F1220A Active 150W Floor Monitor Speaker System

Provides a sonically sophisticated solution for live and playback on small to medium stages.

Behringer Eurolive F1220A is a powerful 12", long excursion low frequency driver for abundant bass punch and accurate low midrange. It is also a high resolution 1" HF driver for clarity and brilliance with a groundbreaking horn design, ensuring smooth frequency response and ultra wide sound dispersion so you can move around the stage.



Description	Code	Price (Ex VAT)
F1220A	382-230	£115.83



PRICE match
 Studiospares will BEAT any genuine price from any UK competitor on any item or order.
details on page 318

SPEAKERS

PA Speakers

CONTINUED

Mackie Thump

Powered Speaker

Designed by the same team that produced the SRM450v2, the Thump Powered Loudspeakers deliver deep low-end and real power in a lightweight design that is extremely portable.



- Mackie Active processing.
- Precision crossover and driver time-alignment for system efficiency
- 3-band EQ for tone control
- Pole-mounted or used as a wedge
- Great value for money

Description	Code	Price (Ex VAT)
Thump 12 x 1	262-670	£220.83
Thump 12 Pair + Bundle	262-671	£457.50
Thump 15 x 1	262-680	£249.17
Thump 15 Pair + Bundle	262-681	£515.00
Thump 185 x1 Sub	262-690	£482.50

Mackie S Series

PA Speakers

Designed to provide all the power and performance required for a modern PA system.



- Class-leading power handling for professional shows
- Precision, high-output transducers
- S512 - 250W RMS, 500W program and 1000W peak performance
- S515 - 300W RMS, 600W program and 1200W peak performance
- S515 - 600W RMS, 1200W program and 2400W peak performance

Description	Code	Price (Ex VAT)
S512 12"	262-490	£242.50
S515 15"	262-500	£256.67
S525 2x15"	262-510	£381.67
S5185 Passive Subwoofer	262-520	£340.83

Mackie SRM450 V3

12" PA Speakers

The most widely used portable speakers ever!

The all-new SRM450s deliver the unparalleled ease-of-use, professional sound quality and indestructible portability that made SRM a live sound legend. Now packed with 1000W of power, the widest selection of truly useful sound-enhancing DSP and setup-friendly audio tools, SRM is ready for your high-output application. SRMs feature modern tools like application-specific speaker modes and an automatic feedback destroyer, each with a single-button interface that gets you optimized performance in just seconds. And with the integrated 2-channel mixer, you can easily mix multiple sources. Only SRMs deliver this level of power and sound quality in such an indestructible, portable package.

The bundle includes SRM450, 2 x 10m XLR Leads, 2 PA metal speaker stands and a Tuff speaker stand bag.

Description	Code	Price (Ex VAT)
SRM450 V3 x1	262-710	£332.50
SRM450 V3 x2	262-712	£665.00
SRM450 V3 Bundle	262-715	£665.83
SRM450 V3 x2 + SRM1801 Sub	262-716	£1165.83
SRM450 V3 x2 + Fortissimo 15A Sub	262-717	£832.50



MACKIE

Mackie SRM350 V3

PA Speaker

Brings studio-monitor sound quality to a world inundated with big, inefficient PA speakers.



- 1000W System Power
- 10" high-output LF Driver
- High definition Audio Processing
- Integrated 2 channel mixer
- The Bundle package includes a pair of SRM350s, a pair of stands, bag and 2 x XLR Leads

Description	Code	Price (Ex VAT)
SRM350 V3 x1	262-700	£290.83
SRM350 V3 x2	262-702	£581.67
SRM350 V3 Bundle Package	262-705	£582.50

Mackie SRM150 Single

PA Speaker



The built-in three-channel mixer features two combo XLR/line inputs (with true 48V phantom power), a stereo channel for CD/MP3 players and Mackie's powerful 3-band Active EQ. The SRM150 can be mounted on a mic stand, making it the ideal personal monitor. Put simply, with its tremendous feature set and 150-watts of world-class sound, the Mackie SRM150 is the perfect solution for any application requiring superior sound quality. At the very heart of the SRM150 is a Mackie mixer, with all the versatility and features you've come to expect from the manufacturer of the world's best selling compact mixers. Channels 1 and 2 can be used for mic/line sources, thanks to the handy Neutrik Combo Jack, which accepts either TRS or XLR connections. True 48V phantom power is supplied, so condenser mics can be used with confidence. Simply plug in your guitar, bass (or any other Hi-Z instrument), press the CH1 Instrument switch and you get all the benefits of a DI box, without the hassle and added expense.

Description	Code	Price (Ex VAT)
SRM150	261-990	£207.50
SRM150 Bag	261-995	£47.50

Mackie SRM550/SRM650 Pair

PA Speaker

Mackie speakers have a reputation for raw power and unmatched durability, and these SRM550s are no exception.

1600 Watts of system power, paired with custom transducers, deliver gig-level volumes without breaking a sweat, and the speakers are front ported for maximum low-end extension and punch. A 12"/15" high-output LF driver and 1.4" titanium dome compression driver produce vibrant, vivacious sound, while patented acoustic correction developed with touring geniuses at EAW® brings the performance up another level. With integrated two-channel mixers and one-button automatic feedback destroyers, these are highly capable speakers, breathtakingly loud and technically superb at the very same time.

The Bundle package includes a pair of SRM550s or SRM650s, a pair of stands, bag and 2 x XLR Leads.

Description	Code	Price (Ex VAT)
SRM550 12" Pair	262-590	£831.67
SRM550 12" Bundle Package	262-595	£832.50
SRM650 15" Pair	262-600	£998.33
SRM650 15" Bundle Package	262-605	£999.17
SRM1850 Subwoofer	262-610	£582.50

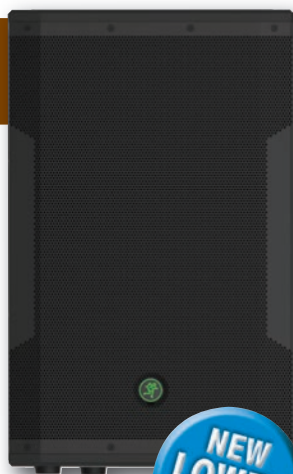

MACKIE

WANT a job?

Are you looking for a stable and rewarding career?

Studiospares are constantly expanding. We require additional staff for a variety of positions, working in a very congenial atmosphere. Practical experience of recording and/or live sound engineering would be preferable.

send in your CV in the first instance

Electro-Voice ZX4

15" 2-Way Loudspeaker

A "Road Ready" product that give good account of itself anywhere.

- 15" Long throw woofer. 1.25" titanium HF
- Maximum SPL 132dB. 90° x 50° coverage
- Max power: 400 W continuous, 1600 W peak
- Wedge shape for monitors at 45° or 55
- Freq Response (-10 dB) 42 - 20000 Hz
- Inputs via NL4 Speakons



Description	Code	Price (Ex VAT)
ZX4	414-210	£415.83

Electro-Voice ZX1i

Indoor/Outdoor Installation Speaker

The ZX1i features full overload protection for reliable, long term operation.

- EV8L high performance weatherized 8" woofer
- DH2005 1" true compression driver
- Weatherized multi layer grille
- Rotatable waveguide allows for speaker orientation
- Low loss crossover network
- Frequency Response 60 Hz - 20 Hz
- Full system overload protection circuitry
- High capacity 100w transformer
- "Click n' Mount" QuickSAM™ mounting system



Description	Code	Price (Ex VAT)
ZX1i	414-230	£329.15

Electro-Voice Live-X ELX115/ELX112

2-Way Passive Loudspeakers

Pro-quality audio for sound reinforcement, PA, and stage monitoring applications.

- 250W continuous (1000W peak) power handling capability to provide a strong, distortion-free performance
- A pair of NL4 Speakon connectors
- 1.5" titanium compression driver provide crisp, natural audio with a wide frequency response.



Electro-Voice Live-X ELX118

Passive Subwoofer

Makes the ideal addition to the ELX-series of satellite speakers for reinforcing low frequency performance. High sound pressure levels (max 134 dB). A single 18" LF driver.

Description	Code	Price (Ex VAT)
ELX112 Passive 12" x1	414-130	£249.17
ELX115 Passive 15" x1	414-140	£315.83
ELX118 Sub-woofer 18" x1	414-160	£299.00
ELX112 12" x2 + Stands + Bag	414-132	£450.00
ELX115 15" x2 + Stands + Bag	414-142	£610.00

Electro-Voice Live X ELX115P/112P

2-Way Powered Loudspeakers

Offer pro-quality audio for sound reinforcement, PA, and stage monitoring applications.

Clear, powerful, and musical, the Live X series was born to command the stage for professional music performance. Designed for a wide range of portable sound applications, Live X loudspeakers are housed in hardy stackable enclosures of solid wood, making them lighter than comparable-quality composite or plastic boxes and therefore easier to load, transport, and set up. With high output, extended frequency range, and high sensitivity, Live X loudspeakers are clean, flat, and hot, making music of all kinds sound its best. The Live X series is serious gear for serious sound. 1000W Class-D amplifier provides a strong, distortion-free performance. Plywood cabinet can be placed vertically or horizontally for PA or stage monitoring. Features a pair of XLR/TRS combo inputs, a stereo RCA input, and an XLR link output. 1.5" titanium compression driver provide crisp, natural audio.



Electro-Voice Live X ELX118P

Powered Sub Woofer

An ideal companion for full-range loudspeakers such as the ELX112P and ELX115P.

18" woofer provides bass frequencies as low as 32Hz. 700W Class-D amplifier provides a strong, distortion-free performance. XLR/TRS combo input and an XLR link output connectors.

Power handling: 400 W continuous, 1600W peak. Braced 15mm plywood enclosure. Stack or pole-mount full-range boxes. Black textured finish.



Description	Code	Price (Ex VAT)
ELX112P Powered 12" x1	414-100	£399.00
ELX115P Powered 12" x1	414-110	£540.83
ELX118P Sub-woofer 18" x1	414-120	£607.50

Bundles

Description	Code	Price (Ex VAT)
ELX112P 12" Powered Pair + Stands + Bag	414-102	£850.00
ELX115P 15" Powered Pair + Stands + Bag	414-112	£1055.00



EV Electro-Voice

PRICE changes

This catalogue was priced on 1st December 2014.

Current prices may be higher...

see our website for up to date prices.

Electro-Voice ZLX-12P/ZLX-15P

Active PA Speakers

12" woofer and 1.5" high-frequency titanium compression driver.

- Response 50 Hz - 20 kHz
- LCD display and unique single-knob DSP control with presets. Max SPL 126dB
- Input level meters and independent amplifier control ensure optimal gain structure
- Custom-built 1000-W Class-D amplifier
- Hi/lo grip design for effortless pole mounting
- ZLX-15P - same spec aside from Bass unit 15", Response 42 Hz - 20 kHz. Max SPL 127 dB



Description	Code	Price (Ex VAT)
ZLX-12P Active x1	414-170	£274.17
ZLX-12P Speaker Cover x1	414-171	£39.20
ZLX-15P Active x1	414-180	£340.83
ZLX-15P Speaker Cover x1	414-181	£39.20
ZLX-12P x2 + Stands + Bag	414-172	£538.00
ZLX-15P x2 + Stands + Bag	414-182	£658.00

Electro-Voice ZLX-12/ZLX-15

Passive PA Speakers

12" woofer and 1.5" high-frequency titanium compression driver.

- Response 55 Hz - 20 kHz
- Power 250 W continuous and 1000 W peak power handling.
- Max SPL 95dB
- ZLX-15 - same spec aside from 15" woofer and 1.5" high-frequency titanium compression driver; Response 44 Hz - 20 kHz; Power 250 W continuous and 1000 W peak power handling. Max SPL 96dB



Description	Code	Price (Ex VAT)
ZLX-12 Passive x1	414-190	£205.00
ZLX-15 Passive x1	414-200	£332.50
ZLX-12 x2 + Stands + Bag	414-192	£390.00
ZLX-15 x2 + Stands + Bag	414-202	£638.00

MORE PRODUCTS online

ALL PRICES EXCLUSIVE OF VAT.

SPEAKERS

PA Speakers

CONTINUED

LIVE Series

PA Speakers

A new range of PA speakers incorporating the very latest in driver technology. Substantial Ferrite magnets with high temperature voice coils provide a massive amount of power.

- 12" L12 150 watts RMS (300 watts peak)
- 15" L15 200 watts RMS (400 watts peak)
- A proven Piezo Tweeter maintains crisp high end frequencies
- Impedance 8Ω. Frequency response 60Hz - 18kHz
- Jack inputs. Reinforced corners, metal grille.
- Cabinet finished in a special industrial material which resists abrasion.



These speakers are sold at a fraction of the cost of the same product which is sold under a big brand name. Imported directly from the factory by the container load.

Description	Code	Price (Ex VAT)
L12 12"	249-220	£40.42
L12 12" Pair	249-222	£74.16
L15 15"	249-230	£55.00
L15 15" Pair	249-232	£104.16
Live SUB	249-260	£49.17

LIVE Packs

Description	Code	Price (Ex VAT)
L12 Pack A - 2 x L12 + Stands + Bag	249-225	£120.83
L12 Pack B - 2 x L12 + Stands + Bag + Trojan 200 Amplifier + Leads	249-226	£237.50
L15 Pack A - 2 x L15 + Stands + Bag	249-235	£149.16
L15 Pack B - 2 x L15 + Stands + Bag + Trojan 600 Amplifier + Leads	249-236	£287.50



Behringer VQ1800D/VQ1500D

NEW LOWER PRICE

Sub-Woofer

Active 500-Watt 18" PA Subwoofer with Built-In Stereo Crossover.

- 500-Watt Class-D amplifier with thermal and clip limit protection
- Built-in active stereo crossover provides high-pass filtered for full-range loudspeakers
- Tunable and switchable Bass Boost
- VQ1500D - The only difference is the speaker is 15". 500 watts power is the same



Description	Code	Price (Ex VAT)
VQ1800D 18"	384-260	£249.17
VQ1500D 15"	384-270	£207.50

Behringer MPA40BT Europort

NEW LOWER PRICE

PA Speaker

All-in-One Portable PA System with Full Bluetooth Connectivity.

- 40 watts output from mains or battery
- High-quality dynamic microphone included
- Up to 12 hours battery life
- 2 mic inputs with dedicated gain controls
- Aux input for CD, MP3 players etc 2 band EQ
- Wireless ready facility. Pole mount in base
- Speakers, 8" bass driver and a tweeter
- MPA40BT - This version is without a retractable handle and wheels



Description	Code	Price (Ex VAT)
MPA40BT	384-290	£115.83
MPA40BT-PRO	384-280	£124.17

Behringer Europort EPS500MP3

PA Speaker

Compact 500-Watt 8-Channel Portable PA System with MP3 Player, Reverb and Wireless Option.

- Dual speakers and detachable 500 Watt powered mixer
- Mixer can be used attached or detached
- 8" woofers & 1" compression transducers
- 8-channel mixer section features 4 mic/line and 2 stereo channels. Mic amps inc phantom
- Musical 2-band EQ on all channels



Description	Code	Price (Ex VAT)
EPS500MP3	383-970	£249.17

Galaxy Hotspot PA-6S

2-Way Speaker System

Ultra high power one-piece PA system/powerd monitor.

- 2-Way Speaker System
- 6.5" Neodymium Woofer
- 1.5" Titanium Dome Tweeter
- 170 Watt Amplifier
- 3 Inputs (2-XLR/1/4" Combos, One 1/8")
- Mounts to Any Mic Stand
- Integrated Handle, Mounting Points for Mic Boom & Bracket
- Built In Compressor/Limiter
- XLR Pass Thru On Channels 1 & 2



Description	Code	Price (Ex VAT)
PA-6S	223-800	£249.99

Mackie DLM8/DLM12

PA Speaker

Compact and Lightweight 2000W Active PA Speakers.

The Mackie DLM8/DLM12 are 2000W Class D active speakers and part of the DLM Series. They combine unique driver design with powerful proprietary digital signal processing - delivering unprecedented performance in a ultra-compact system. They feature TruSource Technology, an innovative concept that combines a 1.75" high-frequency compression driver with 8" low-frequency woofer into a single, vertically-aligned, common-magnet driver. Enabling the unit to be compact, light-weight and extremely capable, delivering unmatched fidelity across the entire frequency range. Driving the DLM8/DLM12 is a 2000W, Class-D, ultra-efficient amplifier that provides maximum power in a minimal space with plenty of headroom to be heard. The power-pack features optimum heat dispersion and dynamic protection circuitry to keep things running smoothly night after night.

Drawing on years of mixer experience, Mackie have incorporated a powerful one-touch integrated digital mixer with all the connectivity, effects, processing and tools needed for professional applications.

Description	Code	Price (Ex VAT)
DLM8 8" x1	262-560	£555.00
DLM8 8" x2 + Stands + Leads	262-561	£1129.00
DLM8 8" x2 + DLM125 + Stands + Leads	262-562	£1825.00
DLM12 12" x1	262-570	£624.00
DLM12 12" x2 + Stands + Leads	262-571	£1268.00
DLM12 12" x2 + DLM125 + Stands + Leads	262-572	£1990.00
DLM125 Sub Woofer x1	262-580	£798.00



DLM125

MACKIE.

SPEAKERS

PA Speaker Accessories

Studiospares Speaker Chassis

This range of speaker accessories are those used in our own products and have proven themselves to be 100% reliable.

- You are purchasing directly from the importer so reducing at least one step in the supply chain and hence the cost
- Bass drivers us huge Neodymium magnets. Most have cast aluminium chassis for maximum stability.
- Tweeters are ferro fluid cooled.



	Freq Range	Sensitivity 1W@1M	Impedance Ω	Order Code	
18" Sub Woofer FA2241G Die cast Frame (Auditorium 118Sub)					
600 pink	30-3kHz	98dB	4Ω	248-630	
600 pink	30-3kHz	98dB	8Ω	248-790	
15" Sub Woofer FA2226H Die cast Frame (Auditorium 215B)					
600 pink	30-2.5kHz	95dB	8Ω	248-490	
15" Sub Concentric Woofer FA2226C Die cast Frame (Audi215MB)					
600 pink	30-2.5kHz	95dB	8Ω	248-510	
12" Woofer FA2206H Die cast (Auditorium 212B)					
600 pink	50-2kHz	95dB	5Ω	248-480	
15" Woofer FB1503H Pressed Steel (Fortissimo 15P + 15A)					
350 pink	40-4.5kHz	97dB	8Ω	248-300	
12" Woofer FB1203H Pressed Steel (Fortissimo 12P + 12A)					
250 pink	45-5kHz	96dB	8Ω	248-290	
10" Woofer FB1003H Pressed Steel (Fortissimo 10P + 10A)					
200 pink	50-5.5kHz	95dB	8Ω	248-280	
6.5" Mid Range FG010H-2 Pressed Steel (Auditorium 315B)					
80 RMS	97-5.5kHz	90dB	8Ω	248-500	
Tweeter FE010 (All Auditorium speakers with tweeters)					
80 RMS	800-20kHz	107dB	8Ω	248-640	
Tweeter Voice Coil only FE010					
				248-690	
8" Bass Driver FG009H-2					
150 RMS	57Hz-8kHz	96dB	8Ω	249-040	
10" Bass Driver FB1016H Auditorium 2 series Model 208A/C					
250 RMS	55Hz-6kHz	97dB	8Ω	249-050	
12" Bass Driver FB1216H Auditorium 2 series Model 210A/C					
300 RMS	45Hz-6kHz	97dB	8Ω	249-060	
15" Bass Driver FB1516H Auditorium 2 series Model 215A/C					
350 RMS	34Hz-5kHz	98dB	8Ω	249-070	
18" Bass Driver FB1822G Auditorium 2 series Model 2185A					
700 RMS	31Hz-2kHz	97dB	4Ω	249-080	
18" Bass Driver FB1822H Auditorium 2 series Model 2185C					
700 RMS	31Hz-2kHz	97dB	8Ω	249-085	
Compression Driver N74 Auditorium 2212/2215 A/C					
100 RMS	500Hz-20k	110dB	8Ω	249-130	
Compression Driver C44 Auditorium 212MC/215MC					
40 RMS	800Hz-18k	108dB	8Ω	249-110	
12" Bass Driver NA12 Neodymium Auditorium 212MC/212MA					
300 RMS	45Hz-3.5k	97dB	8Ω	249-095	
15" Bass Driver NA15 Neodymium Auditorium 215MC/215MA					
400 RMS	42Hz-3kHz	98dB	8Ω	249-090	

Description	Code	Price (Ex VAT)
18" Sub 4Ω	248-630	£74.50
18" Sub 8Ω	248-790	£72.40
15" Sub 215B	248-490	£98.60
15" Sub 215MB	248-510	£78.23
12" Woofer 212MB	248-480	£49.70
15" Woofer	248-300	£37.60
12" Woofer 12P + 12A	248-290	£32.40
10" Woofer	248-280	£19.70
6.5" Midrange	248-500	£29.50
FE010 Tweeter	248-640	£56.40
FE010 Voice Coil	248-690	£16.20
8" Bass Driver	249-040	£22.40
10" Bass Driver	249-050	£38.30
12" Bass Driver	249-060	£47.80
15" Bass Driver	249-070	£62.50
18" Bass Driver for 2185A	249-080	£148.00
18" Bass Driver for 2185C	249-085	£147.00
N74 Compression Driver	249-130	£94.40
C44 Compression Driver	249-110	£63.70
12" Bass Driver for 212MC/MA	249-095	£125.00
15" Bass Driver for 215MC/MA	249-090	£147.00

Auralex Great Gramma
Speaker Support

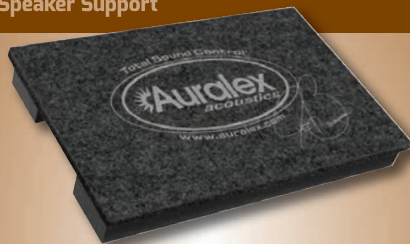

Great GRAMMA is an ideal option for performing musicians and studio engineers.

Great GRAMMA is built on the success of GRAMMA. It stops that uncontrollable rumble where your amp vibrates with the floor, giving you a clearer tone and better quality. It is 30" long x 19" wide x 2.75" high and weighs 300lbs

Description	Code	Price (Ex VAT)
Great GRAMMA	461-940	£68.30

Auralex Gramma

Amp/Monitor Support

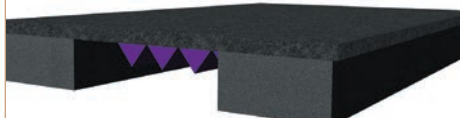

The GRAMMA from Auralex is an incredibly effective device that's used to float an amp or loudspeaker and yields nearly total acoustic isolation, resulting in a purity of tone that has to be heard to be believed. GRAMMA comes complete with a carrying handle, road-ready carpet, Studiofoam wedges (underneath) and Platfoam. Dimensions 58cm long x 38cm wide x 7cm high, meaning that 1 or 2 GRAMMAS will support nearly all amps, speaker cabinets, subwoofers, and monitors.

Description	Code	Price (Ex VAT)
Gramma	461-180	£38.20

Studiospares Crossover Units

One of the major components of the Auditorium series speakers. Aside from being used as replacements they are a problem solver for anyone building their own system.

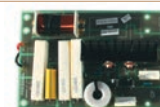

	Ways	X over Freq	Impedance Ω	Power	Order Code
2215B	2 Way	2.2kHz	4Ω	1200	248-740
212B	2 Way	2.2kHz	8Ω	600	248-700
215B	2 Way	2.2kHz	8Ω	600	248-710
312B	3 Way	800Hz + 4kHz	8Ω	600	248-720
315B	3 Way	800Hz + 4kHz	8Ω	600	248-730
212MB	2 Way		8Ω	600	248-750
215MB	2 Way		8Ω	400	248-760

Description	Code	Price (Ex VAT)
2215B	248-740	£35.42
212B	248-700	£31.67
215B	248-710	£31.67
312B	248-720	£22.00
315B	248-730	£33.25
212MB	248-750	£31.67
215MB	248-760	£22.00

Studiospares HF Driver/Tweeter Horns

All current Auditorium speakers have a common HF driver, the FE010 chosen for its outstanding performance and absolute reliability. Coupled to the driver are a series of horns all of which attach to the FE010 with screws. For cross reference purposes we have listed just one of the Auditorium models the horns are used in.



	Dispersion Angle	Cut off Freq Hz	Lowest Xover Freq	Order Code	
FD018 Horn (Auditorium 2215B)					
2215B	60° x 40°	500Hz	800Hz	248-650	
FD014 Horn (Auditorium 315B)					
315B	90° x 40°	500Hz	800Hz	248-660	
FD009 Horn (Auditorium 215B)					
215B	90° x 50°	450Hz	500Hz	248-670	

Description	Code	Price (Ex VAT)
FD018 Horn	248-650	£9.20
FD014 Horn	248-660	£7.20
FD009 Horn	248-670	£13.20

Behringer WB208/WB210

Speaker Bracket

The Behringer Eurolive WB208, Black is a wall mount bracket for Eurolive B208 series speakers.

- Ideal for installation in theaters, churches, restaurants, etc.
- Built-in swivel lets you aim the loudspeaker across a wide 180° axis
- WB210 is for use with the Eurolive B210 series speakers, black colour.



Description	Code	Price (Ex VAT)
WB208 x1	383-340	£24.99
WB210 x1	383-350	£24.99

MORE PRODUCTS
online

SPEAKERS

PA Speaker Accessories

CONTINUED

Monacor CP-5/SW

PA Terminal

Terminals for building PA speaker systems and for general use.

Metal recessed mounting plate with two pre-drilled socket holes for speaker panel mount or chassis mount input sockets. Robust steel version. Black lacquered.

For 2 x Speakon, without connectors.



Description	Code	Price (Ex VAT)
CP-5/SW	258-390	£5.70

Monacor MZF-8688

Speaker Screw Set

- M8 x 40mm
- 8 pieces



Monacor MZF-8605

Speaker Screw Set

- M5 x 40mm
- 8 pieces



Monacor MZF-8604

Speaker Screw Set

- M4 x 40mm
- 8 pieces

Description	Code	Price (Ex VAT)
MZF-8688 M8x8	258-280	£6.25
MZF-8605 M5x8	258-290	£3.35
MZF-8604 M4x8	258-300	£3.35

Monacor HF-145/140

Rubber Foot

- HF-145 38mm dia x20mm high
- HF-140 38mm dia x10mm high



Description	Code	Price (Ex VAT)
HF-145 38x20mm	258-340	£1.65
HF-140 38x10mm	258-350	£1.55

Monacor ST-400/GM

Bi-Wiring Terminal

- With gold-plated all-metal connectors
- For screwing as well as for 4 mm banana plugs



Description	Code	Price (Ex VAT)
ST-400/GM	258-380	£15.70

Adjustable Speaker Spikes x4

Set of 4 pieces.

- Slim version
- Adjustable in height
- With support disks and drive-in nuts
- Gold-plated (GO) or black chromium-plated



Description	Code	Price (Ex VAT)
Gold	258-310	£14.95
Black	258-320	£13.75

Monacor Acoustic Foam Front Sheets

Anthracite-coloured, open-cell foam (10 mm thick).

- High sound transparency
- Various dimensions
- Matching the corresponding MZF grilles
- Supplied in pairs

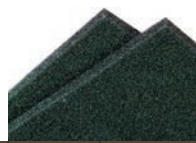

Description	Code	Price (Ex VAT)
611x480mm x2	258-200	£14.70
668x579mm x2	258-210	£22.30
780x422mm x2	258-220	£17.60
480x378mm x2	258-230	£11.30

Monacor MZF-8625

Grille Fixing Clamp

- 20mm x 38mm
- Hole size 7 x 11mm



Monacor MZF-8624

Grille Fixing Clamp

- 14mm x 38mm
- Hole size 7 x 11mm



Description	Code	Price (Ex VAT)
MZF-8625	258-250	£1.55
MZF-8624	258-260	£1.55

Monacor MZF-40

Speaker Clamps Set of 4

For PA speakers of all sizes.

- Elongated hole for M6
- Durable plastic
- Set of 4
- Drill hole size: 6 x 16 mm



Description	Code	Price (Ex VAT)
MZF-40	258-270	£4.95

Monacor MZF-8305/8304

Recessed Handle

- Large - 162x280x69 mm
- Medium - 162x220x56 mm



Description	Code	Price (Ex VAT)
Large	258-360	£12.80
Medium	258-370	£10.60

Speaker Foam Mounting/Sealing Tape

5 x 150cm

Ideally suited for speaker mounting.

- Dimensions mm 1500 long x 5 wide x 2 thick
- 5 pieces



Description	Code	Price (Ex VAT)
Foam mounting/Sealing tape	256-970	£8.32

Speaker Grille

Classic shape with square perforation.

- Rubber rim
- Black lacquered
- To be fixed with clamps
- High stability in all sizes

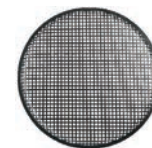

Description	Code	Price (Ex VAT)
Grille 3"	258-130	£4.99
Grille 4"	258-140	£6.75
Grille 5"	258-150	£8.35
Grille 6.5"	258-160	£9.85
Grille 8"	258-170	£12.30
Grille 10"	258-180	£16.30
Grille 12"	258-190	£19.90

Monacor Acoustic Foam Front Sheets

Anthracite-coloured, open-cell foam (10 mm thick).

- High sound transparency
- Various dimensions
- Matching the corresponding MZF grilles
- Supplied in pairs

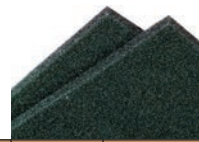

Description	Code	Price (Ex VAT)
611x480mm x2	258-200	£14.70
668x579mm x2	258-210	£22.30
780x422mm x2	258-220	£17.60
480x378mm x2	258-230	£11.30

Acoustic Grille Cloth

Black textile fabric for covering the front of speaker systems and sound boards.

- Very good sound transparency
- Dimensions: 1400 x 750 mm, stretchable
- Colour Black



Description	Code	Price (Ex VAT)
140x75mm Black	258-240	£15.80

PDF catalogue

Want this catalogue on your phone or laptop?

The Studiospares catalogue is now available in PDF format.

visit www.studiospares.com/page/pdfcatalogue!

SPEAKERS

Resonance Absorbers x4

Black/Gold

Effectively suppresses the transmission of unwanted vibrations.

- With gold-coloured decorative ring
- 25mm x 20mm
- Maximum load/set: 30 kg
- Supplied with adhesive pads
- Fixed selling quantity: 4 pieces



Description	Code	Price (Ex VAT)
Resonance Absorbers x4	258-330	£12.70

Speaker Felt Bituminous x6

495 x 330mm

For reducing the impact sound of surfaces which easily vibrate, e.g. walls of speaker cabinets and car body parts.

- Highly dampening and highly flexible bituminous-elastomer compound
- Sheets are self-adhesive on one side
- Self-extinguishing acc. to DIN 75200 (FMVSS 302)
- Dimensions of each sheet: 495x330 mm



Description	Code	Price (Ex VAT)
Felt Bituminous x6	258-010	£37.50

Speaker Sealing Tape

3m Tape

Placed between the cabinet and speaker to provide an airtight seal.

- 3 metres of elastic tape



Description	Code	Price (Ex VAT)
Sealing Tape	256-940	£16.25

Speaker Foam Sealing Tape

20m Grey

For hidden applications in do-it-yourself speaker building concepts.

- 20 m of self-adhesive sealing tape
- Dimensions 20mm wide x 2 mm thick

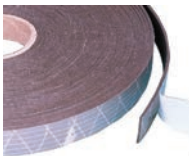

Description	Code	Price (Ex VAT)
Foam Sealing Tape	256-950	£12.49

Speaker Sealing Tape Rubber

10m Black Tape

For visible applications in do-it-yourself speaker building concepts, e.g. as an underlay for metal front grilles.

- Roll 10 m long
- 20mm wide x 2mm thick
- Jet-black rubber foam.
- Highly flexible, permanently elastic



Description	Code	Price (Ex VAT)
Sealing Tape Rubber	256-960	£16.25

Speaker Bags

Durable padded fabric carry bags for most 10", 12" and 15" speakers.

- The loudspeaker can be used while the case is still fitted offering limited protection against the elements
- Velcro attached flaps allow access to handle, top hat and terminals
- Generic fit is suitable for most 10", 12" and 15" speaker cabinets



Type	Speaker size	Dimensions	Order Code
Speaker Bag	10"	490 x 330 x 321mm	441-510
Speaker Bag	12"	630 x 440 x 400mm	441-520
Carry Bag	15"	750 x 520 x 460mm	441-530

Description	Code	Price (Ex VAT)
Speaker Bag for 10" Speaker	441-510	£19.70
Speaker Bag for 12" Speaker	441-520	£21.42
Carry Bag for 15" Speaker	441-530	£25.50

Speaker Dampening x2

63 x 33 x 3.5cm

Optimum dampening wool of sheep's wool and polyester fibre.

- Placed inside cavities to absorb
- For approx. 20 litres
- Dimensions mm 630 x 330 x 35 (2 pieces)



Description	Code	Price (Ex VAT)
White x2	256-930	£7.24
Black x2	256-935	£9.75

Speaker Moulded Foam Sheets x2

100 x 50cm

For the reflection and resonance dampening of cabinet walls.

- 2 sheets each 1m x500mm
- Colour Dark Grey
- * Material class B3 acc. to DIN 4102
- * Density 20 kg/m3

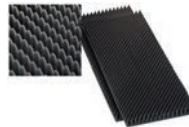

Description	Code	Price (Ex VAT)
Foam Sheets 60mm x2	256-980	£37.50
Foam Sheets 40mm x2	256-990	£29.90

Speaker Cabinet Low Expansion Foam

495 x 300 x 100mm

Low expansion foam, 6 sheets (1m²).

- Sheets are self-adhesive on one side
- Excellent sound absorption, highly efficient even at low frequencies
- Very high volume weight: 300 kg/m3
- Dimensions of each sheet: 495x330x10 mm
- For sound absorption in speaker cabinets and for car hi-fi applications

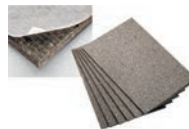

Description	Code	Price (Ex VAT)
Low Expansion Foam x6	258-000	£57.50

Installation Speakers

JBL Contractor Series

Installation Speakers



Control 25/25T Pair

Designed as a mid range model both in size and power handling the 25/25T includes a 5.5 inch bass driver coupled to a horn loaded 2cm (0.75") titanium coated tweeter with a wide dispersion angle. Response is smooth between 80Hz and 16kHz (-10dB points). Power handling is 150watts (continuous programme). Impedance 8Ω, T version 100V line. Sensitivity 88dB. 1W @ 1m.

Control 25AV Pair

As Control 25/25T but with magnetic shielding to protect monitor screens.

Control 28/28T Pair

The Control 28/28T offers the highest power, performance, bandwidth and sensitivity in the Contractor series. It includes a 8 inch bass driver coupled to a horn loaded 2.5cm (1") titanium coated tweeter with a wide dispersion angle. The combination provides a vivid sound reproduction and clarity from 60Hz to 16kHz (-10dB points). Power handling is 175watts (continuous programme). Impedance 8Ω, T version 100V line. Sensitivity 92dB. 1W @ 1m. Dims 380mmH x 280mmW x 220mmD.

Control SB-2 Single

Sub Woofer

The Control SB-2 features a slot loaded vented bandpass sub woofer with a dual voice coil 25cm (10") bass transducer

- Stereo 8 Ohms inputs with satellite outputs
- Dimensions mm 585W x 394H x 343D
- Passive attenuation by use of the Load baffle, a special geometric combination of rigid and pliable materials



Description	Code	Price (Ex VAT)
Control 25 Black Pair	415-140	£215.00
Control 25 White Pair	415-150	£215.00
Control 25T Black Pair	900-037	£232.50
Control 25T White Pair	900-039	£232.50
Control 25AV Black Pair	425-550	£265.00
Control 25AV White Pair	425-560	£265.00
Control 28 Black Pair	415-210	£379.99
Control 28 White Pair	415-215	£379.99
Control 28T Black Pair	425-570	£389.00
Control 28T White Pair	425-580	£389.00
SB-2	415-640	£238.00

THE website

Keep up to date with all the latest products and current prices on the Studiospares website!

check out www.studiospares.com

SATURDAY DELIVERY no problem

DELIVERY BEFORE 10AM no problem

SPEAKERS

Installation Speakers

CONTINUED

JBL Control 1 Pro Pair Installation Speakers

JBL Control 1 Pro features a professional crossover network coupled with professional drivers.

The Control 1 Pro's updated crossover network design provides steeper crossover slopes for exceptional sonic performance. The included wallmount bracket enables the unit to be secured against a wall or other flat surface. Moreover, the rugged moulded enclosure houses magnetically shielded transducers, making the Control 1 Pro well-suited for use with video and computer monitors, or other magnetically sensitive equipment. Dims (mm) 235Hx159Wx143D.



Description	Code	Price (Ex VAT)
Control 1 Black	415-201	£99.95
Control 1 White	425-450	£99.95



JBL Control 5 Pair Installation Speakers

A high performance, wide range control monitor suitable for use as a primary sound source.

- A 6 1/2 inch low frequency driver provides a solid, powerful bass down to 50Hz.
- High frequency response to 20 kHz is handled by a pure titanium 1 inch dome
- Molded enclosure with shielded magnets
- Nominal Impedance: 4 Ohms
- Dimensions mm 387H x 251W x 229D



Description	Code	Price (Ex VAT)
Control 5 Black Pair	415-261	£275.00
Control 5 White Pair	425-460	£275.00

JBL Control C50Pack SUB+4 Installation Speaker

The JBL Control C50 package contains all the elements of the control contractor 50 series.

- Includes one Control 50S/T subwoofer and four control 52S/T satellite speakers.
- Also includes wall-mount brackets.
- Also available in Black.



Description	Code	Price (Ex VAT)
C50Pack Sub+4 Black	445-160	£459.00
C50Pack Sub+4 White	445-165	£459.00

Monacor ETS Series White Installation Speakers

Two high quality column speakers which project the sound both wide and distant with extreme clarity. Colour White.

Monacor ETS-220TW Single White Installation Speaker

2-way version with integrated tweeters for a clearly improved sound.

- Weatherproof and hose-proof
- Rust free extruded aluminium cabinets
- Power rating 20/15/10/5/2.5WRM
- Frequency range 150-20,000Hz
- Speaker compliment 4 bass + 2 tweeters
- Normal SPL 89dB 1watt @ 1 metre
- Dimensions mm 80x469x70
- Weight 1.7kg



Monacor ETS-240TW Single White Installation Speaker

Similar to the 220TW but with the following differences:

- Power rating 40/30/20/10/5W RMS
- Frequency range 150-20,000Hz
- Speaker compliment 8 bass + 4 tweeters
- Normal SPL 90dB 1watt @ 1 metre
- Dimensions mm 80x846x70
- Weight 2.8kg



Description	Code	Price (Ex VAT)
ETS-220TW/WS 100V x1	258-080	£82.50
ETS-240TW/WS 100V x1	258-090	£107.50

Stageline SPE-8U x1 Ceiling Speaker

High-quality 2-way coaxial speaker system with very good sound characteristics.

- 8" bass speaker with glass fibre cone
- 1" dome tweeter with titanium cone
- Plastic tray for flush mounting in walls or solid ceilings
- Impedance 8Ω
- Normal SPL 89dB; Maximum SPL 104dB
- Power 60 watt peak, 30 watts RMS
- Mounting cutout mm 242x242; Depth 100



Description	Code	Price (Ex VAT)
SPE-8U x1	256-870	£57.50

Monacor EUL-30 Pair White 100V Line Speakers

100 volt line installation speakers with five switchable power ratings suitable for wall or ceiling mounting.

- 5 switchable powers 15/7.5/4/2/1watts RMS
- Normal SPL 87dB; Maximum SPL 98dB
- 5" Bass and 11mm dome tweeter
- Frequency range 80-20,000Hz
- Movable mounting bracket.
- Can be mounted in corners due to the bevelled shape of the cabinet



Monacor EUL-60 Pair White 100V Line Speakers

As EUL30 but with the following differences: Frequency range 60-20,000Hz, Normal SPL 89dB; Maximum SPL 100dB, 6" Bass and 11mm dome tweeter, Dimensions mm 215x290x172.

Monacor EUL-80 Pair White 100V Line Speakers

As EUL30 but with the following differences: Frequency range 40-20,000Hz, Normal SPL 89dB; Maximum SPL 103dB, 8" Bass and 11mm dome tweeter, Dimensions mm 270x370x220.

Description	Code	Price (Ex VAT)
EUL-30 x1	255-675	£42.50
EUL-60 x1	255-685	£89.30
EUL-80 x1	255-695	£129.50

Monacor EDL-8 Ceiling Speaker 200mm

Utilises a full range speaker with 4 power taps at 2, 4, 6 and 10 watts power output.

- 200mm (8") 100 volt line speaker
- Frequency range 60Hz - 14kHz
- Quick fixing through a 220mm hole in a ceiling thickness between 10-43mm
- Minimum depth 68mm
- Plastic housing with a metal grille



Description	Code	Price (Ex VAT)
EDL-8	255-010	£24.66

SOCIAL networking

You can now be kept up to date of all things new at Studiospares via the following sites:



follow us on all our social media platforms!

THE website

Keep up to date with all the latest products and current prices on the Studiospares website!

check out www.studiospares.com

Studiospares Forte BG208 Pair

Installation Speakers

This BG208 installation speaker drives competitive products into a corner...

The 208 is a 100 watt (200 watts peak) two way system driven by carefully matched speakers, the tweeter via a horn for an increased angle of dispersion. The 8" woofer is a chunky high flux neodymium magnet driver with a roll surround and with a voice coil of flat copper wire to raise the efficiency. The moulded plastic cabinet includes internal bracing to minimise cabinet resonances (distortion) and the steel front grille stops fingers poking holes in the speakers. The BG208 still sounds "sweet" at high power levels. In comparison, competitors frequently sound "honky". Supplied complete with mounting bracket for vertical or horizontal installation. Inputs on 1/4" Jack & binding posts; Link output on 1/4" Jack. Specification: Frequency response 60Hz - 20kHz, sensitivity 93dB (ref 1 watt@1m), impedance 8Ω, Max SPL 113dB, dimensions mm 410H x 230W x 280D, weight 10kg

Description	Code	Price (Ex VAT)
BG208 Pair	248-620	£115.83
BG208 Single	248-621	£60.33
BG208A Active Single	249-270	£82.50
BG208 Spare Bass Driver	248-629	£16.25



Studiospares BG205 Pair

Installation Speakers



For background music installations, announcements or as a multichannel surround sound application, the BG205 takes some beating, even at treble the price. It is really solid. Low frequencies are handled by a 5 inch driver with an enormous magnet, highs by a soft domed 0.75" tweeter.

- Ferrofluid filled tweeter handles 40W RMS (120W peak)
- Overall power handling 50W RMS (150W peak); Impedance 4Ω
- Complete with a solid wall bracket
- Dimensions mm 226H x 152W x 130D



Description	Code	Price (Ex VAT)
BG205 Pair	248-600	£37.50
BG205 Single	248-601	£19.58
BG205T 100V Line Version Pair	248-680	£33.25

Studiospares Forte BG206 Pair

Installation Speakers

For quality sound installations, the BG206 is without equal even at double the price.

The BG206 is ideal where a wide dispersion angle is necessary and clarity and a clear tone are essential. The two way system consists of a 6.5" (16cm) woofer with a soft roll surround and a huge magnet system. This ensures low frequencies are reproduced with practically no distortion and the high efficiency makes less demands on the amplifier so everything runs cooler. The 1" soft domed tweeter is driven via a crossover network and provides a natural and uncoloured sound. It is filled with a ferro fluid to dissipate any heat when driven hard. The 206 delivers 80 watts RMS (150 watts peak). This system sounds excellent and with different packaging, would merit a Hi-Fi label. Supplied complete with a mounting bracket. Inputs on 1/4" Jack and binding posts; Link output on 1/4" Jack. Specification: Frequency response 80Hz-20kHz, impedance 8Ω, sensitivity 91dB (ref 1watt @ 1m), Max SPL 110dB, dimensions mm 360H x 200W x 232D, weight 4.5kg.

Description	Code	Price (Ex VAT)
BG206 Pair	248-610	£74.58
BG206 Single	248-611	£39.00
BG206A Active Pair	249-280	£48.00



SPEAKERS

Portable PA Systems

Studiospares EGG100/EG200

Wireless Portable PA System



A small comprehensive highly portable wireless PA system that packs punch and can go anywhere.

- Two versions. Dynamic Handheld or Beltpack with Lavalier and Headworn mic
- 6W RMS output. (peak power 12W)
- Inputs: Mic, Line, Auxiliary, MP3 SD Card and USB
- Outputs: Line, Headphone (mutes speaker output)
- Audio controls: MP3/Aux USB Volume, Echo, Equalisation, Volume
- MP3/USB controls: Volume, Mode, Forward /Back
- Built in rechargeable battery, charges automatically
- Additional 12volt DC input
- Dims mm: 300H x 230W x 190D



EGG100



EGG200

Description	Code	Price (Ex VAT)
EGG100 Headset	250-220	£162.50
EGG200 Handheld	250-230	£162.50

Studiospares Forte PA System

Compact PA System



A roll around bag containing everything required to quickly set up a versatile PA system for a hall or large room.

- Power 2x 100 watts RMS (2x 200 watts (peak music power))
- 2 Mic channels with XLR and line level inputs
- Each with 2 Band EQ, Effects Send, Monitor and Level
- Digital Effects Processor with 16 effects
- Digital Effects Processor
- 7 Band Graphic Equaliser
- Complete with 3 stands, Dynamic Mic, all leads and a roll around bag



Description	Code	Price (Ex VAT)
Forte	250-240	£332.50

ALL PRICES EXCLUSIVE OF VAT.

SPEAKERS

Portable PA Systems

CONTINUED

Fender Passport Studio

Portable PA System

The world's first truly portable world-class studio monitoring system

Passport Studio houses a world-renowned Focal® driver set in a portable, protective and meticulously tuned enclosure, complemented by convenient front-panel controls and connectivity. Travel from tracking to mixing sessions down the street or across the country, with complete confidence that your monitors will arrive unharmed. 120V, Black, 150W of output power.

Interlocking cabinets with handle grip for driver protection and extreme portability, front-ported enclosures, universal voltage power supply (supports 110V-240V operation), built-in cable storage, and magnetic rear doors.



Description	Code	Price (Ex VAT)
Passport Studio	211-050	£310.83

Fender Passport Mini

Portable PA System

Goes anywhere thanks to its dual AC- or Battery-powered capabilities.

- Output Power 7 Watts
- Controls: Vocal Channel Volume, Tone, Reverb Level
- Controls Instrument Channel: Volume, Preset, Effects, Tap, Tempo Button
- Inputs: 2x Jacks one with 20dB Pad Switch
- Auxiliary Input Stereo Minijack
- Headphone Output Stereo Minijack



Description	Code	Price (Ex VAT)
Passport Mini	211-060	£82.50

Fender Expo

Portable PA System

Portable full-range sound for audiences up to 300.

- Elegant small-footprint design
- 1" Neodymium Horn-Loaded Tweeter
- Eight Custom-Designed 3" Neodymium Midrange Drivers
- Multi-Pin Connection System Steel Stability Bars
- Two 6.5" Sub Speakers
- Power/Signal/Limit/Protect Indicator LEDs
- Stereo XLR Line Outputs



Description	Code	Price (Ex VAT)
Expo	211-040	£478.33

Samson Expedition XP40iW

Wireless Portable PA System

An all-in-one portable sound system that offers everything you need to deliver a professional and memorable presentation.

Designed for providing quality sound reinforcement in public address settings. Includes built-in VHF wireless microphone system.

- 6-inch woofer and a 1-inch high frequency driver
- 40 watts of power from a lightweight Class D amplifier
- iPod dock with level control
- XLR, jack and minijack inputs



Description	Code	Price (Ex VAT)
XP40iW	388-640	£199.00

Fender Passport Conference

Portable PA System

Perfect for the layperson who needs quality with simple functionality.

- 175 watts of power
- Included microphone kit contains mic, cable, clip in zipper pouch
- Five-channel mixer
- Inputs 3x XLR and 5x 1/4" mic/Line and 1x Stereo Minijack
- Volume and tone controls
- Stereo output for headphone monitoring and stereo mixes



Fender Passport Event

Portable PA System

A self-contained seven channel portable audio system that includes everything you need.

- 375 Watts output
- Channel Controls Volume, Treble, bass, Reverb, 20dB pad
- Hi Z Instrument/Line Switch
- Bluetooth Pair Switch
- Inputs, 4x XLR Mic/Line, 1x Jack Instrument/Line, 2x Stereo Mic/Line
- 1x Stereo Bluetooth
- Speakers 2x 8" and 2x 1.2" Horn Loaded Tweeters



Fender Passport Venue

Portable PA System

Lets you record WAV audio files using a USB flash drive and play WAV and MP3 files.

- 600 watts output
- Input Channels: 10x (4x Mic/Line, 2x Line/Hi-Z, 2x Stereo plus USB
- Channel Controls: Volume, Treble, Bass, Reverb and Phantom Power
- 20dB Pad (chans 1-4)
- Controls for Reverb: Time and Tone, Master Volume
- USB (Record, Play/Pause, Previous/Next Track
- Outputs: 3x Line inc Headphone, 1x Sub Output



Description	Code	Price (Ex VAT)
Passport Conference	211-000	£235.00
Passport Event	211-010	£474.17
Passport Venue	211-020	£554.17
P5-512 Powered Sub	211-030	£257.50

Behringer Europort EPA150

Portable PA System

Ultra-compact 2x 75W, 5-channel portable PA system in a briefcase format.

- FBQ feedback detection system
- Power, performance and light weight
- Studio-grade 24-bit stereo FX processor with 100 awesome presets including reverb, chorus, flange and various multi-effects



Description	Code	Price (Ex VAT)
EPA150	383-220	£185.00

1000s of products Available from stock!

VISIT our trade counter You'll get friendly advice and immediate access to 8000+ product lines!

THE website Keep up to date with all the latest products and current prices on the Studiospares website! check out www.studiospares.com

Studiospares Trojan iPA800

Portable PA System

A substantial and versatile Portable PA system with an internal battery pack for outdoor operation. Innumerable uses throughout industry and education.

The iPA800 provides three Inputs. Chan1. Balanced Microphone input, Chan 2. Unbalanced Mic/Line input, Chan 3. CD L&R, Tape or iPod. There are equalisation controls for high, mid and low EQ and a master volume control. A rear panel jack socket provides an output for a mixer or PA system. An iPod plugs into an appropriate socket on the horizontal top panel. Under an adjacent lid is a receptacle for a microphone (included) plus space for it's lead. The iPA800 includes an 8" bass driver and tweeter so will never lack punch, clarity or sound "muddy" The 15 watts (22 watts peak) output is sufficient to fill a modest sized room. A 35mm top hat in the base allows for it to be mounted on a speaker stand. The internal batteries are automatically recharged from the mains whilst the iPOD can be charged at the flick of a switch. The unit is substantial and includes two rollers for easy transportation. Additionally, two substantial handles make lifting in and out of cars much easier. This product will give a good account of itself and will always be a pleasure to use.



Description	Code	Price (Ex VAT)
iPA800	250-210	£115.83
iPA800 + Stand + Bag	250-211	£132.50
iPA800 + Microphone Stand + Bag	250-212	£124.17
iPA800 + Stand + Microphone Stand + Bag	250-213	£140.83



Samson Expedition XP510i

Portable PA With iDock

An all-in-one portable PA system offering outstanding power and convenience.

- Dual 2-way speaker enclosures, powered mixer with built-in 500 watt Class D amplifier
- 10-channel mixer with built-in iPod dock, four mic/line inputs, three stereo inputs and phantom power
- Custom 10" woofers in 2-way enclosures



Description	Code	Price (Ex VAT)
XP510i	388-780	£499.17

Samson Expedition XP308i

iDock Portable PA System

With powerful, full-range sound in an all-inclusive portable package, the Expedition XP308i is an ideal single system solution for a variety of live sound applications.

- Compact PA system with dual 2-way speakers, mixer and 300-watt amplifier
- All pieces connect into a single, portable case
- Internal 2 x 150-watt lightweight Class D amplifier
- Built-in iPod dock



Description	Code	Price (Ex VAT)
XP308i	388-630	£308.33

Studiospares iPA10

Portable PA System

A Roll Around PA system with a multitude of application and multiple facilities.

- 10" bass driver for increased output
- Soft domed tweeter and a more powerful amplifier
- Output power 30 watts RMS (60 watts peak music power)
- Dock for iPad etc. 35mm top hat socket on underside
- Mic input on Combi XLR/Jack
- Aux/CD/Tape input via phono connectors
- EQ: Bass, Mid and Treble
- Comprehensive set of controls for MP3 playback
- Inputs for MP3, USB, Bluetooth plus conventional microphones and line level devices.
- USB charging point for iPad.



Description	Code	Price (Ex VAT)
iPA10	250-250	£149.17

JBL EON615

Bluetooth PA System

Delivers the best sound possible regardless of its application.

- Optimized enclosure designs for ideal acoustic resonance
- JBL Waveguide Technology
- Bluetooth integration
- Self powered 15", two-way, bass-reflex system
- Max SPL Output 127 dB
- Freq. Response 50 Hz - 20 kHz



Description	Code	Price (Ex VAT)
EON615 x1	445-340	£415.83

SPEAKERS

Induction Loops

Monacor LA-200

Active Loop Amplifier

Active loop amplifier, in constant current technology with a volume compressor for setting up an inductive hearing system.

- Loop Current 7 Amp peak, loop resistance 0.2 - 2Ω
- Room size up to 200 m² (2000 ft²)
- Mic/line inputs on XLR and Jacks
- Alarm facility by connecting to a switch
- Bass and treble controls boost and cut



Description	Code	Price (Ex VAT)
LA-200	255-630	£169.00

Monacor LR-200

Inductive Receiver

Inductive receiver, for receiving audio signals in inductive hearing systems.

- Mini Jack socket for headphones > 32Ω
- Volume control, low cut switch, belt clip
- Powered by a 9 Volt battery
- Dimensions mm 63W x 100H x 29D



Description	Code	Price (Ex VAT)
LR-200	255-640	£33.50

MORE PRODUCTS online

SATURDAY DELIVERY no problem

DELIVERY BEFORE NOON no problem

DELIVERY BEFORE 10AM no problem

ALL PRICES EXCLUSIVE OF VAT.

INDEX

Stands	
Microphone Stands	178
Mic Supports	183
Mic Mountings	185
Microphone Stand Accessories	185
Table Stands	186
Low Floor Stands	187
Studio Monitor Stands	188
PA Speaker Stands	189
Speaker Stand Accessories	191
Wall Brackets	192
Music Stands	192
Laptop Stands	194
Music Stand Lights	194
Guitar Stands	195
Other Stands	197
Keyboard Stands	197
Benches + Stools + Chairs	198
iPhone/iPad + Tablet Stands	198
Lecterns	201
DJ Stands	201
Workstations	201

STANDS

Microphone Stands

Studiospares Instrument Mic Stand

Microphone Stand And Boom

Great for miking up in confined spaces.

- Height variable between 560mm - 860mm
- Boom arm length variable between 530mm - 910mm
- Black powder coated finish for clean looks and durability
- Cast iron base with rubber feet and a diameter of 180mm provides good stability



Description	Code	Price (Ex VAT)
Instrument Mic Stand	448-860	£15.40
Instrument Mic Stand - 4 Pack	448-864	£46.90

K&M Overhead Stand
Microphone Stand

Especially designed for studios and drummers.

Taller than most stands. Long legs provide greater stability when used at maximum height. Legs fold for storage. Zinc die cast base. Height 1120mm to 2010mm. Boom length 1065mm.

Stand and boom threaded 3/8". Made in Germany. Black finish.



Description	Code	Price (Ex VAT)
Overhead Stand	428-250	£52.40

K&M Telescopic Soft Touch Grey

Stand + Boom

The K&M microphone stand is literally the standard by which all others are judged.

- Grey non reflective stand with a rubbery type of telescopic adjusting sleeve
- Height can be adjusted between 92.5cm and 1.63m
- The boom arm extends from 42.5cm to 72.5cm
- The base is die cast for added strength



Description	Code	Price (Ex VAT)
Soft Touch Grey Stand	438-480	£39.50

K&M ST252

Multi Purpose Stand

A really useful multi purpose stand that reduces to 60cm and doubles for miking up bass drums and cabinets.

- Three part telescopic stand
- Height extends from 60cm to 1.5m
- Telescopic boom arm has a reach of 49cm to 79cm
- Heavy Duty finish and sturdy construction
- Stand and boom threaded 3/8"
- Made in Germany



Description	Code	Price (Ex VAT)
ST252	428-320	£42.50

K&M Heavy Duty Stand
Microphone Stand

Designed to support overhead microphones.

Two stands and one boom arm are available. These stands remain very stable even with boom arm fully extended. Both stands feature locking height-adjustment mechanism for added safety. Tall version includes additional safety ring. Collapsible design for easy transport and storage.

Stand and boom threaded 3/8". Colour Black.

Sold As A Package

Description	Code	Price (Ex VAT)
Heavy Duty Mic Stand and Boom	408-501	£125.00
Tall Heavy Duty Mic Stand and Boom	428-360	£175.00

Sold Individually

Description	Code	Price (Ex VAT)
Heavy Duty Stand 148-229cm	428-340	£61.40
Tall Heavy Duty Stand 180-440cm	428-330	£119.50
Heavy Duty Mic Boom Arm with counterweight	428-350	£59.20

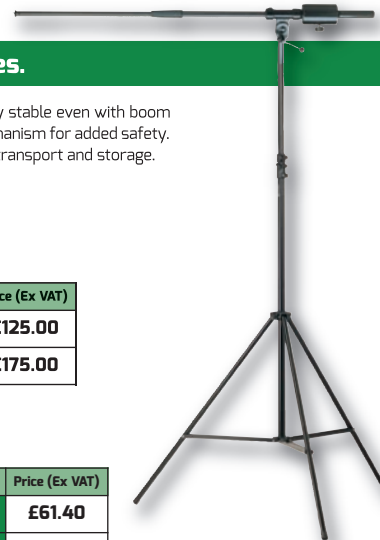

K&M KÖNIG & MEYER
Stands For Music

K&M Round Base Anti-Vibration Stand

Microphone Stand

The K&M 26010 has a 3.6kg iron base with anti-vibration rubber insert.

- Finished in an attractive Soft Touch powder coating.
- Height variable from 870mm to 1575mm
- Base diameter 250mm
- Stand threaded 3/8"
- Extra Heavyweight version with a 5.4kg base
- Colour Black; Made in Germany



Description	Code	Price (Ex VAT)
26010 Grey	428-290	£32.40
26010 Black	438-410	£27.95
26010 Nickel	438-420	£28.95
Extra heavyweight version	438-430	£32.50

K&M 26145

Microphone Stand/Boom Round Base

A well constructed stand with a cast iron base and a sleek clutch mechanism for easy height adjustment.

- Height adjustable between 1000 - 1700mm
- Boom Arm telescopic 470-770mm
- Spigot and boom arm threaded 3/8"
- Base diameter 300mm
- Rubber ring under base stops floor borne transmission of noise
- Colour Black; Weight 6.2kg



Description	Code	Price (Ex VAT)
26145	478-980	£51.90

Sontronics Matrix-10

Heavy Duty Mic Stand

Professional-quality mobile microphone stand.

- Aluminium with 3kg counter weight
- Detachable three wheel dolly with its own carry bag
- 1.2m boom arm extends to 2.25m
- Each wheel has a foot-operated brake; Height: 1.12m to 1.7m



Description	Code	Price (Ex VAT)
Matrix-10	325-180	£157.50

VISIT
our trade counter
You'll get friendly advice and immediate access to 8000+ product lines!
free parking for 40 cars

K&M Telescopic Stand

+ Telescopic Boom Arm

The K&M Stand has become the standard by which all others are judged.

Easily the most popular stand ever produced, and for the very good reason that it is sturdy, reliable, and engineered to stand up to being regularly transported around. Available in Black, Nickel or Grey finish.

Telescopic stand height adjustable between 90cm and 160cm. Fixed length Boom arm 84cm long. Type 211.
Adjustable length Boom arm 42.5/72.5cm

Note: Boomless version 20130 has shorter legs, so may not be suitable for adding a boom later.

Stand and boom threaded 3/8". Spare parts always available. Made in Germany.

Black

Description	Code	Price (Ex VAT)
Stand only without Boom	408-850	£29.90
Stand with fixed Boom	408-860	£34.50
Stand with fixed Boom - 3 Pack	408-863	£91.50
Stand with telescopic Boom	438-460	£39.50
Stand with telescopic Boom - 3 Pack	438-463	£102.50

Nickel

Description	Code	Price (Ex VAT)
Stand only without Boom	408-031	£31.50
Stand with fixed Boom	408-021	£34.50
Stand with telescopic Boom	438-470	£39.90

Grey

Description	Code	Price (Ex VAT)
Stand and telescopic Boom	438-480	£39.50

This soft touch Grey model includes a revised material for the telescopic clamp.

OVER 2 MILLION SOLD!



K&M KÖNIG & MEYER
Stands For Music

K&M 26085 Round Base One Hand

Microphone Stand

Round base microphone stand.

- One-hand clutch means the height can be adjusted with a quick squeeze
- Sleek, flat, cast-iron base
- Weight: 3.2kg
- Height: 1060/1790mm



K&M 25680 3 Legged One Hand

Microphone Stand

Same as round base version above but with folding legs. Height variable between 1.1m and 1.82m. Weight: 2.1 kg.

Description	Code	Price (Ex VAT)
26085	428-520	£37.60
25680	428-510	£39.40

WHY buy K&M?



K&M are a German manufacturer who specialise in manufacturing stands, mainly microphone and speaker varieties. Every part is a precision component manufactured to an exacting specification. Literally every broadcast authority, recording studio, touring band and just about everyone else either exclusively uses K&M stands or uses them for critical situations. Every component is documented and replaceable. Their vast product range also includes music stands, instrument stands and 19" equipment. All spare parts are available and they offer a 5-year warranty. K&M also attaches great importance to environmental protection.

If you need more information, please contact our technical sales team, who will be glad to help further.

Studiospares Short Mic Stand

Fully Telescopic

Popular for miking up instruments and cabinets and still in constant demand by engineers who find black stands on stage visually inappropriate.

- Chrome and Grey finish
- Built to a standard and not a price
- Base is cast from zinc not plastic
- Height can be set from 560mm up to 800mm
- The telescopic boom extends from 530mm to 910mm
- End of boom arm threaded 3/8" with a 5/8" adaptor
- Legs fold for easy transportation



Description	Code	Price (Ex VAT)
Short Mic Stand	448-440	£18.50
Short Mic Stand - 6 Pack	448-446	£92.40

ALL PRICES EXCLUSIVE OF VAT.

Microphone Stands

STANDS

CONTINUED

Studiospares Short Boom Stand

+ Telescopic Boom

A realistically priced low microphone stand manufactured to a standard, not a price.

It is equally at home in the studio or on stage. This is a full function stand finished in matte Black. The boom arm can be removed or set at any length or angle. Height is adjustable. The boom arm is 53cm long extended reducing to 30cm retracted. The folding legs are long enough to provide good stability should a heavy microphone be used with the boom arm fully extended. The end of the boom arm is threaded 5/8" and is supplied with a 5/8" to 3/8" thread adaptor. The thread between the stand upright and boom arm is 5/8". For durability, the base unit and telescopic height adjusting sleeve are metal, not plastic. When tightened, screws do not gouge marks in metalwork.

Manufactured to the ISO9001 standard. These stands are imported by Studiospares in container loads and sold directly to the end user, hence the highly competitive price.

The design may change slightly without prior notice.



Description	Code	Price (Ex VAT)
Short Boom Stand and Boom Arm	448-320	£17.50
Short Boom Stand and Boom Arm - 6 Pack	448-326	£87.00
Trojan B500 Bag for Microphone Stand	458-860	£5.57

Studiospares Stacking Mic Stand

Microphone Stand

In any situation where a quantity of stands with round bases have to be stored, the stacking variety is a popular answer.

- Heavy 24.5cm diameter cut away bases with rubber feet
- Height adjusting clutch mechanism makes height setting easy and incorporates a profiled surface. (see inset)
- Height variable between 88cm - 157cm
- Threaded 3/8"; Colour Black



Description	Code	Price (Ex VAT)
Stacking Stand	448-850	£9.95
Stacking Stand - 4 Pack	448-854	£35.80

Studiospares Easygrip

Microphone Stand and Boom

Modern styled stand with contemporary looks which still retain the traditional quality engineering of its predecessor.

- Boom arm can be easily removed
- Legs do not wobble and setting screws do not mar the surfaces
- Stand height variable between 85cm and 155cm
- Boom extends from 530cm to 910cm
- Boom angle set with a diameter wheel style knob for easy setting



Description	Code	Price (Ex VAT)
Easygrip	448-840	£14.80
Easygrip - 6 Pack	448-846	£78.00

Studiospares Heavy Duty Stand

Microphone Stand

A durable and solid microphone stand ideal for where extra height and stability are required.

Heavier microphones extended on long boom arms can be unstable. This model includes the stability of a speaker stand within a microphone stand. The legs can be set to extend outwards to provide greater stability. The all metal design combines aluminium tubing and steel fittings for portability and strength. It is well thought out and gives flexibility on all parameters. Used extensively on stage and larger studios.

Height variable between 1400mm - 2000mm.
Boom variable between 950mm - 1520mm.
Matte chrome finish.



Description	Code	Price (Ex VAT)
Heavy Duty Stand	465-180	£109.00

Studiospares RB100

Cabled Round Base Mic Stand

Stand with internal cable and switched mic holder.

- Avoids unsightly cables hanging down the stand
- The cable is concealed within the vertical poles and terminates at an XLR socket just above the base
- Mic holder spigot threaded 5/8" (or for a stand with a 3/8" thread use a 401-090 thread adaptor)
- Rewired switched XLR socket attached to the top of the telescopic pole
- Connection via recessed XLR just above the base: No hanging cables.
- Height adjustable between 975-1735mm
- Base cast iron, diameter 220mm
- Base underside includes 3x rubber isolation pads to stop floor borne noise
- Colour Black



Description	Code	Price (Ex VAT)
RB100	449-870	£23.90

K&M 23230

Trilobular Table Mic Stand

Affordable table microphone-stand in a new attractive form, compact and practical.

- Low stand with a distinctive trilobular base (triangle form)
- Holds the microphone reliably and securely in place
- The circular rubber insert ring filters foot step sounds, reduces the transmission of unwanted sounds and provides a non-slip vibration-free stand



Description	Code	Price (Ex VAT)
23230	488-190	£13.75

K&M 234

Adjustable Table/Floor Mic Stand

Black rectangular cast-iron base with tilt angle adjustment.

- 2-piece adjustable extension tubing
- Non-marring height-adjustment mechanism
- Ideal for drums and studios
- Height: from 400 to 640 mm
- Base dimensions: 170 x 135 mm
- Colour: Black
- Weight: 2.09 kg



Description	Code	Price (Ex VAT)
234	488-210	£32.50

Beyerdynamic GST500

Telescopic Boom Stand

Telescopic boom arm version from the popular Beyerdynamic mic stand and boom series.

- Height adjustable from 850-1600mm
- Telescopic boom
- 3/8" thread
- Black finish



Description	Code	Price (Ex VAT)
GST500	430-730	£45.30

DELIVERY BEFORE NOON
no problem

SATURDAY DELIVERY
no problem

DELIVERY BEFORE 10AM
no problem

Studiospares Studio Microphone Stand

+ Telescopic Boom Arm

A realistically priced microphone stand manufactured to a standard, not a price.

It is equally at home in the studio or on stage. This is a full function stand finished in matte Black. The boom arm is telescopic and can be removed or set at any length or angle. Height is adjustable between 94cm and 1.75 metres. The boom arm is 53cm long extended reducing to 30cm retracted. The folding legs are 33cm long to provide good stability should a heavy microphone be used with the boom arm fully extended. The end of the boom arm is threaded 5/8" and is supplied with a 5/8" to 3/8" thread adaptor. The thread between the stand and boom arm is 5/8". For durability, the base unit and telescopic height adjusting sleeve are **metal, not plastic**. When tightened, screws do not gouge marks in metalwork. Manufactured to the ISO9001 standard. The design may change slightly without prior notice.

Description	Code	Price (Ex VAT)
Stand + Telescopic Boom Arm	448-000	£10.75
Stand without Telescopic Boom Arm	448-009	£8.45
Stand Pack 1 Including 5m XLR Lead + Mic Holder	449-720	£15.80
Stand Pack 2 Including 5m XLR Lead + Mic Holder + RED 200	449-730	£35.70
Telescopic Boom Arm without Stand	448-420	£6.93
Stand + Telescopic Boom Arm - 6 Pack	448-006	£55.50
Stand without Telescopic Boom Arm - 6 Pack	448-008	£39.90
Trojan B500 Bag for Microphone Stand	458-860	£5.57

Spares for the Studio Mic Stand

Unlike some other suppliers, Studiospares support our products by supplying spares for items that may need servicing in the future.

Metal Stand Base Components

Description	Code	Price (Ex VAT)
Spare leg with rubber foot	448-100	£3.45
Rubber foot only	448-110	£1.35
Locking screw in base unit	448-120	£1.35

Boom Arm Components

Description	Code	Price (Ex VAT)
Locking screw in boom arm to set length	448-130	£1.35
Locking screw in boom's T Bar to set angle	448-140	£1.35
Locking screw in boom's T Bar to set position	448-130	£1.35

Telescopic Upright Components

Description	Code	Price (Ex VAT)
Spare U-shaped cable clip for stand upright	448-160	£1.35
Spare U-shaped cable clip for boom arm	448-170	£1.35

For each stand sold, Studiospares donate £1 to our chosen charity, Vision for China (was Caring For China's Children). Over £35000 given to date!

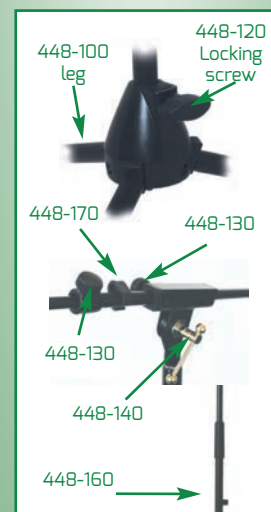

Microphone Stands

STANDS

CONTINUED

Live Budget Mic Stand/Boom

Microphone Stand and Boom

An ingenious design which encapsulates modern technology to reduce manufacturing costs.

Costly metal mouldings are designed out and substituted with tough plastic equivalents.

Height variable between 1000 - 1450mm.
 Boom arm extends 590mm.
 Folded up dimension 1020mm.
 Black powdercoat finish for lasting appearance.
 Quality rubber feet and grips.

Description	Code	Price (Ex VAT)
Mic Stand/Boom	448-090	£9.38
Mic Stand/Boom - 6 Pack	448-096	£49.92



Heil PL-2T

Broadcasters Mic Arm

Provides perfect balance and silent, effortless adjustment of its position.

- Supports microphones weighing up to 1.1kg
- Cable can be easily threaded through the spine by removing the cover plates
- Mic holder spigot can be locked into position
- Mounting Table C clamps up to 37mm thick
- Lower arm 500mm Upper arm 520mm
- Mounts by a 1/2" spigot on arms base
- Mic holder spigot 60mm 5/8" thread



Heil RS-1

12-Inch Riser

Allows you to mount the Heil PL2T Broadcasters Arm behind your desk top equipment and pull the arm over to you.

- Top has a brass insert to accept 1/2" stems
- 300mm High
- Base 75mm with 4x holes allows the RS-1 to be screwed to a desk



Heil SB-2

Adjustable Microphone Boom With Clamp

Good for mounting in tight quarters.

- Telescopic Boom Arm extends from 220mm - 450mm
- Includes Cable clips
- Threads 5/8"
- Ships with a Table top C clamp with a 1/2" brass insert
- Max table thickness 37mm



Heil Mounting Accessories on page 185

Description	Code	Price (Ex VAT)
PL-2T	318-080	£115.83
RS-1	318-100	£24.96
SB-2	318-090	£47.46

K&M 26019

Mic Stand Carry Case



Sturdy carrying case for 3 microphone stand with round base.

- Tearproof nylon material, water-resistant
- Padded handles and an adjustable shoulder strap
- Plastic rubber feet protect the bottom of the case
- 3 separate internal compartments
- Fixed Velcro strips provide maximum protection for the stands

K&M 21315

Mic Stand Carry Case



Sturdy carrying case for 6 microphone stands.

- Separate internal compartments prevent scratching and damage of the stands
- Comes with padded handles and an adjustable shoulder strap
- Plastic rubber feet protect the bottom of the case

Description	Code	Price (Ex VAT)
26019	478-650	£29.20
21315	478-660	£38.80

Studiospares Round Base Mic Stand

Microphone Stand

The stage artist's nightmare, tripping over the legs of the microphone stand, is easily resolved by going to a round base.

- 250mm diameter Black cast iron base to provide stability
- Telescopic section extends to 155cm and retracts to 80cm
- Top is threaded 5/8" with a 5/8" to 3/8" adaptor
- The telescopic part simply screws into the base
- The twist height adjuster is metal, not plastic



Studiospares Big Round Base Mic Stand

Microphone Stand

Brilliant for nervous stage performers or confined spaces.

- Heavy 25cm diameter cast base with shock-absorbing rubber strip
- Top threaded 3/8" Pole unscrews from base
- Adjust height by squeezing the clutch
- Base seems pancake flat so does not present a tripping or stability problem
- Height 1050 - 1900mm



These stands are imported by Studiospares in container loads and sold directly to the end user, hence the highly competitive price!

Description	Code	Price (Ex VAT)
Round Base Stand	448-200	£11.25
Round Base Stand - 4 Pack	448-204	£40.42
Big Round Base Stand	448-050	£29.30

Studiospares Chrome Tube Mic Stand

Round Base Microphone Stand

A chrome stem microphone stand will always be preferred by performers when appearance is a consideration.

- Large 22mm diameter chrome stem
- Large height adjusting diameter clutch mechanism
- Round 25cm cast iron base
- Rubber feet which stop movement and reduce any floor borne noise
- Height adjustable from 86cm - 154cm



Description	Code	Price (Ex VAT)
Chrome Tube Mic Stand	448-830	£11.70

Studiospares One-Hand Stand

Microphone Stand

Heavy duty and affordable one clutch mic stand which easily raises and lowers to the desired height with just one hand.

- One-hand height adjustment
- A genuine one hand stand with a secure grip and smooth operation
- Great for live acts who need simplicity and one hand free.
- Height adjustable between 1125mm - 1675mm
- Zinc alloy, not plastic base
- Proven design
- Mic holder thread size 5/8"



Description	Code	Price (Ex VAT)
One-Hand Stand	449-710	£24.50

K&M Mic Boom Stand

Black Microphone Stand

Entry-level, low-priced microphone stand.

The practical swivel joint allows the one-piece boom arm to be simultaneously positioned for tilt and length. Thanks to a low weight of only 1.85 kg, it is particularly suitable for the mobile musician. The stand requires little space as its base diameter is only 660 mm.

The large foot end caps help to make the stand stable and reduce unpleasant transmission noise.

H: 890 -1600 mm, BL: 680 mm, Weight: 1.85 kg

Description	Code	Price (Ex VAT)
Mic Boom Stand	478-480	£23.40
Mic Boom Stand - 3 Pack	478-483	£55.90

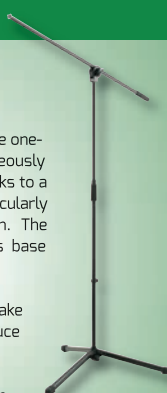

MORE PRODUCTS online

STANDS

Microphone Supports

K&M 23860

Microphone Desk Arm

Black mic arm in a modern design for fast and flexible microphone positioning in studios or multimedia workplaces.

- Aluminium table clamp
- 6m long microphone cable
- 3 pin XLR connection
- Can be attached to a table top of maximum depth 55mm
- Microphones to maximum weight of 1.5kg can be freely positioned



Description	Code	Price (Ex VAT)
23860	478-320	£89.40

K&M 19695

Universal Joint

This flexible universal joint can be used on practically any microphone.

- Includes a 3/8" female thread and 1/4" or 3/8" male thread
- Integrated thread adapter allows for even more combinations
- Dimensions: diameter 29 x 60mm
- Weight: 0.125kg



Description	Code	Price (Ex VAT)
19695 3/8"	478-400	£15.78
19695 1/4"	478-410	£18.70

Studiospares Multipoise Stand

Broadcasters Multipoise Mic Stand

Designed to accommodate those heavy microphones loved by broadcasters and voice-over artists without drooping.

The cable passes through the tubing, with XLR plugs either end, so avoiding the problem of unsightly cables which often become detached. Complete with mic cable & two swivel mounts for screwing to a table top or clamping to a table edge.

Description	Code	Price (Ex VAT)
Multipoise Mic Stand	448-020	£41.58
Multipoise Mic Stand - 3 Pack	448-023	£115.83



K&M Telescopic Boom Arm

The 211/1 is a two section telescopic boom arm with noiseless adjustment.

- Non scratching swivel joint
- Easy tightening with a T bar locking screw
- Minimum length 460mm, extended 765mm
- All threads 3/8"
- All component parts available as spares
- Available in Black and Nickel



Description	Code	Price (Ex VAT)
Telescopic Boom Arm - Nickel	408-090	£17.50
Telescopic Boom Arm - Black	408-370	£17.40

Studiospares Telescopic Boom Arm



We hold all spare parts in stock. Adjustable between 530mm and 910mm.

Description	Code	Price (Ex VAT)
Black	448-420	£6.93
Chrome	448-450	£6.93

K&M 23850

Microphone Desk Arm

This microphone arm keeps the position selected.

This new improved version has a weight capacity of 0.8kg and includes the 5m cable together with a female XLR. The Black powder coated finish is extremely durable. The arm has a 3/8" spigot for mounting a microphone holder. A surface mounted clamp accommodates desk top thickness up to 55mm.

Made in Germany.

Description	Code	Price (Ex VAT)
23850 Arm	428-380	£65.20
Surface Clamp	428-390	£11.20



Studiospares Music Holder



A useful device for handling music or notes which attaches to the microphone stand. The tray is 300mm high x 420mm wide. The black powder coated finish always looks smart.

Description	Code	Price (Ex VAT)
Mic Stand Music Holder	449-790	£12.25

K&M Counterweight

Used for heavy microphones.

- Fits all one-piece K&M boom arms with 3/8" thread connector or tube diameter 15mm
- Easy mounting
- Weight: 0.8 kg
- Outside diameter: 46mm. H: 60mm



Description	Code	Price (Ex VAT)
Counterweight	438-650	£13.50

K&M Drinks Holder

Attaches to music, microphone and instrument stands up to 28mm diameter by an adjustable clamp.

- Suitable for cans, glasses and bottles
- Nickel finish
- Made in Germany.



Description	Code	Price (Ex VAT)
Drinks Holder	407-220	£7.49

K&M 21160 Short Mic Boom Arm

Short one-piece boom arm with 3/8" thread.

- Locking washer and plastic grip
- Smooth adjustment
- Easy to tighten with wing nut
- Weight: 0.5 kg, BL: 395mm



Description	Code	Price (Ex VAT)
21160	428-010	£11.60

K&M 258 Table Clamped Boom Arm

The 258 consists of a telescopic boom arm extending from 540mm to 1000mm

- Can be rotated through 360°
- All component parts available as spares
- Made in Germany



Description	Code	Price (Ex VAT)
Table Clamp	408-410	£27.40

DELIVERY BEFORE NOON
no problem

SATURDAY DELIVERY
no problem

Microphone Supports

STANDS

CONTINUED

Studiospares B100

Broadcasters Multipoise Mic Stand

Designed for voice-over artists and broadcasters keeping the mic position selected even with heavy microphones.

- Arm plugs into desk clamp.
- Cable hidden inside aluminium arm.
- Internal tension springs counterbalance heavy broadcasters microphones
- Will not drop even when raised above centre hinge
- XLR lead included
- Mic holder spigot threaded 5/8" 27 TPI



Description	Code	Price (Ex VAT)
B100	448-180	£49.99

K&M Accessories

Even K&M stands can need attention. These are the most popular replacement items. Always in stock.

Boomlocking screw Code 408-680

T Piece body (with square hole) Code 408-640

Tommy bar incl 2 knobs Code 408-690

Friction washer each Code 408-700

Swivel head with eye Code 408-630

Cable Clip Code 440-650

Base T screw Code 408-710

Telescopic clamp sleeve now inc Plastic Olive Code 408-660

Leg and rubber foot complete

Black 408-510

Nickel 408-515

Folding leg hinge. New replacement kit 7-201-300655 fits all K-M mic stands Code 440-420

We hold all spare parts in stock. Adjustable between 530mm and 910mm.

Description	Code	Price (Ex VAT)
Boomlocking Screw	408-680	£2.24
Tommy Bar including 2 knobs	408-690	£5.80
Friction washer each	408-700	£1.94
Cable Clip	440-650	£0.99
Rubber Foot only	408-650	£1.95
Telescopic Clamp Sleeve	408-660	£3.90
Base T Screw	408-710	£2.99
Leg and Rubber Foot - Black	408-510	£7.50
Leg and Rubber Foot - Nickel	408-515	£7.50
Swivel head with eye	408-630	£3.95
T Piece Body	408-640	£4.40
Plastic folding leg hinge	440-420	£4.25

Rode Boom Pole



Five section lightweight telescopic fishpole 3 metres extended and collapses to 0.84m. 3/8" threaded spigot.

Description	Code	Price (Ex VAT)
Boom Pole	417-170	£65.83
Boom Pole Bag	417-510	£24.17

Rode Mini Boom Pole



A shorter 3 section Mini Boom Pole which is lighter and hence easier to handle. Extends from 0.85m to 2.05m.

Description	Code	Price (Ex VAT)
Mini Boom Pole	417-350	£57.50
Boom Pole Bag	417-510	£24.17

Rode PSA1

Studio Arm

The professional way to mount your microphone to a worktop or studio desk.

Rotates 360 degrees with a maximum reach of 820mm (32.5") horizontally and 840mm (33") vertically. 3/8" thread adaptor. Holds up to 2Kg (4.4lbs). Includes two desk mounting options. 2-axis swivel mount for accurate positioning.

Description	Code	Price (Ex VAT)
PSA1	417-380	£65.83



K&M 16080

Microphone Stand Headphone Holder

A double headset designed to be mounted directly on the microphone stand with slots on the front in-ear pieces.

- Attaches to any mic stand with a screw clamp
- Keeps headphones close at hand and out of harm's way
- Soft rubber-covered construction
- Fits Tubes up to 30mm in diameter
- Holds 2 standard and 2 in-ear headphones



K&M 16085

Headphone Holder With Table Clamp

The new headphone holder including an innovative table clamp is a guaranteed secure and comfortable holder for your headphones.

- Attaches to a wide variety of tables up to 53mm clamping range
- Innovative table clamp for secure and comfortable holding position
- Steel material construction
- Soft rubber-covered construction
- Holds 2 standard and 2 in-ear headphones



Description	Code	Price (Ex VAT)
16080	478-840	£9.80
16085	478-740	£24.90

K&M Fishpole



10 ft. (4 part 0.87m to 3.2m) High quality lightweight Fishpole with warm velvet material handgrip. Extends to 3.2 metres and collapses to 0.95m in three sections. Mic thread 3/8inch. Finish anodised titan. Includes a carrying case. Weight 850g. This is easily Europe's most popular fishpole.

Description	Code	Price (Ex VAT)
Fishpole	401-641	£62.20

DELIVERY BEFORE 10AM no problem

Studiospares SMH1

Switched Microphone Holder

A really useful mic mounting accessory to make an installation look more professional.

- Includes an ON-OFF switch
- XLR connecting cable plugs into the rear downward facing XLR socket
- Enables microphones to be plugged in to the system without having to rearrange the connecting cable
- Stand threaded 5/8". Use adaptor 401-090 for 3/8" threaded stands
- Useful for gooseneck microphones



Description	Code	Price (Ex VAT)
SMH1	449-860	£7.40

Studiospares Angled Stand Adaptor

3/8-5/8 Adaptor

A really useful angled microphone mount.

- The angle can be adjusted through 90 degrees
- The stand thread is 5/8" and the microphone stud thread is 3/8"
- If the microphone holder has a 5/8" thread use Studiospares adaptor 401-100
- If the stand has a 3/8" thread use a Studiospares adaptor also 401-100



Description	Code	Price (Ex VAT)
Angled Stand Adaptor	449-780	£8.30

K&M Lightweight 2-Piece Fishpole



Essentially a scaled down version of the larger model with two not three sections. Practically a third of the weight. Collapses to 635mm and extends to 1600mm. Carrying case included. Colour Grey.

Description	Code	Price (Ex VAT)
Lightweight 2-Piece Fishpole	428-720	£42.30

Heil 1/2" Mounts

Table/Desk Mounting Hardware

Compliments Heil PL-2 and SB-2.

FL-2 Desk Top Flange Mount

- 1/2" brass insert for the PL-2 and SB-2
- Screws to the desk with 3 screws

DT-1 Desk Top Flush Flange Mount

- OK for desk thicknesses between 12.5mm and 50mm. Hole 37mm dia.

WM-1 Wall Mount Holder

- With a 1/2" brass insert
- Secured by 3 screws



Description	Code	Price (Ex VAT)
FL-2	318-110	£23.29
DT-1	318-120	£29.13
WM-1	318-130	£18.29

K&M Multipurpose Microphone Arm



The 24050 multipurpose arm clamps to the stand upright or to flat surfaces. Comes complete with adjustable and swivelling arm threaded at both ends with a 3/8" thread. All component parts available as spares. Colour Black, length 250mm

Description	Code	Price (Ex VAT)
Multipurpose Microphone Arm	408-080	£18.60

STANDS

Microphone Mountings

Studiospares Stereo Mic Bar



Stereo bar with fixing bolts set 160mm apart. All threads are 5/8". If using microphone holders with 3/8" threads use Studiospares adaptor (Code 401-090). If using with a mic stand with a 3/8" thread use a Studiospares adaptor (Code 401-100).

Description	Code	Price (Ex VAT)
Stereo Mic Bar	449-770	£8.30

HOSA MMH-346

Quad Mic Holder



The Hosa MMH-346 quad microphone holder allows convenient access to 4 ball microphones.

- It will mount on standard microphone stands. (microphones and stand not included!)

Description	Code	Price (Ex VAT)
MMH-346	595-840	£25.30

K&M Stand/Bench Clamps



STAND CLAMP KM238

BENCH CLAMP KM237

Black Code 438-610

Black Code 438-600

Description	Code	Price (Ex VAT)
KM238 Black	438-610	£12.75
KM237 Black	438-600	£9.95

K&M KM235

Stereo Bar



KM235 Metal stereo bar 18cm long.

New improved design has slots at both ends so it can be adjusted for extra convenience. Threaded 3/8".

Description	Code	Price (Ex VAT)
KM235	409-110	£11.40

Multi Microphone Bar



Consists of four self retaining threaded screws passing vertically through a Black metal bar. They are tapped with 3/8" threads and are fitted with 3/8" to 5/8" adaptors.

Description	Code	Price (Ex VAT)
Microphone Bar	448-220	£5.47

STANDS

Microphone Stand Accessories

MicFX Sensation Stand Sleeve

Microphone Stand Sleeves

Can be seen on major TV and tour shows.

- Fits all microphone stand makes and models up to 56"
- Also suitable for tripod and round base stands
- Available in Silver, Gold, Red, Purple, Green, Pink and Blue



Description	Code	Price (Ex VAT)
Silver Mic Stand Sleeve	735-000	£12.49
Gold Mic Stand Sleeve	735-010	£12.49
Red Mic Stand Sleeve	735-020	£12.49
Purple Mic Stand Sleeve	735-030	£12.49
Green Mic Stand Sleeve	735-040	£12.49
Pink Mic Stand Sleeve	735-050	£12.49
Blue Mic Stand Sleeve	735-060	£12.49

Studiospares RED 301/302/303

Stand Isolators



Stands not included.

Get a cleaner mic sound in the studio or on stage. These unique new designs improve the quality of your recordings by isolating your microphone stands from the floor or desk, stopping the sound from transmitting through your stand and on to your microphone's recordings. The RED 300 isolators are also useful in live situations, isolating the mic from the floor can help reduce feedback. Made from high density foam and available in 3 versions for different types of stands. RED 301 is for use with large 25cm round based stands, while the RED 302 is for use with small 13cm round based stands. RED 303 is a set of 3 Isolators suitable for any tripod mic stand. Unique new wave design allows each stand isolator to hold the mic stand leg firmly. Significantly reduces noise and vibration transfer through the floor.

Description	Code	Price (Ex VAT)
RED 301	465-270	£9.99
RED 302	465-280	£8.32
RED 303 - Set of 3	465-290	£9.99

K&M 23910

Quick Release Adaptor for Microphones

Makes quickly switching of microphones or other accessories on stage or in studio easier.

- Made of high-quality aluminum
- The lower section is screwed into the 3/8" or 5/8" mic stand thread
- The upper section is screwed on using a 3/8" or 5/8" mic clamp or holder or to other accessories
- A thread adaptor is included with the delivery for 5/8" threading



Description	Code	Price (Ex VAT)
23910	488-180	£12.49

K&M Spare Boom Arm Washer

Available in two colors black and chrome.

- For use with K&M range of mic booms
- Made of steel
- RoHS exempt
- Made in Germany



Description	Code	Price (Ex VAT)
Chrome	703-127	£1.25
Black	703-128	£1.65

K&M Knurled Knob

Works as a M6 x 12 mm KM211 knob bolt for AKG and KM 210 and KM211 boom arm extensions.

- Konig & Meyer knurled knob thumb screw
- Designed for AKG and K&M boom arms
- RoHS exempt
- Made in Germany



Description	Code	Price (Ex VAT)
Knurled Knob 01.82.828.55	408-685	£2.20

STANDS

Table Stands

Studiospares Short Table Stand

Solid short table stand with a Matte Black non reflective finish.

- Heavy cast 12.5cm diameter base supported on a soft rubber ring to minimise table borne low frequency disturbances
- 13cm stem unscrews from base
- Stem threaded 3/8inch



Description	Code	Price (Ex VAT)
Short Table Stand	448-260	£8.62

V-Shaped Table Mic Stand

Heavy-Duty Desk Stand

Heavy 'V' shaped base, offering extra stability.

- Flexible gooseneck
- Stylish black metal and chrome finish
- Standard 5/8" thread and rubber feet
- Height: 280mm



Description	Code	Price (Ex VAT)
V-Shaped Stand	475-840	£9.95

Telescopic Table Gooseneck Stand

Microphone Stand

Heavy duty telescopic mic stand with a heavy base.

- Gooseneck 150mm, 5/8 inch thread
- Chromed vertical pole 180mm
- Telescopic part extends 140mm
- Black painted base has rubber feet
- Base diameter 150mm
- Will support heavier microphones



Description	Code	Price (Ex VAT)
Table Gooseneck Stand	476-390	£12.80

Mini-Angled Mic Stand

Table Stand

Mini microphone stand with cast "V" base.

- Telescopic stem
- Multi-angle base joint
- Supplied with cable retainers and thread adapter
- Foldaway compact design
- Height: 310 - 460mm



Description	Code	Price (Ex VAT)
Mini-Angled Mic Stand	476-170	£19.20

A

K&M 23220

Low Profile Table Stand



Heavy cast iron 13cm diameter base supported on soft rubber to minimise table borne low frequency disturbances. Mic mount is threaded 3/8". Matte Black non-reflective finish.

Code 438-550

B



Telescopic Stand

23cm-38cm. Steel base dia 13cm. Inexpensive

Code 401-910

C



JHS Telescopic Table

Black stand 22cm - 33cm
Cast base dia 16cm 5/8" thread

Code 408-620

D



JHS Black Telescopic + Boom

Stand 28cm - 40cm. 31cm Boom. Base dia 16cm. 5/8in thread.

Code 408-670

E



ST12 Telescopic Table

Stand 35cm - 55cm. Steel base dia 17cm

Code 408-050

F



Short Stand

11cm high. Steel base dia 10cm. 3/8in thread.

Code 401-570

G



K&M 221A Table Flange

Black base and tube with 3/8" thread. Wt: 0.2 kg H: 155 mm Base-diameter: 73 mm.

Code 478-620

PLEASE NOTE. PICTURES NOT TO SCALE.

Description	Code	Price (Ex VAT)
A 23220	438-550	£21.50
B Telescopic Stand	401-910	£13.90
C Telescopic Table	408-620	£12.55
D Black Telescopic + Boom	408-670	£23.90
E ST12	408-050	£26.30
F Short Stand	401-570	£8.92
G 221A	478-620	£13.50



WANT a job?

Are you looking for a stable and rewarding career?

Studiospares are constantly expanding. We require additional staff for a variety of positions, working in a very congenial atmosphere. Practical experience of recording and/or live sound engineering would be preferable.

send in your CV in the first instance

Studiospares Gooseneck Table Stand

Gooseneck will not droop when loaded with a heavy microphone.

- Heavy cast 12.5cm diameter base supported on a soft rubber ring to minimise table borne low frequency disturbances
- 26cm gooseneck unscrews from its base; Gooseneck threaded 3/8"



Description	Code	Price (Ex VAT)
Gooseneck Table Stand	448-270	£3.98

Studiospares Collapsible Table Stand

Short Tabletop Stand

A foldable and variable height low table stand.

- Collapsible tripod base
- Metal construction
- Does not include mic clip



Description	Code	Price (Ex VAT)
Collapsible Stand	448-880	£7.35

Studiospares Tripod Table Stand

Variable Angled Telescopic Stand

A tripod stand for portable recorders with a 1/4" male thread which can be angled.

Compatible with most hand held recorders. Variable height between 130-190mm. Effective rubber feet. Threaded spigots angle can be varied and locked in position.

Description	Code	Price (Ex VAT)
Tripod Tabletop Stand	448-080	£1.99



Studiospares Tripod Table Stand

Tabletop Stand

An attractive telescopic tripod table stand that will grace any desktop.

Bright chrome finish. Includes a 3/8 to 5/8 inch thread adaptor.

Description	Code	Price (Ex VAT)
Tripod Tabletop Stand	449-280	£8.20



K&M 25900

Variable Height Low Boom Stand

Low-level, telescopic stand with folding legs.

- Comes with extendable boom arm
- Attractive Grey Soft-Touch powder coating
- Height adjustable 42.5cm to 64.5cm
- Boom adjustable between 47cm and 77.5cm
- Weight: 2.2 kg



Description	Code	Price (Ex VAT)
25900 Grey Soft Touch	438-530	£39.80
25900 Black Chrome	438-510	£38.20

Studiospares AVS-2

Anti-Vibration Drum Floor Stand



The boom arm is not included.

Ideal for recording kick drums without picking up floor-borne vibrations. Favoured by drummers to get the microphone within a hair's breadth of the skins. Built in Anti Vibration Pad gets rid of stage-borne noise usually generated by the drummer!

Description	Code	Price (Ex VAT)
AVS-2	449-250	£16.60

Portable Recorder Stand

1/4 Inch Thread

A table stand designed for field recorders.

- 1/4 inch thread
- Includes a lead tidy



Description	Code	Price (Ex VAT)
Portable Recorder Stand	256-030	£6.25

Low Floor Stands

K&M 25935

Extra Low Microphone Stand

The K&M 25935 is a small boom mic stand perfect for bass, drums, guitar amps and other instruments.

- Adjustable telescopic bar (460-765mm)
- Height: 260mm
- Weight: 1.4 kg
- Color: Black



Description	Code	Price (Ex VAT)
25935	478-850	£24.99

K&M 23320/23323

Microphone Table Stand

Low stand with a heavy cast iron base for maximum stability.

- Height adjustable between 217-347 mm
- Base diameter 250mm
- Base material; Cast iron
- Anti-vibration rubber insert for noise filtration
- Thread diameter 3/8"
- 23323 - Same specification as 23320 but with a height of between 350 - 570 mm



Description	Code	Price (Ex VAT)
23320	488-070	£23.90
23323	488-080	£24.90

K&M 25960

Anti-Vibration Telescopic Boom Stand



Provides great stability and immunity from floor borne noises.

The K&M 25960 has a heavy 250mm diameter cast iron base with an anti vibration mat inset on the underside. The boom arm is telescopic extending from 420mm to 720mm. The stand is 430mm high. The boom arm can be tilted through a wide angle and locked into position. Stand and boom threaded 3/8". Colour black.

Description	Code	Price (Ex VAT)
25960	408-560	£36.20

K&M 25950

Extra Low Bass Drum Mic Stand

Specifically designed for bass drum or special use, this very low stand is only 305mm high.

- Very short and heavy legs provide maximum stability
- Legs are foldable for easy transport
- Comes with two-piece boom arm 21140
- Weight: 2.8 kg



Description	Code	Price (Ex VAT)
25950	428-020	£34.40

K&M 25910

Short Microphone Boom Stand

Provides good stability with three folding legs.

- Height 305mm
- Boom arm is 525mm long and can be slid back and forth
- Frequently used for bass drums or similar acoustic requirements
- All component parts available as spares
- Stand and boom threaded 3/8"
- Made in Germany
- Black chrome finish



Description	Code	Price (Ex VAT)
25910	407-090	£28.50
25910 - 3 Pack	407-093	£78.90

FOR
fax orders
Use our fax number...
020 8450 4390

MORE PRODUCTS
online

STANDS
Studio Monitor Stands

Studiospares Telescopic Stand Monitor Stand

A substantial and well engineered stand designed to support studio monitors.

The 23cm x 23cm supporting surface has wide rubber strips to grip the monitor.

The height can be adjusted between 75cm - 130cm. A retained pin passes through the upper telescopic pole to protect the speaker from damage should the clutch adjustment mechanism not be properly tightened. The base is triangular, each side is 440cm long.

Description	Code	Price (Ex VAT)
Telescopic Stand	448-870	£14.20
Telescopic Stand - 4 Pack	448-874	£48.40



Studiospares Treble Triangle Stand Monitor Stand

Fixed height Stand designed to support studio monitors.

Two rubber strips grip and protect the speaker cabinet. Fixed height 900mm. Supported by three square tubes. Supplied with screw in spikes to penetrate carpets. Black powder coated finish will still look smart after years of use. Base 450 x 450 x 450mm. Plate 230 x 230mm.

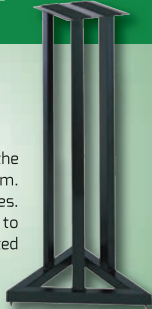

Description	Code	Price (Ex VAT)
Treble Triangle Stand	449-290	£13.80

Isoacoustics L8R Range Speaker Stands

Built on patented isolation technology that allows speakers to "float" in free space, letting you hear authentic sound.

- Superior Isolation and sound clarity for speaker systems
- Improves imaging and definition
- Speaker and stand movement kept on axis
- Fully adjustable for height and tilt
- Base size 6.1 x 7.5 in, fits most monitor speakers
- See www.isoacoustics.com to see which L8R is best for your speaker



Description	Code	Price (Ex VAT)
L8R155 Pair	403-870	£71.25
L8R130 Pair	403-872	£52.50
L8R200 Pair	403-875	£106.67

Studiospares MS140 Tripod Monitor Stand

The MS140 is a telescopic universal monitor stand with feet not legs so tripping is less likely.

The MS140 is a universal monitor stand designed to be unobtrusive and occupy minimal studio floor space. The height can be set between 690mm and 1500mm. The height locking screw assembly also includes a locking pin which passes through the telescopic tube. The feet occupy a floor area of 450mm x 450mm x 450mm. The plate size is 230mm x 230mm. Neoprene protects the underside of the speaker cabinets. The plate can be removed and the stand used as a conventional pole stand. The upper pole has a diameter of 35mm.

Black powder coated finish for maximum durability. Manufactured under ISO 9001.

Description	Code	Price (Ex VAT)
MS140	449-460	£18.30



Komodo Monitor Stands Pair

Dual Tubed Monitor Stands

An attractive dual tubed studio monitor stand designed to satisfy the most discerning user.

- Adjustable floor spikes and foam pads are provided.
- Removable metal spikes under the base bypass the sound dampening effect of carpeting.
- Stable and attractively finished
- 2 height options, 400mm and 800mm
- Supplied flat packed. Assembly takes a few minutes.



Description	Code	Price (Ex VAT)
KOMODO 400mm Pair	448-060	£22.50
KOMODO 800mm Pair	448-070	£33.20

Trojan Pier Pair

Isolation Speaker Monitor Stands

An ingenious means of elevating speakers from floors or desktops whilst providing excellent isolation since the uprights have internal springs either end.

- Two height options, 150mm and 274mm depending on which set of tubes are used
- Set at 90° the size is 208 mm x 208mm
- At other than 90° the length become greater as the width becomes smaller
- Supplied unassembled
- Maximum load 25kg



Description	Code	Price (Ex VAT)
Pier pair	449-890	£32.50

K&M 26740 Monitor Stand

Stable steel stand for monitors with broad completely level round cast-iron base-diameter 450mm.

- Rod combination height adjustable
- Direct attachment of monitors with 3/8" threaded joint
- Screw in connector plate 205 x 245mm
- 4 thread points and 4 rubber knobs
- Load capacity: 35kg



Description	Code	Price (Ex VAT)
26740	438-700	£68.50

Ultimate MS90 Pair Monitor Stands

Offer unparalleled innovation and strength for professional, project and home studios alike.

- Features non-slip, high density acoustic foam
- Adjustable base that allows the end user to fine tune the sweet spot
- Column monitor stand with cable management
- Three internal channels for cable and weight management
- Available in two heights



Description	Code	Price (Ex VAT)
MS90/36B 36"	420-410	£166.63
MS90/45B 45"	420-420	£189.00

1000s
of products
Available from stock!

VISIT
our trade counter
You'll get friendly advice and immediate access to 8000+ product lines!

Studiospares AMS100

Adjustable Angled Desktop Monitor Stand

Allows you to precisely set the angle of the monitor.

No more wedging material under your speakers to maintain the angle for that "sweet spot". The speaker stands on a non slip high density foam pad which isolates the speakers acoustic energy to the speaker and not it's supporting surface. That surface is protected by rubber feet. Maximum capacity 35kg. Dimensions 320mmL x 262mmW x 110mmH. The angle is adjustable by a worm gear screw. A well engineered product.



Description	Code	Price (Ex VAT)
AMS100 - Sold Singly	449-840	£32.50

Studiospares AMS200

Adjustable Monitor Stand

Provides a high degree of acoustic isolation and can be tilted and turned through 90 degrees.

It is designed to accommodate any desktop type speakers including their feet. The two L support bars can be set at any distance apart from 167mm- 267mm. The speaker is held in place by telescopic horizontal bars with rubber end stops which can be set to restrict any forward movement. Speaker depth can be set between 235mm and 263mm. The rear upright supports include adjustable buffers which can be locked in any vertical position. Sold singly.



Description	Code	Price (Ex VAT)
AMS200 - Sold Singly	449-850	£62.50

B-Tech Atlas Range Pair

Speaker Stands

Twin columned stands which are genuinely fillable for added performance.

- Floor plate has unique curved corners
- Adjustable floor spikes, top spikes and foam pads are provided
- Stable, look good and are well finished
- Black with finish with 3 heights, 400mm, 600mm and 800mm
- Sold as a pair



Stand	Description	Code
BT604B	Black 400mm high (top plate dimensions 190 x 190mm)	426-130
BT606B	Black 600mm high (top plate dimensions 160 x 160mm)	426-140
BT608B	Black 800mm high (top plate dimensions 125 x 125mm)	426-150

Description	Code	Price (Ex VAT)
BT604B	426-130	£39.50
BT606B	426-140	£41.50
BT608B	426-150	£43.50

PA Speaker Stands

STANDS

Live PA Speaker Stand

Speaker Stand

A lightweight aluminium speaker stand with a large capacity.

The Live PA Speaker Stand is high on quality and low on weight. Anyone on the road will appreciate having to carry less weight. The Live PA Speaker Stand sells in the tens of thousands due to its quality and reasonable price. The height can be set between 1250mm and 1850mm and the load capacity is a whopping 60kg. The upper pole is 35mm diameter to interface with current speaker top hats. The locking pin offers reassurance that the upper telescopic pole will remain in place should the locking clamp not be fully tightened.

Studiospares import these stands directly from the manufacturer by the container load selling them directly to the end user so cutting out the "middle man" In consequence our price will lower than anyone else.

Description	Code	Price (Ex VAT)
Speaker Stand	449-350	£14.92
Speaker Stand x2 + Carry Bag	449-360	£29.17



Studiospares Airpump Speaker Stand

Airpump Speaker Stand

The speaker literally drops down on a column of air with the Studiospares Airpump Support.

- Leg support assembly is metal, not plastic
- Pole locking mechanism is non marring
- Variable height between 1.2m and 2.2m
- Maximum load is 60kg
- Upper pole diameter is 35mm
- For 38mm sockets use Studiospares sleeve
- On a cost effective basis alone, this product comes second to none



Description	Code	Price (Ex VAT)
Airpump Speaker Stand	448-820	£27.40

K&M 21460

Speaker Stand

World class lightweight aluminium speaker stand with double-braced folding base.

- Few speaker stands get German GS approval, this does
- Approved for loads up to 50kg
- Extension tube diameter 35mm
- Height-adjustable 1375 to 2185mm
- Foldable and light weight (3.5kg) for easy transport
- Packed in a cardboard box
- Made in Germany



Description	Code	Price (Ex VAT)
21460 Black	418-120	£74.50
21460 Aluminium	438-690	£72.50

SOCIAL networking

You can now be kept up to date of all things new at Studiospares via the following sites:



follow us on all our social media platforms!

Studiospares Amp/Combo/Speaker Stand

An adaptable and versatile stand with a high stability factor.

- Footprint 420mm wide and the legs are spaced 500mm front to back
- Variable height 610mm - 740mm
- For transportation the legs fold together
- Remains stable even when knocked
- Space underneath for additional gear
- Fabricated from steel and Black powder coated for durability



Description	Code	Price (Ex VAT)
Combo Stand	448-470	£19.50

ALL PRICES EXCLUSIVE OF VAT.

STANDS
PA Speaker Stands

CONTINUED

Studiospares PA Speaker Stand Single

All Metal

One of the most popular stands sold worldwide!

The strength of a speaker stand is highly dependent on the base unit which, on stands in this price bracket will be made of plastic. This model uses a zinc casting. The upper pole is 38mm reducing to 35mm at the top. Reversing the pole will provide a 38mm diameter. The dual telescopic height adjustment includes the normal compression clamp plus a substantial pin that passes through both the poles. The pin includes a ball catch to stop it working free plus a woven nylon tie line to save the pin from being lost. Both the compression telescopic clamp and the securing screw in the base are designed NOT to gouge the paint from the stand when tightened. Tough rubber feet protect the floor surface. Maximum height 2.2 metres, maximum safe carrying capacity 60kgs. Collapses down to less than 1090mm. Powder coated finish for a lasting clean appearance and durability. All components available as spare parts.

Description	Code	Price (Ex VAT)
PA Speaker Stand	448-300	£29.50
PA Speaker Stand x2 + Bag	448-301	£56.67
PA Speaker Stand 4-Pack	448-304	£104.00

NEW PAIR PRICE
£55

Extended Version single

Heavier duty version extending to 3m and with a 100kg load capacity. Legs are of 38mm diameter tube, main telescopic pole 45mm diameter, middle tube 41mm, upper section 38mm reducing to 35mm at the very top. The longer legs spread further for added stability and security. Construction and features same as the smaller version above. Collapses to 1.2m approximately.

Description	Code	Price (Ex VAT)
Extended Version	448-310	£44.50

NEW PAIR PRICE
£79



STUDIOSPARES

K&M 21450/21459

Speaker Stands

An easy-to-carry speaker stand made of high quality aluminium...

Fiberglass-reinforced fittings and an additional safety pin ensure stable support for the speakers. The height and feet adjust by an easy-to-use clamping lever. Holds up to 50 kg. Wt: 2.45 kg. H: 1270/1930 mm.

21459 consists of 2 x 21450 and a carrying case.



Description	Code	Price (Ex VAT)
21450	478-460	£28.50
21459 - Pair + Carry Case	478-470	£58.29

Studiospares Aluminium Stand Speaker Stand

Popular with users who endeavour to keep their travelling weight down.

This model is very popular with users who endeavour to keep their travelling weight down. The aluminium construction does not diminish the 60kg carrying capacity. To maintain durability, the central base support is zinc not plastic.

The upper pole has a tube diameter of 38mm reducing to 35mm at the top. This can be reversed for speakers with 38mm sockets.

Non marring height adjustment screws as standard. Height variable between 1.0m to 1.85m.

Description	Code	Price (Ex VAT)
Aluminium Stand	448-430	£29.50
Aluminium Stand 2-Pack + Bag	448-432	£56.00
Aluminium Stand 4-Pack	448-434	£99.00



STUDIOSPARES

DELIVERY BEFORE NOON
no problem

SATURDAY DELIVERY
no problem

DELIVERY BEFORE 10AM
no problem

K&M 21435

Speaker Stand Steel Black

Standard speaker stand made with sturdy steel tubing.

- U-profile leg construction
- Non-marring height-adjustment mechanism and safety pin security lock
- Extension tube diameter 35 mm
- GS-approved for loads up to 35kg
- Weight: 5.3kg, H: 1320/2020mm



K&M 21436

Speaker Stand Aluminium/Steel Black

Same as model 21435, but legs and base tube are constructed from aluminium to reduce weight. Extension tube diameter 35 mm. GS-approved for loads up to 35kg. Weight: 3.2kg, H: 1320/2020mm.

Description	Code	Price (Ex VAT)
21435	438-660	£41.50
21436	438-670	£46.50

Studiospares 80kg Wind Up Stand

Speaker Stand

This stand is of an all metal construction and makes light work of raising heavyweight speakers aloft.



Designed to aid the safe installation of speakers up to 80kg at heights between 1.52m and 2.30m. Cranking the handle raises the speaker. The handle part retracts into its own arm for added safety. The top of the telescopic pole has a diameter of 35mm. Both clamping screws push against a metal tongue instead of the thread end gouging the telescopic tubes. All tubes are of powder coated steel. This is a well made product very popular with hire companies.

Description	Code	Price (Ex VAT)
Wind Up Speaker Stand	448-390	£49.80

PRICE match

Studiospares will BEAT any genuine price from any UK competitor on any item or order.

details on page 318

THE website

Keep up to date with all the latest products and current prices on the Studiospares website!

check out www.studiospares.com

Speaker Stand Accessories

Speaker Flange

Pressed steel speaker flange for 35mm poles.

- Depth 100mm, base diameter 110mm
- Dimensions 100cm x 25cm x 14.5cm
- Requires a hole 40.5mm diameter
- Matte Black



External Speaker Flange

Secure any speaker safely to the top of a 35mm pole.

- All metal construction, not plastic
- Dimensions 210mm long x 120mm wide
- Pole depth 50mm
- Fixing holes and slots for maximum versatility



Description	Code	Price (Ex VAT)
Speaker Flange	437-530	£6.40
External Speaker Flange	437-540	£11.40

K&M Mounting Fork

Steel tube combination for 2 speakers, with tube diameter of 35mm.

- Width-adjustable from 310 to 490mm
- Slip-on bolt height of 120mm
- GS-approved for loads up to 2 x 25 kg
- Weight: 1.4kg



Description	Code	Price (Ex VAT)
Mounting fork	438-730	£39.40

K&M 24116

Connector Plate

Speaker connecting plate.

- Secured to the underside of the speaker
- 4x 6.5mm countersunk holes
- Threaded M20
- Use in conjunction with a distance pole



Description	Code	Price (Ex VAT)
24116	478-880	£7.95

K&M 21336/21337

Distance Rod Adjustable

Steel tube combination to connect satellite systems.

- With M20 bolt to attach connector plate 24116 for precise fit
- Tube ends; Both the same 35mm diameter
- Colour Black
- Height variable between 945 - 1475mm
- Construction 2 piece folding design
- Double safety, spring loaded locking pin and safety bolt
- 21337 - Tube Ends, Tube dia 35mm - Threaded M20



Description	Code	Price (Ex VAT)
21336	478-610	£36.40
21337	478-890	£33.30

K&M Mic Stand/Speaker Stand Bags

Speaker Stand Carrying Bags

K&M 21421



Holds 2 K&M mic stands. Made from Black waterproof nylon with silk-screened K&M logo. Two inside compartments with velcro to hold the stands in place and sturdy handles. Zip closure. Weight 0.16kg. Length 1100mm.

K&M 21311



Designed to hold 2 heavy (eg up to 9kg each) speaker stands. Made from Black waterproof nylon with silk-screened K&M logo. Two inside compartments with zip closure and nylon handle. Weight 0.6kg. Length 1200mm.

K&M 21422



Designed to carry 2 K&M microphone stands 21420. Made of Black waterproof nylon. Two inside compartments with cord and sturdy handles. Weight: 0.45kg, L: 1290mm.

Description	Code	Price (Ex VAT)
21421	418-090	£13.70
21311	418-100	£19.60
21422	438-740	£14.15

Studiospares Trojan B506

Large Speaker Stand Bag



High quality stand bags designed for professional use.

- Made of black waterproof hardwearing nylon
- Designed to fit a variety of stands and equipment
- Suitable for mic stands, speaker stands and music stands
- Dimensions 1520 x 160 x 400mm

Description	Code	Price (Ex VAT)
B506	458-920	£9.15

Speaker Safety Wire

Provides the safe support of overhead speakers in the event of the holding bracket or speaker becoming detached.

- Max. weight load: 50kg
- Weight: 124g
- Length: 900mm



Description	Code	Price (Ex VAT)
Eye + Hook Safety Wire	428-770	£11.50

MORE PRODUCTS online

Speaker Stand Accessories

STANDS

CONTINUED

Galaxy Lifesaver LSR38

Stand Stabilizer

A unique equipment stand stabiliser that may be used in a variety of ways in Audio, Video, Lighting, and Theatre applications.

- May be filled with sand or water
- Protects mics and speakers from damage
- Helps keep microphone, speaker and lighting stands upright
- Bag measures: 16" O.D. x 6" I.D. x 3" thick
- Weights: 38 lbs. with SAND, 22 lbs. with WATER
- Sand/Water not included
- Unique doughnut shape keeps bag on the stand
- Weight (product): 0.8 lbs
- Weight (shipping): 1.3 lbs



Description	Code	Price (Ex VAT)
Lifesaver LSR38	223-830	£41.50

Galaxy Saddlebag SDB40

Weight / Stabilizer Bag

Designed to help improve the stability of speaker, keyboard, mic, lighting stands and many other types of stands.

- Helps stabilise a top-heavy stand
- Works great as a boom counterweight
- Constructed of a durable reinforced vinyl
- Weighs approximately 18kg when filled with Sand (not included) and 11kg when filled with water



Description	Code	Price (Ex VAT)
Saddlebag SDB40	223-840	£49.17

K&M 21404 x2

Cable Clamps

Universal Cable Clamp.

- It can secure a total of 12 cables width 4 - 9 mm to speaker and lighting poles
- Diameter 61mm x 16mm thick
- Pole diameters 35mm - 42mm
- Secured in place by Velcro tape
- Keeps cables tidy



Description	Code	Price (Ex VAT)
21404 x2	488-010	£6.95

K&M Warning Strip

Fluorescent collar of heavy duty nylon fabric for better safety especially in poor lighting conditions.

- No more tripping
- Yellow/Black stripes printed with "CAUTION"
- Simply forms a tube to encircle one of the stands' legs
- Secured with Velcro, 600mm x 175mm



Description	Code	Price (Ex VAT)
Warning Strip	438-720	£9.30

Wall Brackets

STANDS

K&M 24100

Heavy Duty Speaker Wall Mount

Fixed position wall mount fabricated from rectangular steel.

- 35mm interchangeable mounting spigot
- Wall to bolt clearance 420mm
- GS approved for loads up to 50kg
- Weight 2.7kg, Height 460mm
- Colour Black



Description	Code	Price (Ex VAT)
24100	428-460	£29.80

Swivel/Tilt Bracket MKII

Speaker Wall Bracket



NEW PAIR PRICE £46

Wall support for standard speakers.

Load capacity 15kg. Supplied with locking screws for a better grip. Tilts speaker up to 30 degrees. Dimensions : Speaker Clamp size = 195mm fully closed 360mm fully open , mounting plate 240mm. Height x 120mm Width. Full length of bracket 400mm - 465mm. Sold singly.

Description	Code	Price (Ex VAT)
Speaker Bracket - Single	255-430	£25.30

K&M Control 1 Bracket Single

Wall Bracket

Screw-on type wall mount to hold a JBL-Control 1 speaker.

- The mounted speaker can be swivelled sideways and tilted
- Weight: 0.6 kg.
- Available in Black or White



Description	Code	Price (Ex VAT)
Control 1 Bracket Black	438-860	£26.50
Control 1 Bracket White	438-865	£26.50

K&M 24161

Universal Speaker Wall Mount / Bracket

NEW



Flexible and compact wall mount for loud speakers up to 15 kg. The variable wall mount has two adjustments - angle and direction. In addition, it keeps the speaker close to the wall. Whether it is used for loud speakers that are equipped with vertical or horizontal drill holes, both options can be mounted easily and securely to the wall mount. The decor-wall plate rounds off the look of this attractive product.

Description	Code	Price (Ex VAT)
24161 x 1	488-200	£45.00

Music Stands

STANDS

K&M 107

Collapsible Heavy Duty Music Stand

Very solid, durable and hard wearing collapsible music stand.

- Attractive Nickel/Black finish
- Fully adjustable plus collapsible for total convenience
- Special adjustment clamps protect the surface finish
- Height adjustable between 850/1650mm
- Transportable length 670mm
- Weight 2.3kg
- Carrying bag is manufactured from a heavy gauge nylon



Description	Code	Price (Ex VAT)
107 Nickel	418-000	£33.20
107 Black	418-010	£33.20
Carrying Bag	418-050	£8.20

K&M Sheet Music Retaining Magnets Pair

Strong magnetic power - mini size, easy to use.

- Steel casing with K&M logo
- 2 Magnets
- Weight: 0.01kg
- Size: Diameter 12 x 16mm



Description	Code	Price (Ex VAT)
Power Magnets	438-910	£3.55

PAYPAL
online payments

Worried about using your credit card online?

We now accept Paypal for online payment!



visit www.studiospares.com for more information

Studiospares DF Series Music Stands

Popular all-metal heavy duty portable orchestral music stands.

The DF series has two options, three legs or three feet. The three feet version is preferred when musicians may trip or become entangled with splayed legs. Both are finished in a Black epoxy resin for maximum durability.

The 3 leg version's height is adjustable from 94cm to 140cm, the flat base version from 110cm to 150cm. The sheet holder measures 47cm by 34cm. Rubber anti-slip feet provide added stability. Built to a standard, not a price.

Description	Code	Price (Ex VAT)
3 Legs	408-830	£29.13
3 Legs 6-Pack	408-836	£149.17
3 Feet	458-010	£29.60
3 Feet 6-Pack	458-016	£139.00

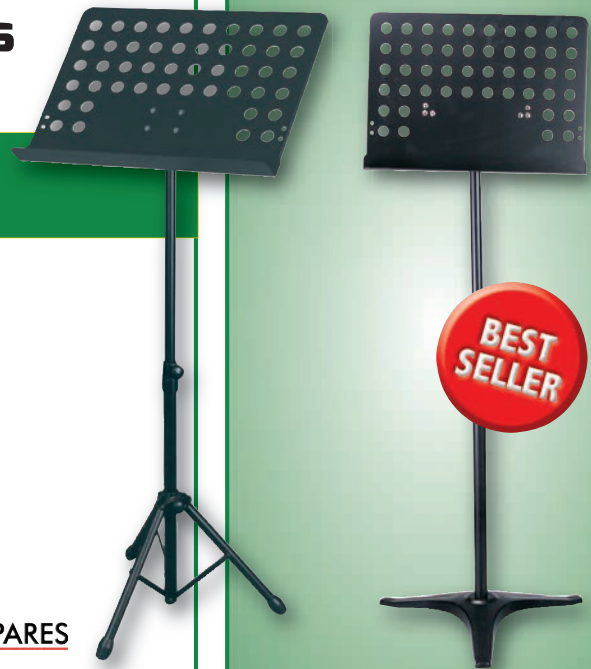

K&M 10100

Music Stand

A well engineered lightweight and compact Music Stand.

- Height 650 - 1225 mm
- 3 part telescopic design so is compact and collapses to 390 mm
- Desk dimensions 440 x 215 mm
- Folded height 390 mm



Description	Code	Price (Ex VAT)
10100 Black	478-900	£14.90
10100 Nickel	478-910	£14.90
11460 Carry Case	478-920	£19.50

K&M 12179

Ultimate Music Stand

This K&M model really does have just about everything.

- Locking base with U-profile steel legs
- Special locking mechanism
- Removable perforated steel music desk
- Height: 610/1080mm
- Weight: 3.2kg



Description	Code	Price (Ex VAT)
12179	438-030	£37.40
11450 Optional Carry Case	418-060	£19.80

Rat Jazz Stands

Music Stand

From flat pack to standing in three moves. No knobs, no finger traps, no hassle.

Stands shown collapsed



Unfolded, the revolutionary Jazz stand is a professional quality music stand with a full range of height adjustment, industry standard stability, and a full size music tray with pencil shelf. Yet, as a result of its unique and patented design, it folds in three moves to a flat pack no larger than the size of the tray, and under 5cm thick. Aluminium alloy legs and stem and polymer tray make the Jazz stand light in weight yet extremely sturdy. When standing, the height of the Jazz stand is adjusted by raising or lowering it to the desired height and leaving it there. Tray stays at whatever angle you set it. There are no knobs to fiddle with or lose. The Jazz stands interlock to an orderly stack. Standing, they nest compactly next to each other. The Jazz stand's unique adjustment when folded, you can pop it in the gig bag, stack it on a pile of other Jazz stands, or put it in a custom made flight case.

Description	Code	Price (Ex VAT)
Jazz	451-160	£69.16
Jazz + Free Bag	451-165	£69.16
Bag - Holds One Stand	451-180	£15.40
Trolley for Jazz Stand	404-670	£207.50

Studiospares Lightweight Music Stand

Heavy Duty

This product by comparison to other lightweight stands would be classed as heavy duty.

- Heavy duty
- Metal base, telescopic clamps and angle adjusters
- Colour Black
- Base remains stable when unfolded



Description	Code	Price (Ex VAT)
Lightweight Music Stand	448-400	£12.40

Studiospares Combo Stand

Guitar + Music Stand

A portable stand of proven quality which combines a fully collapsible music stand and a guitar stand which is devoid of plastic parts.

- Fully collapsible
- Guitar surfaces protected
- 3part telescopic for easy adjustment
- Attractive black powder coat finish



Description	Code	Price (Ex VAT)
Combo Stand	448-810	£9.95

Studiospares Lightweight Music Stand

Extended Portable Stand

This Lightweight Portable Music Stand is height adjustable from 79cm to 165cm.

- Collapses for easy storage or transportation into a small box
- Chrome finish
- Well made considering the price



Description	Code	Price (Ex VAT)
Lightweight Music Stand	458-000	£9.90

PRICE changes

This catalogue was priced on 1st December 2014.

Current prices may be higher...

see our website for up to date prices.

MORE PRODUCTS online

Music Stands

STANDS

CONTINUED

K&M Music Stand + XtraFlex Light

Music Stand + Light

This music stand is perfect for music lessons, band practice or schools.

K&M's collection of music stands helps to make music fun for kids of all ages. This stand folds down in three sections, making it very easy to transport. Packaged with a multi-purpose mini light (Mighty Bright) with extra bright LED (1 piece).

Includes 3 batteries (1.5 V AAA). Gooseneck for a very flexible adjustable light beam. With clip to attach to music stands etc., also suitable as desk lamp.

Very compact and handy size, folded up only 70 x 55 x 50 mm. Weight: 70g.



Description	Code	Price (Ex VAT)
Music Stand + Xtraflex Light	478-770	£12.49
Music Stand + Xtraflex Light - 6 Pack	478-776	£72.00

K&M 10068

Budget Orchestra Stand

Steel constructed orchestra stand with an aluminium music desk.

- Non-marring height-adjustment mechanism to protect the finish
- Height variable from 560 to 1190mm
- Music desk dimensions 480 x 300mm
- Colour Black
- Weight 2.3kg



Description	Code	Price (Ex VAT)
10068	418-070	£32.70

K&M 11520

Music and Sheet Holder

Attaches to stands up to 28mm diameter.

- Fully adjustable
- Nickel plated finish with a Black music holder 300mm x 210mm
- All component parts available as spares
- Made in Germany



Description	Code	Price (Ex VAT)
11520	408-450	£17.20

Studiospares Mic Stand Music Holder

Music Holder

A useful device for handling music or notes which attaches to the microphone stand.

- The tray is 300mm high x 420mm wide
- The black powder coated finish always looks smart



Description	Code	Price (Ex VAT)
Mic Stand Music Holder	449-790	£12.25

K&M 12140

Table Top Music/Laptop Stand

Foldable 3 legged table-top tripod for laptops and multimedia equipment.

- Also suitable for manuscripts, lecture notes and sheet music
- Continuous-tilt mounting plate: 350 x 273mm
- Max. weight capacity 4.0kg
- Weight: 1.3kg; Height: 240mm



Description	Code	Price (Ex VAT)
12140 Black	438-880	£33.50
12140 Silver	438-885	£33.50

Laptop Stands

Studiospares LS100

Floorstanding Laptop Stand

Fully adjustable laptop floor stand and provides a mouse tray which can be left or right handed.

Laptop clamps adjustable in width and depth. Clamps do not interfere with ports, expansion slots or DVD drives. Tray height and tilt adjustable. Tray height 610mm - 1120mm. Laptop tray dimensions 400mm x 300mm. Mouse tray dimensions 165mm x 200mm.



Description	Code	Price (Ex VAT)
LS100	449-550	£38.30

MORE PRODUCTS online

Studiospares Laptop Stand Ultimate

Laptop Stand

Folds completely flat for transportation. Unfolds in seconds.

- Aircraft grade aluminium
- Laptop remains above working area
- Adjustable height shelf for external hard drive or scratch amp
- Folds flat in seconds
- Striking industrial design



Studiospares Laptop Stand Premium

Laptop Stand

Fully adjustable to suit the application and can be used with projectors and a multitude of DJ and studio devices.

- Heavy duty aluminium construction
- Stable and keeps equipment above desk level
- Folds for storage and transportation
- Variable height adjustable between 320mm and 435mm
- Tray size 350mm x 274mm
- Shelf size 203mm x 120mm



Description	Code	Price (Ex VAT)
Laptop Stand Ultimate	449-260	£32.50
Laptop Stand Premium	449-510	£20.79

Music Stand Lights

Mighty Bright Xtra Flex

Stand Light

Multi-purpose and highly affordable mini light with extra bright LED.

- Attaches to music stands etc
- Includes 3 batteries (AAA 1.5V)
- Gooseneck attachment means the light can be adjusted to the exact position required
- Very compact handy size, folds up to only 70x55x50mm
- Colour Black. Weight 0.07kg



Mighty Bright Double Flex

Stand Light

As per the Xtra Flex but with 2 x LED lights.

- Can also be used as a free-standing light
- Colour Black
- Weight 0.09kg



Description	Code	Price (Ex VAT)
Xtra Flex	438-080	£8.32
Double Flex	438-090	£19.30
AAA Batteries (NB 3 included)	402-510	£0.56

K&M 12270

Twin Head Music Stand Light

The K&M 12270 twin head music stand light offers the newest LED technology with both light heads working individually.

- Bright and focused gooseneck light positioning
- Split to work individually 2 x 4 LEDs
- Electric cable 3m length
- Clamping up to 20mm
- Mains operated only



Description	Code	Price (Ex VAT)
12270	478-860	£28.20

Studiospares Music Stand Light

Music Stand Light

A sturdy all metal Music Stand Lamp which clamps onto the sheet holder.

Maximum sheet holder thickness 19.6mm. Can be set for both distance and angle. Supplied with 15 watt mains powered tubular bulb, 2 metres of cable, in line On-off switch and a 13amp moulded mains plug. Not intended for outdoor use.

Colour Black.

Description	Code	Price (Ex VAT)
Music Stand Light	448-410	£14.20



STUDIOSPARES

K&M Music Stand Light

Black



Black light shade with three position tilt adjustment.

Secured to the music stand by a clamping system designed to fit music supports up to 20mm thick. Lighting by a 25 watt tubular bulb which disperses the light more evenly. On-Off switch is part of the mains lead. High quality construction which conforms to German quality standards. Not intended for outdoor use. Supplied with 2m of cable.

Description	Code	Price (Ex VAT)
Music Stand Light	431-300	£21.40
Spare Bulb	510-050	£3.65

LED Bullet Light

Mini Clip On LED Bullet Light.

- Clips on to music stands and lecterns
- Powered by 3x LR44 button cells (supplied)
- On-Off switch at the rear.
- Compact design fits into a pocket



Description	Code	Price (Ex VAT)
LED Bullet Light	476-450	£3.70

K&M Starlight 12235

Music Stand LED Lamp



The brightest music stand light available in our product range.

Innovative LED technology (8 special LED's) produces a pleasant, even and flicker-free light. A new lamp generation featuring long-lasting lifetime, shock resistance and a minuscule power consumption of 4 watts. With elegant gooseneck for a flexible adjusting of the light beam. CE-marked. Rain and moisture protection IP44. Clamping width up to 20mm. 3m power cable with euroconnector.

Description	Code	Price (Ex VAT)
Starlight 12235	428-830	£32.20
Optional Carrying Case 12236	428-840	£7.60

K&M 85650 Mighty Bright Duet 2

Music Stand Light

Universal mini light with 4 extra bright LEDs switched on/off individually.

- Flexible gooseneck for easy light positioning
- Can also be used as a free-standing lamp and with a power supply unit.
- Very compact and practical
- Only 90 x 60 x 50mm when collapsed
- Weight: 0.07kg



Description	Code	Price (Ex VAT)
85650	478-110	£14.96

Guitar Stands

Multi Guitar 5-Way Stand

Guitar Stand

Very convenient for studio or on stage, this rack stand has space for up to 5 guitars or bass guitars.

- Foam covered supports for protection
- Space-saving foldable design
- Sturdy construction and intuitive design
- Dimensions in use: 730 x 630 x 400mm



Description	Code	Price (Ex VAT)
5-way Stand	476-180	£32.50

K&M 17540/17541

Acoustic/Electric Guitar Stand

Stands for electric and acoustic Guitars.

- Stable, sturdy, simple and easy to adjust and fold
- Width adjusts from 220 to 350mm
- Support arms covered with non-marring rubber to protect the instrument
- Weight: 2.0kg, Height: 420mm



Description	Code	Price (Ex VAT)
17540 Acoustic	438-170	£21.50
17541 Electric	438-180	£21.50

FREE catalogue

Are you reading someone else's catalogue? Why not call us and order your own copy...

it's free!

DELIVERY BEFORE NOON no problem

SATURDAY DELIVERY no problem

ALL PRICES EXCLUSIVE OF VAT.

STANDS

Guitar Stands

CONTINUED

Studiospares Wall Guitar Holder

Guitar Holder



A simple but effective guitar hanger keeping the ground space free. The neck of the guitar is protected by rubber bumpers surrounding the metal arms. The arms swivel to avoid stress on the guitars neck. Easily fixed to the wall using the four countersunk holes.

Description	Code	Price (Ex VAT)
Wall Guitar Holder	449-800	£7.90

K&M 16240

Guitar Wall Mount

Screw-on type wall mount which accommodates a wide variety of guitar shapes.

- Patented flexible hooking-in and clamping system
- Studs at support arms provide extra protection
- Support arms covered with non-marring rubber to protect the instrument
- Mounting plate made from high quality plastic material
- Colour Black; Weight 0.2kg



Description	Code	Price (Ex VAT)
16240	478-120	£11.20

Studiospares GS5/GS7

Guitar Stands

A practical stand for safely storing up to 5/7 acoustic or electric guitars.

The GS5 and GS7 are constructed of steel tubing where areas in contact with guitars are protected by a soft EVA tubing which is known to withstand the rigors of stage, school and studio. The total height is 730mm. Plastic feet stop it marking wooden floors. The GS5 and GS7 are black powder coated noted for retaining a smart appearance.



Description	Code	Price (Ex VAT)
GS5 5-Guitar Stand	449-530	£19.99
GS7 7-Guitar Stand	449-535	£27.50

Studiospares Combo Guitar Stand

Suitable for practically all guitars.

Arms and top of A frame are encased in a protective PVC material to avoid scratching. Height 440mm.

Width from 210 to 346mm.

Fabricated from steel and powder coated.



Description	Code	Price (Ex VAT)
Combo Stand	448-460	£9.95
Combo Stand - 5 Pack	448-465	£39.90



K&M 16280

Guitar Hanger

K&M's top quality guitar-holder.

- Screw-mount
- Features flexible support arms for various guitar models
- Arms covered with non-marring rubber to protect the instrument
- Weight: 0.2kg.
- Colour Black



Description	Code	Price (Ex VAT)
16280	408-520	£11.25

Budget Guitar Wall Hanger

Guitar Hanger

Make a little more space in your studio!

- Simple British design
- Metal sleeved in soft foam to avoid damage to guitars
- Allows your guitar to hang securely out of harm's way
- Colour Black



Description	Code	Price (Ex VAT)
Budget Guitar Wall Hanger	421-010	£8.65

K&M Guardian 17513/17515

Guitar Racks

The new Guardian guitar racks from K&M hold 3 or 5 guitars securely, save space and allow you an easy overview of your guitars.

Ideal for use in the studio, on stage, or at home. No matter whether you have acoustic, electric or bass guitars, the special instrument-compatible supports protectively hold up to 3 or 5 guitars. The protective bars stop the guitars from rotating and prevent inadvertent removal or knocks or bumps when taking the guitars from the stand or placing them. The soft pads made of high quality thermoplastic elastomer have cushioning characteristics. Therefore they protectively take the weight of the guitar and avoid damage to the instrument.



Description	Code	Price (Ex VAT)
17513 3-Guitar Rack	478-720	£99.50
17515 5-Guitar Rack	478-730	£126.50



K&M 16250

Guitar Wall Mount

The thick rubber covered steel support arms are safe and secure for all types of guitar.

- Arms are adjusted individually and suitable for guitars with asymmetric necks.
- Guard cams prevent guitar from turning
- Automatic back release mechanism
- Support arms work individually
- The yoke is self locking
- Dimensions 80 x 60 x 116 mm



Description	Code	Price (Ex VAT)
16250	488-060	£11.90

K&M 14580

Pohlmann Guitar Support

Allows you more freedom when handling your guitar, no matter whether playing or quickly tuning the strings of your guitar.

- A quick and clever alternative to a guitar strap
- Contact surface is non slip rubber
- Manufactured from a high quality plastic
- Dimensions 65 x 40 x 112 mm
- Clip the guitar playing-aid to your trouser belt



Description	Code	Price (Ex VAT)
14580	478-940	£9.95

MORE PRODUCTS online

Other Stands

STANDS

K&M 26747

Projector Tray

This well engineered projector tray can be used universally for monitors, outboard equipment, accessories and anything else that fits the tray.



- Tray dimensions 420 x 380 mm
- Fits 35mm poles
- Securing clamp

Description	Code	Price (Ex VAT)
26747	478-990	£39.50

Keyboard Stands

STANDS

Studiospares Variable Height X Frame

Keyboard Stand

Affordable and solidly-constructed keyboard X-stand, especially strong when set for a low keyboard height.



- Solid steel construction
- Arm length (front to back): 350mm
- Height: 380-1130mm
- One of the best of this type of stand that we've seen.

Studiospares Variable Height Z Frame

Keyboard + Mixer Stand

This stand presents a more solid yet lightweight equipment support.



- Rubbery non slip strips along upper edge of equipment support
- Black powder coated finish
- Height variable between 590mm and 900mm
- Width variable between 600mm and 900mm
- Depth 615mm

Description	Code	Price (Ex VAT)
Variable X Stand	448-370	£23.40
Variable Z Frame	448-380	£21.80

K&M Spider Pro

Keyboard Stand

The 'Spider Pro' is a further development of the 'Spider' keyboard stand.



- Made of aluminium for lightness and portability
- Equipped with one pair of extendable arms and one pair of extendable with 15° tilt angle support arms
- Can be fitted with additional support arms for a third keyboard
- Available in Silver or Black

Various accessories and other models are available. See our website for more details.

Description	Code	Price (Ex VAT)
Spider Pro Silver	428-550	£160.16
Spider Pro Black	428-560	£132.50

Studiospares Double Cross Stand

Keyboard Stand without Extension Arms

A well engineered keyboard stand designed to withstand the rigours of the road.



The dual frame provides much greater strength and stability than single designs. The locking mechanism consists of two die cast circular discs a and b each with complimentary hill and dale surfaces. Pressing the locking handle brings both discs together and they remain firmly locked at the same angle. Other locking systems seem crude and cumbersome. This product only uses locking nuts which cannot shake loose and get lost. These stands are imported by Studiospares in container loads and sold directly to the end user, hence the highly competitive price. The manufacturer works in accordance with the ISO 9001 quality standards.

Description	Code	Price (Ex VAT)
Double Cross	448-330	£19.70
Double Cross - 4 Pack	448-334	£68.50

Fixed Angle Keyboard Extension Arms

Simply plug the expanding part into the back of the X Frame or the lower extension arm and tighten the screws. This will cause the plugs to expand securing the extension arms in place. The rear horizontal telescopic bar provides added rigidity.

Description	Code	Price (Ex VAT)
Fixed Extension Arms	448-350	£11.70

Variable Angle Keyboard Extension Arms

Simply plug the expanding part into the back of the X Frame and tighten the screws. This will cause the plugs to expand securing the extension arms in place. The keyboard arms can be set at any angle by a locking system identical to the double X frame above. The rear horizontal telescopic bar provides added rigidity.

Description	Code	Price (Ex VAT)
Variable Extension Arms	448-340	£13.50



Studiospares Keyboard X Stand

Of similar construction to the Double Cross Stand but with a single not double frame. Height (mm) 600-800mm, arm length 400mm. Ideal for keyboards 310-360mm wide.

Description	Code	Price (Ex VAT)
X Stand	448-360	£10.75
X Stand - 4 Pack	448-364	£36.80



K&M 18930/18933

Keyboard X-Stand

An ergonomic clamping mechanism makes setup or break down easy and fast.

- Height from 594 to 964 mm
- Support width 327 - 789 mm
- Support depth 350 mm
- Size when folded 1020 x 102 x 520 mm
- Clamping lever for quick release
- Non-marring slip-proof pad
- 18933 same specification as 18930 but depth is reduced to 250 mm



Description	Code	Price (Ex VAT)
18930 350mm	478-950	£32.50
18933 250mm	478-960	£32.50

K&M Rick 18990

Black Keyboard Stand

Heavy duty adjustable steel construction with double square tubular cross supports.

- Push-button quick-release mechanism
- Non-marring pads on support arms
- Optional stacking arms for second keyboard 18941
- Adjustable end cap to stabilise the stand on uneven surfaces
- Height 480 to 1000mm
- Maximum load capacity 40kg



Description	Code	Price (Ex VAT)
Rick 18990	438-340	£42.20
Arms 18941	438-300	£29.90

DELIVERY BEFORE NOON
no problem

SATURDAY DELIVERY
no problem

DELIVERY BEFORE 10AM
no problem

Benches + Stools + Chairs

STANDS

K&M 14065

Keyboard Bench Seat

A comfortable keyboard bench with high quality imitation leather.

- Height adjustable
- Wobble free design
- Collapses for easy transport
- Dimensions (mm), seat 540 x 300, height 395 to 585
- Colour Black



Description	Code	Price (Ex VAT)
14065 Leather Seat	428-690	£34.50

Studiospares Director's Chair

A comfortable and practical aluminium tubed folding chair. Equally at home by the side of the pool.

- Aluminium tubing is light and will not rust
- Padded armrests which can be removed
- Folds for transportation and storage
- Folding mechanism clicks into place
- Double stitching where it counts
- Modest cost through purchasing directly from the manufacturer and importing by the container load.



Description	Code	Price (Ex VAT)
Director's Chair	635-520	£13.75

Drummer Throne Round Seat

Stool

Adjustable padded seat for drummer or other musicians.

Padded stool with height adjustment, detachable seat and folding tripod base. With a comfortable and thick padded seat, it has a robust and rigid metal construction.

- Tripod diameter: 520mm
- Seat dimensions: 65mm x 280mm
- Height adjustment: 510-635mm
- Weight: 2.36kg



Description	Code	Price (Ex VAT)
Throne Round Seat	475-800	£24.99

K&M 14020

Drummer Throne Picco

A drummer throne for beginners and for advanced players.

- Baseline series with unique clamp (patented push button system)
- Easy handling double braced steel leg construction with large floor protectors
- Small footprint with 540mm diameter
- Comfortable upholstered seat with a durable non-slip leather cover
- Diameter 300mm & Height 485-680 mm



K&M 14030

Drummer Throne Grande

An all-around drummer throne for advanced players and the pro.

- Baseline series and with precision height adjustment mechanism
- Ratchet knob and clamping lever in 10mm steps
- Double braced steel leg construction with large floor protectors
- Medium footprint with 625mm diameter
- Comfortable upholstered seat with a durable non-slip leather cover 330 mm
- Height : 490-690 mm



Description	Code	Price (Ex VAT)
14020	478-780	£41.60
14030	478-790	£62.50

Keyboard Bench

This keyboard bench has an adjustable height, comfortable padded seat and is easy to fold.

- Height: 480 - 650mm
- Seat size: 250 x 530mm
- Weight: 4.7kg



Description	Code	Price (Ex VAT)
Keyboard Bench	475-860	£27.80

iPhone/iPad + Tablet Stands

STANDS

K&M 19772

iPad Stand

Great to use on stage, at home or in the studio.

- iPad is easily clipped into the holder
- Dock-connector and headphone jack are accessible
- Freely rotates 90°
- Suitable for iPad 2nd, 3rd or 4th generation
- Height from 700 to 1,550 mm
- Weight 2.1 kg



Description	Code	Price (Ex VAT)
19772	488-020	£34.90

K&M 19714

iPad Air Stand Holder

A clever way to show off your iPad Air.

- The mount is guaranteed to hold the iPad Air effectively and safely
- For use on stage, in the rehearsal room or at home
- The 3/8" internal thread means the holder can be attached to any mic stand easily and quickly
- Lightning connector and headphone jack are accessible
- Freely rotates 90°
- Weight 0.38 kg



NEW

K&M 19724

iPad Air Clamped Stand Holder

Holds an iPad Air securely and comfortably.

- Strong prismatic element with an ergonomic clamping screw
- To be attached to tubes up to 30 mm diameter
- iPad Air is easily clipped into the holder
- Lightning connector and headphone jack are accessible
- Can be screwed on to 3/8" thread connectors
- Weight 0.65 kg



NEW

K&M 19734

iPad Air Wall Mount

The safe way to use your iPad Air in comfort.

- The mount is simply attached to the wall using the 3 fastening bores
- The iPad Air clips effortlessly in and out of the holder
- Once attached, the iPad Air turns comfortably through 360°
- Lightning connector and headphone jack are accessible
- Weight 0.275 kg



NEW

K&M 19754

iPad Air Table Stand

The mobile table stand for your iPad Air.

- The iPad Air is held safely and securely thanks to the sturdy steel base
- An easy-to-use wing nut adjusts the tilt
- The iPad Air can be rapidly switched between the vertical and horizontal format without slipping
- Weight: 2.852 lbs
- Lightning connector and headphone jack are accessible



NEW

K&M 19774

iPad Air Stand + Holder

The combination of stand and iPad Air holder is great to use on stage, at home or in the studio.

- The iPad Air is easy to clip in and out of the holder
- Tilt is adjusted with an ergonomic clamping screw
- Telescopes in 2 sections
- Can be adjusted to any height between 27.559 and 61.023"
- Folds to a small compact size, which is easy to transport
- Freely rotates 90°
- Weight 4.57 lbs



NEW

Description	Code	Price (Ex VAT)
19714	488-120	£20.82
19724	488-130	£29.99
19734	488-140	£16.20
19754	488-150	£27.50
19774	488-160	£37.50

DELIVERY BEFORE NOON no problem

SATURDAY DELIVERY no problem

IK iKlip Studio Desktop

iPad/iPad2 Stand

An adjustable iPad desktop stand designed specifically for musicians.

- Sturdy, durable, lightweight, shock-resistant thermoplastic construction
- Rubber foot-pads grip the desktop and prevent unwanted sliding
- All controls, buttons, connectors and camera of the iOS device are accessible
- Fast installation-can be mounted in seconds
- Includes detachable iRig bracket for the Amplitube



IK iKlip Mini iPhone/Touch

Mic Stand Adaptor

Offers support to your iOS device on stage, in the studio, at school or in the office.

- Sturdy, durable thermoplastic construction
- Compatible with all previous and current iPhone and iPod touch models
- Firmly attaches to virtually any microphone stand, pole and tripod
- Fast installation-can be mounted in seconds
- Perfect companion to the iRig Mic



IK iKlip iPad/iPad2

Mic Stand Adaptor

Provides easy use of your iPad in any live setting - on-stage, in the studio, at school or in the boardroom.

- Fits both the original iPad and the iPad2 and iPad3 (with included adaptors)
- Sturdy, durable thermoplastic construction
- Universal stand clip securely attaches to virtually any mic stand
- Multi-angled adjustment allows precise positioning for optimal viewing



Description	Code	Price (Ex VAT)
Studio Desktop	321-570	£18.75
Mini iPhone/Touch	321-580	£24.99
iPad/iPad2	321-590	£24.99

Rat Z3

Tablet Floor Stand

The cradle features interchangeable arms which enable any design of tablet - present and future - to be fitted.

- Height 360 and 1140 mm
- Folds to a flat pack in three simple moves
- Fully adjustable so it can be used while lying down, standing or sitting
- Cradle turns 360°
- Single knob secures or releases the tablet
- Anodised aluminium for lightness and strength
- Folds into a neat bag is light and easy to carry



Description	Code	Price (Ex VAT)
Z3 Black with lock	471-610	£110.00
Z3 Black without lock	471-620	£100.00
Z3 Interchangeable arms	471-630	£20.00
Z3 Floor bracket	471-640	£15.00
Z3 Carry Bag	471-650	£16.00

Studiospares iS-8

iPad Mini Holder

An industrious and practical iPad Mini holder built to be practical, not as a fashion accessory.

The holder is held in place on the stand by a non marring adjustable clamp. The holder can be rotated through 360 degrees.

A solid clamping arrangement ensures the holder will not droop when used extensively.

Description	Code	Price (Ex VAT)
iS-8	449-830	£12.49



iPad/Tablet Anti-Theft Floor Stand

Lock design for anti-theft.

- Holds iPad in portrait or landscape orientation
- Fix iPad by holding across corners
- Bendable painted tube provides flexible viewing adjustment length 500mm approx
- Plastic knob for adjusting height
- Adjustable height for optimum viewing



Studiospares iS-14

iPhone Holder

An industrious and practical iPhone holder.

- Held in place on the stand by a non marring adjustable clamp
- The holder can be rotated through 360 degrees
- A solid clamping arrangement ensures the holder will not droop when used extensively



Description	Code	Price (Ex VAT)
iS-14	449-820	£15.80

8.9" - 10.4" iPad/Tablet Holder

For iPad 1,2,3,4,Air & Galaxy and most popular 8.9"-10.4" tablets.

- For fixing on to Microphone / Music stands or poles in a variety of applications
- Suitable for vertical pole mounting only
- Constructed from ABS Plastic, Steel and Nylon
- Clamp width adjustable:14-28mm
- Product weight: 0.35KG



7" - 8.5" iPad/Tablet Holder

Mini iPad,Galaxy and most popular 7"-8.5" tablets clamp mounting.

- For fixing on to Microphone / Music stands or poles in a variety of applications
- Constructed from ABS Plastic, Steel and Nylon
- Use to mount on vertical pole and not horizontal
- Ideal for musical groups, drama, Schools assembly or conference room use
- Clamp width adjustable :14-28mm
- Product weight: 0.35KG



iPad/Tablet Floor Stand and Bag

Tablet Floor Stand for iPad® and most popular brands of 7" - 10" tablets.

- Ergonomic hands-free and adjustable viewing angle design
- Height adjusts from 77" - 154cm / 30.3" - 60.6"
- Stable and sturdy tripod base
- Device easy to detach on the holder
- Base easy to lock into place and fold for storage
- Convenient carrying case supplied



Description	Code	Price (Ex VAT)
Anti Theft Floor Stand	323-000	£65.83
8.9" - 10.4" Holder	323-010	£12.49
7" - 8.5" Holder	323-020	£12.49
Floor Stand and Bag	323-030	£37.50

Studiospares iS-4

iPad Holder MKII

The iS-4 is a multi angle iPad stand mount which holds items securely.

Can be quickly and easily mounted on any microphone stand. Proper springs tension the retaining clamps to grip iPad securely. Does not gouge mic stand when clamp is tightened. Multi angle design provides optimal viewing. Will not droop. Metal not plastic stand clamp. Sturdy heavy duty construction throughout.



Description	Code	Price (Ex VAT)
iS-4	449-540	£20.80

iPad Tablet Tripod Grip

8.9" - 10.4"

A unique equipment stand stabiliser that may be used in a variety of ways in Audio, Video, Lighting, and Theatre applications.

- Universal tablet tripod stand for most 8.9" - 10.4" tablets
- Light weight and strong construction
- Flexible legs can be bent to desired shape
- +/-30 tilt, +/-30 swivel, 360 degree rotate
- Material: Plastic
- Colour: Black



Description	Code	Price (Ex VAT)
Tripod Grip	323-080	£14.99

DELIVERY BEFORE 10AM no problem

STANDS
iPhone/iPad + Tablet Stands

CONTINUED

K&M 19712

iPad Holder

A clever way to show off your iPad 2/3/4.

The new mount is guaranteed to hold the iPad effectively and safely. For use on stage, in the rehearsal room or at home - the 3/8" internal thread means the holder can be attached to any microphone stand easily and quickly. The iPad is clipped in and out of the holder effortlessly. An easy-to-use wing nut adjusts the tilt so the user can easily find a position to suit them. The iPad switches rapidly between the vertical and horizontal format without slipping.

To be screwed on to 3/8" threaded bolts. Dock-connector and headphone jack are accessible.



Description	Code	Price (Ex VAT)
19712	478-670	£18.30



K&M 19713

iPad Mini Stand Holder

The mount is guaranteed to hold the iPad Mini effectively and safely.

- For use on stage, in the rehearsal room or at home
- 3/8" internal thread
- The iPad mini is clipped in and out of the holder effortlessly
- An easy-to-use wing nut adjusts the tilt
- Suitable for iPad mini 1st generation
- Lightning connector and headphone jack are accessible



Description	Code	Price (Ex VAT)
19713	488-090	£18.30

K&M 19723

iPad Mini Holder

The clever way to display your iPad Mini.

- Holds an iPad mini securely and comfortably
- Works well on stage, in the rehearsal room or at home
- Strong clamping element with ergonomic clamping screw
- Allows the iPad mini holder to be attached quickly and easily to any tubes up to 30 mm diameter
- Can be screwed on to 3/8" thread connectors



Description	Code	Price (Ex VAT)
19723	488-100	£28.90

K&M 19722

iPad 2/3/4 Holder



The connector holds an iPad 2/3/4 securely and comfortably. The strong prismatic element with its ergonomic clamping screw allows the iPad holder to be attached quickly and easily to any tubes up to 30 mm diameter. The pivoting range is second to none, allowing the user the iPad position of their choice. The swivel movement can be adjusted from free to resistant. Alternatively can be screwed on to 3/8" thread connectors. Dock-connector and headphone jack are accessible.

Description	Code	Price (Ex VAT)
19722	478-680	£28.90

K&M 19740

Tablet PC Holder

Equally suitable for tablets with a protective sleeve or case.

- Suitable for attaching tablet PCs with a height from 120 to 220 mm and a length from 160 to 320 mm
- Adjustable, universal clamping jaw with integrated moss rubber protectors eliminates undesired vibration sound problems
- The adjustable bracket provides extra security
- To be attached to tubes up to 30 mm diameter



Description	Code	Price (Ex VAT)
19740	488-030	£35.80

K&M 19742

Tablet PC Stand Holder

Suitable for attaching tablet PCs in size from 120 to 220mm.

- To be screwed on to 3/8" threaded bolts
- Suitable for tablets in cases or protective covers
- Adjustable clamping jaws
- Freely rotates 90°
- Height from 120 to 220 mm
- Length from 160 to 320 mm



Description	Code	Price (Ex VAT)
19742	488-040	£24.90

K&M 19745

Smartphone Holder

Your smartphone is always within reach with this universal holder.

- Suitable for flat devices, e.g. smartphones or MP3 players with a width of 46 to 76 mm
- The device is released at the press of a button
- Can be freely positioned by means of the 110 mm long holding arm
- To be attached to tubes up to 30 mm diameter
- Operating elements are not impaired in their function



Description	Code	Price (Ex VAT)
19745	488-050	£19.90

iPad Shockproof Case

Silicone shock proof protection case suitable for iPad2 / 3 / 4.

- Integral speaker cut out to project sound to the front
- Ideal for use in the classroom, workplace, home or when out and about travelling



iPad Mini Shockproof Case

Silicone shock proof protection case suitable for iPad Mini.

- Integral speaker cut out to project sound to the front
- Ideal for use in the classroom, workplace, home or when out and about travelling
- Dimensions: 228 x 162 x 32mm
- Weight: 172g approx



iPad Air Shockproof Case

Silicone shock proof protection case suitable for iPad AIR.

- Integral speaker cut out to project sound to the front
- Ideal for use in the classroom, workplace, home or when out and about travelling



Description	Code	Price (Ex VAT)
Shockproof Case	323-040	£7.49
Shockproof Case + Stand	323-070	£8.32
Mini Shockproof Case	323-050	£6.65
Air Shockproof Case	323-060	£8.32

PDF catalogue

Want this catalogue on your phone or laptop?

The Studiospares catalogue is now available in PDF format.

visit www.studiospares.com/page/pdfcatalogue/

MORE PRODUCTS online

SATURDAY DELIVERY no problem

DELIVERY BEFORE 10AM no problem

STANDS

Lecterns

Monacor Speech-200

PA Lectern

A professional lectern with integrated wireless amplifier system built-in and features easy transport and set-up.

- Built-in powerful mixing amplifier and speaker system 75-watts RMS
- Integrated limiter
- 3 inputs via comb. Jack mic (XLR/line) each with 3-way EQ and gain controls
- 1 stereo line input via RCA jacks with gain control
- 2-way speaker system



Description	Code	Price (Ex VAT)
Speech-200	256-430	£582.50
TXS-821HT Handheld	256-450	£49.90
TXS-820LT Handheld	256-460	£55.00
TXS-820SX Handheld	256-470	£58.30

Monacor ETS-840TXS

PA Lectern

A portable lectern conference PA system offering 90-watts of power in white finish.

- Lectern PA with microphone
- Built-in amplifier
- Speaker and wireless microphone
- License free UK radio frequency 863.05Mhz on wireless receiver
- Wireless range: 25m max



NEW LOWER PRICE

Description	Code	Price (Ex VAT)
ETS-840TXS	256-510	£299.17

DID you know?

At Studiospares we process all incoming orders within a few minutes

If anything is to be added to an earlier order, it will be processed as a NEW order.

VISIT our trade counter

You'll get friendly advice and immediate access to 8000+ product lines!

free parking for 40 cars

1000s of products Available from stock!

STANDS

DJ Stands

QTX Lighting Stands

Lightweight Lighting Stand with T-Bar

New lighting stands from Citronic!

A robust Black aluminium lighting stand on a foldable tripod with lockable height adjustment and safety pins. Height 1.5m - 3.5m. Max weight 40kg. T-bar width 1.2m. Weight 3.2kg.

Heavy duty version offers a beefed-up tripod and hence a max weight load of 50kg. Stand weight 4.7kg.

Description	Code	Price (Ex VAT)
Standard Stand	475-660	£35.00
Heavy Duty Stand	475-670	£52.00

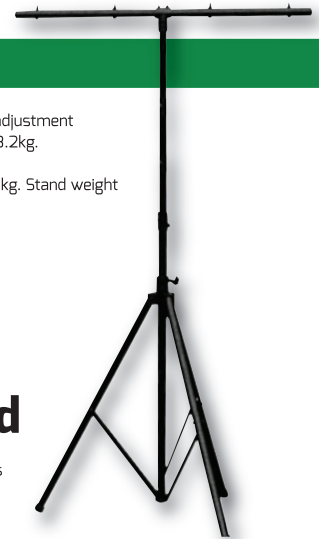

Citronic Lighting Truss Stand

A strong 3m light truss and 2 T-bars with specially strengthened assembly points to increase the maximum load. Can be completely disassembled and is lightweight at only 18kg and easy to erect. Height 1.5 - 3kg. Max weight load 60kg. Weight 16kg.

Description	Code	Price (Ex VAT)
Fixed Extension Arms	475-680	£93.75

CITRONIC

STANDS

Workstations

Proel PJWORK02

Workstation

Designed and structured to satisfy the requirements of both the home and professional audio-video studios.

- Frame made of sturdy steel tubes coated with epoxy powder
- Work surfaces made from MDF coated in a cherry-coloured laminate with PVC edges
- Features two 4 unit 19" rack sections for the placement of electronic equipment
- Retractable sliding shelf for a computer keyboard
- Main work surface is 18mm thick 750mm in length and 610mm in depth



Proel PJWORK03

Workstation

An innovative workstation designed for the home studios made of sturdy construction.

- Features a 6 unit 19" rack section for the housing of electronic equipment
- Retractable sliding shelf for a computer keyboard
- Main work surface is 18mm thick, 1180mm in length, 550mm deep
- Positioned at a height of 790mm
- Top shelf 18mm thick, measures 1180 x 300mm at 1100mm from the floor



Description	Code	Price (Ex VAT)
PJWORK02	477-100	£332.50
PJWORK03	477-120	£227.50

Proel PJW80 12U

Rack Table



The PJW80 companion rack is a 12 unit 19" rack fixture with an epoxy coated tubular steel frame with side protection panels also made of steel. Work surface is made from MDF coated cherry-coloured laminate with rounded edges in PVC. Measures 710mm high, 610mm deep and 530mm wide. Allows the upper level fixture to be coupled with the PJWORK 02 workstation. Construction materials: Steel and MDF.

Description	Code	Price (Ex VAT)
PJW80 12U	477-110	£149.00

WANT a job?

Are you looking for a stable and rewarding career?

Studiospares are constantly expanding. We require additional staff for a variety of positions, working in a very congenial atmosphere. Practical experience of recording and/or live sound engineering would be preferable.

send in your CV in the first instance

INDEX

Instruments	
Guitars	202
Ukuleles	202
Guitar Amps	203
Guitar Pedals	205
Guitar Pedal Accessories	207
Guitar Accessories	207
Tuners + Metronomes	209
Pianos + Synthesisers	210
Keyboard Accessories	211
Drums	212
Drum Accessories	213
Percussion	214
Wind Instruments	214
Stringed Instruments	215

INSTRUMENTS

Guitars

Encore E4

Blaster Bass Pack

The ideal entry to bass playing, with rock solid bass performance, precise tone and superb playing dynamics. Couple to an 'easy-to-get-on-with' feel and first-class instrument balance for a full-size, long scale instrument the E4 bass guitars are your direct access straight into the world of bass playing.

- Encore E4 Bass Guitar
- B.B. Blaster 10 Watt Bass Amp
- Qwik Tune Tuner
- Kinsman Carry Bag and Guitar Stand
- GYC Guitar Lead
- Guitar Tech Guitar Strap
- Encore Tutorial DVD
- Plectrum and Tutor Listing



ENCORE E4

- Vintage style contoured body
- Vintage profile maple neck with rosewood fingerboard 864mm scale length
- Classic design split-coil Guitar Tech pickup
- Fully height-adjustable
- Full-size 3-ply scratchplate
- Chunky 'Elephant's Ear' tuning keys
- Single volume & tone controls with output jack socket
- Strap buttons positioned for perfect balance

Description	Code	Price (Ex VAT)
E4 Sunburst	601-050	£129.00
E4 Black	601-060	£129.00

Palma Junior

Acoustic Guitar Packs

Looking for a guitar suitable for a present or just to give to your young ones to get them started on a six string classical style guitar?

If that is the case, these new Junior Acoustic Guitar Packs are excellent. The 30" Palma classical is perfect for children to start out on.

- Palma Junior Acoustic Guitar
- Handy Carry Bag
- Black Guitar Strap
- Pitch Pipe
- Spare set of strings



Description	Code	Price (Ex VAT)
Palma Junior	601-030	£30.24

Encore Classic Classical Guitar Packs

Encore Classic Guitars have enjoyed a market-leading reputation for many years as the No. 1 choice for student classical instruments. These easy-to-get-on-with guitars are the ideal way to begin learning the exciting skills of playing classical guitar at any age.

Encore ENC440FT

4/4 Size Classic Guitar Pack

- Encore Full Size Classical Guitar
- Guitar Carry Bag
- Encore Set of Strings
- Pitch Pipe
- Tutorial DVD and Tutor Listing

GUITAR SPECIFICATIONS

- Spruce Laminate Top
- Laminate Sides
- Maple Fingerboard
- Maple Neck
- Maple Bridge
- 650mm Scale Length
- Gold/Nylon Roller Machine Heads



Encore ENC340FT

3/4 Size Classic Guitar Pack

- Encore 3/4 Size Classical Guitar
- Guitar Carry Bag
- Encore Set of Strings
- Pitch Pipe
- Tutorial DVD
- Tutor Listing

GUITAR SPECIFICATIONS

- Linden Laminate Top, Back & Sides
- Maple Fingerboard
- Maple Neck
- Maple Bridge
- 590mm Scale Length
- Chrome/Nylon Roller Machine Heads



Description	Code	Price (Ex VAT)
ENC440FT	601-000	£47.83
ENC340FT	601-010	£41.20

Encore Guitar Packs

Encore acoustic and electro-acoustic guitars are expertly constructed, full size, big sounding instruments. They offer a pleasantly crisp and bright tone with an impressive ringing sustain. Responsive and easy to play, they make an ideal instrument to begin learning the guitar. Encore electro-acoustic packs feature a built in Shadow pickup and preamp system, which allows you to plug straight into a suitable amplifier.

Encore W2550FT

Acoustic Guitar Pack

- Encore Acoustic Guitar
- Guitar Carry Bag
- Guitar strap
- Pitch Pipe
- Plectrum
- Tutorial DVD
- Tutor Listing

GUITAR SPECIFICATIONS

- Full Bodied Guitar
- Spruce Laminate Top
- Nato Back, Sides and Neck
- Round Body and Fingerboard
- Rosewood Fingerboard and Bridge
- Compensated Saddle
- 648mm Scale length
- Chrome Diecast Tuners



Description	Code	Price (Ex VAT)
W2550FT	601-120	£73.91

Chord CAL63

Electro Guitar

A traditionally styled standard electric guitar with 3 single coil pickups. The contoured alder body is bolted to the maple neck and fitted with 22 frets into the rosewood or maple fingerboard.

- Bridge has a vintage styled vibrato system
- Controls consist of 2 tones and a master volume with a 5-way lever selector
- Chrome vintage style vibrato bridge
- Scale length 650mm
- Dimensions 330 x 995 x 60mm



Description	Code	Price (Ex VAT)
CAL63 Sunburst	602-840	£82.50
CAL63 Black	602-850	£82.50

Chord CW26CE

Electro-Acoustic Guitar

Steel-strung electro-acoustic guitar with cutaway western style body, spruce laminate top and linden laminate back and sides. Passive under saddle piezo pickup fed via volume and tone controls can be fed to an acoustic amplifier or PA system.

- Fabricated from spruce & linden laminates
- Fingerboard and bridge from rosewood
- Tuning machine heads closed 3 a side
- Scale length 650mm
- 3 gloss finishes. Natural, Sunburst, Black
- Controls, Volume and tone sliders
- Dimensions 1040 x 400 x 125mm



Description	Code	Price (Ex VAT)
CW26CE Natural	602-810	£70.00
CW26CE Sunburst	602-820	£70.00
CW26CE Black	602-830	£70.00

INSTRUMENTS

Ukuleles

Encore VUK20N

Vintage Ukulele Outfit

Comes in an attractively designed brightly-coloured carton and includes a uke Carry Bag, Pitch pipe and felt Pick.

- Mahogany Top & Body
- Rosewood Fingerboard
- 12 Frets
- Rosewood Bridge
- Open Geared Tuners
- Gloss Finish



Description	Code	Price (Ex VAT)
VUK20N	601-040	£25.00

DELIVERY BEFORE 10AM no problem

SATURDAY DELIVERY no problem

INSTRUMENTS

Guitar Amplifiers

Roland Micro Cube GX

Guitar Amplifier

Micro Cube packs a big punch and comes with six DSP effects, COSM® Amp Modeling and a new Digital Tuning Fork.

- Battery or mains powered
- 6x DSP effects: chorus, flanger, phaser, tremolo and separate Delay/Reverb
- Digital Tuning Fork with up to 2 semitones
- Recording/Headphones output and stereo Auxiliary input for CD players, etc.



Description	Code	Price (Ex VAT)
Micro Cube GX	319-070	£90.83

Roland Cube GX

Guitar Amp Range

Powerful new guitar amp range!

A stage and studio-ready combo that steps up the market-leading features and reliability of the original CUBE range. Built for the ambitious musician who demands pro-quality tone for various scenarios, the i-CUBE LINK also provides an onboard audio interface, connecting with iOS devices like the Apple iPhone, iPad and iPod Touch for mobile recording and practice. 3x Channels, JC Clean, Lead and Solo. Solo for saving and recall amp type, EQ and effects settings. 3x FX sections (5 types). Delay and Reverb.

Description	Code	Price (Ex VAT)
20GX 20 Watts	319-040	£132.50
40GX 40 Watts	319-050	£165.83
80GX 80 Watts	319-060	£265.83



Line 6 POD HD500X

Guitar Amp

The world's most advanced guitar systems.

POD® HD500X delivers an incredible combination of powerful features and amazing tone to inspire your creativity. Use your POD HD500X as a MIDI controller, the ultimate audio interface for recording guitar and the center of your performing universe. With cutting-edge technology and all the power you need to define your sound, POD HD500X is the most advanced POD multi-effects—ever. Dynamic DSP lets you stack the amps and effects you want—where you want them—to craft unique new guitar tones or re-create celebrated classics. Provides complete flexibility, providing all the ins and outs you need to connect your stage equipment and record in the studio. With StageSource L2m, you've got a cutting-edge, full-range, flat-response guitar system that delivers consistent tone at any volume—from studio to rehearsal, to the gig.

Description	Code	Price (Ex VAT)
POD HD500X	301-780	£357.50



Line 6 Spider IV 15/30

Guitar Amp

Spider® IV amplifiers deliver best-selling rock star tones. Industry-leading Line 6 amp and FX modelling, dialed-in tones and presets, and much more.

- 15W or 30W models
- 4 / 12 amp models
- 6 / 7 Smart FX



Line 6 Spider IV 75

Guitar Amp

Spider IV with 75W custom Celestion speaker.

- 16 amp models
- 20 Smart FX
- Headphone/Direct Out
- CD/MP3 jack
- FBV jack
- Built-in front panel chromatic tuner



Description	Code	Price (Ex VAT)
Spider IV 15	301-000	£70.00
Spider IV 30	301-010	£132.50
Spider IV 75	301-020	£216.66

Line 6 Amplifi

Hybrid Stereo Guitar Amp

The world's only full-range guitar amp and wireless speaker system.

- Combines amazing sound with a groundbreaking mobile app
- AMPLIFI Remote for iOS and Android™ brings the guitar experience to your digital life
- Wirelessly stream your favorite tracks from any Bluetooth enabled device directly to AMPLIFI
- 5-way full-range stereo speaker system
- Built-in DSP provides amazing-quality tones and effects
- Available in powerful 150-watt model or portable 75-watt version



Description	Code	Price (Ex VAT)
Amplifi 150W	301-790	£315.83
Amplifi 75W	301-800	£249.17

Roland Mobile Cube

Portable Amplifier

Small and mighty, this little stereo amp can handle all types of electronic instruments and audio devices, and can be used anywhere, anytime.

- 5W (2.5W + 2.5W) stereo power with two high-performance 10cm (4") speakers
- Inputs for mic, stereo-instrument, and stereo AUX; headphone output
- Stereo reverb/chorus, distortion etc



Description	Code	Price (Ex VAT)
Mobile Cube	309-730	£104.17

BB Blaster Guitar Combo

10W Guitar Amplifier

10 watt guitar amplifier, designed for performance and simplicity.

- Standard 1/4 inch Jack input
- Distortion control simply increases or decreases distortion
- Overall tone control changes the relationship between low, mid and high frequencies
- Headphone output mutes the internal speaker



BB Blaster Bass Guitar Combo

10W Bass Guitar Amplifier

Compact 10 watt bass guitar amplifier with gain, treble, bass and volume controls

- 8" speaker in a robust speaker cabinet with closed-back construction
- Standard 1/4 inch Jack input
- 3-band rotary control EQ system
- Headphone output mutes the internal speaker



Description	Code	Price (Ex VAT)
Blaster	601-300	£35.00
Blaster Bass	601-310	£42.30

MORE PRODUCTS online

1000s of products Available from stock!

VISIT our trade counter You'll get friendly advice and immediate access to 8000+ product lines!

INSTRUMENTS

Guitar Amplifiers

CONTINUED

Bugera 333XL-Infinium

Electric Guitar Head

120-watt 3-channel tube amplifier head with reverb.

- Big brother of the 333 series with four key additions
- Presence Control
- Loaded with EL34 power tubes for more compressed midrange
- Analogue noise gate on lead channel
- XL switch on Crunch and Lead channels



Bugera 333XL-212-Infinium

Electric Guitar Combo

Hand-built 120-watt Guitar Combo driven by 4 x EL34 tubes (convertible to 6L6).

- Big brother of the 333 series with four key additions
- Loaded with EL34 power tubes for more compressed midrange
- Analogue noise gate on lead channel
- XL switch on Crunch and Lead channels



Description	Code	Price (Ex VAT)
333XL-Infinium	383-720	£299.00
333XL-212-Infinium	383-730	£415.83

Bugera 6262-Infinium

Electric Guitar Head

Built on the same fundamentals as the 6260 with more midrange.

- For 80's rock and metal
- 120-watt 2-channel tube combo
- Full independent EQ controls, Presence and Reverb on both channels
- Hand-built 120-watt amplifier driven by 4 x 6L6 tubes (convertible to EL34)
- Revolutionary Infinium Tube Life Multiplier Technology



Bugera 6262-212-Infinium

Electric Guitar Combo

120-watt 2-channel tube combo with reverb for Rock and Metal.

- 2 Original 12" BUGERA guitar speakers optimized for tight low-end and modern -vintage mids
- 2-channel preamp design featuring 6 x 12AX7 tubes
- Integrated high-class reverb with dedicated controls for each channel



Description	Code	Price (Ex VAT)
6262-Infinium	383-740	£365.00
6262-212-Infinium	383-750	£415.83

Bugera V22

Valve Guitar Combo

Possesses modern features and also exudes a vintage sound.

The V22 is a stunning 1 x 12" combo that not only exudes vintage sound, but also possesses modern features that will launch your tone into the sonic stratosphere. Ideal for practice, home recording, and even small club gigs, this loud lad channels its output through two EL84 tubes, providing the bratty, breakup-prone power tube compression that 6L6GC-equipped amps typically only achieve at extreme volume levels. The V22's sound begins with a two-channel (Clean and Lead) preamp. Tone-sculpting options abound, including an onboard 3-band EQ (Bass, Mid, Treble) with Presence control and Mid Boost. The preamp's three 12AX7 tubes ooze warmth, creating vintage and modern tones that range from clean to dignified blues to garage-leveling madness.



Bugera V5

Valve Guitar Combo

Dressed in classic two-tone vinyl with a vintage look and feel.

The BUGERA V5 delivers a sound that's caked in real vintage tube tone. But it also has modern features that will take your sound to places it couldn't go – until now. The V5's attenuator provides saturated tube tone at 1, 5 or 0.1 Watts, allowing you to rock out without disturbing the neighbors. It even has a headphone jack for completely private practice. But when public mayhem is on the agenda, you can use the SPEAKER OUT jack to drive a BUGERA 4 x 12 cabinet! Add a dash of built-in reverb and you've got a versatile vintage-voiced powerhouse that you can carry in one hand. From the bedroom to the studio to the gig, the BUGERA V5 has you covered.



Description	Code	Price (Ex VAT)
V22	383-780	£224.17
V5	383-790	£120.83

Bugera

Bugera V55

Valve Guitar Combo

Captures the stunning sound of the 1960's.

- 55W vintage 2-channel tube combo
- Features a road-tough footswitch that allows you to select channels & activate/kill the reverb remotely
- Impedance switch (4,8 & 16 ohms)
- Also available in a head version, V55HD
- Triode mode for urgent, aggressive tonal edge
- Pentode mode for clean sound



Description	Code	Price (Ex VAT)
V55	383-760	£262.50
V55HD	383-770	£199.00

Bugera 412H-BK/412F-BK

Guitar Cabinet

Offers explosive power and vintage tone perfect to complement all Bugera valve heads.

- Switchable 200W, 16-Ohm or 2 x 100W, 8-Ohm stereo mode operation
- Recessed carrying handles and rollers for easy transportation
- Extremely low-resonance and low vibration cabinet
- Reinforced corners and protective vinyl covering



Description	Code	Price (Ex VAT)
412H-BK	383-800	£157.50
412F-BK	383-810	£157.50

Bugera BVP5500

Bass Head



Offers valve gain control and 9-band graphic equalizer.

- Powerful 550-watts valve bass amplifier head for classic sound and performance
- 4 x 12AX7 valves give you the ultimate sound and feel only valves can provide
- Switchable ultra-low and ultra-high function for ultimate tone
- Effects loop for external effects devices
- Valve gain control

Description	Code	Price (Ex VAT)
BVP5500	383-820	£249.99

FOR
fax orders
Use our fax number...
020 8450 4390

PDF catalogue
Want this catalogue on your phone or laptop?
The Studiospares catalogue is now available in PDF format.
visit www.studiospares.com/page/pdfcatalogue/

SATURDAY DELIVERY
no problem

Behringer V-AMP 3

Virtual Guitar Amplifier

The Behringer V-AMP3 Virtual Guitar Amplifier includes a USB Audio Interface.

- 32 amp models, 15 speaker cabinet models and 16 stereo effects
- 125 memory locations with 50 presets
- MIDI connections and USB interface
- Stereo Aux input for play along practice
- Stereo balanced jack outputs and headphone output.
- Gig bag and dual footswitch
- Chromatic tuner



NEW LOWER PRICE

Description	Code	Price (Ex VAT)
V-Amp 3	382-410	£61.00

Behringer Bass V-Amp Pro

Bass Guitar Amplifier



The 19" rackmount version of the Bass V-Amp with extensive MIDI and digital connectivity.

- 32 amp models, 23 Speaker cabinet models and 16 effects
- Rack-mountable with three-band EQ, gain, volume, master volume, presence, tap and compressor controls.
- 125 memory locations including presets
- Stereo multi-effects
- Crossover for bi-amping operation
- Auto-chromatic tuner
- 15 rear panel connectors including DI out
- Wordclock, AES/EBU and Midi connections

Description	Code	Price (Ex VAT)
Bass V-Amp Pro	370-350	£104.17

Behringer ACX1800/ACX900

Acoustic Guitar Amp

This is an acoustic instrument combo amplifier from Behringer with dual FX and FBQ feedback detection system.

- The ACX1800 and ACX900 are 180watts and 90watts respectively
- Both features 2 original 8" Bugera dual-cone speakers for ultimate sound reproduction
- 2 integrated, 24-bit FX processors
- FBQ Feedback Detection system



Description	Code	Price (Ex VAT)
ACX1800	383-660	£207.50
ACX900	383-670	£165.80

Behringer VT100FXH

Guitar Amp

This is a powerful 100-watt, 2-channel guitar amplifier head with authentic VTC tube modeling.

- VTC virtual tube circuitry
- Dual digital FX processors with chorus/delay, chorus, flanger, delay plus separate reverb
- 2 full-featured channels
- 2 switchable modes on each channel
- Includes footswitch for channels and FX bypass



Description	Code	Price (Ex VAT)
VT100FXH	383-680	£119.50

Guitar Pedals

INSTRUMENTS

Behringer X V-AMP Amp-Pedal



NEW LOWER PRICE

Floor-based amp pedal unit...

The X V-AMP not only features the best V-AMP models of celebrated guitar amplifiers and speakers, but also provides simulations of the most desirable guitar effects combined with a multi-mode expression pedal. A special acoustic simulation and an amp bypass function are also included. Power supply included. More info online.

Description	Code	Price (Ex VAT)
X V-Amp	370-930	£37.50

Boss VE-20

Vocal Performer Pedal

Designed from the ground up for singers offering some of the finest vocal-effects technology on the market.

- Footswitch operation to add lush vocal layers and harmonies to your singing
- Double-track, dynamics, reverb, delay and more
- Create the total of 3-part harmonies and layers
- Realtime pitch-correction tools
- Special FX, Phrase looper & phantom power for condenser microphones



Description	Code	Price (Ex VAT)
VE-20	309-770	£165.83

Line 6 FBV Express MkII

Guitar Pedal

Stomp the four steel footswitches to quickly store and select channel presets, synchronize your time-based effects with Tap Tempo, activate the chromatic tuner, and more.

- 4 channel switches: A, B, C and D
- FBV Control software for easy and unlimited mapping of FBV controls via USB (Mac@/PC)
- Bright LEDs show active channel, tap tempo and volume/wah
- Self-powered via included locking RJ-45 cable



Description	Code	Price (Ex VAT)
FBV Express MkII	301-550	£70.83

Behringer PB1000

Pedal Board

Universal effects pedal floor board with integrated power supply.

- Ultra-compact and lightweight
- Transports up to 12 effects pedals
- 1.7 A power adapter included
- Ultra-rigid plastic design
- High-quality components and rugged construction



NEW LOWER PRICE

Behringer PB600

Pedal Board

Universal effects pedal floor board with a 9V DC Power Supply and patch cables.

- Houses a generous 1.7 amp power adapter for powering more than 12 devices
- 1x6 daisy chain cabling
- Please note guitar pedals are not included



Description	Code	Price (Ex VAT)
PB1000	382-120	£72.50
PB600	382-420	£57.50

Boss RC30

Loopstation

A twin pedal multitrack looper with two synchronized stereo tracks and built-in loop effects.

- Plug in an instrument or microphone and record for up to three hours direct to internal memory, adding effects as you go
- Dedicated volume faders and track-select buttons; 99 memory phrases



NEW LOWER PRICE

Boss RC3

Loopstation

The RC-3 is powerfully equipped yet compact. Enjoy up to three hours of stereo recording time, storage for 99 loops, a "real drums" rhythm guide, and USB 2.0 compatibility.

- Massive internal memory with up to 3 hours of stereo recording time
- Import/export WAV audio
- 99 memories for storing loops



NEW LOWER PRICE

Boss RC-300

Loopstation

Boss claim the RC-300 is the most powerful Loop Station ever brought to the market.

- Three stereo tracks with dedicated footswitches and faders
- 16 onboard effects optimized for looping with a real-time control pedal
- 3 hours recording; 99 memories
- XLR Microphone input with phantom power



NEW LOWER PRICE

Description	Code	Price (Ex VAT)
RC30	309-550	£165.83
RC3	309-560	£115.83
RC-300	309-720	£332.50

no problem SATURDAY DELIVERY

no problem DELIVERY BEFORE NOON

INSTRUMENTS

Guitar Pedals

CONTINUED

Behringer DD400

Digital Delay

Offers subtle to radical stereo delay and echo.

- Real Sound Modeling
- 24-bit high-resolution stereo effects
- Dedicated peak, range, sensitivity, filter and polarity controls
- Blue status LED for effect on/off and battery check
- Runs on 9 V battery or the BEHRINGER PSU-SB DC power supply (not included)



Description	Code	Price (Ex VAT)
DD400	382-050	£27.50

Behringer DR600

Digital Reverb Pedal

Sounds rich, textured and realistic at every setting.

- Ultimate digital reverb effects pedal comparable to state-of-the-art studio processors
- 24-bit high-resolution stereo reverbs
- Dedicated Mode, Time, Tone and Level controls
- Blue status LED for effect on/off and battery check



Description	Code	Price (Ex VAT)
DR600	381-810	£27.50

Behringer DR400

Digital Reverb Pedal

Digital reverb effects pedal comparable to state-of-the-art studio processors.

- Real Sound Modeling (RSM)
- 24-bit high-resolution stereo effects
- Dedicated mode, reverb/delay time, tone/feedback and balance controls for awesome sound shaping
- Blue status LED for effect on/off and battery check



Description	Code	Price (Ex VAT)
DR400	381-820	£29.90

Behringer BSY600

Bass Synthesizer

Offers real sound modeling with sophisticated algorithms to emulate real acoustic environments.

- With 11 saw, square and pulse synth waveforms, control filter cutoff and LFO
- Dedicated mode, decay/rate, resonance, direct, effect and frequency controls
- Reproduces fat and powerful classic analogue synth sounds at a touch of a footswitch
- Status LED for effect on/off and battery check
- Runs on 9V battery or the Behringer PSU-SB DC power supply (not included)



Description	Code	Price (Ex VAT)
BSY600	383-650	£27.00

Roland ME80

Guitar Effects Unit

The ideal processor for any performing guitarist.

The Boss ME-80 takes the features of the previous ME-70 pedal, updates them and then adds the key features from the flagship GT-100, making it as packed with tones and features as any top-line recording studio. However, thanks to its simple user interface, the ME-80 is no harder to use than a single stompbox. The Boss ME-80 comes equipped with an amazing array of ultra-realistic COSM amp models that replicate some of the most desirable amplifiers in history and allow for a wide range of tones to be dialled in with the greatest of ease. A massive selection of pro-level effects are also readily available, ranging from classic Boss distortion and overdrives to the most modern MDP effects. Thanks to its pedalboard-style layout, the ultra-intuitive controls and expression pedal of the ME-80 multi effects allow for any tone to be selected and shaped incredibly quickly. This makes it the ideal implement for any live guitarist, but thanks to the included Boss Tone Studio software, it's also indispensable in the studio as well.



NEW

Description	Code	Price (Ex VAT)
ME80	319-120	£224.17



Behringer RV600

Reverb Machine

The RV600 contains Behringer's Real Sound Modeling processor and DSP technology, giving it the power to make your guitar sound like you're playing in a cave, a cathedral, or even the outer reaches of the cosmos.

- Reverbs from Spring, Plate, Room, Hall, Ducking, Echo to Space sounds
- Dedicated Mix, Decay, Time, Type, Tone and Trails controls for sound shaping



Description	Code	Price (Ex VAT)
RV600	383-290	£29.90

Behringer EQ700

Graphic Equaliser

Shape your sound effortlessly and eliminate feedback with 7 EQ bands.

- Frequency range from 100Hz to 6.4kHz
- powerful 15dB boost/cut per band
- Status LED for effect On/Off and battery check
- Runs on 9V battery or the DC power supply (not included)



Description	Code	Price (Ex VAT)
EQ700	380-540	£18.32

Behringer AB100

Guitar/Amp Selector

Can easily be used to switch between instruments, amplifiers, effects and other gear.

- Super-flexible 2-mode selector
- musicians who want to switch instruments fast can toggle between two input signals to one output or vice-versa switch between two guitars using one amplifier or two amplifiers with one guitar



Description	Code	Price (Ex VAT)
AB100	380-600	£18.32

Behringer T0800

Vintage Tube Overdrive

Features the classic sound of blazing, overdriven vacuum tubes.

- Vintage tube-like tone
- Uses the original 4558IC plus MA159 distortion diodes for authentic vintage sound
- Dedicated drive, tone and level controls for sound shaping
- Status LED for effect on/off and battery check



NEW LOWER PRICE

Description	Code	Price (Ex VAT)
T0800	383-620	£12.00

Behringer NR300

Filter Machine

Two pedals in one ultimate noise reducer effects pedal.

- Eliminates unwanted noise and hum without altering your tone
- Preserves the original attack and envelope while leaving your playing and dynamics intact
- Dedicated threshold and decay controls
- Additional send/return loop for noise suppression of external effects units



NEW LOWER PRICE

Description	Code	Price (Ex VAT)
NR300	383-370	£15.00

Behringer VD400

Vintage Delay

True analogue delay and vintage slap-back echo.

- Dedicated echo and repeat rate controls
- Blue status LED for effect on/off and battery check
- "Old school" like analogue Bucket Brigade-style delay
- Low price tag
- Vintage BBDs produce up to 300ms of delay and advance noise reduction circuit



NEW LOWER PRICE

Description	Code	Price (Ex VAT)
VD400	383-630	£15.00

Behringer VM1

Vintage Time Machine

The Vintage Time Machine VM1 effects pedal features a great combination of classic effects that have stood the test of time.

- Dedicated Delay, Chorus/Vibrato, Feedback, Mix and Level controls for awesome sound shaping
- Up to 550 ms of organic echo to rival any tape delay, vibrant chorus and mind-bending vibrato
- True hard-wire bypass



NEW LOWER PRICE

Description	Code	Price (Ex VAT)
VM1	383-270	£29.99

Zoom G10N/G1XON

Guitar Effects Processor

Everything today's guitarist needs.

- Allows you to choose from 100 different onboard DSP effects, including distortion, compression, modulation, delay and reverb
- Up to 5 effects can be used simultaneously
- 100 memory locations (10 banks of 10)
- 68 built-in rhythm patterns
- Onboard chromatic tuner
- The G1Xon offers 5 additional pedal-controlled effects with a built-in expression pedal



NEW

Description	Code	Price (Ex VAT)
G10N	377-890	£40.83
G1XON	377-900	£54.17

Zoom B10N/B1XON

Bass Guitar Effects Processor

Everything today's bassist needs.

- Allows you to choose from 100 different onboard DSP effects, including distortion, compression, modulation, delay and reverb
- Up to 5 effects can be used simultaneously
- 100 memory locations (10 banks of 10)
- 68 built-in rhythm patterns
- Onboard chromatic tuner
- The B1Xon offers 5 additional pedal-controlled effects with a built-in expression pedal



NEW

Description	Code	Price (Ex VAT)
B10N	377-910	£40.83
B1XON	377-920	£49.17

Guitar Pedal Accessories

INSTRUMENTS

Behringer PSU-HSB-ALL

DC Power Adaptor

All-country DC 9 V / 1.7 A power adaptor.

- Powers more than 20 effects pedals, keyboards and other DC 9V gear
- Supplied with a full complement of connectors and jumper cords
- Includes 4 assorted jumper cables and 2 daisy-chain cables each with 5 connectors
- Takes up only one outlet space



NEW LOWER PRICE

Behringer PSU-SB 9V

DC Power Adaptor

A DC 9V power adaptor to power virtually all your guitar or bass guitar stomp boxes and effects pedals.

- Provides a generous 100mA current to power even digital products
- DC-type 2.2mm plug with negative tip and positive sleeve
- High quality components and exceptionally rugged construction



NEW LOWER PRICE

Description	Code	Price (Ex VAT)
PSU-HSB-ALL	382-140	£20.83
PSU-SB 9V	382-150	£8.33

Diago Powerstation

Pedal Board Power Supply



The Diago Powerstation is the ultimate pedal board power supply. It will power from 1 to 30 pedals without noise or hum. Most pedal power supplies are transformer type, linear regulated designs, which are cheap to design and develop, but are expensive to make and therefore buy. Cheaper power supplies are usually underrated, unregulated, poorly filtered designs and more expensive power supplies are often engineering marvels, but there really is no need and they cost far too much. However the Diago Powerstation solves all these nuances and is not only great value but great quality too. It uses digital switch mode technology, making it quiet, light, efficient and small, reliably powering your pedals so you can concentrate on making music.

Description	Code	Price (Ex VAT)
Power Station	602-300	£51.90

Accessories

Description	Code	Price (Ex VAT)
Deluxe Daisy Chain Connector	602-310	£8.69
Green Adaptor	602-320	£5.21
Blue Adaptor	602-330	£5.21
Red Adaptor	602-340	£5.21
White Adaptor	602-350	£5.21
Black Adaptor	602-360	£5.21

QTX Power Bank 9V DC

Housed in a robust ABS plastic case, this is a power bank for simultaneous connection of up to 10 effects pedals.

- 2.1mm DC sockets with negative centre polarity
- An on/off power switch with integral LED
- Supplied with ten 280mm DC-DC power leads and mains adaptor.



Description	Code	Price (Ex VAT)
Power Bank 9V DC	475-780	£29.70

INSTRUMENTS

Guitar Accessories

Encore Guitar Strings



The Encore range of guitar strings are both popular and reliable. 10 varieties. The Electric, Bass and Acoustic sets are round wound and the Classical set is nylon.

Description	Code	Price (Ex VAT)
Electric x 6 Nickel - Light 9s	407-610	£3.59
Electric x 6 Nickel - Med 10s	407-620	£3.59
Bass x 4 Nickel - .040"	407-630	£8.74
Bass x 4 Nickel - .045"	407-640	£8.74
Acoustic x 12 Silver - Ex Light	407-650	£5.90
Acoustic x 12 Silver - Light	407-660	£5.90
Acoustic x 6 Silver - Ex Light 10s	407-670	£3.90
Acoustic x 6 Silver - Light 12s	407-680	£4.60
Acoustic x 6 Silver - Med 13s	407-690	£3.90
Classical x 6	407-700	£3.65

Yamaha Guitar Strings

Yamaha Guitar strings are generally considered to be amongst the finest available.

Electric Strings

	Description	Code
EN09	Super light, Nickel Wound 009, 011, 016, 024, 032, 042	264-610
EN10	Light Nickel Wound 010, 013, 017, 026, 036, 046	264-620

Bass Strings

	Description	Code
H4050	5 String, stainless steel, 045, 065, 085, 105, 125	264-670
H4070	6 String, stainless steel, 035, 045, 065, 085, 105, 125	264-680

Description	Code	Price (Ex VAT)
EN09	264-610	£5.17
EN10	264-620	£5.17
H4050	264-670	£19.60
H4070	264-680	£23.20

1000s
of products
Available from stock!

VISIT
our trade counter

You'll get friendly advice and immediate access to 8000+ product lines!

SATURDAY DELIVERY
no problem

DELIVERY BEFORE 10AM
no problem

ALL PRICES EXCLUSIVE OF VAT.

INSTRUMENTS

Guitar Accessories

CONTINUED

Shubb Capo

Once the serious guitarist has discovered the Shubb, they'll never settle for anything less.

- Patented locking action
- Doesn't create tuning problems
- Soft, resilient rubber
- Available in brass, silver and black



Shubb Capo Deluxe

Everything the original Shubb capo is, and more!

- Stainless steel resists wear and nicks
- Restyled lever is easier to handle
- Roller reduces wear, while adding smoothness to the opening and closing action
- Closing action is more uniform



Description	Code	Price (Ex VAT)
Capo Silver/Black	450-960	£18.70
Capo Brass	450-970	£16.59
Capo Deluxe	450-980	£21.30

Guitar Tech GT301

Guitar Strap



Standard black nylon web strap, 2" (50mm) width, genuine stitched leather end pieces.

Guitar Tech GT314

Guitar Strap



Black leather, 2 1/2" wide with multi star stud design, lined.

Description	Code	Price (Ex VAT)
GT301	601-940	£2.76
GT314	601-950	£9.55

Acoustic/Electric Capo

Acoustic/electric guitar capo.

- Material: zinc alloy
- Fast and easy to operate
- Clamps on any fret
- No adjustments required
- Colour: Black



Description	Code	Price (Ex VAT)
Acoustic/Electric Capo	602-970	£3.75

Diago Angled Patch Plug

Patch Plug

As supplied with the Solderless Kit.

- No soldering required
- Cut the cable, push it into the plug and screw on the cap with a coin



Description	Code	Price (Ex VAT)
Angled Patch Plug	602-690	£3.90

Diago Patchfactory Kit

Solderless Plug Kit

The Diago Patchfactory allows you to build custom length patch cables, without additional tools or specialist skills.

- Set of 10 Jack Connectors and a knife
- Assembled with the knife and a coin
- Enough cable and plugs to make 5 leads
- Low loss cable maintains the high frequencies



Description	Code	Price (Ex VAT)
Patchfactory Kit	602-680	£53.90

Guitar Clip-On Pickup

Guitar DI-Box Function

Able to pick up the original tone of your guitar regardless of any background noise.

- Designed for clipping in the sound hole
- Moulded 6.3mm jack plug
- Lightweight flexible cable



Description	Code	Price (Ex VAT)
Pickup	475-740	£7.95

USB Guitar Link Cable Interface

Simply plug in your guitar and turn your PC or Mac Computer in to a guitar amp.

- Works directly with PC or Mac computer, ultra-Low latency driver for PC included.
- High-quality components and exceptionally rugged construction ensures long life.
- Easy Plug and Play Installation.
- Variable-speed file playback function for MP3, WAV, AIFF audio files, perfect for easy learning and practicing
- USB bus powered, requires no external power



Description	Code	Price (Ex VAT)
Guitar Link Cable Interface	602-980	£12.49

Dunlop Tortex Standard

Plectrum

This is a top quality plectrum.

- Carefully designed and manufactured
- Gives the same characteristic of maximum memory and minimum wear that made original tortoise shell famous



Dunlop Nylon Standard

Plectrum

High quality pick.

- Moulded nylon 0.73mm pick
- Available in 2 colours, grey and dark grey



Description	Code	Price (Ex VAT)
Tortex 0.73mm Yellow	602-420	£0.52
Tortex 0.88mm Green	602-430	£0.52
Tortex 1.14mm Purple	602-440	£0.52
Nylon 0.73mm Grey	602-450	£0.52
Nylon 0.73mm Dark Grey	602-460	£0.52

Dunlop Picks Pack of 6

Guitar Picks

Four colours.

- These picks are very popular with jazz players
- Pack of 6



Description	Code	Price (Ex VAT)
Jazz III Pick Red x6	602-710	£5.34
Jazz III Pick Black x6	602-720	£5.34
Jazz III XL Pick Red x6	602-730	£5.46
Jazz III XL Pick Black x6	602-740	£5.46
Ultex Jazz III Pick x6	602-750	£5.10
Petrucci Jazz III Pick x6	602-760	£5.70

Dunlop Electric Guitar Strings

Nickel Plated Steel

NEW



A unique combination of crisp highs, aggressive mids, and a focused low end gives Dunlop Electric Guitar Strings a voice all their own. Responsiveness produces string sets that are perfect for dynamic lead work, while notes in a chord ring out clearly whether clean or heavily distorted. This powerful voice is delivered in a low tension string with a smooth tactile feel that breaks in fast and lasts a long time. Warm and clear tone. Smooth tactile feel, Low tension, Long lasting.

Description	Code	Price (Ex VAT)
Light/Heavy x6	602-940	£4.99
Medium x6	602-930	£4.99
Heavy x6	602-950	£4.99
Light x6	602-920	£4.99

Ukulele Strings

Set of 4

High Performance Strings Gives super tone.

- Set of 4 strings comprising of:
 - Concert / Inch / Tension (kg)
 - 1 / .024 / 4.1kg
 - 2 / .031 / 3.5kg
 - 3 / .037 / 3.3kg
 - 4 / .026 / 3.7kg



Description	Code	Price (Ex VAT)
Ukulele Strings x 4	602-990	£3.75

Precision Guitar Tool Kit

No guitarist should be without one.

- Hardened steel hex wrenches (1.5 mm, 2.5 mm, 3 mm, .050 hex)
- Phillips head screwdriver
- Flat head screwdriver
- Bridge pin puller.
- Carbide steel blade cuts all strings, even bass strings



Description	Code	Price (Ex VAT)
Guitar Tool Kit	438-900	£19.70

Dunlop Premiere Acoustic Nylon Standard

Guitar Strings x6

Designed to achieve tonal balance, smooth tactile feel, and the wide dynamic range required by classical guitarists.

- Feature a high grade silver-plated copper wrap surrounding a nylon core
- Made of Dupont Tynex® for consistency, ease of tuning, and a warm but singing tone
- Packaged utilising three levels of moisture protection and sealed in a VCI Fresh Technology (Vapor Corrosion Inhibitor) bag



Description	Code	Price (Ex VAT)
Standard Guitar Strings x 6	602-910	£5.82

Dunlop Premiere Acoustic Nylon Strings

Guitar Strings with Ball Ends x6

Designed to achieve tonal balance, smooth tactile feel, and the wide dynamic range required by classical guitarists.

- Bass Strings feature a high grade silver-plated copper wrap surrounding a nylon core
- Articulate bass, focused midrange and clear treble response
- Smooth and balanced tactile feel Long life
- Three levels of moisture protection and sealed in a VCI Fresh Technology bag

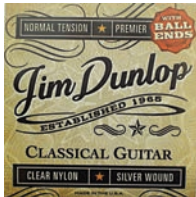

Description	Code	Price (Ex VAT)
Ball End Guitar Strings x 6	602-900	£6.66

Mic Stand Pick Holder 7"

This Mic Stand Pic Holder is a must for every performing musician.

- Made of high quality rubber to ensure a firm hold



Description	Code	Price (Ex VAT)
Pic Holder 7"	602-470	£5.50

Guitar Cabinet Mic Clamp

A firm and secure holding mechanism.

- Fits cabinets 200 mm to 355 mm deep
- Gooseneck length 240 mm
- Rugged stainless steel construction
- Holds mics up to 0.6 kg
- Microphone and holder shown not included



Description	Code	Price (Ex VAT)
Mic Clamp	460-290	£32.50

IK iRig Stomp Guitar

Guitar Interface

The iRig is the first stomp box guitar interface for the iPhone, iPod touch and the iPad.

- Based on the popular AmpliTube iRig interface
- Compatible with any iOS guitar/amp/instrument app
- Compact, durable and lightweight
- Can be used in line with other effects pedals or direct to amps and PA systems
- FREE AmpliTube iOS app



Description	Code	Price (Ex VAT)
Stomp Guitar Interface	321-540	£32.50
Guitar/Bass Interface	321-560	£20.82

Guitar Pick Holder

Silvered plastic holder for plectrums with spring loaded retainer and self-adhesive backing.

- Backing adhesive will not spoil surface
- Reliable plectrum securing mechanism
- Looks smart
- Dimensions 32 x 36 x 11 mm



Description	Code	Price (Ex VAT)
Pick Holder	602-790	£1.95

Kinsman AC Mains Pedal Adaptor

9V

Kinsman AC Power Adaptor for 9V Pedal Systems.

- Standard center negative 2.1mm tip
- 500ma stomp box power adapter
- 1.8m cord length
- 3 pin uk plug
- Lightweight



Description	Code	Price (Ex VAT)
Mains Pedal Adaptor 9V	602-960	£4.99

Korg GA40

Black Tuner

A compact tuner designed specifically for guitar and bass, with excellent performance and convenient functionality.

- Quinta-flat tuning mode allows dropped tunings from one to five semitones
- Supports tuning of seven-string guitars and six-string basses
- Sound out function lets you produce a reference tone from the internal speaker
- Bypass and Auto power off function



Description	Code	Price (Ex VAT)
GA40	273-690	£11.66

Korg MA1

Metronome

The new standard in compact metronomes available in your choice of colours.

- Multi-function compact metronome
- Available in two colour schemes: black and red, or blue and black
- Enhanced display makes it easier to practice your rhythm and phrasing
- Doubles as a chromatic tuner
- Memory backup and up to 290 hours of continuous use



Description	Code	Price (Ex VAT)
MA1	283-200	£9.02

Korg Dolcetto AW-3M

Orchestral Clip-On Tuner

Comprehensive support for large or small orchestral instruments.

- Large clip that can be attached to a range of orchestral instruments
- Adjustable through a wide range of 360° rotation and 180° forward/backward motion
- Metronome and tuner function
- LCD meter with a high-brightness white backlight



Description	Code	Price (Ex VAT)
Dolcetto AW-3M	273-680	£24.99

INSTRUMENTS

Tuners + Metronomes

Behringer TU300

Tuner

The TU300 stomp box offers you a quick and easy way to tune your guitar.

It gives you comprehensive tuning capabilities when you're on stage or in the studio. This tuner gives you 7 different tuning modes including Regular, Flat, Double Flat and Chromatic mode. The TU300 features a precise single-digit LED display and 11-point Stream Meter which ensure accurate tuning. A cool blue status LED for effect on/off and battery check plus a first-class electronic on/off switch for highest signal integrity in bypass mode are included. The TU300 runs on a 9 V battery or a DC power supply (not included).

Description	Code	Price (Ex VAT)
TU300	381-650	£18.32



VISIT
our trade counter

You'll get friendly advice and immediate access to 8000+ product lines!

free parking for 40 cars

SATURDAY DELIVERY
no problem

DELIVERY BEFORE 10AM
no problem

INSTRUMENTS

Tuners + Metronomes

CONTINUED

TC Electronic Polytune

Poly-Chromatic Tuner

Tune all the strings on your guitar or bass at the same time!

- Powered by battery or external 9v DC power supply
- Stores pitch reference and tuning mode settings
- Allows for dropped tunings from E-flat all the way down to B



Description	Code	Price (Ex VAT)
Polytune	386-460	£60.00

Boss TU-80

Tuner + Metronome

The Boss TU-80 brings super-accurate LCD tuning to a very affordable price, while adding unique features like a built-in metronome and Accu-Pitch.

- Supports chromatic tuning, plus 7-string guitars and 6-string basses
- Accu-Pitch function sounds a tone when tuning is complete
- Memory function stores tuner settings



Description	Code	Price (Ex VAT)
TU-80	309-650	£15.83

Tuner and Chord Computer

An effective Pocket tuner with large LCD display and backlight.

- Tuning mode is guitar, bass or chromatic
- Adjustable A4 frequency from 435-445Hz
- Internal 240 chord library can be selected by root note and type
- Tuning range A0 (27.5Hz) - A8 (4186.0Hz)



Description	Code	Price (Ex VAT)
Tuner and Chord Computer	602-800	£16.50

Behringer Racktuner BTR2000

Racktuner



Multi-functional tuner with a built-in microphone.

- Offers 11 different tuner modes
- Manual or automatic A-tone standard pitch calibration from 428Hz to 452Hz in 1Hz increments
- 2 separate input channels accessible via front and back connectors
- Adjustable metronome from 30 to 240bpm
- Integrated, switchable rack light with LEDs
- Manual TAP tempo function ONLY

Description	Code	Price (Ex VAT)
BTR2000	380-320	£55.50

Backlit Clip-On Tuner

Tuner

A clip-on chromatic tuner with built-in contact transducer and microphone.

- Backlit LCD displaying clip or mic, note, key, frequency and virtual needle display
- Backlight changes from red to green when in tune
- Vibrations picked up through clip transducer or internal mic
- Display rotates throughout 360 degrees and tilts to suit viewing angle



Description	Code	Price (Ex VAT)
Clip-on Tuner	476-210	£15.20

Violin Tuner

This is a slimline pocket size digital tuner for violins and guitars with internal speaker for sound demonstration.



Standard Clip-On Pickup

This is a standard clip-on pick-up with a lightweight flexible cable.



Violin Clip-On Pickup

This is designed to clip in the sound hole and it is able to pick up the original tone of your violin regardless of any background noise.



Metronome Black

This is a traditional mechanical metronome in a black plastic housing. Colour Black



Description	Code	Price (Ex VAT)
Violin Tuner	475-710	£12.30
Clip-on Pickup	475-730	£3.65
Violin Pickup	475-760	£6.20
Metronome	475-770	£24.50

Novation Ultranova

Analogue Synth with Effects

Nova series analogue-modelling synthesizer with a powerful effects processor.

- 18 voices, 14 filter types, 36 wavetables, 5 effect slots
- Patch Browse up to 300 sounds
- 2 in 4 out USB audio interface



NEW LOWER PRICE

Description	Code	Price (Ex VAT)
Ultranova	389-290	£332.50

Novation Mininova

Sound Module



MiniNova is a compact, super-cool performance synth with the same sound engine as its big brother: the UltraNova.

- 256 incredible onboard sounds with 5 knobs for tweaking
- 'Animate' sound with 8 back-lit buttons
- Brand new VocalTune and classic vocoder effects
- Comes with editing software and a software patch librarian
- 37 key controller keyboard with MIDI I/O

NEW LOWER PRICE

Description	Code	Price (Ex VAT)
Mininova	389-370	£224.17

Roland SP-404SX

Sampler

Roland's acclaimed SP-404 sampler takes an exciting leap forward with the SP-404SX.

- Enhanced sound quality with pure 16-bit linear sampling
- 29 DSP effects, including filter, delay, subsonic, and looper
- Versatile pattern sequencer with a new shuffle feature
- Smooth FX switching
- 3 control knobs, 12 trigger pads, and Sub Pad
- 1GB SD card is included



Description	Code	Price (Ex VAT)
SP-404SX	309-190	£299.17

INSTRUMENTS

Pianos + Synthesizers

Novation Bass Station II

Analogue Synthesizer

The Classic Novation BassStation Synth reworked for the 21st century.

Bass Station II is an analogue mono synth with a talent for bass, but a sound-engine that is versatile enough to kick out sharp leads and crisp arpeggios. It brings the best elements of the original BassStation into a brand new design with re-worked modulation, effects, filters and more; like the BassStation, but much, much bigger. The signal path is pure analogue - including the effects section. The hardware has been laid out in modules with dedicated pots, switches, sliders and buttons for all major parameters. Critically, you can store and recall patches on Bass Station II. It comes with 64 killer factory presets, space for 64 of your own sounds on the hardware, and you can store more on your computer. The key-mechanism consists of 25 full-sized keys that are velocity sensitive with assignable aftertouch. It has been developed as a 'synth-action' keyboard, where each key is individually sprung so it is light to the touch and highly responsive to the synth engine. Bass Station II is a fully class compliant MIDI device with MIDI I/O on 5 pin din ports - for connecting to other MIDI outboard - and your computer over USB.



NEW LOWER PRICE

Description	Code	Price (Ex VAT)
Bass Station II	389-420	£307.50

DELIVERY BEFORE NOON
no problem

Roland System 1

Plug Out Synthesizer

Innovative design with performance ready controls and quality construction.

- Four oscillators for buckets of fat synth tones
- Oscillator colours create continuous waveform changes
- Advanced Arpeggiator with SCATTER
- Variety of modulation functions
- -12dB and -24dB filter types with independent high pass filters
- Innovative thin keyboard with 25 normal sized keys



Roland TR-8

Rhythm Performer

Every control has a solid, predictable feel with each drum instrument having robust, "playable" faders.

- Illuminated knobs and RGB-lit buttons
- Control variations in your patterns and any incoming external signal
- Reverse, glitch, gate, truncate, stutter and perform rhythmic variations
- 10 different types of Scatter and adjust the intensity or 'Scatter Depth'
- Realtime pattern creation up to 32 steps



Alesis Vortex Keytar

MIDI Controller



The first keyboard guitar to include a MIDI-assignable accelerometer and eliminates the barrier between you and your audience.

- Best of NAMM 2012 Winner by Gear Guruz
- 37 velocity-sensitive keys with aftertouch for a compact melodic range
- Works with all of your software instruments and synths on MAC or PC
- FREE virtual synth from Sonivox.com
- Ableton live lite Alesis Edition software included

Description	Code	Price (Ex VAT)
System 1	319-130	£412.50

Description	Code	Price (Ex VAT)
TR-8	319-150	£332.50

Description	Code	Price (Ex VAT)
Vortex Keytar	385-840	£107.50

Roland VT-3

Voice Transformer

Easy voice transformation with vocoder, lo-fi effects, and synths you can sing.

- Tempo control knob and a Fine adjustment knob for total tempo control
- 16-step sequencer to switch between [A] and [B] and continuous playback
- Play drum instruments and record to steps in real-time
- Pattern creation up to 32 steps
- 8 Rec/Play modes
- Realtime play of 4 different types of rolls
- 7 segment, 4 character LED display



Roland TB-3

Touch Bassline Synthesizer

Packed with 134 sounds that live and breathe.

- 134 captivating sounds including 4 oscillator effects-processed tones
- Pressure sensitive Touch Pad
- Dedicated Tempo control with Shuffle and Tap Tempo
- Control built-in effects with smooth, responsive knobs
- 7 segment, 3 character LED display
- Seamless switch between pattern creation and performance
- 16-step indicator lights to aid in pattern creation
- Pattern support for up to 32 steps
- Easy access to Shuffle control



Description	Code	Price (Ex VAT)
VT-3	319-160	£132.50

Description	Code	Price (Ex VAT)
TB-3	319-140	£204.17

Roland RD64

64-Note Digital Piano



A compact, weighted-action 64-note stage piano with a SuperNATURAL Piano sound engine with authentic, expressive acoustic piano sounds.

- Vintage electric pianos modelled with accuracy
- Two-band EQ and reverb, plus two multi-effects
- Pitch bend/mod lever and D-BEAM
- iPad compatibility
- 12 versatile tones including clav and organ

Description	Code	Price (Ex VAT)
RD64	319-020	£457.50

Roland F-20CB

Digital Piano Black



Recording and metronome functions, onboard rhythm accompaniment, and a wide selection of other sounds including strings, organs and bass.

- Dual and Split modes for layering tones and playing different sounds with the left and right hands.
- SuperNATURAL Piano sound engine from flagship Roland pianos
- Built-in Rhythm intelligently follows your playing, plus a wide selection of additional sounds such as organs, strings, guitars, choir, and more
- Connect USB memory to save songs and play along with songs in WAV or SMF format
- Included DP-10 Damper Pedal

Description	Code	Price (Ex VAT)
F-20CB	319-030	£399.17

Korg Volca

Analogue Synthesizer

The Volca series share common elements: SYNC jack and MIDI IN, Self-tuning function (Volca Bass and Keys only), battery powered with internal speakers.

- **Volca Beats:** Peerless beats generated by solid analogue drum sounds and an Electribe-style sequencer
- **Volca Bass:** Powerful analogue bass sound creation and an Electribe-inspired sequencer for the ultimate bass lines
- **Volca Keys:** The ideal introductory synthesizer, with a simple – yet powerful – polyphonic analogue sound engine and loop sequencer



Description	Code	Price (Ex VAT)
Volca Beats	283-270	£99.17
Volca Bass	283-280	£99.17
Volca Keys	283-290	£99.17

Keyboard Accessories

M Audio SP-2

Sustain Pedal

High-quality damper pedal with expressive half-pedal capabilities.

- The perfect product for keyboard players who want the most realistic pedal action.
- Used in the same manner as the sustain pedal on an acoustic piano.
- Works with any M Audio keyboard.
- Designed to work and feel just like an acoustic piano's sustain pedal
- Specially designed rubber bottom that grips the floor and stays put while you play



Description	Code	Price (Ex VAT)
SP-2	363-730	£20.80

M Audio SP-1

Sustain Pedal

A simple, compact and sturdy sustain pedal for today's electronic keyboard.

- Equally useful for synthesizers, tone modules, and drum machines.
- The SP-1 is perfect for any application that requires a non-latching momentary switch.
- It is compatible with all electronic keyboards.



Description	Code	Price (Ex VAT)
SP-1	363-720	£14.50

Behringer FCV100

Foot Controller

Flexible dual-mode foot pedal for volume and modulation control.

- Features volume control of one stereo or two individual musical instruments
- Dedicated modulation function provides a direct connection to a keyboard's modulation control input
- VCA controlled for utmost reliability and smooth audio performance
- Not suitable for use with electric guitars



Description	Code	Price (Ex VAT)
FCV100	370-970	£23.33

FREE catalogue
 Are you reading someone else's catalogue? Why not call us and order your own copy...
it's free!

INSTRUMENTS

Keyboard Accessories

CONTINUED

Behringer KT108

Keyboard Amp

Ultra-compact 15-watt keyboard amplifier with VTC-Technology.

- Extremely versatile 2-channel keyboard amplifier
- Powerful 20-watt, 8" dual-cone Bugera speaker for wide frequency response
- 2 Instrument inputs with separate volume control for each channel
- VTC Virtual Tube Circuitry for tube-like sound & EQ
- CD input allows you to play along to your favourite music



Description	Code	Price (Ex VAT)
KT108	383-380	£55.00

Heavy Duty Footswitches

High quality footswitches, rated at 60V/5A.

- Pressed steel box with non-slip mat on the bottom and chromed switch on top
- Fitted with a 4.8m H/D lead and a 1/4inch (6.35mm) mono Jack
- Two varieties, with latching action or with momentary action
- 111 x 80 x 45mm



Description	Code	Price (Ex VAT)
Footswitch Latching Action	450-490	£12.50
Footswitch Momentary Action	450-500	£12.50

Yamaha FC4

Sustain Pedal

Quality sustain pedal suitable for Yamaha keyboards.

- May not be suitable for other keyboards.



Description	Code	Price (Ex VAT)
FC4	364-220	£29.70

Sustain Pedal

Sustain type pedal with switch.

- Suitable for all makes of keyboard



Description	Code	Price (Ex VAT)
Sustain Pedal	361-330	£9.90

Behringer AB200

Dual A/B Switch

An ideal accessory for stage and studio applications.

- Ultra-compact 2-channel footswitch
- Easily switch between two input signals into one output or vice versa
- Latching/non-latching modes are selectable for both channels



Description	Code	Price (Ex VAT)
AB200	380-340	£27.50

INSTRUMENTS

Drums

Korg Wavedrum

Mini Percussion Synth

Produces dynamic sounds by strokes of the hand.

- 2nd Generation Dynamic Percussion Synthesizer
- Innovative technology combines DSP synthesis and PCM playback
- 100 preset programs with live mode stores up to 12 programs
- 100 user programs & 100 loop phrases



Description	Code	Price (Ex VAT)
Wavedrum	283-210	£199.99

Roland TD11K

Drum Kit

An entry level kit that comes with the V-compact moniker.

- Comes with backing songs to play along with and a built-in USB function for easy file transfer
- Coach function to help users build up their drumming skills
- Pedal PDX-8 Mesh-Head snare (Roland's dual trigger technology)
- PD-8A Toms offer accurate triggering so you'll never miss a beat
- CY-5 cymbals with a 10" playing zone
- Kick drum pedal not included



Roland TD11KV

Drum Kit

A step-up from the TD-11K but offers an upgrade on its Toms and Cymbals.

- 6.5" PDX-6 Mesh Head Tom Pads
- CY-12C gives the crash natural swinging motion and choke control.
- CY-13R Ride Cymbal gives the user an enlarged bow area to play
- SuperNATURAL-enhanced sound engine with Behavior Modelling
- Diverse sound library
- Kick drum pedal not included



Description	Code	Price (Ex VAT)
TD11K	309-100	£690.83
TD11KV	309-820	£974.17

Roland TD4KP

Portable V-Drums Drum Kit

Bridges the gap between the compactness of the HD-3 and the advanced technology of the TD-4.

- Portable Collapsible Electronic Drum Kit
- Renowned V-Drums sound and quality in an ultra-portable mobile kit
- Includes TD-4 percussion sound module
- Eight pads total: kick, snare, toms x3, hi-hat, crash and ride cymbals
- FD-8 hi-hat controller included
- Kick drum pedal not included



Description	Code	Price (Ex VAT)
TD4KP	309-950	£474.17
TD4KP + Case	309-951	£520.83

Alesis DM7X

E-Drum Kit

The DM7X Kit serves up plenty of drums and cymbals, an intuitive module with hundreds of sounds, and ties it all together with a preassembled rack that will have you playing in minutes.

- Complete with 40 classic and modern ready-to-play kits
- Drum and cymbal buttons are arranged to resemble the layout of a traditional kit
- Stereo aux input allows you to jam along to your favorite tracks on your CD or MP3 player.
- Five advanced design 8" dual-zone drum pads—four toms plus the snare



Alesis DM6

5-Piece Drum Kit

The DM6 Kit from Alesis is a complete electronic drum set with every component needed to start playing drums.

- The included DM6 drum sound module features 108 high-quality percussion sounds.
- The pads and cymbals have a natural playing feel
- Versatile and well-equipped.



Alesis DM Lite

Electronic Drumset with Portable Folding Rack

NEW

Complete kit with pre-assembled rack has you playing in minutes.

- LED illuminated drum and cymbal pads
- DM Lite drum module with built-in drum coach
- 10 ready-to-play classic and modern kits - over 200 drum and cymbal sounds
- 1/8" stereo aux input
- USB/MIDI connection
- Includes drum sticks, all required cables, mounting hardware, and power supply



Description	Code	Price (Ex VAT)
DM7X	395-060	£407.50
DM6	385-780	£258.32
DM Lite	395-070	£165.83

Performance Percussion PP3005L

5-Piece Drum Kit

Improving their sound even more, Performance Percussion PP300 drum kits now come fitted with Remo® drum heads!

- High performance Remo® drum heads which have famously been used by Ringo with The Beatles to Chad Smith with The Red Hot Chili Peppers
- No. 1 choice as the best value, best equipped entry and educational level range available today



Description	Code	Price (Ex VAT)
PP3005L	601-340	£299.00

VISIT
our trade counter

You'll get friendly advice and immediate access to 8000+ product lines!

Chord ADK5

Drum Kit Black

5-piece kit comprising 22" Kick drum, 16" Floor tom, 13" and 12" toms and a 14" snare.

- 14" Hi-hats and a 16" crash cymbal are included
- Stands and pedal beater for the kick and a padded drum throne
- Sticks, drum key and hex key are also included
- All shell hardware is black metal including lugs which are plastic coated cast metal
- Shells are gloss vinyl covered



Drum Tech DTP4 Pack Of 4

Drum Set Practice Pads

Heavy duty 14" rubber practice pad.

- Fits onto a snare drum or any flat surface for practising stick work
- It has an extra thick 6" diameter central section



Description	Code	Price (Ex VAT)
DTP4	601-390	£22.50

Telescopic Drum Brushes

With Coated Rubber Handles

Telescopic Drum Brushes.

- Coated rubber handles.



Description	Code	Price (Ex VAT)
Drum Brushes	601-440	£14.40

Hi Hat Clutch Deluxe

Drum Accessories

A rock solid Hi Hat Clutch.



Description	Code	Price (Ex VAT)
Clutch Deluxe	602-130	£7.60

Drum Key

Drum Accessories

Chrome plated heavy duty drum key.

- Movable T-bar handle for easy use



Description	Code	Price (Ex VAT)
Drum Key	602-250	£1.94

Performance Percussion Drum Sticks

Box Of 12 Pairs



Popular sized wood and nylon tip drum sticks available in these three following styles:

Description	Code	Price (Ex VAT)
5A Wood Tip	601-410	£26.40
5B Wood Tip	601-420	£26.40
7A Nylon Tip	601-430	£26.40

Drum Bag Set

Drum Accessories

Keep your drum kit looking as good as possible whether you're on the move or storing it at home.

- Heavy duty over-stitched carry handles
- Anti-scratch interior material
- Very high density padding for protection
- All stowable into kick drum bag



Description	Code	Price (Ex VAT)
Pro 5-Piece	476-300	£139.50
Deluxe 5-Piece	602-620	£77.40

Performance Percussion Cajon

With Case

Lightweight compared to some more costly versions in the market.

- Traditional looking with a rear sound-hole and four small rubber feet
- Snare mechanism consists of four vertical (non-adjustable) guitar-string snares
- Finger tones and slaps complement the rich bass response nicely
- Comes with a padded carrying bag



Description	Code	Price (Ex VAT)
Cajon with case	602-290	£66.50

Drum Practice Pad

Hexagon

8 inch hexagonal drum pad with protective foam base for table-top stick practice.

- High density rubber surface
- Dimensions 210 x 25 x 240mm

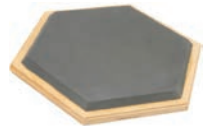

Description	Code	Price (Ex VAT)
Practice Pad Hexagon	602-770	£15.30

Drum Practice Knee Pad

4 inch drum practice pad with carved wooden base and strap for fastening to the players knee for stick practice on the move.

- Portable & convenient stick practice
- Dimensions 108 x 70 x 108mm



Description	Code	Price (Ex VAT)
Knee Pad	602-780	£11.50

Cymbal Felts Pack of 2

Drum Accessories

Pack of 2 spare cymbal felts.

- Available in 40mm or 50mm sizes.



Description	Code	Price (Ex VAT)
Cymbal Felts 40mm	602-090	£1.21
Cymbal Felts 50mm	602-100	£1.21

Bass Drum Felt Beater

Drum Accessories

Bass Drum Beater.

- Steel, chrome plated shaft with round felt beater



Bass Drum Plastic/Felt Beater

Drum Accessories

Bass Drum Beater.

- Double sided head, hard plastic/felt
- Steel, chrome plated shaft



Bass Drum Pedal Tension Spring

Drum Accessories

Bass Drum Pedal Tension Springs.

- Chrome plated heavy duty spring suitable for most types of bass drum pedal



Description	Code	Price (Ex VAT)
Felt Beater	602-170	£2.10
Plastic/Felt Beater	602-180	£3.80
Tension Spring	602-190	£2.50

Boss RC-505

Loopstation

Delivers a wide range of real-time processing options.

- Five stereo phrase tracks
- 99 phrase memories
- 85 onboard rhythm patterns
- External control via MIDI and optional footswitches or expression pedal
- XLR mic input with phantom power, mono/stereo instrument inputs, and stereo AUX in



Description	Code	Price (Ex VAT)
RC-505	319-010	£374.17

Roland DR-3 DR Rhythm

Drum Machine

Ultra-affordable drum machine includes some of Boss' best acoustic and electronic drum kits and a selection of bass sounds, while Rhythm Progressions and multiple variations make it easy to create a realistic-sounding drum track for any style of music.

- Velocity-sensitive pads
- 100 preset + 100 user styles



Description	Code	Price (Ex VAT)
DR-3	309-700	£120.83

INSTRUMENTS

Drum Accessories

Snare Head

Drum Accessories

Replacement 14" snare drum head from Performance Percussion.

- Available in clear bottom skin and white coated top skin



Description	Code	Price (Ex VAT)
14" White Coated	602-070	£9.13
14" Clear Bottom	602-080	£4.95

1000s
of products
Available from stock!

INSTRUMENTS

Drum Accessories

CONTINUED

Drum Stick Holder Deluxe

Conveniently clamps onto most stands or drum hardware.

- Clamps to most stands or hardware
- Pouch can be removed for cleaning and storage purposes
- Great for drum sticks, percussion mallets, wire brushes, rutes etc



Description	Code	Price (Ex VAT)
Drum Stick Holder Deluxe	603-080	£9.99

Bass Drum Head

22" Black

Replacement 22" plain black bass drum head.

- From Performance Percussion



Description	Code	Price (Ex VAT)
Bass Drum Head	602-000	£11.30

Drum Kit Silencer Pad Kit

This set of 7 pads sit on your drum kit offering silent practice while maintaining stick feel and bounce.

- Set includes 12" and 13" for toms, 14" for snare, 16" for floor tom, 22" for bass drum and 2 cymbal pads
- Foam (bass drum), Rubber (others)
- Weight 3.98kg



Description	Code	Price (Ex VAT)
Drum Kit Silencer Pad Kit	603-100	£37.50

INSTRUMENTS

Percussion

PK04 Latino Pack

Percussion Kit With Bag

Easy storage in the multi-compartment and pocketed nylon holdall keeps all the instruments tidy and together.

- Painted wood Maracas – pair
- Metal Shaker
- Painted wood Guiro/Stick
- 2 wood toneblocks/beaters – 6"
- Wood toneblock/beater – 9"
- Handle castanets – pair
- Headless Tambourine – 8"/25cm
- Tambourine with vellum head – 8"/25cm
- 5x Triangles/beaters – 3", 4", 5", 6", 8"
- Double Agogo
- 2 finger castanets



Description	Code	Price (Ex VAT)
PK04	601-470	£52.50

Performance Percussion Double Agogo

With Wood Beater

Supplied with wood beater/scrapper

- Made of wood



Description	Code	Price (Ex VAT)
Double Agogo	601-710	£7.38

Angel Glockenspiels

Bell Set

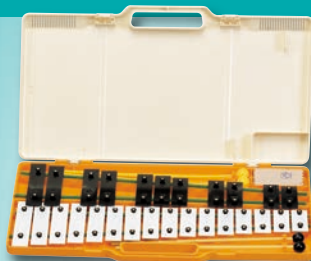

Ideal for teaching children about basic musical harmony...

Angel Glockenspiels have dedicated cases for portability and storage with many having adjustable feet, these Glockenspiels are great for primary school use. Each chime is made of gong quality steel and is electronically tuned to 5/100th of a semitone – consistent tuning across the range.

Description	Code	Price (Ex VAT)
Glockenspiels	601-620	£33.50

African Djembe 12"

Large With Cover

Larger dimensions of this Djembe give it increased depth of sound.

- Greater volume and a wider tonal vocabulary
- Includes an attractively patterned cover for the goatskin head



African Djembe 10"

Medium

Probably the best known of West African rhythm instruments.

- Extremely versatile and responsive hand drum with a wide range of tones
- Ideal for individual or ensemble playing



Description	Code	Price (Ex VAT)
Djembe 12"	601-490	£99.00
Djembe 10"	601-500	£54.00

Natural Wood Bongos

Percussion

Natural wood bongos with contrasting black hardware.

- 8"/20.5cm + 7"/18cm heads
- 4 lug head tension with drum key supplied
- Lacquer finish



Natural 2-Tone Wood Bongos

Percussion

Natural wood bongos with chrome hardware.

- 7.5"/19.05cm + 6.5"/16.51cm heads
- 4 lug head tension with drum key supplied
- Lacquer finish



Description	Code	Price (Ex VAT)
Wood Bongos	601-560	£26.00
2-Tone Wood Bongos	601-570	£26.00

Performance Percussion Wood Maracas

Multicolour

Painted bowl with pattern.

- Overall length 10.5"/27cm
- Colours and patterns may vary
- Sold as a pair



Performance Percussion Wood Maracas

Striped Pattern

Striped pattern maracas.

- Overall length 10.5"/27cm
- Sold as a pair



Performance Percussion Mini Maracas

Mixed coloured mini maracas.

- Plastic bowl
- Black plastic handles
- Overall length 5"/13cm
- Sold as a pair



Performance Percussion Egg Maracas

Handheld egg maracas.

- Mixed colours
- Sold as a pair



Description	Code	Price (Ex VAT)
Multicolour Maracas	601-670	£8.80
Striped Pattern Maracas	601-680	£8.20
Mini Maracas	601-690	£3.68
Egg Maracas	601-700	£3.68

Moon Tambourines

Sold Singly



Plastic 8.5"/21.5cm dia. 16 jingle pairs. Inset padded handle improves playability.

Description	Code	Price (Ex VAT)
Black	601-510	£9.50
Blue	601-520	£9.50
Red	601-530	£9.50
White	601-540	£9.50

INSTRUMENTS

Wind Instruments

Hornby 500H C

Descant Recorder



Manufactured from high quality plastics and ABS resin.

- Brown ABS 3pc construction body
- Air tight double sleeve joints ensures exact tuning throughout tonal range
- Cream coloured mouthpiece, ring joints and end piece
- Case, recorder grease, cleaning rod and notation chart included

Description	Code	Price (Ex VAT)
500H	601-930	£5.90

Odyssey OFL100 Debut C

Flute Outfit



Professional flute outfit, ideal for students and beginners...

Odyssey™ Debut Series flute offers many professional features; nickel plated 16 hole body and headjoint, undercut rolled tone holes, lip plate and embouchure hole designed for ease of blowing, silver plated keys, offset G key, stainless steel rods, springs and pins, adjustment screws and quality pads. Comes complete with cleaning cloth, cleaning tod/tuning guide, tuning stop grease, instruction guide and lightweight, strong, durable, plush lined, snug-fit interior ABS case.

Description	Code	Price (Ex VAT)
OFL100 Debut C	601-890	£93.33
Flute Care Kit	602-570	£13.00



Odyssey OTR140 Debut Bb

Trumpet Outfit



Trumpet with brass body, 11.68mm and 123mm bell.

- Stainless steel pistons, responsive top spring valve action, 1st valve slide saddle, 3rd valve slide ring, four tuning slides
- Plated 7C mouthpiece and clear lacquer finish.
- Complete with a large cleaning cloth, valve oil, instruction guide and a lightweight, strong, durable, plush lined, snug-fit interior ABS case

Description	Code	Price (Ex VAT)
OTR140 Debut	601-920	£97.50
Trumpet Care Kit	602-610	£14.77
Mouthpiece - Silver Plated	602-520	£13.00

Odyssey OCL120 Debut Bb

Clarinet Outfit



The OCL120 features 17 nickel plated keys with ABS body in wood finish.

- Stainless steel rods, springs and pins
- Undercut tone holes with quality pads and mouthpiece
- Two barrel joints
- Comes with large pull-through cleaning cloth, cork grease, double reed guard and reed
- Lightweight, strong, durable, plush lined, snug-fit interior ABS case

Description	Code	Price (Ex VAT)
OCL120 Debut	601-900	£110.87
Clarinet Care Kit	602-580	£13.90
Mouthpiece - Silver Plated	602-540	£21.73

Odyssey OAS130 Alto

Saxophone Outfit

Durable, attractive polished gold saxophone with clear lacquer brass body, engraved bell.

- Power forged keywork, stainless steel rods, springs and pins
- Pearloid keycaps
- High F# key
- Double braced pad cup on low C
- Quality pads and mouthpiece, adjustable thumb rest
- Lightweight, strong, durable, plush lined, snug-fit interior ABS case
- For full accessories, please see our website.



Description	Code	Price (Ex VAT)
OAS130 Debut	601-910	£259.00
Alto Saxophone Care Kit	602-590	£13.90
Alto Silver Plated Mouthpiece	602-550	£21.73
Tenor Saxophone Care Kit	602-600	£15.64
Tenor Silver Plated Mouthpiece	602-560	£24.34

Antoni Debut AVP44

Violin

Provides a tonality, and playing feel redolent of more expensive instruments...

- One-piece hand carved solid flame maple back
- Solid flame maple ribs
- Double inlaid purfling; Hand carved, close grain spruce table
- Hand carved satin finish maple neck
- Lightweight alloy tailpiece
- Ebony fingerboard and nut
- Ebony 'heart-style' tuning pegs with black pin and collar
- Ebony Guarneri pattern chinrest
- Octagonal Brazilwood bow with white tip
- Nickel silver winding and leather lapped
- Decorative mounted ebony frog with nickel silver ferrule, decorative eye and inlaid screw
- Oblong 'nil-gravity' hard foam case



Description	Code	Price (Ex VAT)
AVP44	601-830	£133.30

Antoni Debut ACC35

Full Size Cello

Two-piece figured hand carved solid maple back cello.

- Solid maple ribs
- Hand carved solid spruce belly
- Satin finish maple neck with gloss finish scroll, high gloss antique brown varnish
- Ebonised hardwood fingerboard, nut, endpin and turning pegs
- Lightweight alloy tailpiece
- Round Brazilwood bow with natural white horse hair
- Decorative mounted ebonised hardwood frog with nickel silver ferrule and screw
- Heavy, deep padded water resistant 600 denier nylon cordura bag with external bow pockets



For more features for this product, please see our website.

Description	Code	Price (Ex VAT)
ACC35	601-870	£329.57

Antoni Debut ACV30

Full Size Violin

Two-piece figured hand carved solid maple back violin.

- Solid maple ribs
- Solid spruce hand carved table
- Satin finish maple neck with gloss finish scroll, high gloss antique brown varnish
- Ebonised hardwood fingerboard, nut, endpin, turning pegs and chinrest
- Lightweight alloy tailpiece
- Round Brazilwood bow with natural white horse hair
- Decorative mounted ebonised hardwood frog with nickel silver ferrule and screw
- Shaped 'nil-gravity' hard foam case
- Emerald green plush lined fitted interior
- Rosin



Description	Code	Price (Ex VAT)
ACV30	601-840	£56.51

Stentor Student I

Violin And Viola Outfit

Ideal entry level instrument suitable for intermediate Grades.

- Hand carved from solid tonewoods
- Good quality rosewood pegs
- Black finished KunTian fingerboard
- Alloy tailpiece with four integral adjusters
- Reliable student wood bow
- Well designed lightweight case with accessory pockets and carry straps



Description	Code	Price (Ex VAT)
Violin 4/4	605-000	£66.50
Violin 3/4	605-010	£59.90
Viola 15"	605-020	£94.50
Viola 12"	605-030	£107.50

1000s of products Available from stock!

MORE PRODUCTS online

FOR fax orders Use our fax number... 020 8450 4390

INDEX

CABLE

Cables + Connectors		
Cable	Guitar	216
	1 Core	217
	2 Core	218
	Miniature 2 Core	220
	Bantam + Studio Wiring	220
	Multicore	220
	AES-EBU	222
	Video	222
	Speaker	222
	Mains	224
Cable Identification		
Cable Insulation		
Cable Harnessing		
RFI Suppression		
Cable Glands		
Cable Testers		
Cable Drums		
Stage Boxes		
Floor Boxes		
Wall Boxes		
Connectors Multiway		
	XLR	231
	XLR Accessories	233
	Bantam/TT	233
	Tiny QG XLR	234
	Jack	234
	Mini Jack	236
	BNC	236
	MIDI/DIN	237
	Phono	237
	Speaker	237
	Ethernet	238
	Feed Through Chassis	239
Adaptors		
Signal Splitters		
Audio Adaptors		
Optical Adaptors		
Mains Components		
Mains Filters		
Distribution/Conditioners		
Power Sequencers		
Guitar Pedal Power Supplies		
Low Voltage Supplies		

Guitar Cable

Klotz AC110

Guitar Cable



The AC110 has the lowest capacitance of any cable we can find, at 70pF/m.

The high and medium impedance of the average guitar pickup requires a connecting cable which is of very low capacity and has good screening properties. Otherwise the high frequencies will be attenuated with sound losing much of its sparkle and the cable will be susceptible to hums, buzzes and taxis! Klotz AC110 cable has enhanced dual screening, the inner screen is a plastic conductive screen to discharge static which causes crackles when handled. The main screen is a spirally wound copper screen, the design of which allows good flexibility. Colour Black.

Capacitance pF/m between conductors	Capacitance pF/m conductor to earth	DC Resistance of conductor Ω/m	No of strands and their diameters	Cross sectional area sq mm	Screening method	Overall dia mm
n/a	70	0.085	7 x 0.2mm	0.22	copper spiral + plastic	6.9

Description	Code	Price (Ex VAT)					
AC110	544-590	1+	£1.44	50+	£1.29	200+	£1.16
AC110 Drum 100m	544-591	1+	£119.00	2+	£113.00	5+	£109.00

Europa ZX

Coloured Guitar Cable

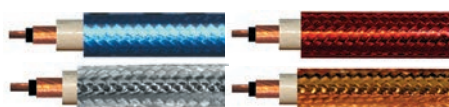

The ultimate specifications and an appearance that makes you want to touch the outer jacket.

- The screening uses 64 strands of 0.12mm dia copper
- Spirally wound to maintain flexibility
- Inner conductor is surrounded by a special type of dielectric PVC, which in itself is surrounded by a carbonised PVC tube to discharge static.
- Sheathed within a tough richly coloured 7mm PVC jacket
- Sold by the metre

Description	Code	Price (Ex VAT)				
Black	548-140	1+	£0.79	50+	£0.69	
Blue	548-150	1+	£0.79	50+	£0.69	
Red	548-160	1+	£0.79	50+	£0.69	
Silver	548-170	1+	£0.79	50+	£0.69	
Gold	548-180	1+	£0.79	50+	£0.69	

Europa Guitar Cable



A premium Grade guitar cable which requires special considerations due to the high impedance of the guitar pickup.

- The screening uses 64 strands of 0.12mm dia copper
- Spirally wound and maintains flexibility and provides an excellent screening capability
- Dielectric PVC material surrounding the inner conductor.
- Drum length 100 metres
- Overall diameter 7.3mm
- Sold by the metre

Capacitance pF/m between conductors	Capacitance pF/m conductor to earth	DC Resistance of conductor Ω/m
n/a	117	0.08
No of strands and their diameters	Cross sectional area sq mm	Screening method
20 x 0.12	0.22	Lapped Copper

Description	Code	Price (Ex VAT)			
Guitar Cable Black	548-110	1+	£0.49	50+	£0.44

Sommer Spirit

SOMMER CABLE

Guitar Cable



This Sommer Guitar cable has one of the best specifications we can find.

The cable's chunky jacket will protect the contents from all but the worst abuse. Because guitar pick ups demand high impedance circuits, any internal cable capacity will seriously attenuate high frequencies. By increasing the distance between the inner conductor and the shield, Spirit cable benefits from very low self capacity (70pF/metre) This critical figure is further enhanced by employing an advanced foamed dielectric insulator. This in turn is encased in a semiconducting graphite plastic tube which discharges and antistatic is generated when the cable is flexed. Again, high impedance circuits would suffer without this antistatic tube. Dense spirally wound copper strands form a 100% shield against interference and help maintain a supple cable. Still supple down to -30oC. Colour Black.

Capacitance pF/m between conductors	Capacitance pF/m conductor to earth	DC Resistance of conductor Ω/m	No of strands and their diameters	Cross sectional area sq mm	Screening method	Overall dia mm
n/a	78	0.038	28 x 0.15mm	0.5	lapped copper	7.0

Description	Code	Price (Ex VAT)					
Spirit Black	546-150	1+	£1.98	50+	£1.78	100+	£1.51
Spirit Black XXL	546-155	1+	£2.49	50+	£2.28	100+	£1.99

WHICH cable do i need?

GUITAR CABLE/INSTRUMENT CABLE

Europa Guitar cable, Europa ZX Coloured Guitar cable, Klotz Guitar cable or Sommer Spirit cable. All are strong, very flexible and have good screening and antistatic properties. If interference may be a problem (eg. on stage) use Europa Double Screened Unbalanced cable.

If you need more information, please contact our technical sales team, who will be glad to help further.

Europa Premium Plus Guitar Cable

Black Cloth Guitar Cable



A very high quality flexible Black cloth covered Guitar cable which included everything plus a wow factor!

- Polypropylene silk under the jacket maintain the long term shape. The spirally wound Oxygen Free copper shield rejects hums and taxis!!
- A graphite polypropylene tube stops static when flexed.
- Low loss insulator material keeps the internal capacity to a minimum
- Inner conductor is multistranded Oxygen Free copper wire.

Description	Code	Price (Ex VAT)			
Premium Plus	548-190	1+	£0.82	10+	£0.72

Single Core Cable

Klotz Installation Cable



Klotz Installation Cable is a high performance cable with low losses.

- At 110pF per metre this cable is amongst the lowest available
- Dual screening is employed
- Antistatic conductive plastic shield surrounds the conductor which in turn is covered in a lapped copper screen
- Overall diameter 4mm so many cables can be included in a tight space
- Colour Black

Capacitance pF/m between conductors	Capacitance pF/m conductor to earth	DC Resistance of conductor Ω/m
n/a	110	0.09
No of strands and their diameters	Cross sectional area sq mm	Screening method
7 x 0.2mm	0.22	Copper + Plastic

Description	Code	Price (Ex VAT)			
Installation Cable	544-100	1+	£1.39	100+	£1.23

Europa Double Screened

Unbalanced Cable



Solves the issue of problematic unbalanced circuits being prone to interference. Has never been known to fail.

- Signal wire is surrounded by a conductive plastic PVC tube and TWO braided copper screens
- Ideal where there is interference from unknown sources
- Generous amounts of copper are used throughout. Diameter 8mm

Description	Code	Price (Ex VAT)			
Double Screened	548-130	1+	£0.69	50+	£0.62

Sommer Cable Onyx 2025 MKII



Similar in construction and quality to the Tricone, but a little thinner due to the twin construction.

- Suitable for the fabrication of HiFi-cables, adaptors, and for fixed installation
- Fits almost all Jack and cinch plugs
- The ONYX can be separated at the centre of the cable
- Each wire has its own copper spiral shielding and is equipped with a thick jacket
- Plus, the insulation is White and Red and easy to distinguish
- Overall diameter 3.8 x 6 mm

Capacitance pF/m between conductors	Capacitance pF/m conductor to earth	DC Resistance of conductor Ω/m
n/a	58	0.117
No of strands and their diameters	Cross sectional area sq mm	Screening method
32 x 0.1mm	0.25	Copper Spiral

Description	Code	Price (Ex VAT)			
Onyx 2025	546-160	1+	£1.49	50+	£1.34

Sommer Tricone II

SOMMER CABLE

Instrument Cable



Where unbalanced single conductor cable is to be used in unpredictable situations then this Tricone cable is a major contender.

The outer diameter is 5.9 mm because the inner conductor houses a very low loss foamed dielectric to minimise high frequency loss in high impedance circuits. The dielectric is then surrounded by a carbonised plastic antistatic tube which stops crackles when the cable is moved. Again, high impedance circuits would suffer without this antistatic tube. Dense spirally wound copper strands form a 100% shield against interference and helps maintain a supple cable. Still supple down to -30C. Four colours.

Capacitance pF/m between conductors	Capacitance pF/m conductor to earth	DC Resistance of conductor Ω/m	No of strands and their diameters	Cross sectional area sq mm	Screening method	Overall dia mm
n/a	85	0.09	28 x 0.1	0.22	Copper + carbon	5.9

Description	Code	Price (Ex VAT)					
Black	547-160	1+	£0.82	50+	£0.78	100+	£0.74
Red	547-180	1+	£0.82	50+	£0.78	100+	£0.74
Blue	547-170	1+	£0.82	50+	£0.78	100+	£0.74
Green	546-830	1+	£0.82	50+	£0.78	100+	£0.74

Sommer Tricone XXL

SOMMER CABLE

Instrument Cable



Tricone XXL focuses on performance which becomes apparent on longer cable runs.

The inner conductor is 0.5mm² which lowers DC resistance signal losses whilst the new dielectric provides a very low self capacitance. The screening is lapped copper with a carbonised tube surrounding the inner conductor to stop static being generated when the cable is flexed. The compound jacket gives the Tricone XXL a high tread resistance and tensile strength.

Capacitance pF/m between conductors	Capacitance pF/m conductor to earth	DC Resistance of conductor Ω/m	No of strands and their diameters	Cross sectional area sq mm	Screening method	Overall dia mm
n/a	85	0.2	28 x 0.15	0.5	Lapped Copper + carbon	5.9

Description	Code	Price (Ex VAT)					
Black	547-210	1+	£1.35	50+	£1.17	100+	£0.99
Red	547-230	1+	£1.35	50+	£1.17	100+	£0.99
Blue	547-220	1+	£1.35	50+	£1.17	100+	£0.99

Europa Unbalanced Cable

Instrument Cable



A premium grade cable for installation and equipment interconnection.

The conductors use generous amounts of copper to keep signal losses to zero. The screening uses 64 strands of 0.12mm dia. copper. It is spirally wound which maintains flexibility and provides excellent screening. The material surrounding the inner conductor is of a special type of dielectric PVC which minimises capacity losses which maintains the high frequencies. Surrounding this dielectric PVC is a carbonised PVC tube. This effectively conducts away any static that would be generated should the cable be flexed. This is then sheathed within a 6mm PVC jacket. Drum length 100 metres. Manufactured to the ISO9001 standard.

Description	Code	Price (Ex VAT)					
Black	548-000	1+	£0.41	50+	£0.36	100+	£0.32
Black Drum 100m	548-001	1+	30.79	2+	29.67	5+	28.58
Red	548-010	1+	£0.41	50+	£0.36	200+	£0.32
Blue	548-020	1+	£0.41	50+	£0.36	200+	£0.32
Green	548-030	1+	£0.41	50+	£0.36	200+	£0.32
Compact Version. 5mm jacket diameter. Black.	548-100	1+	£0.33	50+	£0.29	200+	£0.26

CABLE

2 Core Balanced Cable

Europa Premium

Microphone Cable

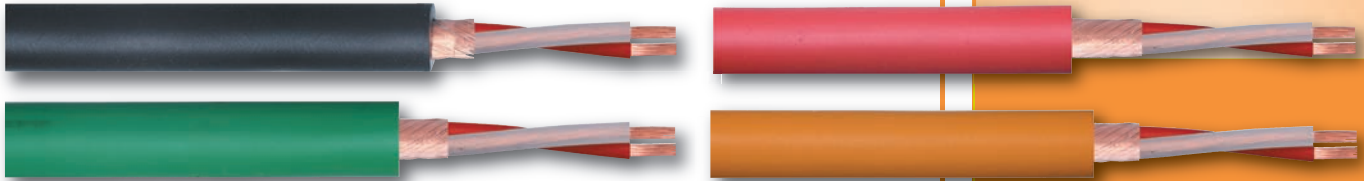

Flexibility is assured with a lapped copper screen with 64 strands of 0.12mm diameter copper wire. Signal losses are minimised by utilising low loss conductors with 20 strands of 0.12mm diameter copper wire.

Capacitance pF/m between conductors	Capacitance pF/m conductor to earth	DC Resistance of conductor Ω/m	No of strands and their diameters	Cross sectional area sq mm	Screening method	Overall dia mm
60	108	0.08	20 x 0.12mm	0.23	lapped copper	6.3

Description	Code	Price (Ex VAT)					
Black	548-200	1+	£0.45	100+	£0.39	300+	£0.33
Red	548-210	1+	£0.45	100+	£0.39	300+	£0.33
Blue	548-220	1+	£0.45	100+	£0.39	300+	£0.33
Green	548-230	1+	£0.45	100+	£0.39	300+	£0.33
Yellow	548-240	1+	£0.45	100+	£0.39	300+	£0.33
Violet	548-250	1+	£0.45	100+	£0.39	300+	£0.33
Orange	548-260	1+	£0.45	100+	£0.39	300+	£0.33
White	548-270	1+	£0.45	100+	£0.39	300+	£0.33
Black Cable Drum 100m	548-201	1+	£35.00	2+	£33.00	3+	£31.00
Red Cable Drum 100m	548-211	1+	£35.00	2+	£33.00	3+	£31.00
Blue Cable Drum 100m	548-221	1+	£35.00	2+	£33.00	3+	£31.00
Green Cable Drum 100m	548-231	1+	£35.00	2+	£33.00	3+	£31.00
Yellow Cable Drum 100m	548-241	1+	£35.00	2+	£33.00	3+	£31.00
Violet Cable Drum 100m	548-251	1+	£35.00	2+	£33.00	3+	£31.00
Orange Cable Drum 100m	548-261	1+	£35.00	2+	£33.00	3+	£31.00
White Cable Drum 100m	548-271	1+	£35.00	2+	£33.00	3+	£31.00

A premium grade microphone cable with a spec equal to cables costing treble.

The circular shape and stable impedance of the cable is enhanced by the use of strands of cotton filler. It is sheathed in a strong 6mm PVC jacket which remains flexible to -20 degrees. Manufactured to the ISO9001 standard.



Black Cable Drum 100m

Sommer Club Series II

Microphone Cable



Primarily designed as a stage microphone cable where mechanical durability is a major issue, even down to -30 degrees! Braided copper shielding guards against unwanted taxi breakthrough and thyristor lighting buzzes.

- Anti Kink construction by careful use of fillers pack cables tightly
- Oxygen Free copper and PE insulation throughout
- 95% screening coverage, normally around 85%
- Very tough outer jacket still flexible at -30 degrees! 6.5mm dia.

Capacitance pF/m between conductors	Capacitance pF/m conductor to earth	DC Resistance of conductor Ω/m			
58	115	0.055			
No of strands and their diameters	Cross sectional area sq mm	Screening method			
19 x 0.15mm	0.34	Braided copper			
Description	Code	Price (Ex VAT)			
Black	546-630	1+	£0.94	100+	£0.85
Blue	546-670	1+	£0.94	100+	£0.85
Red	546-640	1+	£0.94	100+	£0.85
Black Drum 100m	546-631	1+	£83.00	2+	£78.80

Sommer Source MKII Highflex

Microphone Cable



Originally designed for the manufacturers of professional studio microphones like Schoeps.

- Conductors surrounded by a conductive aluminium fleece again surrounded by a braided copper shield. The ultimate antidote for areas of high interference
- Centre conductors and shield have more than average amounts of copper to keep losses down to negligible proportions.
- Shielding is actually 100%, even with frequent bending and low temperatures. Overall dia 6.5mm.

Capacitance pF/m between conductors	Capacitance pF/m conductor to earth	DC Resistance of conductor Ω/m			
60	115	0.08			
No of strands and their diameters	Cross sectional area sq mm	Screening method			
32 x 0.1mm	0.25	Lapped + foil			
Description	Code	Price (Ex VAT)			
Black	546-000	1+	£1.68	100+	£1.45
Blue	546-010	1+	£1.68	100+	£1.45
Red	546-020	1+	£1.68	100+	£1.45

Sommer Symbiotic

Microphone Cable



Constructed for broadcast applications according to BBC and German radio specifications.

- Extremely flexible with a minute strand construction of 102 strands of 0.05mm copper wires
- Screening is of extremely tight counter rotating double spiral shielding
- Oxygen free copper conductors while the shielding factor is 100%
- Flexibility maintained down to -30oC. Overall dia 5.2mm.

Capacitance pF/m between conductors	Capacitance pF/m conductor to earth	DC Resistance of conductor Ω/m			
95	130	0.094			
No of strands and their diameters	Cross sectional area sq mm	Screening method			
102x0.05mm	0.2	Double lapped			
Description	Code	Price (Ex VAT)			
Black	546-780	1+	£2.25	100+	£1.72

DELIVERY BEFORE NOON no problem

Klotz MC5000

Microphone + Line Cable



Stands out by having great rejection of stray magnetic fields because it includes two counter wound copper screens.

- Maintains the flexibility and acts as a good insurance against hums, taxi breakthrough and lighting circuit buzzes.
- The two conductors are surrounded by a plastic compound which reduces the chance of kinking and replaces the more usual cotton filler
- A real problem solver which remains flexible
- Sold by the metre and 100m drum; Overall dia 7mm

Capacitance pF/m between conductors	Capacitance pF/m conductor to earth	DC Resistance of conductor Ω/m
75	125	0.04
No of strands and their diameters	Cross sectional area sq mm	Screening method
28 x 0.15mm	0.5	2x Lapped
Description	Code	Price (Ex VAT)
MC5000	544-600	1+ £2.62 100+ £1.97

Klotz Starquad



Large amounts of copper wire are used in a heavy braiding encasing 4 twisted signal conductors to balance out capacitive effects.

- The signal conductors include generous amounts of copper to minimise long length losses
- Frequently used for outside broadcasts, mobiles and near lighting rigs where conditions are unpredictable
- To promote ease of soldering, a drain wire runs inside the screening
- Overall dia 6.5mm

Capacitance pF/m between conductors	Capacitance pF/m conductor to earth	DC Resistance of conductor Ω/m
90	180	0.85
No of strands and their diameters	Cross sectional area sq mm	Screening method
28 x 0.10mm	0.22	Dense copper braid
Description	Code	Price (Ex VAT)
Quadflex	540-541	1+ £2.89 100+ £2.69

Klotz Microphone Cable

2 Core Balanced Cable



This cable is regarded as a standard by which all others are judged.

The jacket is of a rubbery like PVC which ensures flexibility in extremes of temperature. Additional cotton filler is included to reduce microphony by restricting sideways movement of the conductors relative to each other. Screening is a copper spiral sheath which helps to maintain the flexibility this version is noted for. Available in five colours.

Capacitance pF/m between conductors	Capacitance pF/m conductor to earth	DC Resistance of conductor Ω/m	No of strands and their diameters	Cross sectional area sq mm	Screening method	Overall dia mm
95	165	0.09	28 x 0.1mm	0.22	Copper Spiral	6.35

Description	Code	Price (Ex VAT)
Black	544-001	1+ £1.44 50+ £1.29 200+ £1.16
Red	544-021	1+ £1.44 50+ £1.29 200+ £1.16
Yellow	544-041	1+ £1.44 50+ £1.29 200+ £1.16
Green	544-051	1+ £1.44 50+ £1.29 200+ £1.16
Blue	544-061	1+ £1.44 50+ £1.29 200+ £1.16

WHICH cable do i need?

MICROPHONE LEADS

Europa Premium cable, Sommer Club, Sommer Source cable, Sommer Symbiotic cable or Klotz Microphone cable. In known hostile environments where RFI/Thyristor lighting is around, use Starquad. For Stereo Mic or Line applications use Europa Stereo Microphone cable. Two totally isolated balanced cables.

If you need more information, please contact our technical sales team, who will be glad to help further.

DELIVERY BEFORE 10AM no problem

Europa Stereo

Microphone Cable



A premium grade cable for situations where stereo mic or line cables are required.

- Two conductors each with 64 strands of 0.12mm and a spirally lapped screen of 20 strands of 0.12mm
- Overall dimensions are 10mm x 5mm
- Flexible Black PVC jacket
- Drum length 100 metres
- Covers any situation. Excellent screening and low losses

Capacitance pF/m between conductors	Capacitance pF/m conductor to earth	DC Resistance of conductor Ω/m
95	165	0.09
No of strands and their diameters	Cross sectional area sq mm	Screening method
28 x 0.1mm	0.22	Copper Spiral

Description	Code	Price (Ex VAT)
Stereo	548-120	1+ £0.79 100+ £0.61
Stereo Drum 100m	548-121	1+ £59.90 2+ £57.90

Europa Ultimate

Microphone Cable



Combines an exceptional performance with good mechanical characteristics.

- Cotton liner and cotton fillers maintains cable shape when abused
- Additional carbon screen stops crackling when moved.
- Braided copper screen and plastic screen stops interference
- New dielectric insulator increases HF performance

Capacitance pF/m between conductors	Capacitance pF/m conductor to earth	DC Resistance of conductor Ω/m
70	120	0.08
No of strands and their diameters	Cross sectional area sq mm	Screening method
20x 0.12	0.22	Braid+Carbon Plastic

Description	Code	Price (Ex VAT)
Black	548-900	1+ £0.65 100+ £0.57
Black Drum 100m	548-901	1+ £55.90 2+ £52.40
Red	548-910	1+ £0.65 100+ £0.57
Blue	548-920	1+ £0.65 100+ £0.57
Green	548-930	1+ £0.65 100+ £0.57
Yellow	548-940	1+ £0.65 100+ £0.57
Violet	548-950	1+ £0.65 100+ £0.57
Orange	548-960	1+ £0.65 100+ £0.57
White	548-970	1+ £0.65 100+ £0.57

Sommer SC Stage 22 Hiflex

SOMMER CABLE

2 Core Balanced Cable



The Stage 22 series is for dedicated stage use.

Specifically formulated to provide live systems with a cable of robust construction and great flexibility whilst retaining the performance associated with Sommer Cable. Live performances at multiple venues inevitably reveal problems with interference from either thyristor controlled lighting circuits, local mini cabs or even mobile phones. Supplied by the metre or 100m drum. 6 colours. Effective screening against these problems are provided by a spirally wound copper screen using 0.1mm individual strands. A quality braided screen provides 95% shielding, the SC Stage 22 Hiflex provides 99% screening! Flexibility is maintained right down to -20 degrees C so the cable will still remain flexible following a cold night stored in the back of a van.

Capacitance pF/m between conductors	Capacitance pF/m conductor to earth	DC Resistance of conductor Ω/m	No of strands and their diameters	Cross sectional area sq mm	Screening method	Overall dia mm
68	130	0.087	28 x 0.1mm	0.22	Spiral	6.4

Description	Code	Price (Ex VAT)
Black	546-710	1+ £0.79 100+ £0.71 300+ £0.63
Black Drum 100m	546-711	1+ £69.00 2+ £64.50 5+ £61.50
Red	546-720	1+ £0.79 100+ £0.71 300+ £0.63
Yellow	546-650	1+ £0.79 100+ £0.71 300+ £0.63
Green	546-660	1+ £0.79 100+ £0.71 300+ £0.63
Blue	546-730	1+ £0.79 100+ £0.71 300+ £0.63
Violet	546-680	1+ £0.79 100+ £0.71 300+ £0.63

CABLE

Miniature Cable

Sommer Scuba

Miniature Mic/Line Cable

scuba • 2x0,14mm (AWG26) • patch • OFC • by SOMMER CABLE Germany

The new SCUBA is well suited for connectors with a small diameter, for example LEMO patchboards, mini-jacks, cinch, and rack cabling.

Capacitance pF/m between conductors	Capacitance pF/m conductor to earth	DC Resistance of conductor Ω /m	No of strands and their diameters	Cross sectional area sq mm	Screening method	Overall dia mm
64	130	0.135	18 x 0.1mm	0.14	Copper braid	3.8

Description	Code	Price (Ex VAT)					
Black	540-401	1+	£1.07	100+	£0.96	300+	£0.82
Red	546-970	1+	£1.07	100+	£0.96	300+	£0.82
Green	546-980	1+	£1.07	100+	£0.96	300+	£0.82
Yellow	546-990	1+	£1.07	100+	£0.96	300+	£0.82
Grey	547-000	1+	£1.07	100+	£0.96	300+	£0.82

SOMMER CABLE

The SCUBA cable is very thin, saves space and is flexible.

The diameter and wire construction has been configured according to common broadcasting norms and dense copper braiding with 90% shielding protects the cable from interference. It is available in five different jacket colours. Black, Red, Green, Yellow and Grey.

Sommer Isopod SO-F22/SO-F50

Installation Cable



Frequently remembered for its "memory effect" Isopod cable can easily be installed round corners.

- The two conductors' shielding is by an aluminium/Pt foil which automatically adheres to the jacket when stripping
- Plastic jacket is extremely durable and was specially developed for this application
- Oxygen free copper conductors with shield connection via drain wire
- 200 metre drum; Overall dia 4.2mm
- SO-F50 same as above but with a larger wire diameter (2x0.50mm²) making it more suitable for crimping contacts.

Capacitance pF/m between conductors	Capacitance pF/m conductor to earth	DC Resistance of conductor Ω /m			
74	143	0.08			
No of strands and their diameters	Cross sectional area sq mm	Screening method			
28 x 0.15mm	0.5	Foil			
Description	Code	Price (Ex VAT)			
SO-F22	546-700	1+	£0.78	50+	£0.70
SO-F50	546-800	1+	£0.99	50+	£0.89

Sommer Cicada SO-D14



This tiny cable (2.6mm diameter) finds many applications where miniaturisation is an issue.

- Used for lavalier mics, headphones, headsets, goosenecks and installation purposes
- Cicada is very flexible and achieves a 95% shielding with dense spirally wound copper strands
- Oxygen free copper conductors
- Overall dia 2.6mm

Capacitance pF/m between conductors	Capacitance pF/m conductor to earth	DC Resistance of conductor Ω /m			
65	120	0.148			
No of strands and their diameters	Cross sectional area sq mm	Screening method			
18 x 0.1mm	0.14	Foil			
Description	Code	Price (Ex VAT)			
Cicada SO-D14	546-810	1+	£0.66	50+	£0.60

Bantam + Compact Studio Wiring

Klotz Patch Cable

Bantam/TT



Particularly suited for Bantam Patch cords where the PVC jacket screws into the bantam plug's handle.

- The copper braided screening increases the strain relief and makes for a more robust lead
- Used as a quality compact mic cable for static installations
- Overall diameter 4.6mm

Capacitance pF/m between conductors	Capacitance pF/m conductor to earth	DC Resistance of conductor Ω /m			
100	170	0.1			
No of strands and their diameters	Cross sectional area sq mm	Screening method			
24 x 0.1mm	0.19	Braid			
Description	Code	Price (Ex VAT)			
Patch Cable	544-580	1+	£1.75	50+	£1.55

Sommer Goblin

Bantam Patch And Microphone Cable



Similar electrical specification to the Source cable but with a reduced jacket thickness.

- Results in a very high performance but with a 4.6mm diameter
- Cable diameter suitable for TT/Bantam and B-gauge plugs
- Frequently used for rack wiring and interconnection purposes

Capacitance pF/m between conductors	Capacitance pF/m conductor to earth	DC Resistance of conductor Ω /m			
65	120	0.148			
No of strands and their diameters	Cross sectional area sq mm	Screening method			
18 x 0.1mm	0.14	Lapped + metal fleece			
Description	Code	Price (Ex VAT)			
Black	546-040	1+	£1.23	100+	£1.11
Red	546-060	1+	£1.23	100+	£1.11
Blue	546-050	1+	£1.23	100+	£1.11
Ice Grey	546-070	1+	£1.23	100+	£1.11

Multicore Cable

Sommer Quantum

AES/EBU Multicore



The QUANTUM can be wound in the shape of an "8" without twisting when wound or unwound.

- 5-PVC-jacket is resistant to a temperature of -30°C and still feels soft
- Break-resistant due to the super fine 0.07 mm individual copper litz and the PE-insulated wire insulation
- Each wire pair is insulated with a sleeve, numbered, and shielded with a copper spiral covered to 99%
- Features a low capacity of 45 pF wire/wire and remains 110 Ohm (AES/EBU) and conforms for hundreds of meters
- The inside is protected against adverse influences by a highly flexible PVC-jacket with a wall thickness of almost 2mm

Capacitance pF/m between conductors	Capacitance pF/m conductor to earth	DC Resistance of conductor Ω /m			
60	120	0.09			
No of strands and their diameters	Cross sectional area sq mm	Screening method			
24 x 0.1mm	0.18	Foil/Lapped			
Description	Code	Price (Ex VAT)			
2 pair dia 8.5mm	546-220	1+	£2.19	50+	£1.97
4 pair dia 10.1mm	546-230	1+	£2.69	50+	£2.42
8 pair dia 13.8mm	546-240	1+	£4.75	50+	£4.28
12 pair dia 16.0mm	546-290	1+	£7.54	20+	£6.79
16 pair dia 17.5mm	546-250	1+	£9.63	20+	£8.67
24 pair dia 21.5mm	546-300	1+	£12.54	20+	£11.29

PRICE match
Studiospares will BEAT any genuine price from any UK competitor on any item or order.
details on page 318

Sommer Planet

FMC Double Foil Screened Unjacketed Multicore



Where multicore cable is terminated in multipin connectors and or stage boxes, then individual pairs need not be jacketed. This makes for a more compact cable and easily fits multiway plugs. This is a technically advanced cable where the Al/Pt-foil on the individual pairs does not come apart should heatshrink be pulled. The overall cable includes another foil shield and drain wire for added protection against magnetic fields.

Capacitance pF/m between conductors	Capacitance pF/m conductor to earth	DC Resistance of conductor Ω/m	No of strands and their diameters	Cross sectional area sq mm	Screening method	Overall dia mm
65	130	0.08	7 x 0.2mm	0.22	Double foil	-

Description	Code	Price (Ex VAT)					
8 + 2 Pair - Diameter 11.6mm	543-201	1+	£3.68	20+	£3.25	200+	£2.76
16 + 2 Pair - Diameter 14.4mm	543-151	1+	£6.24	50+	£5.63	200+	£4.97
24 + 2 Pair - Diameter 16.8mm	543-181	1+	£8.96	50+	£8.04	200+	£7.14
34 + 2 Pair - Diameter 18.6mm	546-850	1+	£9.92	20+	£8.93	100+	£7.94
48 + 2 Pair - Diameter 23.7mm	546-860	1+	£14.72	20+	£13.28	100+	£11.75

SOMMER CABLE

Foil screened multicore cable that can be cut and worked with ease.

This foil is attached to the outer jacket. For identification purposes individual pairs use colour coded conductors. Unlike competitive products, this multicore is not susceptible to cracking when flexed. Transmission losses are minimal through the use of relatively large diameter oxygen free copper conductors. The capacity between conductors and shield is minimised through a particularly effective dielectric. Coverage is 100%.

Studiospares Jacketed MKII

Multipair Cable



Like practically all premium grade multicores, the screening is lapped copper, not foil. This enhances the screening characteristics which had become necessary due to the increase in RF transmissions and communications. The lapped screening principle also provides greater flexibility and reliability since foil can break if the cable is repeatedly flexed in the same position. The conductors are based on a 0.14 sq mm of copper, the lapped screen on 32 strands of 0.12mm diameter copper.

Capacitance pF/m between conductors	Capacitance pF/m conductor to earth	DC Resistance of conductor Ω/m	No of strands and their diameters	Cross sectional area sq mm	Screening method	Overall dia mm
65	125	0.09	32 x 0.1mm	0.14	Lapped Copper	-

Description	Code	Price (Ex VAT)					
8 Pair - Diameter 15.8mm	548-350	1+	£1.88	50+	£1.69	200+	£1.51
8 Pair - Diameter 15.8mm Drum 100m	548-351	1+	£169.00	2+	£149.00		
16 Pair - Diameter 23mm	548-360	1+	£3.29	50+	£2.96	200+	£2.63
16 Pair - Diameter 23mm Drum 100m	548-361	1+	£282.00	2+	£249.00		
24 Pair - Diameter 26mm	548-370	1+	£4.78	20+	£4.33	100+	£3.84
32 Pair - Diameter 27mm	548-380	1+	£6.23	20+	£5.59	100+	£4.96

STUDIOSPARES

Focused on mechanical performance and effective screening at a competitive price.

Each pair is jacketed and clearly numbered. The cable is heavily sheathed overall by a specially formulated rubbery PVC with an average thickness of 2mm. The cable is packed with a cotton filler and cotton tape to enable the cable to retain its shape and resist becoming distorted when repeatedly wound and rewound. Manufactured to the ISO9001 standard.

DELIVERY BEFORE 10AM

no problem

SATURDAY DELIVERY

no problem

DELIVERY BEFORE NOON

no problem

ALL PRICES EXCLUSIVE OF VAT.

CABLE
Multicore Cable

CABLE

CONTINUED

Sommer Mistral

Double Foil Screened Jacketed Studio Multicore



An overall foil screen virtually stonewalls any unwanted magnetic and RF fields (excluded on 40 pair). It is secured to the outer jacket so is automatically removed when the jacket is stripped. Connection is via a twisted drain wire. The same applies to the foil screen surrounding individual pairs. Their jackets are pre-numbered and colour coded in groups of eight for rapid identification.

Capacitance pF/m between conductors	Capacitance pF/m conductor to earth	DC Resistance of conductor Ω /m	No of strands and their diameters	Cross sectional area sq mm	Screening method	Overall dia mm
65	130	0.08	7 x 0.2mm	0.22	Double foil	-

Description	Code	Price (Ex VAT)					
4 Pair - Diameter 11mm	546-310	1+	£2.76	20+	£2.41	100+	£2.07
8 Pair - Diameter 15mm	546-320	1+	£4.38	20+	£3.91	100+	£3.32
12 Pair - Diameter 16mm	546-330	1+	£6.44	20+	£5.73	100+	£4.91
16 Pair - Diameter 20mm	546-340	1+	£8.42	20+	£7.66	100+	£6.48
24 Pair - Diameter 24mm	546-350	1+	£12.46	20+	£11.06	100+	£9.52
32 Pair - Diameter 25.5mm	546-360	1+	£15.90	20+	£14.31	100+	£12.16
40 Pair - Diameter 26.5mm	546-870	1+	£20.44	20+	£18.40	50+	£15.37

SOMMER CABLE

The cable is very flexible and treadable using a rubber like jacket material.

Conductors and drain wires are tinned to protect against corrosion and oxidation.

Both DC and self capacity losses are held to new lows by the use of generous sized conductors and an advanced dielectric material. All copper strands are of oxygen free copper. Surge impedance 85 Ω .

CABLE
AES-EBU Digital Cable

Sommer Binary 234

AES-EBU DMX Cable



Binary 234 AES-EBU is purpose designed for 110 Ω applications.

- Dual 100% shielding with aluminium vapourised fleece and a counter rotating 100% copper spiral shield
- Extremely robust with an especially strong jacket
- Provides faultless data transfer across distances of up to 100m
- Overall diameter 6.4mm

Capacitance pF/m between conductors	Capacitance pF/m conductor to earth	DC Resistance of conductor Ω /m
63	115	0.053
No of strands and their diameters	Cross sectional area sq mm	Screening method
19 x 0.15mm	0.34	Copper+Alumin Fleece

Description	Code	Price (Ex VAT)			
Binary 234	546-170	1+	£1.49	100+	£1.14

AES-EBU Installation Cable



Designed essentially for the interconnection of static equipment within a studio complex.

- Miniature AES-EBU transmission cable with foil screening
- The cable parameters are such that the impedance is 110 Ω , which matches the AES-EBU requirements for data transmissions
- Diameter 3.4mm
- Sold by the metre

Description	Code	Price (Ex VAT)			
AES-EBU	543-340	1+	£0.45	30+	£0.39

CABLE
Studiospares DMX Cable

2-Core and 4-Core 1m



A high spec digital cable that can be relied on for performance and reliability. For mechanical protection the jacket is a flexible, antiabrasive and low corrosive gas emission PVC/NBR.

- Cable diameter 7.5mm
- Conductors tin copper wire
- Impedance < 80 ohms/km
- Capacity lead - lead 64pF/m; Capacity lead - shield 126 pF/M
- Velocity of propagation 60%
- Capable of withstanding temperatures ranging from -20 to 70 degrees; Conductors are twisted with aluminium foil

Description	Code	Price (Ex VAT)			
2-Core 1m	548-980	1+	£0.81	100+	£0.65
4-Core 1m	548-990	1+	£1.22	100+	£0.98

CABLE
Video Cable

Sommer Focusline 75 Ω

Video Cable



Sommer Focusline L presents an exact impedance of 75 Ω + 1%, which ensures there is no corruption of data.

- Used in video technology and data applications including word clock and suitable for mobile application and fixed installation
- The Green jacket colour indicates a surge impedance of 75 Ω
- Equipped with a soft, but still very durable jacket and a densely stranded copper shield made of oxygen free copper
- Suitable for installation in dry and damp rooms

Description	Code	Price (Ex VAT)			
Black	546-370	1+	£1.09	100+	£0.98
Green	546-380	1+	£1.09	100+	£0.98

CABLE
Speaker Cable

Sommer Meridian Halogen + Oxygen Free

Fireproof Speaker Cable



This series of Meridian Speaker Cables conforms to the most severe test, type C, where the risk of smoke or fire is a consideration. Meets DIN VDE0472 burning specification.

- Being Halogen free, in case of a fire, this cable will not develop any gases poisonous to humans, for example chloride. This is often a requirement in public buildings.
- Uses two conductors which are both Halogen and Oxygen free
- Very robust mechanical design

Conductor dia mm	Copper Strands	Jacket dia mm	AWG dia	Conductor Ω per Km	Insulating Ω per Km	Fire load per M
2x 2.5	140x 0.15	7.8mm	14	<7.8	>5M Ω	0.38kWh
2x 4.0	56x 0.30	9.5mm	12	<4.5	>5M Ω	0.54kWh
2x 6.0	84x 0.30	10mm	10	<3.3	>5M Ω	0.54kWh

Description	Code	Price (Ex VAT)			
2 x 2.5mm	546-530	1+	£2.20	100+	£1.98
2 x 4.0mm	546-540	1+	£3.49	100+	£3.14
2 x 6mm	546-550	1+	£5.24	100+	£4.72

THE website

Keep up to date with all the latest products and current prices on the Studiospares website!

check out www.studiospares.com

Europa Premium

Speaker Cable



The Premium cables provide an uncompromising level of performance. They are mechanically very robust and should withstand a lifetime of use, even possible abuse! Manufactured to the ISO9001 standard. Supplied on 100 metre drums or cut to length.

Description	Code	Price (Ex VAT)					
2 x 1.5mm ² - Diameter 6.5mm	548-310	1+	£0.49	50+	£0.44	200+	£0.39
2 x 2.5mm ² - Diameter 9.2mm	548-320	1+	£0.98	50+	£0.84	200+	£0.76
4 x 2.5mm ² - Diameter 12mm	548-330	1+	£1.57	50+	£1.38	100+	£1.20
6 x 2.5mm ² - Diameter 14mm	548-340	1+	£2.34	50+	£2.09	100+	£1.82
6 x 4.0mm ² - Diameter 16mm	548-740	1+	£4.42	50+	£3.86	100+	£3.32
8 x 2.5mm ² - Diameter 14mm	548-750	1+	£3.86	50+	£3.43	100+	£2.98
2 x 1.5mm ² Drum 100m	548-311	1+	£42.00	2+	£38.00		
2 x 2.5mm ² Drum 100m	548-321	1+	£76.00	2+	£72.00		
4 x 2.5mm ² Drum 100m	548-331	1+	£119.00	2+	£114.00		

A range of flexible speaker cables covering all powers and applications.

Kinking is unlikely due to a dense cotton filler that fills the gaps between the conductors and the outer jacket. As a guide we suggest 1.5mm for power levels under 100 watts or cable lengths under 20 metres. 2.5mm for powers over 100 watts or cable lengths over 20 metres.

Sommer Meridian

Twin Axial Speaker Cable



A highly flexible speaker cable with a matte rubber like jacket.

High bending cycles due to the dense stranding of the oxygen free cable. Conductors Red and Black. Black jacket

Description	Code	Price (Ex VAT)					
2 x 1.5mm ² Diameter 6.8mm	546-110	1+	£1.49	100+	£1.34	300+	£1.14
2 x 2.5mm ² Diameter 7.8mm	546-120	1+	£1.90	100+	£1.66	300+	£1.43
2 x 4mm ² Diameter 9.5mm	546-410	1+	£2.75	100+	£2.48	300+	£2.10
2 x 6mm ² Diameter 10mm	546-130	1+	£3.12	100+	£2.81	300+	£2.39

Europa High Performance

3mm Speaker Cable



Intended for installation purposes where its compact size is an issue. Anyone concerned about cable losses will note that 3sq mm conductors are thicker than household ring main wiring! Most high performance cables are 2.5sq mm. The flat figure of 8 construction eases problems of routing the cable in inaccessible areas and is easily concealed. The very high efficiency means, long cable runs need not result in power losses. Polarity is very apparent. On a price performance basis alone this product is without equal. Dims 4.5mm x 9mm.

Description	Code	Price (Ex VAT)			
3mm Cable	548-420	1+	£0.98	50+	£0.85
3mm Cable Drum 100m	548-421	1+	£76.00	50+	£73.30

Sommer Elephant

Speaker Cable



Used by countless touring bands and permanent installations.

It easily interfaces with Neutrik Speakon plugs, includes a large number of thin strands of Oxygen Free copper so retaining flexibility without compromising performance. The Black jacket is of a rubber like material which resists tearing, handles well and remains flexible.

Description	Code	Price (Ex VAT)					
4 x 2.5mm ² . Overall diameter 9.7mm. Conductors 50 x 0.25mm ² .	546-890	1+	£3.90	50+	£3.51	200+	£2.98
4 x 4mm ² + 2x 2.5mm ² . Overall dia. 14mm. Conductors 225 x 0.15mm ² and 141 x 0.15mm ² .	546-900	1+	£6.18	50+	£5.56	200+	£4.73
8 x 2.5mm ² . Overall diameter 12.5mm. Conductors 50 x 0.25mm ² .	546-930	1+	£6.50	50+	£5.85	200+	£4.97
8 x 4mm ² . Overall diameter 15.6mm. Conductors 128 x 0.2mm ² .	546-940	1+	£10.14	50+	£9.13	200+	£7.76

Speaker Cable

CABLE

CONTINUED

Transparent Speakerflex

1.3mm Speaker Cable



Inconspicuous around the studio.

- Configured 2x1.3 mm² for applications where power is below 100 watts or the cable run is under 20 metres
- Cable polarity is indicated by a Red line down one edge
- Diameter 3mm x 6mm
- Sold by the metre

Description	Code	Price (Ex VAT)		
Speakerflex	548-300	1+	£0.48	50+ £0.43
Drum 100m	548-301	1+	£40.00	2+ £37.00

White Economy Speakerflex

2.5mm Speaker Cable



A popular Speaker Cable through its substantial copper conductors and compact design.

- For flexibility the conductors include 79 strands of 0.2mm copper wire with a 25 amp continuous power rating
- Polarity is identified by a continuous Black line on one edge
- Diameter 6mm x 3.1mm
- Sold by the metre

Description	Code	Price (Ex VAT)		
Economy Speakerflex	543-141	1+	£0.82	50+ £0.75

Cable Identification

CABLE

Transparent Heatshrink

Cable Identification

A heavy duty grade of polyolefin heatshrink

Shrinks to 50% of its size when heated to 121 degrees C. High resistance to acids and oils. These sizes will meet 95% of all cable marking applications. Slides over and protects paper or biro marked cables.



Ideal for Cable marking

Code	Internal diameter	Shrinks to
535-700	4.7mm	2.4mm
535-710	9.5mm	4.8mm
536-880	12.7mm	6.4mm
535-830	19mm	9.5mm
536-730	25mm	12.5mm

Heatshrink diameter guide.

XLRs from Neutrik + Precision + Switchcraft use 25mm. **Code 536-730**

Jacks from Neutrik, Switchcraft, Studiospares budget use 19mm heatshrink. **Code 535-830**

Sold in 1metre lengths.

Description	Code	Price (Ex VAT)		
4.7mm	535-700	1+	£3.48	10+ £3.13
9.5mm	535-710	1+	£4.41	10+ £3.87
12.7mm	536-880	1+	£3.44	3+ £3.10
19mm	535-830	1+	£3.92	10+ £3.44
25mm	536-730	1+	£4.98	10+ £4.32

MORE PRODUCTS online

Mains Cable

CABLE

Mains Cable

2 Core and 3 Core



A range of mains cables manufactured in accordance with BSI approved to BS6500, also VDE approved.

Flexible PVC Sheath even down to -100C. 2 core oval, 3 core round. Copper conductors. Price per metre.

Description	Code	Price (Ex VAT)					
		1+	20+	100+	500+	1000+	
2 Core 0.75mm 6A Black	543-730	1+	£0.54	20+ £0.43	100+ £0.38	500+ £0.38	1000+ £0.38
2 Core 0.75mm 6A White	543-740	1+	£0.54	20+ £0.43	100+ £0.38	500+ £0.38	1000+ £0.38
3 Core 0.75mm 6A Black	543-750	1+	£0.62	20+ £0.50	100+ £0.43	500+ £0.43	1000+ £0.43
3 Core 0.75mm 6A White	543-760	1+	£0.62	20+ £0.50	100+ £0.43	500+ £0.43	1000+ £0.43
2 Core 1.5mm 15A Black	543-770	1+	£0.78	20+ £0.62	100+ £0.55	500+ £0.55	1000+ £0.55
2 Core 1.5mm 15A White	543-780	1+	£0.78	20+ £0.62	100+ £0.55	500+ £0.55	1000+ £0.55
3 Core 1.25mm 13A Black	543-790	1+	£1.19	20+ £0.95	100+ £0.83	500+ £0.83	1000+ £0.83
3 Core 1.25mm 13A White	543-800	1+	£1.19	20+ £0.95	100+ £0.83	500+ £0.83	1000+ £0.83

Write On Cable Marker

With Protective Film

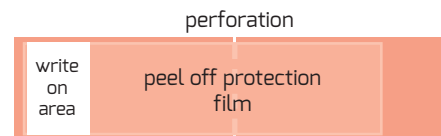

This system allows users to write their own markers for cables and pipes.

- Each strip on a standard card comprises a white PVC write on area, which can be automatically protected by wrapping the integral transparent film over the written area
- All strips include a break off tag to avoid adhesive contamination by the fingers
- Size 1: Overall marker length 75mm, maximum cable diameter 16mm, write-on area 22 x 25mm, 9 strips per card
- Size 2: Overall marker length 118mm, maximum cable diameter 28mm, write-on area 22 x 37mm, 4 strips per card.

Description	Code	Price (Ex VAT)		
75mm	534-030	1+	£2.26	10+ £1.94
118mm	534-040	1+	£1.98	10+ £1.73

FREE catalogue

Are you reading someone else's catalogue? Why not call us and order your own copy...

it's free!

SATURDAY DELIVERY no problem

DELIVERY BEFORE 10AM no problem

DELIVERY BEFORE NOON no problem

Hellerman Ovalgrip

Cable Markers

A convenient and permanent method of cable identification which looks professional, and needs no special tools.

- Fitted by pressing into a circular shape, then sliding over the cable end or terminal and releasing
- Colour coded for rapid identification
- H050 for cables 2.5mm to 3.6mm and H085 for cables 3.5mm to 6mm
- Sold in packs of approx. 50 markers
- Complete set of numbers 0-9 has a total of approx. 500 markers



Description	Code	Price (Ex VAT)			
H050 x50 0	535-300	1+	£0.69	2+	£0.62
H050 x50 1	535-310	1+	£0.69	2+	£0.62
H050 x50 2	535-320	1+	£0.69	2+	£0.62
H050 x50 3	535-330	1+	£0.69	2+	£0.62
H050 x50 4	535-340	1+	£0.69	2+	£0.62
H050 x50 5	535-350	1+	£0.69	2+	£0.62
H050 x50 6	535-360	1+	£0.69	2+	£0.62
H050 x50 7	535-370	1+	£0.69	2+	£0.62
H050 x50 8	535-380	1+	£0.69	2+	£0.62
H050 x50 9	535-390	1+	£0.69	2+	£0.62
H050 0-9 Ovalgrip	535-301	1+	£6.90	2+	£6.20
H085 x50 0	535-400	1+	£0.72	2+	£0.65
H085 x50 1	535-410	1+	£0.72	2+	£0.65
H085 x50 2	535-420	1+	£0.72	2+	£0.65
H085 x50 3	535-430	1+	£0.72	2+	£0.65
H085 x50 4	535-440	1+	£0.72	2+	£0.65
H085 x50 5	535-450	1+	£0.72	2+	£0.65
H085 x50 6	535-460	1+	£0.72	2+	£0.65
H085 x50 7	535-470	1+	£0.72	2+	£0.65
H085 x50 8	535-480	1+	£0.72	2+	£0.65
H085 x50 9	535-490	1+	£0.72	2+	£0.65
H085 0-9 Ovalgrip	535-401	1+	£7.20	2+	£6.50

Coloured PVC Insulation Tape

Fully flame retardant high grade tape which meets British Standards BS3924.

- 9 colours
- 19mm (0.75") wide
- Reel length 20m



Description	Code	Price (Ex VAT)			
Black	535-040	1+	£1.09	5+	£0.89
Red	535-220	1+	£1.09	5+	£0.89
White	535-290	1+	£1.09	5+	£0.89
Green	535-760	1+	£1.09	5+	£0.89
Green/Yellow	535-280	1+	£1.09	5+	£0.89
Grey	535-100	1+	£1.09	5+	£0.89
Blue	535-110	1+	£1.09	5+	£0.89
Brown	535-120	1+	£1.09	5+	£0.89
Yellow	535-130	1+	£1.09	5+	£0.89
Reel 4.5m Black	535-050	1+	£0.72	10+	£0.59

Expandable Braided Sleeving

Black and Grey



A useful aid to keeping cable looms tidy or to protect components, joints or plugs and sockets within a loom.

- The diameter can be expanded over any part or all of its length by up to 70%
- Note that the length supplied is measured at the minimum width
- Expanding the sleeving will reduce the length
- Sold by the metre.

Description	Code	Price (Ex VAT)			
8mm Grey	536-320	1+	£0.56	100+	£0.45
8mm Black	536-620	1+	£0.69	100+	£0.58
12mm Grey	536-330	1+	£0.85	100+	£0.76
12mm Black	536-630	1+	£0.99	100+	£0.89
16mm Grey	536-340	1+	£1.07	100+	£0.93
16mm Black	536-640	1+	£1.26	100+	£1.12
20mm Grey	536-350	1+	£1.45	50+	£1.24
20mm Black	536-650	1+	£1.63	50+	£1.42

Cable Harnessing

Cable Tie Wraps Sold Individually

In Velcro



A revised method of using Velcro to hold coils of cable in place.

This method first secures the tie to one end of the cable such that it cannot be lost. Then the wrap needs to be wrapped only once round the coil to make contact with itself. For absolute reliability, the Velcro is welded, not stitched. The grip is very very secure and has endless applications. These are sold in large quantities so the economies of scale are reflected in the price.

Width	Length	Tongue Colour	Body Colour	Code
20mm	200mm	Fluorescent	Black	537-640
20mm	300mm	Fluorescent	Black	537-650

Description	Code	Price (Ex VAT)			
20mm x 200mm	537-640	1+	£0.93	10+	£0.79
20mm x 300mm	537-650	1+	£0.99	10+	£0.89
16mm x 100mm	537-630	1+	£0.82	20+	£0.71

Cable Insulation

Hellerman Heatshrink

Black Heatshrink 2:1 Ratio

A heavy duty grade of polyolefin Heatshrink which shrinks to 50% of its size when heated to 121 degrees C.

- High resistance to acids, alkalis and oils
- Internal diameters to suit cable sizes from 1.7mm to 25mm
- Sold in 1 metre lengths.



Description	Code	Price (Ex VAT)			
3.2mm x 1	535-160	1+	£1.87	25+	£1.69
4.7mm x 1	535-170	1+	£1.73	25+	£1.44
6.4mm x 1	535-180	1+	£2.12	25+	£1.73
9.5mm x 1	535-190	1+	£2.58	25+	£2.28
12.7mm x 1	535-230	1+	£2.94	25+	£2.38
19mm x 1	535-200	1+	£3.26	25+	£2.44
25.4mm x 1	536-470	1+	£4.35	25+	£3.45

Klotz Cable Ties x5

A really useful pack of Velcro Cable straps each 225mm long.

- 5 colours, Black, Green, Red, Yellow and Blue
- Great for identifying bundles of Black cables



Description	Code	Price (Ex VAT)			
Coloured Cable Ties x5	544-610	1+	£5.52	10+	£4.97

Self-Amalgamating Tape

Tape which flows into itself when stretched and wrapped round cables and pipes etc.

- Forms a permanent waterproof seal
- More convenient than heatshrink
- Roll length 10m
- Width 25mm
- Colour Black

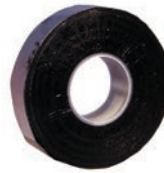

Description	Code	Price (Ex VAT)			
Tape	535-720	1+	£6.55	5+	£5.95

Studiospares Cable Tidy Hanger

Designed to accommodate leads from 5 - 13mm diameter.

- Wall mounted by 2 key shaped slots
- Can easily accept 20 leads
- Dimensions - 315 wide x mm x 53mm high x 64mm deep.



Description	Code	Price (Ex VAT)			
Cable Tidy Hanger	448-040	1+	£16.50	5+	£14.90

Heat Shrinkable Tape

Combines the advantages of heat shrinkable sleeving having the ability to be wrapped around irregular shapes and profiles.

- As the tape is wrapped around the component it will lightly adhere to itself
- Heat is then applied and the tape will shrink and present a fully moulded appearance
- Best results are at a temperature of 130 deg C
- Width 19mm. Reel length 50m



Astro-Grip 5m

Organiser Hook and Loop Tape

Great for organising cables and making them go where YOU want them to go.

- 1001 uses on stage and in the studio
- Cut and use whatever length is appropriate
- 5m length. Colour Black



Description	Code	Price (Ex VAT)			
Astro-Grip 5m	596-580	1+	£15.60	10+	£14.10

Description	Code	Price (Ex VAT)			
Heat Shrinkable Tape	538-010	1+	£7.96	2+	£7.22

Cable Harnessing

CABLE

CONTINUED

Floor Cable Protector

Cable Harnessing

Manufactured from a compound of natural and synthetic rubber.

CP1

Protector 60mm wide.
Hole bore 9mm wide x 8mm high.

CP2

Protector 127mm wide.
Hole bore 23mm diameter.

CP3

Protector 100mm wide.
Hole bore 50mm wide x 10mm high designed to accept one 10mm (max) cable and a few assorted mic cables.

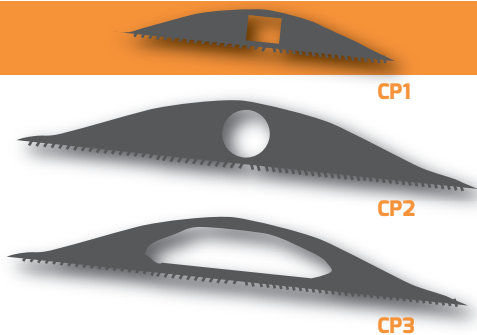

The mix is chosen to provide a product that is resistant to both weathering and ageing. The base has a serrated surface for enhanced grip with the floor. Cables can either be threaded through the bore hole or in situations where one end cannot be released, simply slit the bottom of the protector with a sharp knife such that it penetrates the bore hole and push the cable in sideways. Quoted dimensions are nominal. Colour Black. Sold by the 3 metre length.

Description	Code	Price (Ex VAT)			
CP1	406-271	1+	£13.10	5+	£11.50
CP2	406-281	1+	£45.20	5+	£41.90
CP3	406-291	1+	£25.30	5+	£22.90

Studiospares Retained Cable Wraps x10

Black



Secures any cable to anything.

- A flap first secures wrap to the cable then wraps round any pole, bar, microphone or other cable
- Wrap remains with the cable so will not drop off
- Maximum cable diameter 16mm; Width 16mm
- Useable active length 175mm to surround poles up to 52mm diameter
- Can be used as a conventional wrap

Description	Code	Price (Ex VAT)			
Cable Wraps x10	537-670	1+	£9.75	10+	£8.75

Studiospares Cable Wraps x10

Black



A conventional cable wrap with a thousand applications.

- Two lengths, 100mm and 250mm
- Width 21mm
- Colour Black

Description	Code	Price (Ex VAT)			
100mm x10	537-680	1+	£4.32	10+	£3.89
250mm x10	537-690	1+	£6.74	10+	£6.07

Velcro Cable Ties x5

Coloured

Multicoloured Cable Ties.

- 225mm long
- Pack of 5 Red, Blue, Green, Yellow, Black



Description	Code	Price (Ex VAT)			
Cable Ties x5	537-920	1+	£3.95	10+	£3.65

Cable Ties



Nylon Cable Ties with positive serrations on the inside to aid grip..

- Approximately 100 per pack
- 100mm is White, 340mm is Black.

Length of serrations	Max. bundle diameter	Width	Code
100mm	37mm	2.5mm	535-030
340mm	108mm	4.6mm	535-500

Description	Code	Price (Ex VAT)			
100mm	535-030	1+	£2.18	10+	£1.76
340mm	535-500	1+	£8.29	10+	£8.00

Hellermann Releasable Cable Ties

Easily fitted by hand or with pliers.

- Ties remain securely locked until the finger catch is released
- Approximately 100 per pack

Length of serrations	Max. bundle diameter	Width	Code
170mm	50mm	4.8mm	535-510
320mm	95mm	4.8mm	535-520

Description	Code	Price (Ex VAT)			
170mm	535-510	1+	£7.71	5+	£6.94
320mm	535-520	1+	£13.42	5+	£12.87

Hellermann Easy Release Cable Ties

At last, a really easily released cable tie, even with gloves on!

- Incorporates a patented pinch release mechanism designed to be quick and simple
- Ideal for temporary harnessing applications
- Minimum loop tensile strength is 13kg
- Manufactured from Nylon 66



Model	Description	Code
REZ200	Size 200mm x 4.8mm wide. 100 ties per pack.	538-260
REZ300	Size 300mm x 4.8mm wide. 100 ties per pack.	538-320

Description	Code	Price (Ex VAT)			
REZ200	538-260	1+	£10.54	10+	£9.49
REZ300	538-320	1+	£14.72	10+	£13.25

UltraTech Ultra-Sidewinder Cable Protector

NEW

The design articulates left and right - allowing the system to turn corners and adapt to the layout of the room.

- Cables can be left in the system for ultimate portability
- Can be left in place indefinitely
- Flexible design - curves, corners and s-curves are easily made
- Maintains a completely flat profile
- Modular design makes it easy to reconfigure and repair
- Easily replace targeted segments while the cable remains connected
- Simple "snap in" assembly - no tools or cutting required.
- Fully customisable length.



Description	Code	Price (Ex VAT)			
91cm Black	470-530	1+	£24.79	2+	£23.50
91cm Yellow/Black	470-531	1+	£24.79	2+	£23.50
91cm Brown	470-532	1+	£24.79	2+	£23.50

Adam Hall Defender Mini

With a 2 ton load capacity the Mini is no lightweight shirker.

- Length 1000mm x 290mm wide x 48mm
- Number of channels 3; Channel width 35mm, heights 30 + 35 + 30mm
- Polyurethane with a shore hardness of 88 ± 4
- Patented self-cleaning hinged closure
- Bottom has a non slip surface.
- Resists oils, acids and petrol
- DEKRA certified - Certified product safety



Description	Code	Price (Ex VAT)			
Mini Yellow Lid	470-480	1+	£74.17	10+	£69.80
Mini Black Lid	470-485	1+	£74.17	10+	£69.80

Adam Hall Defender Nano

For indoor applications, where its smaller size is more important and is less of a problem for wheelchair users.

- 2 ton load capacity but is not interlocking
- Same characteristics as the Mini but with a slightly different specification
- Length 1000mm x 28mm wide x 32 mm high
- Channels - 6 each with a diameter of 18mm

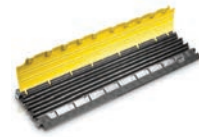

Description	Code	Price (Ex VAT)			
Nano Yellow Lid	470-490	1+	£66.66	10+	£63.30
Nano Black Lid	470-495	1+	£66.66	10+	£63.30

MORE PRODUCTS online

Adam Hall Defender Office

For office applications where the 2 ton capacity is unnecessary.

- Partial interlocking. (Slide lid along by 10cm)
- Defender Office only differs from the above on the following points
- Length 870mm Width 120mm, Height 21mm. Colour Black
- Channels 4; Diameters 10mm, 12mm, 12mm, 10mm
- End Ramp (85168) Code 470-502 which needs the lid to be offset by 100mm to lock into the adjacent piece



Description	Code	Price (Ex VAT)			
Office	470-500	1+	£26.67	10+	£24.50
90 degree Curve	470-501	1+	£9.99	10+	£9.35
End Ramp	470-502	1+	£9.16	10+	£8.46

Defender Compact

For situations where cables need to be protected from cars and feet.

- The arrangement of supports moulded into the bottom allows it to be laid over a run of cables
- Manufactured from Black polyurethane with a ribbed anti slip surface
- The three larger cable channels are 29mm wide and up to 27mm deep
- The three larger cable channels are 29mm wide and up to 27mm deep
- The unit is 800mm long, 440mm wide and 37mm high



Description	Code	Price (Ex VAT)			
Defender Compact	460-270	1+	£41.70	2+	£39.70

Hellermann Kanaflex



A patented design for panel trunking that increases the number of cables that can be routed via a small area.

- Cables are easily inserted through the central crossed fingers by simply pushing downwards
- Manufactured from Thermoplastic polymer, flame resistant to UL94 V0
- Mounting holes and adhesive sticky backed for simple fixing
- Ends designed to butt together so runs can be continuous
- 0.5m lengths

Description	Code	Price (Ex VAT)			
20mm x 20mm	538-240	1+	£2.19	5+	£1.95
40mm x 40mm	538-250	1+	£4.30	5+	£3.65

Pliozip

Protection Tubing

For holding and protection of cable harnesses in fixed or mobile electrical installations, especially in mechanical engineering and panel construction.

- Large flexibility : very good bending radius
- Possibility to bypass cables.
- Tubing easily removable and reusable



Description	Code	Price (Ex VAT)			
8mm 100m Black	534-120	1+	£82.50	2+	£77.50
15mm 50m Black	534-130	1+	£62.50	2+	£58.70
20mm 30m Black	534-140	1+	£58.30	2+	£55.20
25mm 20m Black	534-150	1+	£55.00	2+	£52.50
32mm 15m Black	534-160	1+	£65.00	2+	£62.20

Pliozip Mounting Tool

Protection Tubing Tool

A tool adapted to each protection tubing diameter facilitates the insertion of cables.

- Simple and easy to use
- This ergonomic tool is provided with a clip system



Description	Code	Price (Ex VAT)			
8mm	534-170	1+	£2.16	2+	£1.95
15mm	534-180	1+	£2.76	2+	£2.38
20mm	534-190	1+	£4.06	2+	£3.65
25mm	534-200	1+	£3.48	2+	£3.14
32mm	534-210	1+	£4.48	2+	£3.97

RFI Suppression

RFI Ferrite Clamps

Interference Suppressing

Designed to reduce electromagnetic interference from being induced or radiated from cables.

- The clamshell package protects the ferrite and ensures that once fitted the unit will not slip
- Supplied in two halves that snap together so plugs do not have to be first removed
- For maximum effect place over the cable as close to the equipment's INPUT as possible
- Particularly relevant for low level microphone signals



Description	Code	Price (Ex VAT)			
10mm Ferrite	537-940	1+	£1.98	10+	£1.78
13mm Ferrite	537-950	1+	£2.34	10+	£2.11

Cable Glands

Solid Metal Cable Glands

Made from nickel plated brass, these Cable Glands provide a firm grip on the cable with a saddle clamp.

- Panzer Gauge (PG) threads 8mm long
- This thread is used with Harting Connectors
- 16-20mm version is threaded 21PG and 18-27mm version is threaded 29PG
- Length of thread 8mm
- Use 28.5mm diameter hole for 21PG and 37mm diameter hole for 29PG



Description	Code	Price (Ex VAT)			
Gland 16-20mm	402-170	1+	£4.30	2+	£3.75
Metal Nut 21PG	402-190	1+	£1.15	2+	£0.99
Gland 18-27mm	402-200	1+	£8.20	2+	£7.50
Metal Nut 29PG	402-220	1+	£1.63	2+	£1.31

Solid Metal Cable Glands + Seal

Provides positive cable retention and protection.

- Intended for cable snakes, free standing or wall mounted applications
- Seal prevents the ingress of moisture and dust
- Thread length 13mm
- Made from nickel plated brass, with both a conventional neoprene compression gland plus a saddle clamp



Diameter	Description	Code
8-11mm	Requires a 20mm securing nut	404-230
12-14mm	Requires a 20mm securing nut	404-240
15-20mm	Requires a 25mm securing nut	404-260

Description	Code	Price (Ex VAT)			
Gland 8-11mm	404-230	1+	£7.22	2+	£6.52
Metal Nut 20mm	404-270	1+	£1.04	2+	£0.89
Gland 12-14mm	404-240	1+	£7.88	2+	£7.10
Metal Nut 20mm	404-270	1+	£1.04	2+	£0.89
Gland 15-20mm	404-260	1+	£9.62	2+	£8.72
Metal Nut 25mm	404-280	1+	£1.53	2+	£1.34

Bell Mouth Cable Glands

Intended for any portable cable snakes where the cable entering the stage box will be flexed or bent round to small a radius causing a foil screen to rupture.

- Reduces the likelihood of the cable being over exerted at its most vulnerable point, as it enters the stage box
- Manufactured from nickel plated brass with a saddle type cable grip
- Threads Panzer gauge (PG).
- Cables 18mm - 28mm diameter
- Thread type 29PG, fits hole diameter 37mm



Description	Code	Price (Ex VAT)			
Gland 18-28mm	402-210	1+	£7.70	2+	£7.15
Metal Nut 29PG	402-220	1+	£1.63	2+	£1.31

Nylon Gland With Strain Relief

A coiled strain relief reduces the wear and tear on conductors at the vulnerable point where it leaves the gland.

- The problem is best overcome by the spiral spring gland which spreads any bending over a greater radius
- The internal neoprene seal is waterproof and dust proof
- Securing nut sold separately



Size	Description	Code
6-12mm	thread size is 20mm diameter by 13mm long.	404-010
20mm	nut for above.	404-090
10-14mm	thread size is 25mm diameter by 13mm long.	404-820
25mm	nut for above.	404-220

Description	Code	Price (Ex VAT)			
Gland 6-12mm	404-010	1+	£1.99	5+	£1.69
Nylon Nut 20mm	404-090	1+	£0.42	5+	£0.34
Gland 10-14mm	404-820	1+	£1.99	5+	£1.84
Nylon Nut 25mm	404-220	1+	£0.64	4+	£0.52

1000s of products Available from stock!

VISIT our trade counter
You'll get friendly advice and immediate access to 8000+ product lines!

CABLE

Cable Testers

Studiospares Ultimate Cable Tester

With Tester Case

Easily the most relevant cable tester for the Pro Audio Industry.

The Ultimate Cable Tester covers the following: XLR 3 and 5 pin, Jack, Mini Jack, Phono, DIN/IEC 3, 5, 7 and 8 pin, Speakon/Speakloc 2, 4, and 8 pin and Cat 5. LEDs confirm continuity and phase connection. Also indicates ground to shell short circuit. Complete with probes and battery. All metal construction.

Dimensions - 40mm height x 88mm width x 188mm depth.
All metal padded case with latch. Space for probes.
Dims mm 207 x 159 x 77.

An essential piece of kit for every engineer.



	UCT100	UCT50	UCT100U	UCT100M
XLR 3 pin female	✓	✓	✓	✓
XLR 5 pin female	✓		✓	✓
XLR 3 pin male	✓	✓	✓	✓
XLR 5 pin male	✓		✓	✓
Jack Unbalanced	✓	✓	✓	✓
Jack Balanced	✓	✓	✓	✓
Mini Jack 3.5mm	✓		✓	✓
Phono (RCA)	✓	✓	✓	✓
Speakon/Speakloc 4 way	✓	✓	✓	✓
Speakon/Speakloc 8 way	✓	✓	✓	✓
Banana Speaker	✓	✓	✓	✓
Small DIN				✓
MIDI	✓	✓	✓	✓
MIDI/DIN 3 5 7 8 pin	✓	✓	✓	✓
USB			✓	
Cat 5	✓		✓	
Phase testing	✓	✓	✓	✓
Continuity probes	✓	✓	✓	✓
Battery	✓	✓	✓	✓

Description	Code	Price (Ex VAT)
Ultimate Cable Tester	458-260	£20.83
All Metal Tester Case	458-550	£11.70
Cable Tester + Case	458-265	£28.33
UCT50	458-830	£16.70
UCT100M	458-840	£25.50
UCT100U	458-850	£25.50

Cable Tester + Case



STUDIOSPARES

Behringer CT100

Cable Tester

An intelligent, CPU-controlled tester which accepts virtually any connector type: XLR, mono and stereo Jacks, Phonos and MIDI.

- LED display shows which input pin is connected to which output pin
- Separate shield and phantom power LED's
- Installed cable test mode
- Test tone generator operating at 1kHz and 440Hz
- Requires two AA batteries (Studiospares code 402-520)



Description	Code	Price (Ex VAT)
CT100	370-030	1+ £20.82 2+ £19.50

Palmer AHMCT8

Multipurpose Cable Tester

Any wire of cable with any plug can be tested using the supplied test cables.

- Test results are shown visually by LED and audibly by buzzer
- The (supplied) 9V battery is installed in a slide-in compartment for easy replacement
- Connectors: Speakon, XLR male, XLR female, Phono, DIN, 1/4" Jack, Banana



Description	Code	Price (Ex VAT)
AHMCT8	535-820	1+ £56.50 2+ £54.50

CABLE

Cable Drums

Empty Cable Reel

MCR-1

For cables with a length of up to 80m of mic cable.

- Steel tube base with ergonomic plastic carrying handle
- Plastic reel 290mm with locking device
- Dimensions: 290x365x190mm
- Weight: 1.1kg



Description	Code	Price (Ex VAT)
Empty Drum	255-350	1+ £20.80 2+ £18.80

WANT a job?

Are you looking for a stable and rewarding career?

Studiospares are constantly expanding. We require additional staff for a variety of positions, working in a very congenial atmosphere. Practical experience of recording and/or live sound engineering would be preferable.

send in your CV in the first instance

FOR fax orders

Use our fax number...

020 8450 4390

1000s of products

Available from stock!

VISIT our trade counter

You'll get friendly advice and immediate access to 8000+ product lines!

Studiospares Empty Cable Drums

All Steel Construction

Two versions of a roll around Cable Drum with heavy duty wheels, not plastic castors.

Includes a friction brake to hold the drum in position for transportation.

With termination panel

Side panel includes 24 female XLR sockets.

Without termination panel

Side panel includes 24 female XLR sockets.



Description	Code	Price (Ex VAT)			
Cable Drum with panel	548-550	1+	£94.50	2+	£88.20
Cable Drum without panel	548-560	1+	£94.50	2+	£88.20



Space Saving Mic/Wall Box 8/16 Way

Takes up far less space than other products and favoured by studios who have heavy "people traffic" moving around the studio.

- Leads protrude less
- Designation numbers easier to see
- 8 way top plate reversible Numbering 1-8 and 17-24 on reverse side
- 16 way top plate reversible. Numbering 17-32 on reverse side.
- 25mm cable access knockouts each end and at the rear
- Rear keyhole and 4 round hole mounting
- Length 8way 285mm, 16way 550mm



Description	Code	Price (Ex VAT)			
8 Way	405-350	1+	£8.32	2+	£7.66
16 Way	405-370	1+	£11.88	2+	£10.77

Lock N Roll Cable Drum

A simple and ingenious way to store leads without finding them tangled when you need them quickly.

- The connectors both protrude through the reel and are held in place by the moulded in cable clips
- The drum will also hold a mains lead which has a central moulded in receptacle
- Can hold 4 leads or cables
- Storage capacity 20 metres of mic cable



Studiospares Stage Boxes

A range of pre loaded stageboxes designed to live under musicians' feet and withstand the rigours of the road.

- Includes a recessed round bar across the upper end for carrying purposes
- Pre loaded with all sockets, a wire strain relief and a metal gland
- The sockets are metal, not plastic and easy to solder



Description	Code	Price (Ex VAT)			
8 XLR ins+4 Jack Rtms	548-660	1+	£33.90	2+	£31.90
12 XLR ins+4 Jack Rtms	548-670	1+	£35.50	2+	£33.20
16 XLR ins+4 Jack Rtms	548-680	1+	£38.60	2+	£36.20
24 XLR ins+4 Jack Rtms	548-690	1+	£49.90	2+	£47.40
8 XLR ins+4 XLR Rtms	548-700	1+	£32.70	2+	£29.90
12 XLR ins+4 XLR Rtms	548-710	1+	£34.30	2+	£32.20
16 XLR ins+4 XLR Rtms	548-720	1+	£37.50	2+	£34.90
24 XLR ins+4 XLR Rtms	548-730	1+	£48.90	2+	£46.30

Floor Boxes

Floor Boxes

A range of heavy duty retractable floor termination boxes.

- Die cast box has a hinged centre section that springs up into place when the sliding catch is released
- Silver surface with a hammer style finish
- XLR connectors are mounted in normal D style cut outs so other sockets can be substituted
- Floor cut out dimensions, 170mm x 86mm with a corner radius of 200mm



Description	Code	Price (Ex VAT)			
4x XLR Female	548-500	1+	£19.70	3+	£17.80
4x XLR Male	548-510	1+	£19.70	3+	£17.80
2x XLR Fe + 2x XLR Ma	548-520	1+	£19.70	3+	£17.80
2x XLR Fem + 2 Jack	548-530	1+	£19.70	3+	£17.80
2x XLR Male + 2 Jack	548-540	1+	£19.70	3+	£17.80

Stage Boxes

Behringer S16

Digital Snake



NEW LOWER PRICE



The S16 provides 16 fully programmable, remotely controllable high-end mic preamps plus 8 analog, balanced XLR returns at the stage end, and connects to the FOH via a single Cat5e cable without the need for a dedicated router. Klark Teknik, a longtime industry leader in the development of high-end digital audio processing, provided the SuperMAC technology that made all of this possible & Behringer made it affordable.

Digital I/O Box with 16 Remote-Controllable Midas Preamps, 8 Outputs and AES50 Networking.

Description	Code	Price (Ex VAT)			
S16	383-830	1+	£515.83	2+	£507.50

Takes the burden out of connecting your FOH (Front of House) console with the talent.

CABLE

Mic Wall Boxes/Stage Boxes

Studiospares Mic Wall/Stage Boxes

Easily the most effective.

Pre-drilled for cable snakes or wall mounting. All versions are of steel 1.4mm thick, of substantial construction and smart appearance. No unsightly mounting holes. By first mounting the back plate on the wall, problems of alignment, access to the mounting holes, wiring access etc are totally eliminated. Finish Black stove enamelling for maximum durability. Four 6mm holes for wall fixing plus a 25mm centrally placed hole for rear cable entry. For external cable entry (snakes) two holes, 25mm and 37mm are located on the lower edge of the socket panel. These cover a wide range of multiway diameters. See Glands section for suitable cable entries. Three versions:

16 identical XLR holes + 8 Jack

with D type cut outs capable of accepting both male and female XLRs (also Neutrik Jack sockets). Plus 8 holes 11mm diameter for mounting chassis type Jack sockets for headphone or auxiliary input/outputs. Size 265 Wide x 170 High x 45mm Deep. A 25mm hole is located on the lower edge of the socket panel.

Description	Code	Price (Ex VAT)			
16 XLR + 8 Jack Black	401-381	1+	£23.17	2+	£21.50

24 identical XLR holes

with D type cut outs capable of accepting both male and female XLRs (also Neutrik Jack sockets). 265 Wide x 170 High x 45mm Deep.

Description	Code	Price (Ex VAT)			
24 XLR Black	405-730	1+	£28.70	2+	£25.90

8 XLR holes + 4 Jack

with D type cut outs for male or female sockets plus 4 holes 11mm diameter for headphones or auxiliary inputs/outputs. 135 Wide x 170 High x 45mm Deep.

Description	Code	Price (Ex VAT)			
8 XLR + 4 Jack Black	401-561	1+	£17.92	2+	£16.58

1, 2, 4 and 8 Way Boxes

Description	Code	Price (Ex VAT)			
1 XLR hole 32W x 40H x 31D	403-020	1+	£9.82	5+	£8.82
2 XLR hole 64W x 40H x 31D	403-030	1+	£12.38	5+	£11.14
4 XLR hole 128W x 40H x 31D	403-040	1+	£14.72	5+	£13.25
8 XLR hole 260W x 50H x 31D	403-070	1+	£14.58	5+	£13.75
Optional 50 Pozzi Screws	440-430	1+	£2.83	2+	£2.28



The UK's most popular wall boxes



1, 2, 4 and 8 Way Boxes

STUDIOSPARES

DELIVERY BEFORE 10AM
no problem

SATURDAY DELIVERY
no problem

DELIVERY BEFORE NOON
no problem

CONNECTORS

Multiway Connectors

D-Sub Connectors



Female Male Screwlock cover

A popular range of high quality D Sub connectors with Gold plated contacts and solder bucket terminations.

- Both plug and socket shells are plated to allow full grounding integrity for EMI/RFI shielding
- Connector can be used as a chassis connector or as a line plug with the screwlock cover attached

Description	Code	Price (Ex VAT)			
9 way Male Plug	577-230	1+	£0.65	4+	£0.55
15 way Male Plug	577-240	1+	£0.67	4+	£0.57
25 way Male Plug	577-250	1+	£0.74	4+	£0.64
9 way Female Plug	577-260	1+	£0.67	4+	£0.57
15 way Female Plug	577-270	1+	£0.71	4+	£0.63
25 way Female Plug	577-280	1+	£0.74	4+	£0.64
37 pin Socket	578-530	1+	£1.44	4+	£1.35
9 way Plastic Cover	577-290	1+	£1.05	4+	£0.92
15 way Plastic Cover	577-300	1+	£1.09	4+	£0.95
25 way Plastic Cover	577-310	1+	£1.13	4+	£0.99
37 way Plastic Cover	578-540	1+	£1.19	4+	£1.04
9 way Metal Cover	597-660	1+	£1.64	4+	Ex.xx
15 way Metal Cover	597-670	1+	£1.97	4+	Ex.xx

EDAC Multiway Connectors

Universal plugs or sockets may be cable or chassis mounted.

- Locking actuator for positive retention
- Gold pins for solder or crimp connection
- Pins are identical for plugs or sockets
- Metal covers are dual entry through top or side and fit plug or receptacle
- As used by major mixer manufacturers
- Metal locating pins or sleeves determine "Plug Male" or "Socket Female" respectively



This version of the Edac 516 has the actuating screw attached to the plug. The receptacle includes the threaded locking nut.

Description	Code	Price (Ex VAT)			
20 pin + act Plug	575-670	1+	£3.96	2+	£3.79
38 pin + act Plug	575-680	1+	£5.96	10+	£5.44
56 pin + act Plug	575-690	1+	£6.26	10+	£5.53
90 pin + act Plug	575-700	1+	£12.91	10+	£12.49
120 pin + act Plug	575-710	1+	£15.50	10+	£14.20
20 pin Reception + Nut	575-720	1+	£3.92	10+	£3.46
38 pin Reception + Nut	575-730	1+	£4.72	10+	£4.13
56 pin Reception + Nut	575-740	1+	£4.92	10+	£4.46
90 pin Reception + Nut	575-750	1+	£5.92	10+	£5.52
120 pin Reception + Nut	575-760	1+	£7.75	10+	£6.95
20 pin MTL Cover	575-770	1+	£5.80	10+	£5.35
38 pin MTL Cover	575-780	1+	£6.92	10+	£6.10
56 pin MTL Cover	575-790	1+	£7.92	10+	£7.25
90 pin MTL Cover	575-800	1+	£8.42	10+	£7.40
120 pin MTL Cover	575-810	1+	£12.25	10+	£11.40
Solder Contacts x100	575-820	1+	£17.65	10+	£16.95
Crimp Contacts x100	577-860	1+	£19.50	10+	£18.50
Edat Eject Tool	537-860	1+	£39.50	2+	£35.90

MORE PRODUCTS online

CONNECTORS

XLR Connectors

Switchcraft Quicktwist XLR

New highly innovative two part design.

- Nickel plated diecast zinc body with twist on handle/strain relief
- Silver contacts
- Quick assembly
- UK'S LOWEST PRICE



Description	Code	Price (Ex VAT)			
Quicktwist Male	578-670	1+	£1.81	50+	£1.61
Quicktwist Female	578-680	1+	£1.93	50+	£1.71

Right Angle XLR Male/Female

Nickel 3 Pin Right Angled XLR Male Plug With Cable Protector and Solder Terminals.

- Right angled
- Nickel coloured metal case
- Cable protector
- Solder terminals



Description	Code	Price (Ex VAT)			
Right Angled Male	597-020	1+	£1.85	5+	£1.66
Right Angled Female	597-030	1+	£1.75	5+	£1.58

Speaker XLR Plugs

Dramatically increases the power an XLR can handle.

- Gold plated pins
- Max cable diameter 12mm
- Conductors are held by screws and not soldered
- Very substantial
- Manufacturer works in accordance with ISO9001



Description	Code	Price (Ex VAT)			
3 Pin Female	568-610	1+	£1.64	20+	£1.44
3 Pin Male	568-620	1+	£2.13	20+	£1.86

Switchcraft XLR

A premium grade product of world renown from America's favourite military and audio plug manufacturer.

- Very popular for PA which demands absolute reliability whatever the situation
- Frequently imitated but never bettered
- Lifetime guarantee



Description	Code	Price (Ex VAT)			
3 Pin Female	575-630	1+	£2.96	50+	£2.58
3 Pin Male	575-640	1+	£2.03	50+	£1.79

Precision Audio XLR

XLR Connectors

Precision die cast body with nickel on copper plated contacts.



Female barrel includes raised pressure points to ensure tight mating and a rubber mating gasket. Cable is anchored by a (slit) chuck when the top is screwed down. 4 piece design for rapid assembly. No screws.

Max/min cable diameter 7mm/4.5mm. Black gland. Manufactured to ISO9001 standard.

Description	Code	Price (Ex VAT)					
XLR Female	568-000	1+	£0.89	50+	£0.78	100+	£0.49
XLR Male	568-010	1+	£0.89	50+	£0.78	100+	£0.49

COLOURED GLANDS

Description	Code	Price (Ex VAT)					
Gland Red	568-240	1+	£0.28	10+	£0.24	50+	£0.20
Gland Blue	568-250	1+	£0.28	10+	£0.24	50+	£0.20
Gland Green	568-260	1+	£0.28	10+	£0.24	50+	£0.20
Gland Yellow	568-270	1+	£0.28	10+	£0.24	50+	£0.20

Neutrik NC3FRX/NC3MRX

Connector can be set at 5 different angles.

- Max cable diameter 7.5mm
- 3 pin only
- Insert interchanges with straight NC series should a 4, 5 or 6 pin version be required
- 20mm wide.



Description	Code	Price (Ex VAT)			
Nickel 3 Pin Female	581-620	1+	£5.63	50+	£4.95
Nickel 3 Pin Male	581-630	1+	£4.97	50+	£4.32
Black 3 Pin Female	581-640	1+	£6.07	50+	£5.33
Black 3 Pin Male	581-650	1+	£5.60	50+	£4.92

Precision Plus XLR

A two part solid die cast aluminium shell with a satin chrome finish, designed to last a lifetime.

- Classic construction. Only 4 parts.
- Solder buckets take solder easily.
- Positive cable clamp chuck.
- Frequently used on high end leads.
- Ring colours Orange, Blue, Green, Yellow, Red and White.



Description	Code	Price (Ex VAT)			
XLR Female	568-720	1+	£1.35	50+	£1.18
XLR Male	568-730	1+	£1.25	50+	£1.09
6 coloured rings	568-760	1+	£0.25	50+	£0.20

ALL PRICES EXCLUSIVE OF VAT.

CONNECTORS

XLR Connectors

CONTINUED

Neutrik NCXX

XLR Connectors

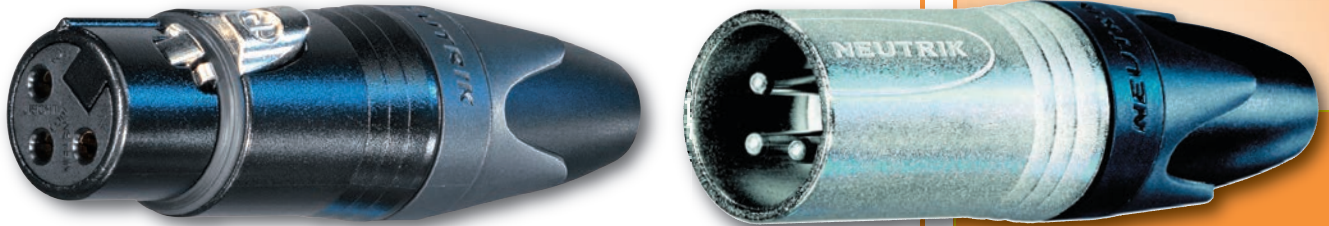

Description	Code	Price (Ex VAT)					
NC3FXX Silver 3 Pin Female	575-480	1+	£2.88	50+	£2.54	100+	£2.16
NC3FXX-BAG Black 3 Pin Female	578-140	1+	£3.08	50+	£2.71	100+	£2.31
NC4FXX Silver 4 Pin Female	575-930	1+	£4.51	50+	£3.97	100+	£3.38
NC5FXX Silver 5 Pin Female	575-980	1+	£6.69	50+	£5.88	100+	£4.88
NC6FXX Silver 6 Pin Female	575-960	1+	£8.20	50+	£7.18	100+	£6.15
NC3MXX Silver 3 Pin Male	575-490	1+	£2.44	50+	£2.15	100+	£1.83
NC3MXX-BAG Black 3 Pin Male	578-150	1+	£2.78	50+	£2.45	100+	£2.08
NC4MXX Silver 4 Pin Male	575-940	1+	£3.38	50+	£2.98	100+	£2.54
NC5MXX Silver 5 Pin Male	575-950	1+	£5.57	50+	£4.89	100+	£4.17
NC6MXX Silver 6 Pin Male	575-970	1+	£6.94	50+	£6.10	100+	£5.22



The NCXX series from Europe's largest manufacturer.

Simple assembly. No screws. Quality at a modest price. This is easily the most popular XLR worldwide.

Coloured boots and rings available (on this page).

3 pin versions also available in Black.

NC3FXX B/ NC3MXX B

Neutrik Gold

Popular through AES/EBU requirements.

- Black matte body otherwise identical to NC3FXX (see above) but with Gold plated pins.



Description	Code	Price (Ex VAT)			
3 Pin Female	575-580	1+	£3.77	50+	£3.32
3 Pin Male	575-590	1+	£3.06	50+	£2.69

Switched Mic On-Off XLR

Incorporates a positive click stop rotary switch labelled "on" and "off" shorting pins 2 and 3.



Description	Code	Price (Ex VAT)			
NC3FXS	577-500	1+	£8.84	10+	£7.73

Neutrik Coloured Boots

The NC-XX series has optional coloured boots.

- Order using 578-06x
- The last digit determines the colour
- Eg a blue boot order as Code 578-066



Coloured Rings

The NC-XX series has optional coloured rings.

- Order using 578-07x
- The last digit determines the colour
- Eg a blue ring order as Code 578-072



Brown = 1, red = 2, orange = 3, yellow = 4, green = 5, blue = 6, violet = 7, grey = 8, white = 9.

XXCR Translucent Boot/Rings

For customised labelling.

Description	Code	Price (Ex VAT)			
Boot	578-06x	1+	£0.57	10+	£0.49
Ring	578-07x	1+	£0.20	10+	£0.17
Rings Bag of 6 Colours	568-760	1+	£0.25	10+	£0.20
Translucent Ring	581-550	1+	£0.45	10+	£0.40

WANT a job?

Are you looking for a stable and rewarding career?

Studiospares are constantly expanding. We require additional staff for a variety of positions, working in a very congenial atmosphere. Practical experience of recording and/or live sound engineering would be preferable.

send in your CV in the first instance

VISIT our trade counter

You'll get friendly advice and immediate access to 8000+ product lines!

CONNECTORS

XLR Chassis Connectors

Precision Chassis XLR Silver

A precision die cast chassis socket with nickel on copper plated contacts for extended life.

- Counter sunk fixing holes
- Manufactured to the ISO9001 standard



Description	Code	Price (Ex VAT)			
3 Pin Silver Female	568-020	1+	£0.99	50+	£0.74
3 Pin Silver Male	568-030	1+	£0.95	50+	£0.70

Precision Chassis XLR Black

A precision die cast chassis socket with nickel on copper plated contacts for extended life.

- Countersunk fixing holes
- Manufactured to the ISO9001 standard



Description	Code	Price (Ex VAT)			
3 Pin Black Female	568-200	1+	£0.99	50+	£0.79
3 Pin Black Male	568-210	1+	£0.95	50+	£0.75

Plastic Chassis XLR

The same sockets are used by the tens of thousands on imported equipment.

- Absolute reliability
- Lifetime guarantee



Description	Code	Price (Ex VAT)			
3 Pin Plastic Female	568-220	1+	£0.58	50+	£0.49
3 Pin Plastic Male	568-230	1+	£0.58	50+	£0.49

Neutrik NC3FD-LX/NC3MD-LX

3 Pin XLR Chassis Connector

Fits D type cut out.

The DLX series features a compact all metal housing with an ingenious duplex ground contact, which offers excellent RF protection and shielding.

Reliability, robustness and dependability derive from incorporating the latest components from the well proven XX and A series connectors.

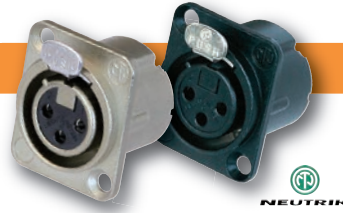

Description	Code	Price (Ex VAT)					
3-Pin Silver Female	511-120	1+	£3.08	10+	£2.59	50+	£2.29
3-Pin Black Female	511-130	1+	£3.18	10+	£2.68	50+	£2.38
3-Pin Silver Male	511-140	1+	£2.79	10+	£2.39	50+	£2.09
3-Pin Black Male	511-150	1+	£3.02	10+	£2.57	50+	£2.27
3-Pin Female with M3 Threaded Holes	511-160	1+	£3.18	10+	£2.69	50+	£2.41
3-Pin Male with M3 Threaded Holes	511-170	1+	£2.91	10+	£2.49	50+	£2.18

Neutrik NC3FDL1/NC3MDL1

3 Pin XLR Chassis Connector

Fits D type cut out.

- Same cut out for Male and Female
- Die cast base
- Includes a latch for reliable retention



Description	Code	Price (Ex VAT)			
Silver Female	575-060	1+	£3.32	50+	£2.91
Black Female	577-760	1+	£3.51	50+	£3.08
Silver Male	575-120	1+	£3.22	50+	£2.85
Black Female	577-770	1+	£3.41	50+	£2.96

Neutrik NC3FD-S-1-B/NC3MD-S-1-B

XLR Screw Chassis Connector

3 pole receptacle chassis connector.

- Robust "D" metal shell
- Standardized D sized 24 mm panel cutout
- Screw terminals



Description	Code	Price (Ex VAT)			
3 Pin Silver Female	511-180	1+	£2.79	10+	£2.39
3 Pin Silver Male	511-190	1+	£4.81	10+	£4.11

Neutrik Combi XLR/Jack

A 3 pole latching XLR socket and a 1/4" Jack socket.

- Switch material 0.2µ, Hardgold, contact material 2µ Silver plated
- Solder buckets
- Switching contacts for every situation including XLR earth lift or not
- Compatible with existing combo



Description	Code	Price (Ex VAT)			
3 Pin Combi Female	578-550	1+	£2.59	10+	£2.30

CONNECTORS

Neutrik XLR Accessories

Neutrik XLR Dummy Plugs

Covers unused inputs to avoid miswiring/plugging and protect against dust and dirt.

- Dummy plug
- Colour Black



Description	Code	Price (Ex VAT)			
Female NDF	581-910	1+	£0.47	10+	£0.39
Male NDM	581-920	1+	£0.47	10+	£0.39

Neutrik SCCD-W

Spring-Loaded Cover

Shuts automatically after unplugging the cable connector and seals the chassis connectors against dust and water to IP65.

- Suitable for XLR D Series, speakON NL2M and NL4M, powerCON 20 A Series, opticalCON Chassis Connectors, USB NAUSB-W, HDMI NAHDMI-W, Firewire NAT394-6-W, etherCON D Series, etherCON CAT6 Chassis Connectors, BNC D Series Phono, (RCA) Chassis Connectors



NEW

Description	Code	Price (Ex VAT)			
SCCD-W	511-790	1+	£10.50	20+	£9.40

XLR Plates

DBA-BL Blanking Plate

- Blanks off XLR cut out
- Colour Black



SCM Splash Proof Dust Covers

- For Neutrik NC3FD (Male) chassis XLRs

Description	Code	Price (Ex VAT)			
DBA-BL	578-120	1+	£0.69	50+	£0.59
SCM	581-310	1+	£0.55	50+	£0.48

Neutrik SCD-W

D-Type Sealing Cap

Universal sealing cap for male and female D-sized chassis connectors.

- Great for dusty and dirty environments
- XLR mounting screws pass through the sealing caps base.



Description	Code	Price (Ex VAT)			
SCD-W	511-660	1+	£0.99	10+	£0.89

Neutrik SCDX D Type

Connector Cover

Neutrik SCDX D type cut out Cover IP54 protection against dust and splash water.

- For all D-size receptacles Snap fit
- Lettering space



Neutrik SCDR D Type

Rear End Cover

Soft plastic cover for the rear end of several D-size chassis connectors.

- It is used to protect gap between connector and cable



Description	Code	Price (Ex VAT)			
SCDX	581-970	1+	£0.72	10+	£0.63
SCDR	511-000	1+	£1.23	20+	£1.08

Neutrik MFD

D Type Mounting Plate

Saves rummaging round for lost nuts!

- Fixing plate with M3 thread
- Offers efficient and easy mounting of all D-sized chassis connectors by M3 screws



Description	Code	Price (Ex VAT)			
Mounting Plate	581-980	1+	£0.30	20+	£0.26

CONNECTORS

Bantam/TT Plugs

Neutrik Bantam

Hard Gold and Nickel for normal operation.

- Available in two finishes
- Both have either Black or Red handles
- 4.6mm diameter cable such as Klotz Code 544-580 or Sommer Code 546-040



Description	Code	Price (Ex VAT)			
Gold/Black	578-610	1+	£4.84	10+	£4.24
Gold/Red	578-620	1+	£4.84	10+	£4.24
Nickel Black	578-000	1+	£3.81	10+	£3.32
Nickel Red	578-600	1+	£3.81	10+	£3.32

1000s of products Available from stock!

MORE PRODUCTS online

FOR fax orders Use our fax number... 020 8450 4390

CONNECTORS

Tiny QG XLR (Mini)

Switchcraft Tini QG

Mini XLR

A highly reliable product from the No 1 manufacturer.

- 3 and 4 pin male and female versions for cable mounting
- Lifetime guarantee



Description	Code	Price (Ex VAT)			
Tini QG 3 pin male	578-690	1+	£4.69	5+	£4.11
Tini QG 3 pin female	578-700	1+	£5.69	5+	£4.97
Tini QG 4 pin male	578-710	1+	£7.46	5+	£6.52
Tini QG 4 pin female	578-720	1+	£7.24	5+	£6.34

REAN (Neutrik) Tini XLR

RTFC-B 3-4-5 Pin Female

- TINY XLR female cable connector, black metal shell, gold plated contacts



RTMC-B 3-4-5 PIN Male

- TINY XLR cable connector, black metal shell, gold plated contacts



RTFCT-B 3-4-5 Pin Locking

- TINY XLR cable connector with screw locking, black metal shell and nut, gold plated contacts



Description	Code	Price (Ex VAT)			
RT3FC-B 3 Pin Female	511-220	1+	£1.51	10+	£1.32
RT4FC-B 4 Pin Female	511-230	1+	£1.79	10+	£1.49
RT5FC-B 5 Pin Female	511-240	1+	£2.06	10+	£1.75
RT3MC-B 3 Pole Male	511-510	1+	£1.24	50+	£1.12
RT4MC-B 4 Pole Male	511-520	1+	£1.48	50+	£1.34
RT5MC-B 5 Pole Male	511-530	1+	£1.68	50+	£1.52
RT3FCT-B Locking 3 Pole	511-480	1+	£2.04	50+	£1.84
RT4FCT-B Locking 4 Pole	511-490	1+	£2.30	50+	£2.07
RT5FCT-B Locking 5 Pole	511-500	1+	£2.50	50+	£2.25

CONNECTORS

Jack Plugs

REAN (Neutrik) NYS225

Speaker Jack Plug

Specifically designed for high currents.

- 8mm cable entry and a strain relief



Description	Code	Price (Ex VAT)			
NYS225	578-030	1+	£1.17	50+	£1.01

Metal Bodied Line Socket

Can be wired mono/stereo, balanced/unbalanced.

- Including strain relief
- Cables up to 6mm diameter



Description	Code	Price (Ex VAT)			
Type A	575-100	1+	£1.22	10+	£1.06

Studiospares Jack Plugs

Mono/Stereo

Classic lines and good quality.

Hard chrome on nickel for extended life. Split chuck for cables 3.8mm to 7mm. Rubbery plastic strain relief. Tags take solder like a dream. Mono and stereo. Lifetime guarantee.

Made to the ISO9001 standard.

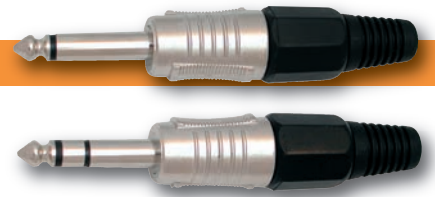

Description	Code	Price (Ex VAT)			
Mono	568-400	1+	£0.69	50+	£0.56
Stereo	568-410	1+	£0.79	50+	£0.64

Neutrik NJ3FP6C Locking Jack Socket

D type cut out for chassis mounting.

- Substantial construction
- This lockable version can be wired for stereo/mono balanced/unbalanced operation



Description	Code	Price (Ex VAT)			
NJ3FP6C	575-991	1+	£4.61	50+	£3.91

Locking Chassis Jack Socket

D type cut out.

- Plug cannot be withdrawn until Red release button is depressed
- Stereo/mono balanced/unbalanced
- Manufacturer works to ISO9001 standard



Description	Code	Price (Ex VAT)			
Chassis Jack Socket	568-040	1+	£1.75	50+	£1.55

Studiospares All Metal Jacks

10 Pack

A high quality product.

All metal construction. Hard chrome finish. Good crimp type cable retention. Knurled barrel for positive grip. Solder flows easily. Maximum cable diameter 6.3 mm.

Made to ISO9001 standard.

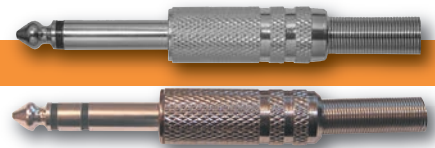

Description	Code	Price (Ex VAT)			
Mono - 10 Pack	575-330	1+	£6.94	10+	£6.34
Stereo - 10 Pack	575-000	1+	£5.85	5+	£5.11

MORE PRODUCTS online

DELIVERY BEFORE NOON no problem

Neutrik NP2X/NP3X

Jack Plugs

Highest quality and extremely popular.

Sturdy construction. Cable secured by collet assembly. Rubber seal strain relief.

Accepts cable diameters from 4.0 to 7mm.

Description	Code	Price (Ex VAT)					
NP2X Unbalanced Silver	575-500	1+	£2.46	50+	£2.17	100+	£1.85
NP2X-WT Unbalanced White	575-505	1+	£3.26	50+	£2.62	100+	£2.34
NP2X Unbalanced Black	575-130	1+	£2.47	50+	£2.16	100+	£1.86
NP3X Balanced Silver	575-890	1+	£3.48	50+	£3.07	100+	£2.60
NP3X Balanced Black	575-860	1+	£3.49	50+	£3.08	100+	£2.60

Neutrik NP2/3X-B

Intended for any application where zero contact resistance is essential. Tribor Gold plated (a very hard alloy).

Description	Code	Price (Ex VAT)					
NP2X-B	581-420	1+	£2.99	50+	£2.64	100+	£2.23
NP3X-B	511-270	1+	£4.22	50+	£3.59	100+	£3.06



Precision Plus Jack Plug

Includes 6 coloured rings to provide quick plug identification. A precision product designed to last a lifetime. Modern design.



- Attractive matt chrome finish.
- Gold plated tip for enhanced reliability
- Secure cable clamping system
- Strain relief spring spreads troublesome bending load over a large area greatly increasing reliability.
- Solders like a dream.



Description	Code	Price (Ex VAT)			
Mono Jack	568-740	1+	£1.45	50+	£1.27
Mono Stereo	568-750	1+	£1.55	50+	£1.36
Spare 6 colours ring set	568-770	1+	£0.25	50+	£0.20

Studiospares Heavy Duty Jacks

A really thick machined and knurled barrel with a sprung strain relief.

- Excellent cable retention
- Moulded on plastic grip won't slip
- Chrome Heavy Duty contacts which will last a lifetime
- Lifetime guarantee
- Maximum cable dia 6.7mm
- Made to the ISO9001 standard



Description	Code	Price (Ex VAT)			
Mono	568-070	1+	£0.56	50+	£0.48
Stereo	568-080	1+	£0.68	50+	£0.57

Neutrik NP2RX-AU

Silent Jack

THE ultimate Gold bodied silent Jack.

- Contains a reed switch which shorts live to earth until fully inserted
- Saves blowing speakers (and ears)



Description	Code	Price (Ex VAT)			
NP2RX-AU R/A version	581-590	1+	£7.22	10+	£6.33
NP2C-AU Single version	581-540	1+	£6.56	10+	£5.97

Right Angled Mono Jack

Heavy duty, all metal right angled 6.3mm Jack plug.

- For cables up to 8mm
- Good cable grip and reliable contact material



Description	Code	Price (Ex VAT)			
Monojack Silver	596-920	1+	£1.26	5+	£1.15
Monojack Red	596-930	1+	£1.26	5+	£1.15
Monojack Black	596-940	1+	£1.26	5+	£1.15

Neutrik Right Angled Slim Jacks

Mono/Stereo

Slim right angled Jack plugs.

NP2RX mono and NP3RX stereo. All metal design. Accepts cable diameters 3mm to 7mm. The suffix

- **BAG** denotes Black chrome finish nickel contacts
- **B** denotes Black Chrome finish + Gold contacts

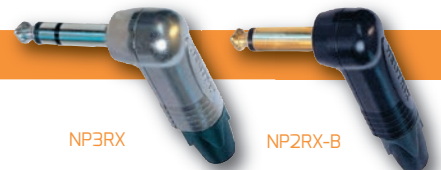

Description	Code	Price (Ex VAT)					
NP2RX Mono	578-010	1+	£2.73	10+	£2.40	25+	£2.05
NP3RX Stereo	578-020	1+	£4.73	10+	£4.16	25+	£3.55
NP3RX-BAG Mono	581-610	1+	£2.78	10+	£2.45	25+	£2.08
NP3RX-BAG Stereo	581-730	1+	£4.76	10+	£4.19	50+	£3.57
NP2RX-B Mono	581-600	1+	£3.12	10+	£2.75	25+	£2.35
NP3RX-B Stereo	581-740	1+	£5.18	10+	£4.55	50+	£3.88

SATURDAY DELIVERY
no problem

ALL PRICES EXCLUSIVE OF VAT.

CONNECTORS

Jack Plugs

CONTINUED

Neutrik NPX Series

Coloured Boots and Rings

For outdoor use.

- Order Boots using 578-08x
- The last digit determines the colour. eg a blue boot order 578-086



Neutrik Coloured Rings

The NC-XX series has optional coloured rings.

- Order using 578-09x
- The last digit determines the colour. eg a red ring, order 578-092



Brown = 1, red = 2, orange = 3, yellow = 4, green = 5, blue = 6, violet = 7, grey = 8, white = 9.

Description	Code	Price (Ex VAT)
BPX Boots	578-08x	1+ £0.50 10+ £0.44
PXR Rings	578-09x	1+ £0.22 10+ £0.18
Rings Bag of 6 Colours	568-770	1+ £0.25 50+ £0.20

Switchcraft Jack Plugs

Heavy Duty Nickel plated brass construction.

- Heavy gauge cable crimp
- Easily soldered
- 7mm cable entry
- America's best
- Lifetime guarantee
- Switchcraft reliability



Description	Code	Price (Ex VAT)
Mono Jack Plug	575-510	1+ £1.99 50+ £1.74
Stereo Jack Plug	578-730	1+ £2.35 50+ £2.08

REAN (Neutrik) NYS2245 Silent Jack

Mutes signal when withdrawn.

- No ear splitting rasps when gear is replugged
- Plug shorts tip to ground



Description	Code	Price (Ex VAT)
NYS2245	581-400	1+ £1.17 10+ £1.01

Neutrik NP2XL

Speaker Jack Plug

2 pole 1/4" professional phone plug, up to 10 mm cable O.D

- High current capacity
- Neutrik guaranteed quality



Description	Code	Price (Ex VAT)
NP2XL	511-250	1+ £4.55 50+ £3.96

Neutrik Jack Dummy Plug

Plugs into the hole in the socket.

- NDJ for 1/4" Jacks



Description	Code	Price (Ex VAT)
Jack Dummy Plug	581-950	1+ £0.47 10+ £0.39

1000s
of products
Available from stock!

CONNECTORS

Jacks Type B/Post Office 316

Neutrik B Type NP3TB Post Office

Jack plug with a chuck type strain relief.

- Jack plug with a chuck type strain relief
- All metal design
- Black nickel finish
- Compatible with BPO 316



Description	Code	Price (Ex VAT)
NP3TB HL	577-350	1+ £4.44 10+ £3.88

CONNECTORS

Mini Jacks

Minijack Socket Wide Barrel

3.5mm Jack socket with shielded body and soft plastic cover with cable protector.

- For cables up to 5mm.



Description	Code	Price (Ex VAT)
Stereo	596-990	1+ £0.88 5+ £0.79

REAN (Neutrik) NYS226

Mono Mini Jack Plug

Mono version.

- Nickel on Brass 4mm cable entry



Description	Code	Price (Ex VAT)
NYS226	511-280	1+ £0.76 10+ £0.68

Switchcraft 35HDLNPKG

Mini Jack Plug

3.5mm Locking Mini Jack Plug and Socket.

- A quality product with a M6 x 0.5 locking thread and a 6.35mm cable entry

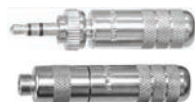

Description	Code	Price (Ex VAT)
Mini Jack Plug	578-470	1+ £8.42 10+ £7.67
Mini Jack Socket	578-480	1+ £7.18 10+ £6.34

REAN (Neutrik) Mini Jack Plug

Gold plated contacts.

- Screw on barrel finished in Black
- Positive cable clamp
- Reliability comes as standard



Description	Code	Price (Ex VAT)
Minijack Gold	578-810	1+ £1.25 20+ £1.10

REAN (Neutrik) NYS231

Mini Jack

Nickel/Gold plated body on diecast zinc with good cable retention and the capacity to accept 8mm/6mm cables.

- NYS231LL - Nickel plated, 8mm wide
- NYS231LBG - Gold plated, 6mm wide



Description	Code	Price (Ex VAT)
NYS231LL 8mm wide	511-640	1+ £1.24 10+ £1.12
NYS231LBG 6mm wide	511-650	1+ £1.12 10+ £1.01

Neutrik NTP3RC

Right Angled Mini Jack Plug

A Mini Jack plug with a proper chuck style cable retention system.

- OK for cable diameters 2.0mm to 4.5mm
- Prolongs socket life as it reduces side pull
- Balanced/unbalanced



Description	Code	Price (Ex VAT)
NTP3RC Black	581-430	1+ £3.30 10+ £2.90
NTP3RC Nickel	581-410	1+ £2.59 10+ £2.27

REAN (Neutrik) 3.5mm Jack Plug

3 pole so can be wired mono/stereo, unbalanced or balanced.

- Proven reliability



Description	Code	Price (Ex VAT)
Mono/Stereo	575-920	1+ £0.75 10+ £0.65

CONNECTORS

BNC Plugs

BNC Plugs

High quality finish with a Gold pin.

- 50 ohms for RG58/URM-43,76
- 75 ohms for RG59BU, URM-70, 62a



Description	Code	Price (Ex VAT)
BNC Plug 50Ω	575-470	1+ £1.65 10+ £1.40
BNC Plug 75Ω	575-650	1+ £0.98 10+ £0.88

Neutrik NBNC75BFG7/NBNC75BLP7

BNC Rear Twist

BNC Cable Connectors

- NBNC75BFG7 - Argosy Image 360, Belden 1855ENH, Bryant BD 5001, Canford SDV-S-LFH, Canford SDV, Canford SDM, Cordial CVI 06-28, Cordial CVI 3-7, Draka 0.6/2.8 AF, Draka 0.6 L/2.8 AF, Fuzion SD-1, Sommer 600-0101M, Sommer 600-0104M, Klotz V06/28, VMXX75Y, Nexans HF 75 0.6/2.9 02Y5(ST)CH
- NBNC75BLP7 - Belden 8241, CAE KXGA, Canare LV-615, Cordial CVI (CVM) 06-37, Draka 0.6/3.7, Draka 0.6L/3.7, Proel HPC 805, RG59B/U, Sommer 600-0051 (M,L,S), Sommer 600-0054 (M,L,S), Klotz V06/37.



Description	Code	Price (Ex VAT)
NBNC75BFG7	581-490	1+ £2.02 10+ £1.82
NBNC75BLP7	578-570	1+ £1.99 10+ £1.79

THE website

Keep up to date with all the latest products and current prices on the Studiospares website!

check out www.studiospares.com

CONNECTORS

MIDI/DIN

MIDI/DIN Plug

Substantial all metal construction.

- Fully screened
- Crimp cable clamp
- Rubber strain relief with seal
- Proven reliability
- Maximum cable diameter 7mm



Description	Code	Price (Ex VAT)
MIDI 5pin DIN	575-841	1+ £0.99 10+ £0.88

MIDI/DIN 5 Pin Back/Back

Back to Back Coupler

Good quality for long life.

- Joins two 5 pin MIDI/DIN leads.
- Female connector each end



Description	Code	Price (Ex VAT)
5 Pin Back/Back	578-110	1+ £1.96 10+ £1.78

Neutrik NYS321G Gold/Silver

3 Pin Din

3 pole all metal DIN connector.

- Gold/Silver plated contacts
- Turned brass shell



Description	Code	Price (Ex VAT)
NYS321G Gold	511-540	1+ £1.08 50+ £0.96
NYS321S Silver	511-550	1+ £1.08 50+ £0.96

REAN (Neutrik) MIDI Connectors

5 Pin MIDI Connectors.

- NYS322. 5 pole MIDI/DIN cable connector, silver plated contacts
- NYS322G. 5 pole MIDI/DIN cable connector, gold plated contacts
- NYS321G 3 pole MIDI/DIN cable connector, gold plated contacts
- NYS325 5 pole MIDI/DIN chassis connector, silver plated contacts



Description	Code	Price (Ex VAT)
NYS322	511-300	1+ £0.97 50+ £0.87
NYS322G	511-310	1+ £0.99 50+ £0.89
NYS321G	511-540	1+ £1.08 50+ £0.96
NYS325	511-320	1+ £0.64 50+ £0.58

CONNECTORS

Phono (RCA)

REAN (Neutrik) NYS373

Phono Plug

Gold contacts.

- Earth connection is sprung to grip property
- Small and large (both supplied) spring strain reliefs cover cables 3 - 6.1mm
- Chuck cable grip



Description	Code	Price (Ex VAT)
NYS373 Black	581-440	1+ £1.14 10+ £1.00
NYS373 Red	581-442	1+ £1.14 10+ £1.00
NYS373 Yellow	581-444	1+ £1.14 10+ £1.00
NYS373 Green	581-445	1+ £1.14 10+ £1.00
NYS373 Blue	581-446	1+ £1.14 10+ £1.00

Phono Plug

Precision Engineered

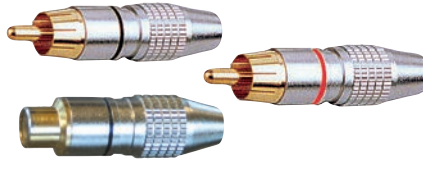

Solidly engineered, this precision component incl. an eight part sprung collar. Contact and soldering lug surfaces Gold plated. Cable clamped by a toothed crimp. Gold contacts and a chrome body. Lifetime guarantee. Manufactured to the ISO9001 standard. Maximum cable diameter 5.7mm.

Description	Code	Price (Ex VAT)
Male Black	568-130	1+ £0.61 10+ £0.56
Male Red	568-640	1+ £0.58 10+ £0.53
Female Black	568-150	1+ £0.59 10+ £0.54
Female Black	568-650	1+ £0.59 10+ £0.54

Phono Plug

Sold Singly

Good crimp style toothed cable clamp spreads the load.

- 3 part sprung earthing collar
- Matte chrome finish
- Manufactured to ISO9001 standard
- Maximum cable diameter 6.8mm



Description	Code	Price (Ex VAT)
Phono Plug	568-140	1+ £0.58 10+ £0.53

Neutrik Profi NF2C-B-2

Gold Plated Phono Plug

Professional Machined brass construction.

- Ground before signal connection
- Quick assembly
- Chuck cable retention
- Cable 3mm to 7.3mm
- Sold as a Red and Black pair



Description	Code	Price (Ex VAT)
NF2C-B-2 x2	578-800	1+ £14.14 5+ £12.46

Neutrik Phono

An easy solution to mounting a Phono socket in a D type cut out.

- Earth isolated from chassis



Description	Code	Price (Ex VAT)
Black Shell	581-450	1+ £3.41 10+ £3.07
Nickel Shell	581-460	1+ £3.41 10+ £3.07

CONNECTORS

Speaker Plugs

Neutrik NL2FX

Speakon Plug

Fits 2 and 4 pin sockets.

- 2 pole connector
- Chuck type strain relief
- Intermates with 4-pole chassis connector
- Makes contact with +1/-1
- Easy and extremely precise locking system "Quick Lock"



Description	Code	Price (Ex VAT)
NL2FX	578-170	1+ £2.63 10+ £2.31

Neutrik NP2XL

Speaker Jack Plug

High current 2 pole speaker jack.

- OK for cables up to 10mm diameter
- Robust diecast shell in stylish design
- Proven chuck type strain relief for reliable cable retention



Description	Code	Price (Ex VAT)
NP2XL	511-250	1+ £4.55 50+ £3.96

Neutrik NLT8FX/MX

8-Pole Speakon

Rugged 8-pole female cable connector.

- Current 40 A continuous, 50 A audio with 50% duty cycle
- Extra large solder contacts for up to 6mm² (AWG10) wires
- Mate with all available speakON products



Description	Code	Price (Ex VAT)
Fem NLT8FX	511-340	1+ £15.99 10+ £13.97
Fem NLT8FX-BAG Black	511-350	1+ £16.82 10+ £14.74
Male NLT8MX Black	511-390	1+ £19.96 10+ £17.92

Neutrik 4 Pole Speakon

4 PIN Loudspeaker Plug

- Cost reduced 4 pole version mates with existing NL4MP, pins +1 and -1 contacts
- Shorter external body retains all Speakon features



Description	Code	Price (Ex VAT)
NL4FC	511-330	1+ £4.64 10+ £4.16

Neutrik R/Angled SPX Speakon

1pc strain relief, OK for cables OD 6-14mm.

- 50 amp (over 1000 watts)
- Convert to a straight plug by removing LRX part



Description	Code	Price (Ex VAT)
R/Angled Speakon	581-120	1+ £5.27 50+ £4.63

REAN (Neutrik) NYS225

Speaker Jack Plug

Specifically designed for high currents.

- 8.5mm cable entry and a strain relief.



Description	Code	Price (Ex VAT)
NYS225	578-030	1+ £1.17 50+ £1.01

PRICE changes

This catalogue was priced on 1st December 2014.

Current prices may be higher...

see our website for up to date prices.

CONNECTORS

Speaker Plugs

CONTINUED

Neutrik 4/8 Pole Speakon

Speaker Plugs



The industry-standard for loudspeaker connections.



NL4FX

Suits cable dia 6mm - 14mm. Can be converted to right angle with LRX.

NL8FC

Suits cable dia 8mm - 20mm. Silver contacts rated at 30 mps.

Description	Code	Price (Ex VAT)					
NL4FX	575-260	1+	£3.98	10+	£3.49	25+	£2.98
NL8FC	575-420	1+	£9.97	10+	£8.71	25+	£7.51

Speakloc Chassis Socket

4/8 Pin Loudspeaker Sockets

High current capability with very low contact resistance.

- Absolute reliability
- Lifetime guarantee



Description	Code	Price (Ex VAT)			
Chassis 4-Pole	568-680	1+	£2.28	10+	£2.05
Chassis 8-Pole	568-690	1+	£4.82	10+	£4.34

Neutrik Speakon Accessories

Cover and Dummy Plug

The handy dust protection cover can be used, when no cable connector is mated.

- SCL and Dummy Plug



Description	Code	Price (Ex VAT)			
Speaker Cover	581-580	1+	£1.33	10+	£1.17
Dummy Plug	581-930	1+	£0.47	10+	£0.39

Speakloc 4/8 Pole

4/8 Pole Plugs and Sockets

Totally dependable.

Mates with any twist-to-lock speaker socket.

Lifetime guarantee.



Description	Code	Price (Ex VAT)					
Speakloc 4 pin plug	568-660	1+	£1.84	10+	£1.66	25+	£1.48
Speakloc 8 pin plug	568-670	1+	£4.24	10+	£3.82	25+	£3.40
Speakloc 4 pin chassis socket	568-680	1+	£2.28	10+	£2.05	25+	£1.82
Speakloc 8 pin chassis socket	568-690	1+	£4.82	10+	£4.34	25+	£3.86

Neutrik Speakon Chassis

Speakon Chassis

An airtight 4pin chassis cut out same as D type connector.

- New 8 pin type
- Circular flange 5cm diameter with 4 fixing holes and metal front plate



Description	Code	Price (Ex VAT)			
NL4MP	575-040	1+	£1.78	10+	£1.68
NL4MP-ST Screw-on	511-560	1+	£3.20	25+	£2.87
NL8MPR	577-340	1+	£6.32	10+	£5.91
NL8MPR-BAG Black	511-380	1+	£7.18	10+	£6.28

Banana Jack

High quality Gold plugs with color

- Screw fixing



Description	Code	Price (Ex VAT)			
Banana Red	597-180	1+	£0.88	5+	£0.79
Banana Black	597-190	1+	£0.88	5+	£0.79

Neutrik Speakon STX

Touring Line

Metal housing.

- Includes weatherproof sealing rings (to IP34), 50 amp rated (50% duty cycle) 4 pole.



Description	Code	Price (Ex VAT)			
Male NLT4MX Silver	581-140	1+	£7.94	50+	£6.95
Female NLT4FX Silver	581-150	1+	£7.78	50+	£6.83
Male NLT4MX Black	581-160	1+	£7.94	50+	£6.95
Female NLT4FX Black	581-170	1+	£8.28	50+	£7.24

- 4 pole Black chrome female chassis connector
- For harsh and weatherproof applications
- All metal housing and a built-in gasket providing weatherproof protection to IP54



Description	Code	Price (Ex VAT)			
NLT4MP-BAG Male	581-210	1+	£5.11	50+	£4.44
NLT4FP-BAG Female	581-200	1+	£7.08	50+	£6.19

Gold Plated 4mm Stackable

Identified with Red and Black bands.

- Four banana plugs with a screw clamping action on wire up to 5.5mm diameter.
- Packed 2 pairs per pack.



Description	Code	Price (Ex VAT)			
Speaker Plugs x4	578-510	1+	£9.92	5+	£9.36

CONNECTORS

Ethernet

Neutrik RJ-45

Ethernet Connector

A Neutrik die cast shell which cradles any popular RJ-45 connector.

- The shell is locking, will protect the Ethernet connector from damage
- Locks onto the cable using the well-proven chuck principle



Chassis Receptacles

Chassis receptacles mount to any chassis. Compatible with the Neutrik D type footprint.

NE8FDV-YK

- D series shell, IDC/Krone terminations



NE8FDP

- Chassis connector with a D type housing
- Back to back feedthrough



NE8FF

- RJ45 feedthrough coupler for cable extensions
- Accommodates NE8MC* or any standard RJ45 plug
- Approved latch lock system



Description	Code	Price (Ex VAT)			
NE8MC	578-840	1+	£2.18	10+	£1.93
NE8FDV-YK	581-320	1+	£7.25	10+	£6.37
NE8FDP	581-330	1+	£7.47	10+	£6.53
NE8FF	511-630	1+	£12.67	10+	£11.40

DELIVERY BEFORE NOON
no problem

SATURDAY DELIVERY
no problem

CONNECTORS

Feed Through Chassis Connectors

Neutrik NADB9MF/NADB15MF

DSUB Feedthrough

Male to female feedthrough in 9 and 15 pin configuration.

- Sub miniature connectors which are widely used as video display ports or serial communication



Description	Code	Price (Ex VAT)		
NADB9MF 9 Pin	511-720	1+	£10.66	10+ £9.06
NADB15MF 15 Pin	511-730	1+	£17.90	10+ £15.22

Neutrik NO2-4FDW-A

Opticalcon Chassis

Four solder contacts and 1 LC-Duplex feedthrough socket.

- Designed as feedthrough with automatic sealing shutter
- Accommodates standard LC connectors on the rear for simple installation
- Connection on the front side either by rugged opticalCON or standard LC connector



Description	Code	Price (Ex VAT)		
NO2-4FDW-A	511-710	1+	£48.15	2+ £45.80

Switchcraft EH35MMS

3.5mm Chassis Socket

As used for portable electronic connections and headphone sockets.

- Solder tags at rear
- Nickel finish only



Description	Code	Price (Ex VAT)		
EH35MMS	563-000	1+	£9.75	5+ £8.88

Switchcraft EHBNCRCA

Feedthrough BNC - PHONO RCA

BNC on the front panel and Phono on the rear.

- Nickel finish only in UK
- Panel Coupler in an XLR Shell



Description	Code	Price (Ex VAT)		
BNCRCA	563-050	1+	£6.38	5+ £5.74

Switchcraft EHRCABNC

Feedthrough Phono RCA - BNC

RCA Phono on the front and a BNC on the rear.

- Nickel finish only
- Designed to last a lifetime



Description	Code	Price (Ex VAT)		
RCABNC	563-060	1+	£6.42	5+ £5.86

Switchcraft EH DB9MF

Feedthrough 9 pin D SUB Ma - Fe

9 pin D sub male one side and 9 pin D sub female the other side.

- Male - Female reversible



Switchcraft EH DB9FF

Feedthrough 9 pin D SUB Fe - Fe

- 9 pin D Sub female both sides



Description	Code	Price (Ex VAT)		
DB9MF	563-070	1+	£7.72	5+ £6.94
DB9FF	563-080	1+	£7.72	5+ £6.94

Neutrik NAHDMI-W

HDMI Feedthrough Adaptor

HDMI 1.3 feedthrough adaptor.

- D-shape housing



Description	Code	Price (Ex VAT)		
NAHDMI-W	511-010	1+	£8.67	10+ £7.63

Neutrik NBB75DSI

Feedthrough BNC D Type Chassis

BNC socket mounted in a D type cut out.

- True 75Ω design
- OK for HDTV/DVD requirements
- Insulated from ground



Description	Code	Price (Ex VAT)		
NBB75DSI	581-480	1+	£6.68	10+ £6.08

Switchcraft EH HD15MF

Feedthrough 15 pin D Sub Ma-Fe

15 pin HD D Sub Male to 15 pin HD D Sub Female.

- 9 pin version shown and in reverse



Description	Code	Price (Ex VAT)		
EH HD15MF	563-090	1+	£8.72	5+ £7.83

Switchcraft EH 15FF

Feedthrough 15 pin D Sub Fe-Fe

15 pin HD D Sub Female to 15 pin HD D Sub Female.

- 9 pin version shown



Description	Code	Price (Ex VAT)		
EH 15FF	563-100	1+	£8.72	5+ £7.83

Switchcraft EHHDMI2

HDMI Feedthrough

From one of the world most respected manufacturers.

- Contacts brass with gold on nickel
- D type cut out.



Description	Code	Price (Ex VAT)		
EHHDMI2	563-110	1+	£9.90	5+ £8.95

Neutrik Feedthrough Firewire

Firewire 6 with IEEE 1394 6-pol receptacles on both ends.

- Nickel D-housing



Neutrik Feedthrough USB

Reversible USB genderchanger (type A and B).

- Nickel D-housing



Description	Code	Price (Ex VAT)		
NA1394-6	581-500	1+	£6.38	10+ £5.44
NA1394-6 Black	581-501	1+	£6.64	10+ £5.85
NAUSB	581-510	1+	£4.38	10+ £3.82
NAUSB Black	581-511	1+	£4.81	10+ £4.28

Neutrik NA3FDM/MDF

3-Pole Feedthrough

XLR feedthrough adapter for panel mount

- 55mm depth behind the panel
- Diecast shell with Nickel plating
- Mate with all available speakON products



Description	Code	Price (Ex VAT)		
NA3FDM Female-Male	511-200	1+	£5.52	10+ £4.97
NA3MDF Male-Female	511-210	1+	£4.42	10+ £3.78

Neutrik NBB75DFI

Feedthrough BNC

BNC coupler feeds through a D type cut out.

- OK for HDTV/DVD requirements
- Insulated from ground



Description	Code	Price (Ex VAT)		
NBB75DFI	581-470	1+	£6.08	10+ £5.32

CONNECTORS

DMX Adaptors

Switchcraft DMX Adaptors

Chassis receptacles mount to any chassis. Compatible with the Neutrik D type footprint.

- S3F5M 3 pin female to 5 pin male (pins)
- S5F3M 5 pin female to 3 pin male (pins)



Description	Code	Price (Ex VAT)		
S3F5M 3 Pin Fe - 5 Pin Ma	578-820	1+	£12.85	10+ £10.95
S3F5M 5 Pin Fe - 3 Pin Ma	578-830	1+	£12.85	10+ £10.95

Studiospares DMX Adaptors

- DMX Adaptor 3 pin female to 5 pin male. Lifetime guarantee.
- DMX Adaptor 5 pin female to 3 pin male. Lifetime guarantee.



Description	Code	Price (Ex VAT)		
DMX 3 Pin Fe - 5 Pin Ma	568-460	1+	£6.75	5+ £6.05
DMX 5 Pin Fe - 3 Pin Ma	568-450	1+	£6.75	5+ £6.05

MORE PRODUCTS
online

DELIVERY BEFORE 10AM
no problem

DELIVERY BEFORE NOON
no problem

ALL PRICES EXCLUSIVE OF VAT.

CONNECTORS

XLR Sex Changers

Studiospares Back-Back Adaptors

Sex Changers

Enables two XLR males or females to be joined.

XLR Female to XLR Female Adaptor

XLR female to XLR female adaptor. Enables two XLR males to be joined. Lifetime guarantee.

XLR Male to XLR Male Adaptor

XLR male to XLR male adaptor. Enables two XLR females to be joined. Lifetime guarantee.

Description	Code	Price (Ex VAT)					
Female to Female	568-440	1+	£4.08	5+	£3.67	10+	£3.26
Male to Male	568-430	1+	£3.78	5+	£3.29	10+	£2.84

Neutrik NA3MM**Back - Back XLR Male**

Back to Back XLR sex changer.

- 3 Pin

Description	Code	Price (Ex VAT)					
NA3MM	581-080	1+	£7.22	5+	£6.34		

Neutrik NA3FF**Back - Back XLR Female**

Back to Back XLR sex changer.

- 3 Pin

Description	Code	Price (Ex VAT)					
NA3FF	581-040	1+	£7.62	5+	£6.67		

CONNECTORS

XLR Phase Reversers

Studiospares Phase Reverser

XLR male to XLR female adaptor.

- Reverses phase by swapping pins 2-3 and 3-2
- Lifetime guarantee

Description	Code	Price (Ex VAT)					
Phase Reverser	568-420	1+	£3.60	5+	£3.15		

Neutrik NA3FMX**Phase Reversal Adaptor**

3 pole XLR female - 3 pole XLR male.

- Contacts 2 - 3 inverted

Description	Code	Price (Ex VAT)					
NA3FMX	581-090	1+	£7.58	5+	£6.68		

CONNECTORS

XLR Earth Lift Adaptor

Hosa Ground Lift**Adaptor**

An XLR male to XLR female adaptor.

- Can eliminate ground loops without tears

Description	Code	Price (Ex VAT)					
Ground Lift Adaptor	578-780	1+	£7.82	10+	£6.76		

CONNECTORS

XLR - Jack Adaptors

3 Pin XLR Male - Jack Plug**By Studiospares**

3 pin XLR male to Jack plug.

- Wired pin 2 hot
- Balanced/unbalanced stereo/mono
- Lifetime guarantee

Description	Code	Price (Ex VAT)					
XLR Male - Jack Plug	568-510	1+	£5.90	5+	£5.40		

3 Pin XLR Female - Jack Plug**By Studiospares**

3 pin XLR female to Jack plug.

- Unbalanced and balanced versions.
- A must have for sound engineers
- Lifetime guarantee

Description	Code	Price (Ex VAT)					
XLR Fe-Jack balanced	568-520	1+	£3.78	5+	£3.39		
XLR Fe-Jack unbalanced	568-780	1+	£3.60	5+	£3.30		

Neutrik NA2MP**XLR Male - Monojack Plug**

3 pole XLR male - Mono 1/4" plug.

- Tip, Sleeve contact

Description	Code	Price (Ex VAT)					
NA2MP	511-070	1+	£8.36	5+	£7.44		

Neutrik NA2FP**XLR Female - Monojack Plug**

3 pole XLR female - Mono 1/4" plug.

- Tip, Sleeve contact

Description	Code	Price (Ex VAT)					
NA2FP	511-060	1+	£8.10	5+	£7.16		

Neutrik NA3MP**XLR Male - Jack Plug**

Stereo adaptor.

- Grounding pin 3 on the XLR or the ring on the Jack will unbalance the adaptor

Description	Code	Price (Ex VAT)					
NA3MP	575-161	1+	£9.58	5+	£8.44		

Neutrik NA3FP**XLR Female - Jack Plug**

Stereo adaptor.

- Grounding pin 3 on the XLR or the ring on the Jack will unbalance the adaptor.

Description	Code	Price (Ex VAT)					
NA3FP	581-020	1+	£9.58	5+	£8.39		

3 Pin XLR Male - Locking Jack Socket**By Studiospares**

3 pin XLR male to Jack socket.

- Stops the plug being accidentally withdrawn
- Wired pin 2 hot
- Balanced/stereo
- Lifetime guarantee

Description	Code	Price (Ex VAT)					
XLR Ma - Jack Socket	568-490	1+	£4.20	5+	£3.86		

3 Pin XLR Female - Locking Jack Socket**By Studiospares**

Adaptor 3 pin XLR female to Jack socket.

- Stops the plug being accidentally withdrawn
- Wired pin 2 hot
- Balanced/stereo

Description	Code	Price (Ex VAT)					
XLR Fe - Jack Socket	568-500	1+	£4.20	5+	£3.86		

Neutrik NA2F-J-TX**Jack - XLR Male Unbalanced/Balanced Converter**

For unbalanced to balanced line conversion where no earth or gain switching is required.

- Audio transformer 1:1
- Rugged aluminium extrusion housing

Description	Code	Price (Ex VAT)					
XLR Male - Jack Socket	581-570	1+	£24.19	5+	£21.28		

MORE PRODUCTS
online

1000s
of products
Available from stock!

3 Pin XLR Female - Jack Socket

By Studiospares

3 pin XLR female to Jack socket.

- Wired pin 2 hot
- Balanced/stereo
- Lifetime guarantee



Description	Code	Price (Ex VAT)			
XLR Fem - Jack Socket	568-470	1+	£3.78	5+	£3.29

3 Pin XLR Male - Jack Socket

By Studiospares

3 pin XLR male to Jack socket.

- Wired pin 2 hot
- Balanced/stereo
- Lifetime guarantee



Description	Code	Price (Ex VAT)			
XLR Male - Jack Socket	568-480	1+	£3.60	5+	£3.15

Neutrik NA3FJ

Locking Adaptor XLR - Jack Socket

XLR female to balanced Jack socket.

- The Jack plug is locked in place and released by depressing the red tab



Description	Code	Price (Ex VAT)			
NA3FJ	581-010	1+	£10.81	5+	£9.44

XLR Male - Mono Jack Socket

By Studiospares

1 x XLR Male plug to 1 x 6.35mm standard mono Jack socket.



Description	Code	Price (Ex VAT)			
XLR Male - Mono Jack	595-110	1+	£4.87	3+	£4.32

Neutrik NA3MJ

XLR Male - Balanced Jack Socket

XLR male to balanced Jack socket.

- The Jack plug is locked in place and released by depressing the red tab



Description	Code	Price (Ex VAT)			
NA3MJ	581-050	1+	£10.62	5+	£9.33

CONNECTORS

XLR - Phono Adaptors

XLR Male - Phono Socket

By Studiospares

XLR male to Phono socket.

- Mono/unbalanced
- Lifetime guarantee



Description	Code	Price (Ex VAT)			
XLR Male - Phono Skt	568-560	1+	£3.60	5+	£3.15

Neutrik NA2MPMF

XLR Male - Phono Socket

Wired pin 2 hot.

- Chrome finish



Description	Code	Price (Ex VAT)			
NA2MPMF	581-060	1+	£8.49	5+	£7.44

XLR Female - Phono Plug

By Studiospares

XLR female to Phono plug.

- Mono/unbalanced
- Lifetime guarantee



Description	Code	Price (Ex VAT)			
XLR Fem - Phono Plug	568-530	1+	£3.60	5+	£3.15

XLR Male - Phono Plug

By Studiospares

XLR male to Phono plug.

- Mono/unbalanced
- Lifetime guarantee



Description	Code	Price (Ex VAT)			
XLR Male - Phono Plug	568-540	1+	£3.60	5+	£3.15

XLR Female - Phono Socket

By Studiospares

XLR Female to Phono socket.

- Mono/unbalanced
- Lifetime guarantee



Description	Code	Price (Ex VAT)			
XLR Fem - Phono Skt	568-550	1+	£3.60	5+	£3.15

Neutrik NA2FPMP

XLR Female - Phono Socket

XLR female to a Phono socket.

- Wired pin 2 hot
- Chrome finish



Description	Code	Price (Ex VAT)			
NA2FPMP	581-030	1+	£8.34	5+	£7.30

Neutrik NA2MPMM

XLR Male - Phono Plug

Wired pin 2 hot.

- Chrome finish



Description	Code	Price (Ex VAT)			
NA2MPMM	581-070	1+	£9.16	5+	£7.91

Neutrik NA2M-DOB-TX/NA2F-DOB-TX

XLR - Phono Adaptor

Miniature line level transformer balancing adapter 3 pole XLR - Phono socket.

- Audio transformer 1:1
- Rugged aluminium extrusion housing



Description	Code	Price (Ex VAT)			
NA2M-DOB-TX Male	581-750	1+	£23.40	5+	£20.94
NA2MF-DOB-TX Fem	581-760	1+	£23.90	5+	£21.42

XLR - BNC Adaptors

Neutrik NA2FBNC

XLR Female - BNC Socket

XLR female to BNC socket.



Description	Code	Price (Ex VAT)			
NA2FBNC	581-360	1+	£9.40	10+	£8.22

Neutrik NA2MBNC

XLR Male - BNC Socket

XLR Male to BNC socket.



Description	Code	Price (Ex VAT)			
NA2MBNC	581-370	1+	£9.22	10+	£8.12

CONNECTORS

Jack + Phono Adaptors

Monojack - Phono Socket

Gold Adaptor

Gold plated Jack to Phono adaptor.

- Guarantees perfect contact every time



Description	Code	Price (Ex VAT)			
MonoJack - Phono Skt	568-700	1+	£1.25	10+	£1.13

Hosa GPP-151 90°

Right Angle Adaptor

Mono Right Angle Jack Plug to Jack Socket adaptor.

- Enables an existing Jack plug to be inserted at 90° to the socket
- Chrome finish



Description	Code	Price (Ex VAT)			
GPP-151	578-270	1+	£3.38	5+	£3.11

Stereo Jack Plug - Mono Jack Socket

By Studiospares

Stereo Jack Plug to Mono Jack socket.

- Combines stereo to mono
- Used at the mixers insert point to provide a direct output



Description	Code	Price (Ex VAT)			
GPP-419	595-400	1+	£2.58	10+	£2.32

Hosa GPM-179

Mono Jack Plug - Mini Jack Socket

Mono Jack plug to 3.5mm Stereo Mini Jack socket.



Description	Code	Price (Ex VAT)			
GPM-179	595-380	1+	£2.58	10+	£2.32

Stereo Jack Socket - Stereo Jack Socket Adaptor

Adaptor

Stereo Jack socket to Stereo Jack socket.

- Joins two Jack plug leads together



Description	Code	Price (Ex VAT)			
St Jack Skt - St Jack Skt	595-090	1+	£2.48	3+	£2.17

VISIT
our trade counter
You'll get friendly advice and immediate access to 8000+ product lines!

CONNECTORS

Jack + Phono Connectors

CONTINUED

Jack to Phono Adaptors

Popular range of adaptors.

Jack Plug to Phono Socket

Mono Jack plug to Phono socket adaptor.

Stereo Jack to Mini Jack Socket

Quarter inch stereo Jack plug to 3.5mm stereo mini Jack socket. If either plug or socket is mono, adaptor will become mono.

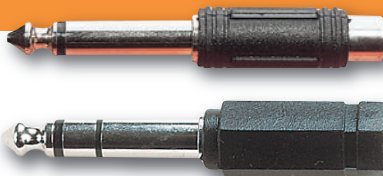

Description	Code	Price (Ex VAT)					
Jack Plug to Phono Socket	575-270	1+	£0.99	10+	£0.89	25+	£0.79
Stereo Jack to Mini Jack Socket	575-170	1+	£0.99	10+	£0.89	25+	£0.79

Dual Phono Socket - Phono Socket

By Studiospa

Dual coupler with two Phono sockets each end.

- Back to back



Description	Code	Price (Ex VAT)			
Dual Phono Coupler	568-190	1+	£1.96	10+	£1.76

Phono Socket - Phono Socket

By Studiospares

Phono socket to Phono socket.

- Firm grip (Back to back)



Description	Code	Price (Ex VAT)			
Phono Skt - Phono Skt	575-900	1+	£0.59	10+	£0.53

Jack Plug - Phono Socket

Right Angle

Mono Jack plug to Phono socket at 90°.

- Pack of 2



Description	Code	Price (Ex VAT)			
Jack Plug - Phono Skt	578-280	1+	£2.98	5+	£2.66

Jack Plug - Jack Plug

By Studiospares

Quarter inch mono Jack plug to quarter inch Jack plug (Back to back).

- Quality nickel plated on copper contact
- Very solid construction



Description	Code	Price (Ex VAT)			
NYS237	578-050	1+	£1.14	50+	£1.00

Hosa GPP-273

Stereo Jack Plug - Jack Socket

Stereo Jack plug to Stereo Jack socket.

- Converts a straight plug to a right angle.



Description	Code	Price (Ex VAT)			
GPP-273	595-430	1+	£4.16	10+	£3.79

REAN (Neutrik) NYS236

Mono Jack Back to Back

Quarter inch mono Jack socket to quarter inch Jack socket.

- Very solid construction



Description	Code	Price (Ex VAT)			
NYS236	578-040	1+	£1.26	50+	£1.11

Phono Plug - Mono Jack Socket

Adaptor

Mono Phono plug to mono Jack socket.



Description	Code	Price (Ex VAT)			
Phono - MonoJk Skt	575-280	1+	£0.99	10+	£0.89

3.5mm Mono - Phono Socket

Adaptor

Converts a 3.5mm Mini Jack plug to Phono socket.

- Mono



Description	Code	Price (Ex VAT)			
MiniJk Plug - Phono Skt	568-170	1+	£1.64	10+	£1.44

Right Angle Phono Adaptor

By Studiospares

Right angled Phono adaptor.

- Saves space and downward exertion on equipment socket



Description	Code	Price (Ex VAT)			
R/Angeled Phono adaptor	578-390	1+	£1.78	5+	£1.58

WANT a job?

Are you looking for a stable and rewarding career?

Studiospares are constantly expanding. We require additional staff for a variety of positions, working in a very congenial atmosphere. Practical experience of recording and/or live sound engineering would be preferable.

send in your CV in the first instance

CONNECTORS

Minijack + Phono Adaptors

Minijack Socket - Minijack Socket

By Studiospares

3.5mm Minijack socket to 3.5mm Minijack socket adaptor.

- Stereo



Description	Code	Price (Ex VAT)			
Mini Jack - Mini Jack	595-100	1+	£2.57	3+	£2.27

Hosa GMP-386

Minijack Plug - Mono Jack Socket

Mini Jack stereo plug to Mono Jack socket.

- Combines stereo to mono



Description	Code	Price (Ex VAT)			
GMP-386	595-390	1+	£2.09	10+	£1.91

Mini Jack Mono/Stereo Adaptor

Interface plugs for changing between standard Jack and Mini Jacks.

- Good quality components and build
- Good for use with headphone, mic and line level interconnections.



Description	Code	Price (Ex VAT)			
1/8" Mono - 1/8" Stereo	597-570	1+	£3.40	10+	£3.06
1/8" Mono - 1/4" Stereo	597-580	1+	£3.40	10+	£3.06

Locking Mini Jack - Microjack Socket

By Hosa

3.5mm stereo Mini Jack plug to 2.5mm stereo Micro Jack socket.



Description	Code	Price (Ex VAT)			
Mini Jk - Micro Jk Skt	595-680	1+	£11.96	5+	£10.82

Screw-in 1/8" Minijack - 1/4" Jack Adaptor

Converts a screw in Mini Jack plug to standard quarter inch plug.

- Gold plated for best contact
- Stereo throughout



Description	Code	Price (Ex VAT)			
1/8" Minijack-1/4" Jack	448-768	1+	£2.25	10+	£2.02

2.5mm - 3.5mm Right Angle Adaptor

By Hosa

2.5mm Micro Jack plug to 3.5mm Mini Jack socket.



Description	Code	Price (Ex VAT)			
Micro Jk - Mini Jk Plug	596-430	1+	£1.98	10+	£1.79

Mini Jack Socket - 2x Phono Sockets

By Hosa

3.5mm stereo Mini Jack socket to two Phono sockets.



Description	Code	Price (Ex VAT)			
Mini Jk - 2x Phono Skt	595-410	1+	£2.88	10+	£2.61

Mini Jack - Stereo Jack Socket

Hosa

3.5mm stereo Mini Jack plug to quarter inch stereo Jack socket.



If either the mating plug and/or socket is mono, adaptor will then automatically become mono.

Description	Code	Price (Ex VAT)			
Mini Jack - Stereo Jack Socket	575-450	1+	£0.99	10+	£0.83

2.5mm Micro Jack - 3.5mm Socket

By Hosa

2.5mm Mini Jack plug to 3.5mm Mini Jack socket.



Description	Code	Price (Ex VAT)			
Micro Jack - Socket	582-470	1+	£2.12	10+	£1.84

Hosa GMP-272

Mini Jack Right Angle Converter

3.5mm Stereo Mini Jack plug to 3.5mm Stereo Mini Jack socket.



- Converts a straight plug to a right angle
- A great space saver

Description	Code	Price (Ex VAT)			
GMP-272	595-420	1+	£2.49	10+	£2.25

2.5mm - 3.5mm Adaptor

2.5mm Micro Jack socket to 3.5mm Mini Jack plug.



Description	Code	Price (Ex VAT)			
Microk Skt - Miniuk Plug	596-440	1+	£1.95	10+	£1.76

Mini XLR Adaptors

Rode VXL

XLR Male - Mini XLR

The VXL is used to convert a 3.5mm mini-jack to a 3 pin XLR

- All metal construction
- 58.00mmH x 19.00mmW x 19.00mmD
- A useful accessory for the tool box



Description	Code	Price (Ex VAT)			
VXL	417-950	1+	£8.58	10+	£7.72

XLR Male - Mini XLR Socket

Enables a 3pin Mini XLR plug to be connected into a standard female XLR input socket.



Description	Code	Price (Ex VAT)			
EMA-300P	255-830	1+	£22.60	2+	£21.40

Switchcraft 318

Mini Jack - Male XLR

Any Mini Jack input to Male XLR output. With volume control.

- Ground lift switch
- Stereo input Mono XLR output
- Bomb proof Switchcraft build quality



Description	Code	Price (Ex VAT)			
318	403-380	1+	£62.50	10+	£57.90

BNC - Phono Adaptors

BNC - Phono Adaptor

By Studiospares

Audio/Video adaptor.

- Useful accessory to keep in the tool kit.



Description	Code	Price (Ex VAT)			
BNC - Phono Adaptor	575-430	1+	£1.84	10+	£1.64

Video Adaptors

VGA Female To DVI-I Male

Video Adaptor

VGA female - DVI-I male.



Description	Code	Price (Ex VAT)			
VGA Fem - DVI-I Male	596-510	1+	£6.40	5+	£6.20

SVGA to HDMI Converter

Allows you to connect computers or other sources with DVI output and R/L to an HDMI display.

- Supports R/L input
- Install in seconds, no need of setting



Description	Code	Price (Ex VAT)			
SVGA - HDMI	603-040	1+	£37.50	2+	£34.50

3x Phono - 3x Phono

A/V Adaptor

For Audio Left, Right and Video signals.



Description	Code	Price (Ex VAT)			
3 x Phono - 3 x Phono	597-490	1+	£1.82	10+	£1.64

HDMI Audio Extractor

Extracts audio signals from an HDMI source and converts it to Digital Toslink or analogue audio.

- Compliant with HDMI 1.3, HDCP 1.2 and DVI 1.0; Supports HDMI Sample Rates up to 192 kHz



Description	Code	Price (Ex VAT)			
HDMI Audio Extractor	603-060	1+	£45.00	2+	£41.60

CONNECTORS

Speakon Adaptors

Neutrik Speakon Adaptors

These interface various connectors with the Speakon line.



Size	Description	Code
NA4FC-M	NL4FC to male XLR plug	581-230
NA4FC-F	NL4FC to female XLR plug	581-240
NA4MP-M	NL4MP to male XLR plug	581-250
NA4MP-F	NL4MP to female XLR plug	581-260
NA4MP-M-X	Phase inverter NL4MP to NL4MP	581-770
NA4MP-J	NL4MP to locking Jack socket	581-270

Description	Code	Price (Ex VAT)			
NA4FC-M	581-230	1+	£11.04	5+	£9.64
NA4FC-F	581-240	1+	£12.48	5+	£10.97
NA4MP-M	581-250	1+	£11.80	5+	£10.38
NA4MP-F	581-260	1+	£12.18	5+	£10.67
NA4MP-M-X	581-770	1+	£10.99	10+	£9.67
NA4MP-J	581-270	1+	£11.98	5+	£10.46

Neutrik 4 Pin Speakon Adaptor

1/4 Inch Jack Adaptor

Plug in a quarter inch Jack to a Speakon output.

- An essential piece of kit for anyone involved in PA.



Description	Code	Price (Ex VAT)			
Speakon Adaptor	578-790	1+	£6.62	5+	£5.76

Neutrik NL4MMX

Inline Speakon Coupler



For extension leads.

Couples two Speakon line plugs together. 4pin.

Description	Code	Price (Ex VAT)			
NL4MMX	575-910	1+	£4.36	10+	£3.81

Neutrik 8 Pin Speakon Coupler

Lockable Speakon Coupler

Couples two 8 pin Speakon line plugs together.

- For extension leads



Description	Code	Price (Ex VAT)			
NL8MM	581-520	1+	£11.62	5+	£10.91

MORE PRODUCTS online

CONNECTORS

Signal Splitters

Stereo Mini Jack - 2x Phono Sockets

By Studiospares

3.5mm Stereo Mini Jack plug to two Phono sockets.



Description	Code	Price (Ex VAT)		
St Minijk - 2x Phono Skts	578-760	1+	£2.28	5+ £1.98

Mini Jack - 2x 3.5mm Mini Jack Sockets

By Studiospares

3.5mm Mini stereo Jack plug to two stereo 3.5mm Mini Jack sockets.



Description	Code	Price (Ex VAT)		
Minijk - 2x Minijk Skts	578-740	1+	£2.67	5+ £2.28

Back - Back MIDI Sockets (DIN)

By Studiospares

Two 5 pin MIDI sockets back to back.



Description	Code	Price (Ex VAT)		
Back-Back MIDI Skts	578-110	1+	£1.96	10+ £1.78

Phono Socket - 2x Phono Sockets

Y Splitter

Phono (RCA) socket to 2 x Phono (RCA) sockets.



Description	Code	Price (Ex VAT)		
Phono Splitter	597-100	1+	£1.91	5+ £1.72

Stereo Jack - 2x Stereo Jack Sockets

Y Splitter

Stereo Jack plug to two stereo Jack sockets.



- Can also be used as mono (Y splitter)
- Frequently used as a Headphone Splitter

Description	Code	Price (Ex VAT)		
Y Splitter	575-180	1+	£1.63	10+ £1.48

Mono Jack - 2x Phono Sockets

Y Splitter

6.3mm Mono Jack plug to 2 x Phono (RCA) sockets.



- Y splitter/adaptor

Description	Code	Price (Ex VAT)		
Monojk - 2x Phono Skts	597-040	1+	£1.71	5+ £1.53

Mono Jack - 2x Mono Jack Sockets

Y Splitter

6.3mm Mono Jack plug to 2 x 6.3mm Mono Jack sockets.



Description	Code	Price (Ex VAT)		
Monojk - 2x Monojk Skts	597-050	1+	£1.49	5+ £1.35

Stereo Jack - 2x Phono Splitter

Splitter

Connects tip of stereo Jack to Phono socket A, and ring to Phono socket B.



- For insert sockets send and return connections

Description	Code	Price (Ex VAT)		
St Jk - 2 Phono Splitter	577-810	1+	£1.56	5+ £1.38

Stereo Jack - 2x Mini Jack Sockets

Splitter

Stereo Jack plug to two stereo 3.5mm Mini Jack sockets.



Description	Code	Price (Ex VAT)		
BCK HA2	578-750	1+	£2.16	5+ £1.92

Phono Y Splitter

Splitter

Phono plug to two Phono sockets (Y splitter).



Description	Code	Price (Ex VAT)		
Phono Y Splitter	575-440	1+	£1.53	10+ £1.39

Mini Jack - 2x Mini Jack Sockets Gold

Y Splitter

3.5mm stereo Jack plug to 2 x 3.5mm stereo Jack sockets.



- Gold connectors

Description	Code	Price (Ex VAT)		
Minijk Splitter	597-060	1+	£2.56	5+ £2.31

Mini Jack - 2x Phono Sockets Gold

Y Splitter

3.5mm stereo Jack plug to 2 x RCA Phono sockets.



- Gold plated

Description	Code	Price (Ex VAT)		
Minijk - 2 Phono Skts	597-070	1+	£2.59	5+ £2.34

Digital Audio Converter AUD-3



Converts Digital to Analogue signals.

- Coaxial or Toslink digital audio signals to analogue L/R audio
- Supports sampling rate at 32,44,1,48 and 96kHz
- 24-bit S/PDIF incoming bit stream on left and right channels



Description	Code	Price (Ex VAT)		
Digital Audio Converter	603-050	1+	£32.50	2+ £29.50

Neutrik Digital Audio Adaptors



Matches 110Ω (AES/EBU) to 75Ω circuits via a transformer. Allows longer cable runs via unbalanced coaxial lines rather than twisted pair cables that present high attenuation values at the relevant frequencies. Two versions.

Size	Description	Code
NADITBNC-F	110Ω Female XLR input to 75Ω BNC output	578-300
NADITBNC-M	75Ω BNC input to 110Ω XLR male output. Max voltage 5v p-p in the band 0.1MHz to 15MHz.	578-310

Description	Code	Price (Ex VAT)		
NADITBNC-F	578-300	1+	£29.90	3+ £27.90
NADITBNC-M	578-310	1+	£29.90	3+ £27.90

CONNECTORS

Optical Adaptors + Couplers

Studiospares RED507

Optical Converter SPDIF To AES/EBU



The RED507 allowing simultaneous transfer of two channels of digital audio in either format in either direction. It converts between AES/EBU (XLR) and SPDIF (TOSlink fibre optic). Transfers are made without leaving the digital domain. 24-bit/96kHz. Power supply included.

Description	Code	Price (Ex VAT)		
RED507	465-760	1+	£49.50	2+ £47.50

UPM25

Coupler

A panel mounted back to back coupler for connecting together two Toslink type optical cables.



- Neutrik D type panel cut out

Description	Code	Price (Ex VAT)		
UPM25	900-022	1+	£7.47	3+ £6.92

See online for more optical adaptors.

Audio Adaptors

Studiospares RED508

Signal Routing Box



A really useful switcher box that can be used two ways. To direct a signal from one source, say a guitar/keyboard to either an amplifier or to the house PA system. In reverse the SW-21 can direct any one of two signals like bass or acoustic guitars to one amplifier. The possible combinations are endless. A link switch links both inputs or outputs together so that a guitar can be connected to both an amplifier AND the in house PA system.

Description	Code	Price (Ex VAT)		
RED508	465-770	1+	£20.82	2+ £18.90

Toslink Splitter

For the audio signal distribution from one digital optical input to two outputs, using Toslink cables.

- Supports S/PDIF standard of digital audio transmission, uncompressed 2-channel LPCM and compressed 2-channel and multi-channel Dolby and DTS audio
- Input port 1 x Toslink (Optical Fiber)
- Output ports 2 x Toslink (Optical Fiber), Power Supply 5V/1A DC



NEW

Description	Code	Price (Ex VAT)
Toslink Splitter	603-070	1+ £24.99 10+ £23.99

CONNECTORS

Audio Transformers

Neutrik NTE-1

Audio Transformer

Professional audio transformer 1:1 with free wires.

- Applications: general purpose, splitting and XLR inline
- Source/load impedance 200/2k Ω, (600/10k Ω)

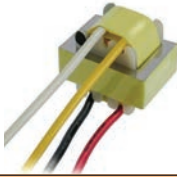

Description	Code	Price (Ex VAT)
NTE-1	511-400	1+ £8.84 10+ £7.95

CONNECTORS

Impedance Converters

Impedance Converter

Matches low impedance microphones to any high impedance input.

- 200Ω to 600Ω input impedance
- 20kΩ output impedance
- Output unbalanced
- Allows a low impedance mic to be plugged into a guitar input.



Description	Code	Price (Ex VAT)
Impedance Converter	568-710	1+ £12.20 2+ £10.70

CONNECTORS

IEC Mains Components

IEC Extension Lead

6 Amp

High quality IEC extension cable.

- 1 x IEC Male to 1 x IEC female output
- Strong cable clamp
- High quality cable
- Max load: 6A
- Lengths: 2m, 5m and 10m



NEW

Description	Code	Price (Ex VAT)
2m White	756-000	1+ £4.61 10+ £4.18
5m White	756-010	1+ £6.81 10+ £6.13
5m Black	756-020	1+ £6.81 10+ £6.13
10m White	756-030	1+ £11.00 10+ £9.90
10m Black	756-040	1+ £11.00 10+ £9.90

IEC Extension/Jumper Lead

1m/2m

Male shrouded IEC plug.

Fitted to 6 amp cable with a 10 amp IEC socket for equipment powering.



Description	Code	Price (Ex VAT)
IEC Extension 1m	574-320	1+ £3.97 10+ £3.61 25+ £3.24
IEC Extension 2m	574-360	1+ £4.61 10+ £4.18 25+ £3.71

Neutrik powerCON TRUE1

The powerCON TRUE1 replaces appliance couplers wherever a very rugged solution in combination with a locking device is needed in order to guarantee a safe power connection.

- Locking 16/20 A true mains connector
- Can be connected/disconnected when plugged in without burning the contacts
- Easy and reliable twist lock system
- IP65 – water resistant when mated with ready-made cord sets



Neutrik powerCON

Designed to bridge the gap between low current domestic connectors and 3 phase power plugs.

- Meets all existing IEC power regulations
- Blue for an inlet, grey for outlet
- When mated colours MUST BE THE SAME
- 20 Amp capacity with a resistive load



Size	Description	Code
NAC 3MX	Male connector, power-out, screw terminals	511-420
NAC 3FX	Female connector, power-out, screw terminals	511-430
NAC 3MPX	Appliance inlet connector, 1/4" flat tab terminals	511-440
NAC 3FPX	Appliance outlet connector, 1/4" flat tab terminals	511-450
NAC 3PX	Inlet-Outlet combination, 1/4" flat tab terminals	511-460
NAC 3FXW	Locking female cable connector, power-in, screw terminals, 2m	511-670
NAC 3FXW	Locking female cable connector, power-in, screw terminals, 5m	511-680

Description	Code	Price (Ex VAT)
NAC 3MX	511-420	1+ £5.43 10+ £4.88
NAC 3FX	511-430	1+ £5.43 10+ £4.88
NAC 3MPX	511-440	1+ £2.57 10+ £2.31
NAC 3FPX	511-450	1+ £4.62 10+ £4.16
NAC 3PX	511-460	1+ £6.28 10+ £5.65
NAC 3FXW 2m	511-670	1+ £11.80 5+ £10.60
NAC 3FXW 5m	511-680	1+ £19.95 5+ £18.35
Extension Lead 0.5m	511-690	1+ £11.80 5+ £10.60
Extension Lead 1.5m	511-700	1+ £15.20 5+ £13.60

Size	Description	Code
NAC 3FCA	Mains cable connector Power Input, 20 amp	577-150
NAC3FC-HC	Mains cable connector Power Input, 30 amp	581-820
NAC 3FCB	Same cable connector but for Power Output	577-380
NAC 3MPA	Chassis mounted Power Input	577-390
NAC3MP-HC	Chassis mounted Power Input 32 amps	581-830
NAC 3MPB	Chassis mounted Power Output	577-960
NAC 3MM	Coupler for linking cable connectors	577-970

Description	Code	Price (Ex VAT)
NAC 3FCA	577-150	1+ £4.61 10+ £4.05
NAC 3FC-HC	581-820	1+ £12.18 10+ £10.78
NAC 3FCB	577-380	1+ £4.61 10+ £4.05
NAC 3MPA	577-390	1+ £2.33 10+ £2.03
NAC3MP-HC	581-830	1+ £7.28 10+ £6.39
NAC 3MPB	577-960	1+ £2.33 5+ £2.03
NAC 3MM	577-970	1+ £13.73 10+ £12.08

CONNECTORS

Mains Components

2 Gang 30m Extension Reeler

This is a 2 Gang 30m Extension Drum.

- Supplied with a stand, carry handle and reset button
- 5A maximum current when fully wound
- 13A max current when fully unwound



Description	Code	Price (Ex VAT)
2 Gang 30m	538-580	1+ £24.40 2+ £21.90

1 Gang Extension With 5m Lead

This is a black 1 Gang 5m Extension Lead.

- Supplied in a hanging bag and is fitted with a 13A plug and fused at 5 amps



Description	Code	Price (Ex VAT)
1 Gang 5m	538-550	1+ £6.42 5+ £5.78

VISIT
our trade counter
You'll get friendly advice and immediate access to 8000+ product lines!

MORE PRODUCTS online

CONNECTORS

Mains Components

CONTINUED

Moulded Mains Leads UK EU USA



UK 13Amp 3Pin 2m Long
13amp mains plug fused at 5amps fitted with 2 metres of 6amp cable with a 10Amp IEC socket **574-270**

UK 13Amp 3Pin 3m Long
13amp fused plug fitted to 3 metres of 10amp cable with a 10amp IEC socket **574-000**

European Plug To IEC 2m Long
Angled Schuko plug fitted to 2 metres of 6Amp cable with a 10amp IEC socket **574-340**

American To IEC 2m Long
3 pin US plug fitted to 2 metres of 18AWG (6amp) cable, with a 10amp IEC socket. **573-560**

IEC Extension/'Jumper' Lead
Male shrouded IEC plug fitted to 6 amp cable with a 10 amp IEC socket. 1m and 2m **574-320**
574-360

Description	Code	Price (Ex VAT)		
IEC 3 Pin-13A 2m	574-270	1+	£5.19	10+ £4.40
IEC 3 Pin-13A 3m	574-000	1+	£5.76	10+ £5.04
European IEC Lead 6A	574-340	1+	£6.90	10+ £5.98
American Mains Lead	573-560	1+	£3.90	10+ £3.40
IEC Extension Lead 1m	574-320	1+	£3.97	10+ £3.61
IEC Extension Lead 2m	574-360	1+	£4.61	10+ £4.18

White 2 Gang Extension

With Neon And Lead

This is a White 2 Gang Extension with Neon and Lead and it is fitted with a 13A plug.

- This 2m extension is supplied in a hanging bag
- Both extension sockets are fused at 13 amps
- Available in 2m and 10m



Description	Code	Price (Ex VAT)		
2m	538-560	1+	£4.95	5+ £4.45
10m	538-570	1+	£8.80	5+ £7.77

4Way Outlet Socket



A good quality product which includes two LEDs, one for Mains Present, the other for Fuse Blown.

- Includes two keyhole style slots for wall mounting
- Pitch between socket centres 55mm
- Fused at 13amps
- Manufactured to British Standards BS1363/A
- Overall diameter 6.35mm

Complete Trailing Lead



A decent quality product that includes an LED to confirm Mains On.

- Pitch between socket centres 55mm
- Four shuttered sockets and a 13a fuse
- Includes two metres of cable and a fused 13A plug
- Manufactured to British Standards BS1363/A

Description	Code	Price (Ex VAT)		
4way 13A Socket	535-080	1+	£4.97	5+ £4.12
4way Trailing Lead	535-070	1+	£6.22	5+ £5.57

Fig 8 Lead

Popular on some synths and low power electronic equipment.

- Small "Fig of 8" moulded mains input lead with 13 amp plug.



Description	Code	Price (Ex VAT)		
Fig 8 Lead 1.8m	580-380	1+	£4.46	3+ £3.94

13 Amp Mains Plugs

- A. 13amp mains plug. Meets current UK legislation BSI 1363
- B. Decent contact that resist corrosion and which are sleeved for safety



Description	Code	Price (Ex VAT)		
13a Plug	575-871	1+	£0.64	5+ £0.59

Extension Reel

4-Way

Includes friction free technology, better stability and heat dispersion for the best power solution available.

- Cable does not easily kink.
- Total power capacity 2.5kW when unwound
- 4 socket with thermal cut-out.
- Friction free and easy to wind.



Description	Code	Price (Ex VAT)		
10m 10A	538-600	1+	£16.66	2+ £15.80
8m 13A	538-610	1+	£16.66	2+ £15.80
25m 13A	538-620	1+	£27.50	2+ £25.30

RCD Safety Cut Out

Trips and removes the supply voltage immediately it senses current flowing from the live conductor to earth.

- Made in the event of anyone touching the live conductor as a current would flow through the person to ground
- Includes a test button which simulates a fault condition
- Maximum load 3000 watts, 13amps
- Not a substitute for vigilance and sensible precautions



Description	Code	Price (Ex VAT)		
Safety Cut Out	450-170	1+	£19.60	2+ £18.20

Black Outlet Socket

With Trailing Lead

A 4 way mains extension socket with neon indicator and fixing holes for wall mounting.

- The Cable is 5 metres of 3 x 1.25mm² tamperproof
- Conforms to BS1363/A
- Voltage - 250Vac
- Dimensions mm - 251 x 59 x 26



Description	Code	Price (Ex VAT)		
Outlet Socket	475-940	1+	£7.22	5+ £6.67

European To UK Plug Converter

Converts 2 - pin CEE7 Euro plug to UK mains plug.

- Conforms to BS5733, fused at 5A
- Europlug slides in and cover closes clamping the plug in place



Description	Code	Price (Ex VAT)		
Plug Converter	401-310	1+	£1.64	10+ £1.44

Ceeform Connectors



Description	Code	Price (Ex VAT)		
16amp 2P+T IP44 flying plug (with pins)	437-380	1+	£4.75	10+ £3.99
16amp 2P+T IP44 flying socket	437-390	1+	£6.25	10+ £5.45
32amp 2P+T IP44 flying plug (with pins)	437-400	1+	£7.25	10+ £6.65
32amp 2P+T IP44 flying socket	437-410	1+	£12.80	10+ £11.60

Description	Code	Price (Ex VAT)		
16A Plug	437-380	1+	£4.75	10+ £3.99
16A Socket	437-390	1+	£6.25	10+ £5.45
32A Plug	437-400	1+	£7.25	10+ £6.65
32A Socket	437-410	1+	£12.80	10+ £11.60

Double and Treble Cordset

UK and European

Provide an ideal solution to the problem of mains cabling surrounding the rear of most equipment and computer installations.

- Quality European manufacturer
- BS 1363A plug directly moulded, not ultrasonically welded.
- Meets ASTA specifications.
- Heavy duty cabling



Double UK 13amp

The 13 amp plug is moulded to a harmonised PVC 3 core cable of 1mm cross sectional area. 2 metres from the plug is a Y junction splitting the power to two 0.5m cables with straight type IEC 320 connectors. Length 2.5m. Colour Black.

Treble UK version

Includes two Y junctions from where the cable splits. Powers a total of three IEC 320 connectors. Overall length 2.5m. Colour Black.

Description	Code	Price (Ex VAT)		
Double UK 13 Amp	574-410	1+	£15.66	5+ £14.94
Treble UK Version	574-450	1+	£13.22	5+ £11.86

PRICE match
Studiospares will BEAT any genuine price from any UK competitor on any item or order.
details on page 318

1000s of products
Available from stock!

DELIVERY BEFORE 10AM no problem

CONNECTORS

Mains Filtering

Mains PDU Rackmounted Surge Protector

19" 6 Way Mains PDU



Tough 6 way outlet with fixing lugs each end to fit into a rack.

1U 6 way Horizontal 13A switched PDU with Surge protection for any 19" rack system. The inclusion Metal Oxide Semiconductor surge protection components is a sensible way to ensure unwanted spikes do not corrupt CPUs or generate clicks in audio equipment. Absorbs a maximum surge of 4500 Amps. Status LED confirms protection is ON. A Delta network gives protection against RFI going in or out of the sockets. New slimline 1U High Density design (bear in mind UK plugs are over 1U high) features Earth-Stud to attach your equipment. Lead length 2 metres. Colour Black.

Description	Code	Price (Ex VAT)
6-Way 2m	517-300	1+ £24.50 5+ £22.80

Surge Protected Outlets

4/10 Way

Suitable for protection of computers and other sensitive electronic devices from voltage spikes and surges.

- 2-sided 10-way outlet, having 5 outlets on each side
- Features a neon on indicator
- Vertical base stand for ease of use
- Colour White



Description	Code	Price (Ex VAT)
4-Way Outlet	538-380	1+ £9.90 2+ £8.90
10-Way Outlet	538-390	1+ £19.30 2+ £17.80

Ferrite Clamps

RFI Interference Suppression

Designed to reduce electromagnetic interference being induced or radiated from cables.

- Clamps onto cables
- Place at the equipment end of cable
- OK for signal and mains cables
- Really effective against taxis



Description	Code	Price (Ex VAT)
For cables up to 10mm	537-940	1+ £1.98 10+ £1.78
For cables up to 13mm	537-950	1+ £2.34 10+ £2.11

Ultimate Trailing Mains Conditioner 2m

6 Way



The ultimate trailing outlet with additional Earth Line filtering to arrest interference coming in via the earth line.

- Even the mains input cable is shielded!
- Surge protection extends to 6500 Amps
- Delta network gives protection against RFI going in/out of the sockets
- Includes Metal Oxide Semiconductor surge protection components
- Surge status LED indicates Surge protection ON
- Cable length 2 metres

Description	Code	Price (Ex VAT)
Conditioner 6-Way 2m	517-330	1+ £25.30 5+ £23.90

4 Way Surge Protected Extension Block

Features adjustable rear screws to allow the unit to sit flush to the wall.

- A 4 Way Surge Protected Extension Block



Description	Code	Price (Ex VAT)
4 Way Surge	538-590	1+ £9.75 5+ £8.75

Enhanced AV Surge Protector 2m

6 Way



Enables you to keep some equipment in standby mode and others switched off.

- Provides the ability to switch off selected sockets
- The inclusion Metal Oxide Semiconductor surge protection components is a sensible way to ensure unwanted spikes do not corrupt CPUs or generate clicks in audio equipment
- Absorbs a maximum surge of 4500 Amps
- Surge status LED indicates Surge protection ON
- Cable length 2 metres

Description	Code	Price (Ex VAT)
Switched 6-Way 2m	517-340	1+ £12.75 5+ £11.86

13 Amp 6 Way Surge Outlet



This 13amp 6 way surge protected socket strip includes a neon light which indicates protection is OK.

- A severe surge will cause the light to extinguish but will not interrupt the power allowing the unit to function without protection
- Surge protection 4500 amps per three elements
- Supplied with 2m of mains cable with a moulded 13amp mains plug

Description	Code	Price (Ex VAT)
6 Way Surge	538-290	1+ £12.40 2+ £11.20

Switched Surge Protector Outlet Strip

6 Way



Enables you to keep some equipment in standby mode and others switched off.

- Provides the ability to switch off selected sockets
- The Metal Oxide Semiconductor surge protection components is a sensible way to ensure unwanted spikes do not corrupt CPUs or generate clicks in audio equipment
- Absorbs a maximum surge of 4500 Amps
- Surge status LED indicates Surge protection ON
- Cable length 2 metres

Description	Code	Price (Ex VAT)
Switched 6-Way 2m	517-350	1+ £14.79 5+ £13.96

Vertical Rackmounting Mains PDU

8/12 Way



For mounting vertically inside a rack.

- Robust construction with mounting lugs either end
- One of the few products to meet the more stringent B51362/2 standard

Description	Code	Price (Ex VAT)
8-Way	517-310	1+ £27.40 5+ £25.90
12-Way	517-320	1+ £29.90 5+ £28.40

CONNECTORS

Power Distribution

EMO C604

19 Inch Power Distribution

A 19 inch rack mountable distribution panel with 16amp Ceeform inputs and a directly looped Ceeform output.



- 4x 13amp MK sockets on the front panel plus four identical sockets on the rear

Description	Code	Price (Ex VAT)
C604	406-710	1+ £165.00 2+ £159.00

VISIT
our trade counter
You'll get friendly advice and immediate access to 8000+ product lines!
free parking for 40 cars

MORE PRODUCTS
online

CONNECTORS

Power Distribution

CONTINUED

Kelsey Power Distribution



Popular range of power distribution units to suit all needs!

The most common problem with power distribution units is that there are never enough AC outlet sockets, the inlet cable has an unusual connector, the captive AC cable is not long enough and the unit cannot be linked to others. Mindful of all these normal restrictions Kelsey have designed new units to overcome most of these disadvantages.

The Kelsey PD Series of AC power distribution panels offers BS4343 16amp or 32amp inlet and outlet connectors to allow linking to other units, an AC trip to allow for restoration of power in the event of overload with optional retrofit RCBO facility, enough outlets to power most racks and an AC status indication system to monitor AC input.



PD7/16 includes a 16amp CEE input and linked output, 1 front panel 13amp sockets and 7 rear panel 13amp sockets.

PD7/32 includes a 32amp CEE input and linked output, 1 front panel 13amp sockets and 7 rear panel 13amp sockets.

PD20/16 includes a 16amp CEE input and linked output- 1 front panel 13A sockets and 20 rear IEC 320 sockets.

PD20/32 includes a 32amp CEE input and linked output- 1 front panel 13A sockets and 20 rear IEC 320 sockets.

Description	Code	Price (Ex VAT)			
PD7/16	450-510	1+	£179.00	2+	£174.00
PD7/32	450-270	1+	£179.00	2+	£174.00
PD20/16	450-520	1+	£157.50	2+	£152.50
PD20/32	450-280	1+	£157.50	2+	£152.50

Samson Powerbrite Series

This series is designed to filter out RFI/EMI problems. All share the same major features as follows.

Powerbrite PB10



The front panel houses 2 slide out cylinders with LED lamps with dimmer control for rack illumination. A gooseneck lamp is included for lighting the rear of the unit.

Powerbrite PB10 Pro



As above but with additional features. Front panel voltmeter and ammeter for measuring voltage and current drawn from the mains supply. 4x IEC power cables included.

PS10 Powerstrip

19" rack mount power conditioner 8 rear-panel IEC plus an additional front-panel convenience outlet. 3-point protection: surge protection, peak voltage spike clamping, and RFI/EMI filtering. Dedicated switch for powering rear-panel switched outlets. Front-panel resettable 10-amp circuit breaker protects all connected gear.

Description	Code	Price (Ex VAT)			
PB10	388-290	1+	£79.16	2+	£74.30
PB10 Pro	388-280	1+	£124.17	2+	£115.50
PS10 Powerstrip	388-300	1+	£49.35	2+	£43.60

MORE PRODUCTS online

CONNECTORS

Power Conditioners

Furman Power Conditioner/Racklights

All Furman PL series include two pull out tubes which house front panel illuminating LEDs and a Dimmer control. All include Series Multistage Extreme Voltage Shutdown powers down equipment during a prolonged or extreme over voltage. There is a rear panel Circuit Breaker. Rear mounted BNC connector with an On/Off switch for any standard gooseneck lamp. Ten rear mounted IEC outlets plus one front panel outlet.

Furman PL-PLUS CE

10 Amp Power Conditioner



Based on the PL-BCE but with a bright LED voltage readout with clear indication of the voltage steps.

Furman PL-PRO DMC E

16 Amp Power Conditioner



Based on the PL-PLUS CE but with a dimmable digital readout covering, Voltage, Current, Protection OK and Extreme Voltage and colour coded Voltage Range Indicators. Front panel USB outlet for charging mobiles.

Furman PL-8CE

10 Amp Power Conditioner

The PL-8CE is the base model for Furman's power conditioning range with a 10 amp total capacity.

Description	Code	Price (Ex VAT)			
PL-Plus CE	470-760	1+	£224.17	2+	£215.00
PL-Pro DMC E	470-770	1+	£395.00	2+	£375.00
PL-8CE	470-750	1+	£195.00	2+	£185.00

Studiospares CP8+1

Clean Power Supply Racklight

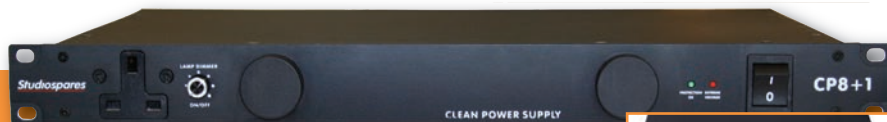

Clean Power and Racklight

Mains-borne interference is frequently referred to as the silent killer. It can corrupt the CPU of digital workstations, take out hard drives and cause havoc with electronic kit that has amplification. Switching on fluorescent lighting can send a huge spike down the mains supply. The CP8+1 provides highly sophisticated multistage surge and spike protection with a response time of 1 nanosecond (0.000 000 001 seconds). The front panel houses the two retractable and dimmable illumination lamps and a spare 13amp socket. LEDs indicate Protection On and Extreme Voltage. The rear panel includes four 13amp UK sockets plus four IEC Equipment sockets. The BNC socket provides for a gooseneck lamp to illuminate the rear of the equipment rack, this has its own on-off switch. This unit is re-badged under various names and is normally sold at double or treble our price.

Lamp tubes shown extended

Description	Code	Price (Ex VAT)			
CP8+1	348-160	1+	£74.17	2+	£69.50



ART PB4x4

Power Conditioner



A well engineered Power Conditioner designed to suit the majority of live and recording applications.

- Housed in a 1U rack case with 8 rear mounted IEC outlet sockets
- 15 amp circuit breaker with a total capacity of 1800 watts
- To avoid troublesome clicks and short term power surges the PB4x4 includes EMI & RFI Filtering with additional Protection Circuitry for surges and spikes

Description	Code	Price (Ex VAT)			
PB4X4 Pro	325-410	1+	£49.17	2+	£42.50

Furman M10X/LX E

Power Conditioner



Units power up and protect equipment up to a 10 amp load.

- 10 rear panel outlets and 1 front panel outlet
- LED indicates equipment is being protected.
- Dimmable illumination on the M10LX E
- Perfect low-cost AC power solution for any rack mount system

Description	Code	Price (Ex VAT)			
M10X E	470-870	1+	£82.00	5+	£81.00
M10LX E	470-880	1+	£119.00	5+	£115.00

CONNECTORS

Power Sequencers

Studiospares Trojan SPS06

Power Sequencer with 13A UK Outlets



The Trojan includes mains filtering including over voltage filtering which offers protection to the associated equipment. The system is managed by an SCM system, (Single Chip Mickey control). Two integral pull out LED front panel lights illuminate the front panel and equipment mounted below. The mains voltage is displayed which can be a useful alert for engineers if the voltage begins to fall through loading considerations. The rear panel houses 6x 13A UK sockets. The maximum load on any one socket is 13 amps. The unit follows a set power up sequence with 3 second delays between outputs. The reverse follows power down. A by-pass switch disables the sequencing program. No 13amp plug is fitted. The substantial mains lead has crimps with eyes for wiring into industrial connectors.

13 amp 6 outlet Power Sequencer...



Back

Description	Code	Price (Ex VAT)
SPS06	348-010	1+ £157.50 2+ £143.00

CONNECTORS

Guitar Pedal Power Supplies

QTX Power Bank 9V DC

Power bank for simultaneous connection of up to 10 effects pedals.

- 2.1mm DC sockets with negative centre polarity
- On/Off power switch with integral LED
- Supplied with ten 280mm DC-DC power leads
- Mains adaptor supplied
- Power supply 12Vdc, 1A



QTX Power Bank 9V/18V DC

A lightweight, compact power bank with 6 x 9Vdc and 4 x 18Vdc outputs.

- For simultaneous connection of up to 10 effects pedals
- 2.1mm DC sockets with negative centre polarity
- Housed in a robust ABS plastic case
- On/Off power switch with integral LED
- Ten 280mm DC-DC power leads
- Mains adaptor supplied



Description	Code	Price (Ex VAT)
Power Bank 9V	475-780	1+ £29.70 2+ £27.90
Power Bank 9V/18V	475-790	1+ £38.40 2+ £36.20

Behringer PSU-HSB-ALL

DC Power Adaptor

A really versatile DC Power Adaptor

- 1.7A current capacity can power more than 20 effects pedals
- Supplied with a full complement of connectors and jumper cords
- Includes 4 assorted jumper cables and 2 daisy-chain cables each with 5 connectors
- Transformerless design
- Runs on any AC power supply from 100 – 240 V



Description	Code	Price (Ex VAT)
PSU-HSB-ALL	382-140	1+ £20.83 2+ £23.75

Behringer PSU-SB 9V

DC Power Adaptor

9 volt 100mA DC Power Adaptor

- 100mA current capacity to power even digital products
- Converts to DC 9 V for use with virtually all stomp boxes and effects pedals
- DC-type 2.2 mm plug with negative tip and positive sleeve
- High-quality components
- exceptionally rugged construction ensure long life



Description	Code	Price (Ex VAT)
PSU-SB 9V	382-150	1+ £8.33 2+ £7.91

CONNECTORS

Low Voltage Power Supplies

Regulated Power Adaptor 1.2A

Specially selected by Studiospares as they have a Regulated output.

- Outputs 3,4,5,6,7,5,9 and 12volts @ 1.2A
- Inc 6 pin in adaptors mm 1.5, 2.1, 2.5, Walkman + 2.5mm and 3.5mm Mini Jacks. Reversible polarity.



Description	Code	Price (Ex VAT)
1.2A	402-725	1+ £15.96 4+ £14.36

1000s of products Available from stock!

VISIT our trade counter

You'll get friendly advice and immediate access to 8000+ product lines!

DELIVERY BEFORE NOON no problem

SATURDAY DELIVERY no problem

ALL PRICES EXCLUSIVE OF VAT.

INDEX

Leads + Looms + Snakes		
Leads	XLR	250
	Jack	255
	Guitar	258
	Headphone	259
	Armoured	260
	Phono RCA	260
	Bantam	260
	Mini Jack	261
	Patch Cords	262
	Wordclock	263
	Guitar Pedal	264
	Digital	264
	Y Leads	264
	Insert	265
	DMX	265
	iPhone/iPod	265
	Speaker	266
	MIDI	267
	Computer	268
	Optical	268
	Firewire/USB	269
	Video	270
Looms		270
Snakes		272

LEADS

XLR Leads

XLR Leads With Neutrik Black Plugs

Pro-Neutrik-Sommer Leads With Gold/Silver PINS

Neutrik Black bodied connectors and Sommer cable provide a combination, second to none.



- Gold versions have Gold plated pins for greater reliability particularly when they remain plugged in for extended periods.

Description	Code	Price (Ex VAT)		
Silver Pin Blk/Blk 1m	594-290	1+	£10.94	10+ £9.82
Silver Pin Blk/Blk 5m	594-300	1+	£14.22	10+ £12.63
Silver Pin Blk/Blk 10m	594-310	1+	£18.12	10+ £16.44
Gold Pin Gld/Blk Gld 1m	594-320	1+	£11.99	10+ £10.87
Gold Pin Gld/Blk Gld 5m	594-330	1+	£15.18	10+ £13.67
Gold Pin Gld/Blk Gld 10m	594-340	1+	£18.96	10+ £17.16

Right-Angled Neutrik XLR Leads

Pro-Neutrik-Sommer Right-Angled XLR Leads

Right angled leads are VERY practical.



- Take up less rear space behind rack mounted equipment.
- If the lead has a sideways tug then the reduced leverage reduces pressure on the equipment's input/output connector.

Description	Code	Price (Ex VAT)		
XLR Fe - R/A XLR Ma 1m	594-350	1+	£12.84	10+ £11.57
XLR Fe - R/A XLR Ma 5m	594-360	1+	£15.93	10+ £14.31
XLR Fe - R/A XLR Ma 10m	594-370	1+	£19.68	10+ £17.86
XLR Ma - R/A XLR Fe 1m	594-380	1+	£12.48	10+ £11.15
XLR Ma - R/A XLR Fe 5m	594-390	1+	£15.43	10+ £13.96
XLR Ma - R/A XLR Fe 10m	594-400	1+	£19.35	10+ £17.38

Studiospares Moulded XLR Leads

A quality product designed to last a lifetime.

A co-ordinated range of leads designed for all stage and studio applications. Lapped 64 strand OFC copper screening for the ultimate rejection of RFI interference whilst retaining flexibility. Low loss cable maintains the high frequencies. Extra strong bonding between cable and connector.

Plug A	Plug B	Length	Code	Price (Ex VAT)			
		1.0m	591-000	1+	£4.05	10+	£3.65
		3.0m	591-010	1+	£4.80	10+	£4.33
		6.0m	591-020	1+	£5.61	10+	£5.05
		10m	591-030	1+	£7.64	10+	£6.89
XLR Male	XLR Female	25m	591-040	1+	£11.17	10+	£10.67

Plug A	Plug B	Length	Code	Price (Ex VAT)			
		1.0m	591-050	1+	£3.86	10+	£3.49
		6.0m	591-060	1+	£5.06	10+	£4.56
		10m	591-070	1+	£7.08	10+	£6.37

Plug A	Plug B	Length	Code	Price (Ex VAT)			
		1.0m	591-110	1+	£3.86	10+	£3.49
		6.0m	591-120	1+	£5.06	10+	£4.56
		10m	591-130	1+	£7.08	10+	£6.37

Plug A	Plug B	Length	Code	Price (Ex VAT)			
		1.0m	591-080	1+	£4.75	10+	£4.27
		6.0m	591-090	1+	£6.13	10+	£5.52
		10m	591-100	1+	£8.03	10+	£7.23

Plug A	Plug B	Length	Code	Price (Ex VAT)			
		1.0m	591-140	1+	£4.75	10+	£4.27
		6.0m	591-150	1+	£6.13	10+	£5.52
		10m	591-160	1+	£8.03	10+	£7.23

Plug A	Plug B	Length	Code	Price (Ex VAT)			
		1.0m	591-170	1+	£4.36	10+	£3.93
		6.0m	591-180	1+	£5.62	10+	£5.06
		10m	591-190	1+	£7.34	10+	£6.61

Plug A	Plug B	Length	Code	Price (Ex VAT)			
		1.0m	591-200	1+	£4.36	10+	£3.93
		6.0m	591-210	1+	£5.62	10+	£5.06
		10m	591-220	1+	£7.34	10+	£6.61

Plug A	Plug B	Length	Code	Price (Ex VAT)			
		1.0m	591-260	1+	£4.36	10+	£3.93
		6.0m	591-270	1+	£5.62	10+	£5.06
		10m	591-280	1+	£7.34	10+	£6.61

Plug A	Plug B	Length	Code	Price (Ex VAT)			
		1.0m	591-230	1+	£4.36	10+	£3.93
		6.0m	591-240	1+	£5.62	10+	£5.06
		10m	591-250	1+	£7.34	10+	£6.61



DELIVERY BEFORE NOON **no problem** SATURDAY DELIVERY **no problem**

Economy XLR and Jack Leads



A range of the most popular sized XLR and Jack leads.







XLRs are die cast and have no screws. The cable is compressed by the chuck principle when the top is tightened. The all metal Jack plugs have an exterior moulded-on rubber type grip and a really effective spring strain relief for absolute reliability. The cable retention is very positive. A 64 strand x 0.12mm lapped copper screen ensures excellent flexibility and screening. Low DC losses are ensured by the use of 20 strands of 0.12mm copper wire. These leads are manufactured in accordance with ISO9001 and are imported by Studiospares in container loads hence the highly competitive prices.



Plug A	Plug B	Length	Balanced/Unbalanced	Code	Price (Ex VAT)					
		0.3m	Balanced	590-160	1+	£2.86	10+	£2.58	30+	£2.29
		0.6m	Balanced	590-170	1+	£3.09	10+	£2.78	30+	£2.48
		1m	Balanced	589-420	1+	£3.11	10+	£2.79	30+	£2.48
		2.5m	Balanced	589-430	1+	£3.59	10+	£3.23	30+	£2.87
		5m	Balanced	588-270	1+	£4.22	10+	£3.74	30+	£3.34
		10m	Balanced	588-280	1+	£6.26	10+	£5.62	30+	£4.99
XLR Female	XLR Male	25m	Balanced	589-440	1+	£12.92	10+	£11.66	30+	£10.41



Plug A	Plug B	Length	Colour	Code	Price (Ex VAT)					
XLR Female	XLR Male	5m	Red	588-272	1+	£4.22	10+	£3.74	30+	£3.34
XLR Female	XLR Male	5m	Green	588-275	1+	£4.22	10+	£3.74	30+	£3.34
XLR Female	XLR Male	5m	Blue	588-276	1+	£4.22	10+	£3.74	30+	£3.34
XLR Female	XLR Male	10m	Red	588-282	1+	£6.26	10+	£5.62	30+	£4.99
XLR Female	XLR Male	10m	Green	588-285	1+	£6.26	10+	£5.62	30+	£4.99
XLR Female	XLR Male	10m	Blue	588-286	1+	£6.26	10+	£5.62	30+	£4.99

Plug A	Plug B	Length	Balanced/Unbalanced	Code	Price (Ex VAT)					
		1m	Unbalanced	589-450	1+	£3.13	10+	£2.83	30+	£2.60
		2.5m	Unbalanced	589-460	1+	£3.56	10+	£3.22	30+	£2.87
		5m	Unbalanced	588-290	1+	£4.58	10+	£4.19	30+	£3.76
XLR Female	Mono Jack	10m	Unbalanced	590-180	1+	£6.15	10+	£5.52	30+	£4.89

Plug A	Plug B	Length	Balanced/Unbalanced	Code	Price (Ex VAT)					
		1m	Balanced	589-480	1+	£3.93	10+	£3.55	30+	£3.14
		2.5m	Balanced	589-490	1+	£4.28	10+	£3.81	30+	£3.38
		5m	Balanced	588-300	1+	£4.65	10+	£4.17	30+	£3.75
XLR Female	Stereo Jack	10m	Balanced	589-500	1+	£6.70	10+	£5.99	30+	£5.36

Plug A	Plug B	Length	Balanced/Unbalanced	Code	Price (Ex VAT)					
		1m	Unbalanced	590-190	1+	£3.89	10+	£3.51	30+	£3.12
		2.5m	Unbalanced	590-200	1+	£4.24	10+	£3.82	30+	£3.39
		5m	Unbalanced	588-520	1+	£4.81	10+	£4.28	30+	£3.77
XLR Male	Mono Jack	10m	Unbalanced	590-210	1+	£6.56	10+	£5.91	30+	£5.25

Plug A	Plug B	Length	Balanced/Unbalanced	Code	Price (Ex VAT)					
		1m	Balanced	589-510	1+	£3.72	10+	£3.44	30+	£3.07
		2.5m	Balanced	589-520	1+	£4.19	10+	£3.85	30+	£3.43
		5m	Balanced	588-310	1+	£4.65	10+	£4.17	30+	£3.75
XLR Male	Stereo Jack	10m	Balanced	589-540	1+	£6.70	10+	£5.99	30+	£5.36

Plug A	Plug B	Length	Balanced/Unbalanced	Code	Price (Ex VAT)					
		1m	Balanced	589-570	1+	£4.16	10+	£3.74	30+	£3.32
		2.5m	Balanced	590-220	1+	£5.22	10+	£4.70	30+	£4.18
		5m	Balanced	589-580	1+	£6.11	10+	£5.49	30+	£4.89
		10m	Balanced	590-230	1+	£6.88	10+	£6.19	30+	£5.50

ALL PRICES EXCLUSIVE OF VAT.

LEADS

XLR Leads



CONTINUED

Studiospares Pro XLR Leads



Probably the UK's most popular series of professional leads!

Combining the two greatest names in cable and connectors, Sommer and Neutrik, assures uncompromising quality. The Phono plugs are the highest quality we can find, bar none. No more playing with plugs to stop that intermittent connection half way through a gig or session. Manufactured in the UK to the highest professional standards. Available in 282 various options. See below for details of coloured XLR lead options.

Plug A	Plug B	Length	Code	Price (Ex VAT)							
		0.3m	593-000	1+	£9.82	3+	£8.89	10+	£7.96	25+	£7.38
		0.6m	579-150	1+	£9.94	3+	£9.07	10+	£8.13	25+	£7.47
		1.0m	573-330	1+	£10.28	3+	£9.42	10+	£8.51	25+	£7.64
		2.0m	593-010	1+	£10.99	3+	£10.07	10+	£9.02	25+	£8.46
		2.5m	579-160	1+	£11.47	3+	£10.48	10+	£9.49	25+	£8.66
		3.5m	593-020	1+	£12.17	3+	£11.09	10+	£9.99	25+	£8.95
		5.0m	574-711	1+	£13.28	3+	£12.22	10+	£10.99	25+	£9.93
		7.0m	593-030	1+	£14.76	3+	£13.63	10+	£12.23	25+	£11.14
		10m	574-721	1+	£16.96	3+	£15.48	10+	£13.99	25+	£12.73
		15m	593-040	1+	£20.79	3+	£18.98	5+	£18.24	10+	£17.26
		20m	593-050	1+	£24.59	3+	£22.99	5+	£21.62	10+	£20.38
		25m	579-170	1+	£27.98	3+	£25.81	5+	£24.62	10+	£23.19
Neutrik XLR Male	Neutrik XLR Female	50m	579-620	1+	£43.98	3+	£40.46	5+	£38.70	10+	£36.50

Plug A	Plug B	Length	Code	Price (Ex VAT)							
		0.6m	579-030	1+	£10.06	3+	£9.04	10+	£8.10	25+	£7.35
		1.0m	571-230	1+	£10.36	3+	£9.44	10+	£8.62	25+	£7.85
		2.5m	571-240	1+	£11.45	3+	£10.56	10+	£9.54	25+	£8.54
		5.0m	574-501	1+	£13.29	3+	£12.31	10+	£11.44	25+	£10.56
		10m	571-260	1+	£17.35	3+	£16.03	10+	£14.58	25+	£13.10
Neutrik XLR Male	Neutrik Mono Jack	25m	571-300	1+	£27.55	2+	£26.10	3+	£24.70	6+	£23.20

Plug A	Plug B	Length	Code	Price (Ex VAT)							
		0.6m	579-020	1+	£10.67	3+	£9.53	10+	£8.58	25+	£7.76
		1.0m	571-210	1+	£10.92	3+	£9.63	10+	£8.80	25+	£7.91
		2.5m	571-220	1+	£11.77	3+	£10.89	10+	£9.93	25+	£8.94
		5.0m	574-530	1+	£13.55	3+	£12.44	10+	£11.37	25+	£10.31
		10m	571-250	1+	£17.56	3+	£16.20	10+	£14.65	25+	£13.46
Neutrik XLR Female	Neutrik Mono Jack	25m	571-290	1+	£27.70	2+	£26.30	3+	£24.90	6+	£23.45

Plug A	Plug B	Length	Code	Price (Ex VAT)							
		0.6m	579-180	1+	£8.20	3+	£7.54	10+	£6.81	25+	£6.16
		1.0m	579-190	1+	£8.53	3+	£7.85	10+	£7.05	25+	£6.40
		2.5m	579-200	1+	£9.68	3+	£8.89	10+	£8.02	25+	£7.27
		5.0m	574-470	1+	£11.45	3+	£10.64	10+	£9.68	25+	£8.79
		10m	579-210	1+	£15.44	3+	£14.25	5+	£13.63	10+	£12.87
Neutrik XLR Male	Precision Phono										

Plug A	Plug B	Length	Code	Price (Ex VAT)							
		0.6m	579-220	1+	£8.53	3+	£7.82	10+	£7.11	25+	£6.41
		1.0m	579-230	1+	£8.81	3+	£8.12	10+	£7.32	25+	£6.63
		2.5m	579-240	1+	£9.98	3+	£9.18	10+	£8.29	25+	£7.51
		5.0m	574-460	1+	£11.83	3+	£10.94	10+	£9.99	25+	£9.11
		10m	579-250	1+	£15.36	3+	£14.53	5+	£13.59	10+	£11.98
Neutrik XLR Female	Precision Phono										

Studiospares Pro XLR Leads



Plug A	Plug B	Length	Code	Price (Ex VAT)							
		0.6m	579-080	1+	£10.67	3+	£9.64	10+	£8.72	25+	£7.88
		1.0m	571-270	1+	£10.96	3+	£10.08	10+	£8.99	25+	£8.22
		2.5m	571-280	1+	£11.92	3+	£10.96	10+	£9.90	25+	£8.58
		5.0m	574-540	1+	£13.97	3+	£12.91	10+	£11.64	25+	£10.54
		10m	579-090	1+	£17.46	3+	£16.24	5+	£15.34	10+	£14.30
Neutrik XLR Male	Neutrik Stereo Jack	25m	579-100	1+	£28.48	3+	£26.24	5+	£25.22	10+	£23.68

Plug A	Plug B	Length	Code	Price (Ex VAT)							
		0.6m	593-100	1+	£11.16	3+	£10.44	10+	£9.39	25+	£8.56
		1.0m	579-110	1+	£11.51	3+	£10.80	10+	£9.67	25+	£8.77
		2.5m	579-120	1+	£12.85	3+	£11.73	10+	£10.82	25+	£9.52
		5.0m	574-550	1+	£14.54	3+	£13.36	10+	£12.21	25+	£11.14
		10m	579-130	1+	£18.54	3+	£17.29	10+	£16.32	10+	£15.48
Neutrik XLR Female	Neutrik Stereo Jack	25m	579-140	1+	£28.87	3+	£26.63	5+	£25.41	10+	£24.23

Studiospares Pro XLR Lead Packs

XLR Male - XLR Female Black 5 Packs

5 Packs of the most popular leads, with Black Sommer microphone cable and Neutrik plugs for ultimate performance.

XLR Male - XLR Female Coloured 6 Packs

6 cables for the price of 5! Make it easier to see which cable is going where with our multicoloured XLR lead packages. 6 different colours.

Plug A	Plug B	Length	Code	Price (Ex VAT)			
		5m (5 x 574-711)	595-600	1+	£51.50	3+	£49.50
		10m (5 x 574-721)	595-610	1+	£66.50	3+	£64.50
Neutrik XLR Male	Neutrik XLR Female	5m (6 x Coloured XLR Leads)	574-719	1+	£61.50	3+	£58.50
		10m (6 x Coloured XLR Leads)	574-729	1+	£79.10	3+	£75.30

BLACK

GREEN

RED

BLUE

YELLOW

VIOLET

COLOURED LEADS NOW AT NO EXTRA CHARGE!!!

The Studiospares Professional XLR leads are available in five colours in addition to Black. To order a coloured lead simply substitute the last digit of the code number for the following:

- Black = 0
- Red = 2
- Yellow = 4
- Green = 5
- Blue = 6
- Violet = 7

For example the 0.3 metre lead Neutrik XLR Male to Neutrik Female XLR in Black is 593-000. In Red it would become 593-002 and in Blue 593-006. Popular versions are held in stock but delivery time can be up to 7 working days.



Klotz M5

XLR Leads

Klotz products focus on quality and are accepted as being the best.

- Utilise the finest Black Neutrik NC3FXXB/NC3MXXB connectors with Gold contacts
- Klotz MC5000 cable with two counter wound copper screens
- Inner jacket stabilises the cable to stop it kinking and twisting
- Conductors use generous amounts of copper (0.5mm²)



Armour Shielded Highly Flexible Leads

XLR + Jack Leads

The ultimate in strength and reliability.

- The stainless steel shield is moulded into stoppers located inside the connector
- More flexible than conventional plastic jacketed cables
- Internal shield is of spirally wound copper
- Die cast female XLR includes two raised pressure points



Description	Code	Price (Ex VAT)			
XLR Ma - XLR Fe 5m	588-600	1+	£12.92	10+	£11.64
XLR Ma - XLR Fe 10m	588-610	1+	£18.80	10+	£16.90
XLR Fe - Straight Jk 5m	588-730	1+	£10.40	10+	£9.35
XLR Fe - Straight Jk 10m	588-740	1+	£14.75	10+	£13.75

Mogami XLR Leads

XLR + Jack Leads

Highly flexible even at -20 degrees. Add Neutrik connectors for the ultimate lead.

- Cable is 2534 Neglex oxygen free copper quad Mogami Reference Microphone Cable
- Its balanced quad structure reduces electromagnetic induction



Description	Code	Price (Ex VAT)			
XLR Ma - XLR Fe 1m	501-000	1+	£27.49	5+	£26.11
XLR Ma - XLR Fe 3m	501-010	1+	£32.49	5+	£30.86
XLR Ma - XLR Fe 5m	501-020	1+	£37.49	5+	£35.62
XLR Ma - XLR Fe 10m	501-030	1+	£49.99	5+	£47.49
XLR Fe - St Jack 5m	501-040	1+	£39.16	5+	£37.26
XLR Ma - St Jack 5m	501-050	1+	£38.32	5+	£36.40

Description	Code	Price (Ex VAT)			
M5 3m	514-200	1+	£19.40	10+	£17.46
M5 6m	514-210	1+	£23.60	10+	£21.24
M5 10m	514-220	1+	£28.30	10+	£25.47

LEADS

XLR Leads



CONTINUED



Studiospares Performance Plus Leads



XLR Leads



Improved cable screening and ID options - still at a modest price.



Performance Plus are a new range of XLR leads which use cable with improved braided screening which doesn't kink. Plugs have coloured rings that can be easily changed. Spare rings (6 colours) supplied with each lead.

Plug A	Plug B	Length	Code	Price (Ex VAT)					
		1.0m	590-340	1+	£5.92	10+	£5.33	30+	£4.74
		5.0m	590-350	1+	£7.46	10+	£6.71	30+	£5.96
XLR Male	XLR Female	10m	590-360	1+	£8.81	10+	£7.93	30+	£7.05

Plug A	Plug B	Length	Code	Price (Ex VAT)					
		1.0m	590-370	1+	£5.98	10+	£5.38	30+	£4.78
		5.0m	590-380	1+	£7.63	10+	£6.87	30+	£6.11
XLR Male	Mono Jack	10m	590-390	1+	£8.86	10+	£7.97	30+	£7.08

Plug A	Plug B	Length	Code	Price (Ex VAT)					
		1.0m	590-400	1+	£6.11	10+	£5.50	30+	£4.89
		5.0m	590-410	1+	£7.74	10+	£6.97	30+	£6.20
XLR Female	Mono Jack	10m	590-420	1+	£8.97	10+	£8.07	30+	£7.17

Plug A	Plug B	Length	Code	Price (Ex VAT)					
		1.0m	590-430	1+	£5.72	10+	£5.15	30+	£4.58
		5.0m	590-440	1+	£7.45	10+	£6.70	30+	£5.95
XLR Male	Stereo Jack	10m	590-450	1+	£8.59	10+	£7.73	30+	£6.87

Plug A	Plug B	Length	Code	Price (Ex VAT)					
		1.0m	590-460	1+	£5.84	10+	£5.26	30+	£4.68
		5.0m	590-470	1+	£7.52	10+	£6.77	30+	£6.02
XLR Female	Stereo Jack	10m	590-480	1+	£8.73	10+	£7.86	30+	£6.99

AES/EBU Leads

XLR Leads

A range of dedicated AES/EBU leads.

- Using Neutrik Digital XLRs and Sommer Binary AES/EBU 110Ω cable
- Three lengths



Description	Code	Price (Ex VAT)			
1m	580-020	1+	£17.92	5+	£16.35
3m	580-030	1+	£19.82	5+	£17.75
5m	580-040	1+	£22.32	5+	£20.58

Mini XLR Leads

Uses the highest quality components.

- XLRfe from Neutrik, the Mini XLR from Switchcraft, and Sommer Cable
- Made by Studiospares



Description	Code	Price (Ex VAT)			
Mini XLR M - XLR F 1m	594-540	1+	£13.80	10+	£12.42
Mini XLR M - XLR F 2.5m	594-550	1+	£14.70	10+	£13.23
Mini XLR M - XLR F 5m	594-560	1+	£16.20	10+	£14.58

XLR Leads With Neutrik Connectors



These connectors clearly have a heavy European influence. They include all the features that have made Neutrik No 1. The connectors include the chuck cable grip, the soft seal on the female version, the retention clip, the connection block and the looks of the famed original styling. The cable is a quality low loss OFC copper with a spirally wound screen. Manufactured in accordance with ISO9001.

Description	Code	Price (Ex VAT)			
XLR male-female 5m	590-140	1+	£7.93	10+	£7.14
XLR male-fem 5m 5-Pack	590-149	1+	£35.69	10+	£33.90
XLR male-female 10m	590-150	1+	£9.88	10+	£8.90
XLR male-fem 10m 5-Pack	590-159	1+	£44.46	10+	£42.50

5 Pin XLR Leads

XLR Leads

Two lengths, 1m and 5m.

- Stereo microphones use two balanced outputs on one XLR so have to resort to a 5 pin XLR
- Leads are separate but moulded together
- This lead converts the 5 pin female XLR to two 3 pin male XLRs



Description	Code	Price (Ex VAT)			
1m	589-160	1+	£4.40	10+	£3.95
5m	589-170	1+	£6.40	10+	£5.75

3 Pin Mini Lead (Tiny QG)

XLR Leads

Mates with Switchcraft Tiny QG connectors.

- Male to female with cable bending protection
- 5m long



Description	Code	Price (Ex VAT)			
3 Pin Mini XLR Lead	595-660	1+	£10.42	10+	£9.42

MORE PRODUCTS online

Dual 2x XLR Male - 2x Phono

XLR Leads

Metal RCA Phono plugs with Red, Black ID bands and spring strain relief.

- 2 x XLR plugs to 2 x RCA Phono plugs
- Individually shielded conductors
- Low-noise, heavy duty Fig. 8 cable



Description	Code	Price (Ex VAT)			
2x XLR Ma-2x Phono 1.5m	582-500	1+	£8.95	5+	£8.05
2x XLR Ma-2x Phono 3m	582-510	1+	£9.75	5+	£8.77
2x XLR Fe-2x Phono 1.5m	582-520	1+	£8.95	5+	£8.05
2x XLR Fe-2x Phono 3m	582-530	1+	£9.75	5+	£8.77

Neutrik Convertcon

Unisex XLR Leads

New pro leads using the ConvertCon - the world's first combined Male and Female XLR plug!

- One end carries the Neutrik Convertcon unisex XLR connector
- Simply slide the barrel to change sex



Description	Code	Price (Ex VAT)			
Convertcon - Same 5m	595-570	1+	£21.84	3+	£20.35
Convertcon - Jack 5m	595-580	1+	£18.28	3+	£17.03

Jack Leads

LEADS

Short Jack Equipment Patching Leads

Ideal for patching equipment including foot pedals.

- Plugs are moulded to the fully screened lead for enhanced reliability
- High quality components with thick chrome plating for assured contact



Description	Code	Price (Ex VAT)			
0.1m	589-130	1+	£1.87	10+	£1.68
0.2m	589-140	1+	£1.99	10+	£1.79
0.5m	589-180	1+	£2.19	10+	£1.97
1.0m	589-190	1+	£2.57	10+	£2.30

Armour Shielded Highly Flexible Leads

The ultimate in strength, reliability and quality.

- Spiral wound stainless steel screening like old vandal-proof telephone boxes
- High spec single copper core 20 x 0.12mm diameter cable
- Internal antistatic graphite-impregnated tube reduces crackle
- Hard chromed jack plugs



Description	Code	Price (Ex VAT)			
1m	588-640	1+	£4.32	10+	£3.90
2.5m	588-650	1+	£7.92	10+	£7.12
5m	588-710	1+	£10.40	10+	£9.35
10m	588-720	1+	£15.60	10+	£14.10

Studiospares Gold Moulded Leads

Jack Leads



Gold contacts for absolute reliability.

These leads are manufactured in accordance with ISO9001 and are imported by Studiospares in container loads hence the highly competitive prices. OFC lapped copper screening.

Plug A	Plug B	Length	Code	Price (Ex VAT)			
1/4" Jack stereo	1/4" Jack stereo	0.6m	591-290	1+	£3.44	10+	£3.11
1/4" Jack stereo	1/4" Jack stereo	2.5m	591-300	1+	£3.91	10+	£3.52
1/4" Jack stereo	1/4" Jack stereo	5.0m	591-310	1+	£4.97	10+	£4.48
1/4" Jack stereo	1/4" Jack stereo	10m	591-320	1+	£6.65	10+	£5.96

Plug A	Plug B	Length	Code	Price (Ex VAT)			
1/4" Jack mono	1/4" Jack mono	0.6m	591-370	1+	£3.07	10+	£2.76
1/4" Jack mono	1/4" Jack mono	2.5m	591-380	1+	£3.74	10+	£3.37
1/4" Jack mono	1/4" Jack mono	5.0m	591-390	1+	£4.33	10+	£3.90
1/4" Jack mono	1/4" Jack mono	10m	591-400	1+	£5.96	10+	£5.38

Plug A	Plug B	Length	Code	Price (Ex VAT)			
1/4" Jack mono	Phono plug	0.6m	591-410	1+	£2.90	10+	£2.61
1/4" Jack mono	Phono plug	2.5m	591-420	1+	£3.65	10+	£3.28
1/4" Jack mono	Phono plug	5.0m	591-430	1+	£4.18	10+	£3.77
1/4" Jack mono	Phono plug	10m	591-440	1+	£5.69	10+	£5.12

Plug A	Plug B	Length	Code	Price (Ex VAT)			
2 x 1/4" Jack mono	2 x Phono plug	1.0m	591-450	1+	£5.15	10+	£4.63
2 x 1/4" Jack mono	2 x Phono plug	5.0m	591-460	1+	£6.64	10+	£5.97
2x 1/4" Jack mono	2 x 1/4" Jack mono	1.0m	591-470	1+	£4.91	10+	£4.43
2x 1/4" Jack mono	2 x 1/4" Jack mono	5.0m	591-480	1+	£6.26	10+	£5.64

Jack Lead Mono - Stereo 5m

Professional Jack Lead

Provided for Jam Hub users. Can be used for other applications. It either splits a mono signal to L&R inputs or the reverse.

- Cable with comprehensive screening
- Neutrik connectors



Description	Code	Price (Ex VAT)			
Mono Jack - St Jack 5m	579-650	1+	£13.54	5+	£11.96

Mono Jack - Mini Jack Mono

Portable Equipment Interconnection Lead

A useful lead for interconnecting portable and studio equipment.

- Moulded for added reliability
- Quality nickel plated contacts



Description	Code	Price (Ex VAT)			
Mono Jack - Mini Jack	597-420	1+	£6.34	5+	£5.71

Studiospares Moulded Jack Leads

Moulded for absolute reliability.

- A 64 strand x 0.12mm lapped copper screen ensures excellent flexibility
- Low DC losses are ensured by the use of 20 strands of 0.12mm copper wire



Plug A	Plug B	Length	Code		
Straight 1/4" Jack stereo	Straight 1/4" Jack stereo	0.6m	588-320		
Straight 1/4" Jack stereo	Straight 1/4" Jack stereo	2.5m	588-330		
Straight 1/4" Jack stereo	Straight 1/4" Jack stereo	5.0m	588-340		
Straight 1/4" Jack mono	Straight 1/4" Jack mono	0.6m	588-350		
Straight 1/4" Jack mono	Straight 1/4" Jack mono	2.5m	588-360		
Straight 1/4" Jack mono	Straight 1/4" Jack mono	5.0m	588-370		

Description	Code	Price (Ex VAT)			
St Jk - St Jk Stereo 0.6m	588-320	1+	£2.67	10+	£2.39
St Jk - St Jk Stereo 2.5m	588-330	1+	£3.23	10+	£2.96
St Jk - St Jk Stereo 5.0m	588-340	1+	£3.99	10+	£3.58
St Jk - St Jk Mono 0.6m	588-350	1+	£2.45	10+	£2.20
St Jk - St Jk Mono 2.5m	588-360	1+	£2.93	10+	£2.66
St Jk - St Jk Mono 5.0m	588-370	1+	£3.56	10+	£3.22

DELIVERY BEFORE NOON
no problem

SATURDAY DELIVERY
no problem

DELIVERY BEFORE 10AM
no problem

Studiospares Pro Jack Leads

Neutrik NP2X / NP3X Connectors



Neutrik precision die cast connectors with highest quality Sommer cable.

Various length options. Manufactured in the UK to the highest standards. Premium grade cable with premium grade connectors.

Plug A	Plug B	Length	Code	Sommer Cable	Price (Ex VAT)					
	*	0.6m	579-680	Sommer Tricone	1+	£9.68	3+	£8.97	10+	£8.29
		1.0m	579-370	Sommer Tricone	1+	£9.93	3+	£9.15	10+	£8.48
		2.5m	579-380	Sommer Tricone	1+	£11.12	3+	£10.18	10+	£9.26
		5.0m	574-940	Sommer Tricone	1+	£12.74	3+	£11.68	10+	£10.61
		10m	579-280	Sommer Tricone	1+	£15.62	3+	£14.47	10+	£12.96
		15m	593-860	Sommer Tricone	1+	£19.38	3+	£17.77	10+	£16.22
Neutrik Mono Jack	Neutrik Mono Jack	25m	593-870	Sommer Tricone	1+	£25.90	3+	£23.98	10+	£21.82

Plug A	Plug B	Length	Code	Sommer Cable	Price (Ex VAT)					
	*	0.6m	579-290	Sommer Club	1+	£11.60	3+	£10.64	10+	£9.73
		1.0m	579-300	Sommer Club	1+	£11.92	3+	£11.04	10+	£9.99
		2.5m	579-310	Sommer Club	1+	£12.81	3+	£11.78	10+	£10.78
		5.0m	579-320	Sommer Club	1+	£14.66	3+	£13.49	10+	£12.24
		10m	579-330	Sommer Club	1+	£17.72	3+	£16.34	10+	£14.81
		15m	593-900	Sommer Club	1+	£22.25	3+	£20.49	10+	£18.58
Neutrik Stereo Jack	Neutrik Stereo Jack	25m	593-910	Sommer Club	1+	£29.57	3+	£27.26	10+	£24.63

Plug A	Plug B	Length	Code	Sommer Cable	Price (Ex VAT)					
	*	0.6m	579-350	Sommer Tricone	1+	£7.29	3+	£6.78	10+	£6.25
		1.5m	573-050	Sommer Tricone	1+	£7.60	3+	£7.13	10+	£6.59
		2.5m	579-360	Sommer Tricone	1+	£7.92	3+	£7.48	10+	£6.93
		5.0m	573-060	Sommer Tricone	1+	£10.86	3+	£9.88	10+	£8.92
		10m	579-400	Sommer Tricone	1+	£13.48	3+	£12.37	10+	£11.32
Neutrik Mono Jack	Precision Phono Plug									

Plug A	Plug B	Length	Code	Sommer Cable	Price (Ex VAT)					
		0.6m	574-950	Sommer Tricone	1+	£5.53	10+	£4.95	25+	£4.44
		2.5m	574-370	Sommer Tricone	1+	£6.15	10+	£5.55	25+	£5.07
		5.0m	579-270	Sommer Tricone	1+	£6.73	3+	£6.05	25+	£5.56
Insulated Mono Jack	Insulated Mono Jack									

Plug A	Plug B	Length	Code	Moulded Cable	Price (Ex VAT)					
		0.9m	574-090	Moulded Cable	1+	£4.11	10+	£3.70	25+	£3.29
		2.5m	579-260	Moulded Cable	1+	£4.96	3+	£4.48	25+	£3.99
		4.5m	579-340	Moulded Cable	1+	£6.94	10+	£6.25	25+	£5.96
Insulated Mono Jack	Moulded Phono Plug									

BLACK COLOURED LEADS NOW AT NO EXTRA CHARGE!!!

- RED**
- BLUE**
- GREEN**

* Starred leads are available in three colours in addition to Black. To order a coloured lead simply substitute the last digit of the code number for the following:
 Red = 2 Green = 5 Blue = 6

For example the 0.6 metre lead Neutrik Mono Jack to Phono in Black is 579-350. In Red it would become 579-352 and in Blue 579-356. All versions are generally in stock but delivery time could be up to 7 working days.

Moulded Insert/Y Leads

A range of useful moulded leads to make interfacing equipment quicker and easier.

- 4mm diameter lapped copper screened cable
- Nickel plated contact surfaces
- Strain relief reduces fatigue problems



Plug A	Plug B	Length	Code
Stereo Jack Plug (insert)	2x Phono Sockets	0.1m	579-010
Mono Jack Plug (Y lead)	2x Phono Plugs	2.0m	589-670
Mono Jack Plug (Y lead)	2x Phono Plugs	3.0m	595-180
Mono Jack Plug (Y lead)	2x Phono Sockets	0.1m	574-990
Mono Jack Socket (Y lead)	2x Phono Sockets	0.1m	574-860

Description	Code	Price (Ex VAT)			
St Jk - 2 Phono Skt 0.1m	579-010	1+	£3.45	5+	£2.98
Mono Jk - 2 Phono 2m	589-670	1+	£1.49	10+	£1.44
Mono Jk - 2 Phono 3m	595-180	1+	£4.48	3+	£3.99
Mono Jk - 2 Phono Skt 0.1m	574-990	1+	£3.28	10+	£2.83
M Jk Skt-2 Phn Skt 0.2m	574-860	1+	£2.59	10+	£2.32

Pro Jack Leads With Black Plugs

The ultimate in performance and reliability.

- Black Neutrik connectors with nickel plated contacts and Sommer Cable



Description	Code	Price (Ex VAT)			
Jk - St Jk Black 1m	594-410	1+	£10.92	10+	£9.88
Jk - St Jk Black 5m	594-420	1+	£13.91	10+	£12.56
Jk - 5 Jk Black 10m	594-430	1+	£17.94	10+	£16.08
Jk - Mono Jk Black 1m	594-440	1+	£9.95	10+	£8.93
Jk - Mono Jk Black 5m	594-450	1+	£12.64	10+	£11.36
Jk - Mono Jk Black 10m	594-460	1+	£15.96	10+	£14.44

Klotz Jack-Jack Leads

A multipurpose lead suitable for the interconnection of guitar lead, patch lead and equipment.

- Connectors have a metal shell which is surrounded by a thick rubberised jacket moulded onto the shell
- The cable is a low capacity version which includes a conductive plastic tube surrounding the centre core



Description	Code	Price (Ex VAT)			
Monojack 1.5m	514-230	1+	£9.23	10+	£8.31
Monojack 3m	514-240	1+	£10.65	10+	£9.59
Monojack 6m	514-250	1+	£13.36	10+	£12.22

Mogami Jack Lead 6m

Stereo Jack - Stereo Jack

Mogami Cable has remained No1 for over a decade. Highly flexible even at -20 degrees. Add Neutrik connectors for the ultimate lead.

- Cable is 2534 Neglex oxygen free copper quad Mogami Reference Microphone Cable
- It's balanced quad structure reduces electromagnetic induction



Description	Code	Price (Ex VAT)			
St Jack - St Jack	501-060	1+	£39.99	5+	£37.99

Studiospares Jack/Splitter Y Leads

Gold Plated Jack Leads



Designed for Splitter/Combiner/Y Lead applications.

They are moulded and with care will last a lifetime. Gold plated connectors are used where indicated. Plug outline may vary from illustrations.

Plug A	Plug B	Length	Code	Price (Ex VAT)			
Stereo Jack	2 x Phono	2.0m	592-020	1+	£4.96	10+	£4.47
Stereo Jack	2 x Mono Jack	1.0m	591-990	1+	£4.68	10+	£4.24
Stereo Jack	2 x Mono Jack	2.0m	592-000	1+	£5.21	10+	£4.69
Stereo Jack	2 x Mono Jack	4.0m	592-010	1+	£7.18	10+	£6.46
Stereo Jack	2 x Mono Jack Socket	0.2m	591-790	1+	£4.24	10+	£3.82
Stereo Jack	1 x XLR Male + 1 x XLR Fem	2.0m	591-970	1+	£8.44	10+	£7.60
Stereo Jack	1 x XLR Male + 1 x XLR Fem	4.0m	591-980	1+	£9.44	10+	£8.50
Stereo Jack	2 x Stereo Jack	0.2m	591-800	1+	£4.24	10+	£3.82
Stereo Jack	2 x Stereo Mini Jack Sockets	0.2m	591-810	1+	£4.56	10+	£4.11
Stereo Jack	2 x Stereo Jack Sockets	0.2m	591-820	1+	£4.92	10+	£4.53

Plug A	Plug B	Length	Code	Price (Ex VAT)			
Stereo Jack Socket	2 x Mono Jack	0.2m	591-830	1+	£4.46	10+	£4.02
Stereo Jack Socket	2 x Stereo Jack	0.2m	591-840	1+	£4.74	10+	£4.27

Plug A	Plug B	Length	Code	Price (Ex VAT)			
Mono Jack	2 x Mono Jack Sockets	0.2m	591-870	1+	£3.84	10+	£3.46
Mono Jack Socket	2 x Mono Jack	0.2m	591-880	1+	£4.46	10+	£4.02

Nickel Plated Dual Jack - Jack Leads

Designed to provide the best in equipment interconnection.

- Nickel plated connectors with a high grade dual cable
- Oxygen Free Copper for the spirally wound screen and the conductor
- Traditional Jack connectors which will last a lifetime



Description	Code	Price (Ex VAT)			
1.2m	596-060	1+	£12.12	10+	£10.93
4.5m	596-070	1+	£15.82	10+	£14.23

2x Mono Jack - 2x Phono Plugs 3m

Pro Neutrik/Sommer Dual Leads

Dual leads are convenient and make replugging equipment easier and saves time.

- Connectors are Neutrik NP2 and an industrial grade Gold Phono plug with an effective strain relief
- Cable is Sommer Onyx



Description	Code	Price (Ex VAT)			
2x Mono Jk - 2x Phono 3m	594-530	1+	£15.99	10+	£14.42

Studiospares Performance Plus Jack Leads

Improved cable screening and ID options at a modest price.

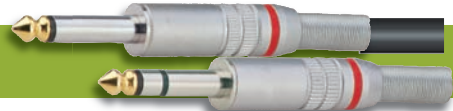

Plugs have coloured ident rings which are easily changed. Spare coloured rings supplied with each lead. OFC cable.

Plug A	Plug B	Length	Code	Price (Ex VAT)			
Mono Jack	Mono Jack	1.0m	590-490	1+	£6.38	10+	£5.75
Mono Jack	Mono Jack	5.0m	590-500	1+	£7.23	10+	£6.51
Mono Jack	Mono Jack	10m	590-510	1+	£8.05	10+	£7.25

Plug A	Plug B	Length	Code	Price (Ex VAT)			
Stereo Jack	Stereo Jack	1.0m	590-520	1+	£5.99	10+	£5.39
Stereo Jack	Stereo Jack	5.0m	590-530	1+	£7.65	10+	£6.89
Stereo Jack	Stereo Jack	10m	590-540	1+	£8.89	10+	£8.00

MORE PRODUCTS online

LEADS

Guitar Leads

Studiospares Silent Guitar Lead

A Professional guitar lead made in the UK with premium grade cable and connectors.

The best guitar lead cable currently available is the double screened Klotz ACT10 with an incredibly low capacity of 70pF/m. In layman's terms this means high frequency losses are zero. Designed to live under performer's feet, the cable includes a heavy duty 7mm diameter PVC matte jacket. The plugs are the Black bodied Neutrik NP2 series with Gold plated connectors. The lead only becomes active when the "Silent" plug is fully inserted into the Jack socket. There are no better connectors whatever the price.



Description	Code	Price (Ex VAT)					
Silent Lead 5m	593-120	1+	£19.35	5+	£18.22	10+	£16.44
Silent Lead 10m	593-130	1+	£23.53	5+	£22.24	10+	£19.62

Right Angled Version

Same as above but the silent connector is right angled.

Description	Code	Price (Ex VAT)					
Right-Angled Silent Lead 5m	593-140	1+	£19.46	5+	£17.87	10+	£15.98
Right-Angled Silent Lead 5m	593-150	1+	£22.93	5+	£21.67	10+	£19.24

Studiospares Cloth Covered Leads

Guitar Leads

A cloth covered Guitar lead has immediate practical advantages, it is very flexible and highly resistant to kinks.

- Looks good and incorporates a low capacity cable which maintains the high frequencies
- The critical centre core which handles the signal is surrounded by a carbon plastic anti static sheath
- A further spirally wound Oxygen Free Copper shield keeps hum inducing magnetic fields at bay
- Heavy plated connectors



Description	Code	Price (Ex VAT)					
5m	590-120	1+	£7.50	10+	£6.75		
10m	590-130	1+	£9.70	10+	£8.75		

Right Angled Guitar Lead

Ideal when high impedance pickups require specialised interconnection.

- 20 strands of 0.12mm OFC copper wire surrounded by a PE dielectric
- Outer jacket is a multi-coloured polypropylene braid surrounded by a thick transparent PVC shield
- Chunky all metal plugs include heatshrink between plug and cable



Description	Code	Price (Ex VAT)					
R-Angled Guitar Lead	588-570	1+	£5.47	10+	£4.92		

WHICH lead do i need?

GUITAR LEADS

Guitar Leads have many requirements that are unlike normal equipment interconnecting leads.

The cable must have low self capacity, an antistatic tube must be under the outer sheath and the screening must be copper wire wound either spirally or braided around the inner insulator.

If you need more information, please contact our technical sales team, who will be glad to help further.

Studiospares Pro Guitar Leads

High quality professional guitar lead!

- Straight Neutrik Black bodied Tribor Gold plated Mono Jack plug one end and either a Gold or Nickel plated Neutrik Right angled Mono Jack plug the other
- Cable is Klotz dual screened "La Grange" Guitar Cable
- Low cable capacitance
- Lapped copper and electrostatic conductive plastic screen



Plug A	Plug B	Length	Code
Nickel R/Angled Jack to a Black Gold straight Jack		5.0m	580-940
Nickel R/Angled Jack to a Black Gold straight Jack		10m	574-960
Gold Black R/Angled Jack to a Black Gold straight Jack		5.0m	593-180
Gold Black R/Angled Jack to a Black Gold straight Jack		10m	593-190
Black bodied Gold plated straight Jack plug both ends		5.0m	593-160
Black bodied Gold plated straight Jack plug both ends		10m	593-170

Description	Code	Price (Ex VAT)					
Nickel 5m	580-940	1+	£14.42	5+	£12.48		
Nickel 10m	574-960	1+	£21.34	10+	£18.59		
R/A Black Gold 5m	593-180	1+	£15.62	5+	£13.96		
R/A Black Gold 10m	593-190	1+	£20.68	5+	£18.92		
Straight Gold 5m	593-160	1+	£15.24	5+	£13.68		
Straight Gold 10m	593-170	1+	£19.96	5+	£18.23		

The Ultimate Guitar Lead

Possibly the ultimate Guitar Lead.

The dedicated cable consists of 20 strands of 0.12mm OFC copper wires surrounded by a PE dielectric which achieves ultra low capacity. This is surrounded by a tube of carbonised conductive PVC to stop static noises occurring when the cable is flexed. The spirally wound copper screen consists of 64 strands of 0.12mm OFC copper. The outer jacket is a multicoloured polypropylene braid surrounded by a thick transparent PVC shield. This saves the attractive braiding from getting soiled and can be easily wiped clean. The all metal plugs have a moulded-in rubber type grip, a really effective spring strain relief and a Gold tipped Jack plug for enhanced reliability. These leads are manufactured to the ISO9001 standard and are imported in container loads hence the highly competitive prices.

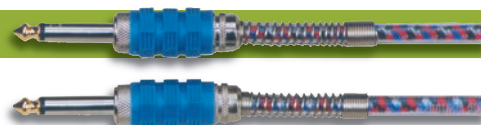

Description	Code	Price (Ex VAT)					
Guitar Lead 5m	588-550	1+	£4.96	10+	£4.46	20+	£3.96
Guitar Lead 10m	588-560	1+	£8.74	10+	£7.87	20+	£6.99

Studiospares Armoured Leads

Shielded High Flexibility Leads

The ultimate in strength, reliability and quality.

- The stainless steel shield is moulded into stoppers located inside the connector
- Even more flexible than conventional plastic jacketed cables
- Internal shield is of spirally wound copper
- The die cast female XLR includes two raised pressure points to ensure the shell remains tight whatever the mating connector



Description	Code	Price (Ex VAT)					
XLR Fe - Straight Jk 5m	588-730	1+	£10.40	10+	£9.35		
XLR Fe - Straight Jk 10m	588-740	1+	£12.80	10+	£12.30		
R/A Jk - Straight Jk 5m	588-620	1+	£9.90	10+	£9.40		
R/A Jk - Straight Jk 10m	588-630	1+	£14.90	10+	£13.40		

Klotz Silent Titanium

Guitar Leads

Klotz, the German cable company whose products are based on quality, not price.

- The Titanium cable is dual screened with a spirally wound copper screen plus a plastic conductive screen
- The connectors are of the Black Neutrik NP2 series with Gold contacts for maximum reliability
- One connector includes a muting switch which turns the cable "on" when the plug is fully inserted



Description	Code	Price (Ex VAT)					
Titanium 3m	514-380	1+	£35.80	5+	£32.60		
Titanium 6m	514-390	1+	£38.50	5+	£35.10		
Titanium 3m R-Angled	514-400	1+	£35.80	5+	£32.60		
Titanium 6m R-Angled	514-410	1+	£38.50	5+	£35.10		

DELIVERY BEFORE NOON no problem

SATURDAY DELIVERY no problem

Klotz La Grange

Pro Guitar Leads

Klotz La Grange cable has always taken number one place in any comparison charts.

- The twisted copper wire screening provides excellent screening against unwanted buzzes and hums whilst remaining flexible
- The plugs are Neutrik and the cable/connector joint is reinforced for maximum reliability



Description	Code	Price (Ex VAT)			
3m	514-110	1+	£28.40	10+	£25.60
6m	514-120	1+	£34.20	10+	£30.80
9m	514-130	1+	£39.60	10+	£35.70

Mogami Guitar Lead 6m

The Mogami 2524 premium guitar cable utilizes a high density shield and conductive PVC layer to eliminate handling noise.

- Oxygen free copper core
- Top quality Neutrik connectors
- Shielding allows pure uncoloured sound
- Straight Mono Jack
- Packaging made from 90% recycled materials



Description	Code	Price (Ex VAT)			
Guitar Lead 6m	501-070	1+	£33.32	5+	£31.65

LEADS

Headphone Extension Leads

Headphone Extension Cable



Professionally manufactured using a Neutrik NP3 and Neutrik NJ3FC6C in line Jack socket on Sommer cable. Cable securely attached to the connectors which in turn have excellent strain reliefs.

Description	Code	Price (Ex VAT)			
5m	593-060	1+	£16.32	10+	£14.34
10m	593-070	1+	£19.92	10+	£17.68
15m	593-410	1+	£22.26	10+	£19.74

Studiospares Neutrik ZX

Pro Guitar Leads

A very high quality lead using Tribor Gold plated Neutrik Mono Jack plugs.

- Neutrik Right angled Mono Jack plug one end and a Tribor Gold plated Neutrik Mono Jack plug the other
- Low cable capacitance
- Lapped copper and electrostatic conductive plastic screen



Description	Code	Price (Ex VAT)			
R/Angled Red 5m	593-560	1+	£12.54	5+	£10.89
R/Angled Blue 5m	593-550	1+	£12.54	5+	£10.89
R/Angled Gold 5m	593-580	1+	£12.54	5+	£10.89
R/Angled Silver 5m	593-570	1+	£12.54	5+	£10.89
R/Angled Black 5m	593-540	1+	£12.54	5+	£10.89
R/Angled Red 10m	593-610	1+	£16.88	5+	£14.92
R/Angled Blue 10m	593-600	1+	£16.88	5+	£14.92
R/Angled Gold 10m	593-630	1+	£16.88	5+	£14.92
R/Angled Silver 10m	593-620	1+	£16.88	5+	£14.92
R/Angled Black 10m	593-590	1+	£16.88	5+	£14.92
Straight Red 5m	593-760	1+	£12.44	5+	£10.73
Straight Blue 5m	593-750	1+	£12.44	5+	£10.73
Straight Gold 5m	593-780	1+	£12.44	5+	£10.73
Straight Silver 5m	593-770	1+	£12.44	5+	£10.73
Straight Black 5m	593-740	1+	£12.44	5+	£10.73
Straight Red 10m	593-810	1+	£16.42	5+	£14.63
Straight Blue 10m	593-800	1+	£16.42	5+	£14.63
Straight Gold 10m	593-830	1+	£16.42	5+	£14.63
Straight Silver 10m	593-820	1+	£16.42	5+	£14.63
Straight Black 10m	593-790	1+	£16.42	5+	£14.63

Hosa Tweed + Cloth Covered Leads

High quality professional guitar lead!

- Features a braided Oxygen Free Copper shield which minimises the chances of buzzes and local taxis breaking through
- Nickel plated connectors for long term reliability
- Aside from 595-880 using one right angled connectors, all other connectors are straight
- All leads 5m length



Tweed Right Angled

Description	Code	Price (Ex VAT)			
Tweed Straight	595-870	1+	£14.90	5+	£13.40
Tweed R/Angled	595-880	1+	£15.60	5+	£13.90
Cloth Black/White/Blk	595-890	1+	£13.40	5+	£11.90
Cloth Black/Green/White	595-900	1+	£13.40	5+	£11.90
Cloth Red/Green Straight	595-910	1+	£13.40	5+	£11.90
Cloth Black/Gold Straight	595-920	1+	£13.40	5+	£11.90
Cloth Black/Red Straight	595-930	1+	£13.40	5+	£11.90

Headphone/Equipment Cable

Moulded Gold Extension Leads

Connectors are Gold plated and the cable is a lapped screen.



Moulded cables are more reliable when the cable to connector joint is put under pressure.

Description	Code	Price (Ex VAT)					
Stereo Jack Moulded 3m	591-330	1+	£4.39	10+	£3.96	30+	£3.53
Stereo Jack Moulded 5m	591-340	1+	£4.85	10+	£4.37	30+	£3.89
Stereo Jack Moulded 10m	591-350	1+	£7.50	10+	£6.75	30+	£5.97
Stereo Jack Moulded 15m	591-360	1+	£11.98	10+	£10.82	30+	£9.62

Description	Code	Price (Ex VAT)					
Mini Jack Moulded 3m	591-490	1+	£3.78	10+	£3.41	30+	£3.04
Mini Jack Moulded 5m	591-500	1+	£4.24	10+	£3.82	30+	£3.40
Mini Jack Moulded 10m	591-510	1+	£5.92	10+	£5.33	30+	£4.74
Mini Jack Moulded 15m	591-520	1+	£9.84	10+	£8.86	30+	£7.88

Beyer DT100/150/250 Headphone Leads

Professionally headphone leads manufactured by Studiospares.

- Using Highly flexible Klotz Cable, a Neutrik NP3 Jack Plug and Beyer's Spin Headphone plug



Description	Code	Price (Ex VAT)			
DT100 Lead 3m	593-280	1+	£17.93	10+	£16.84
DT100 Lead 6m	593-290	1+	£20.78	10+	£19.15
DT100 Lead 10m	593-300	1+	£24.84	10+	£22.61
DT100 Lead 15m	593-310	1+	£28.92	10+	£26.53

Coiled Headphone Lead 6m

Stereo Jack

A coiled headphone cable designed to handle the rigors of the studio.

- Cable molded to the connector for greater reliability
- OK for any impedance headphone
- Nickel plated contacts for long term reliability.
- Colour mid grey



Description	Code	Price (Ex VAT)			
Headphone Lead 6m	597-540	1+	£5.84	5+	£5.55

DELIVERY BEFORE 10AM no problem

Keep up to date with all the latest products and current prices on the new look **Studiospares** website!

Check out www.studiospares.com

LEADS

Armoured Leads

Armour Shielded High Flexibility

The ultimate in strength, reliability and quality.

The stainless steel screening is spirally wound with the ends moulded into a plastic stopper inside the Jack plug. This technique removes any possibility of the screening breaking away from the plug. Of a similar design to the handset leads used in some vandal resistant public telephone boxes. Much more flexible than conventional PVC leads. Underneath the external stainless steel armour is a very high specification two core cable with 20 strands of 0.12mm diameter copper cable. This is within an additional antistatic graphite impregnated tube which stops crackle when the lead is flexed. The spirally wound copper shield consists of 64 strands of 0.12mm diameter copper wire. This is covered in a PVC jacket underneath the armour screen. The Jack plugs are hard chromed and nickel where appropriate. Jacks are unbalanced/mono.



Description	Code	Price (Ex VAT)					
XLR Male - XLR Female 5m	588-600	1+	£12.92	10+	£11.64	20+	£10.34
XLR Male - XLR Female 10m	588-610	1+	£18.80	10+	£16.90	20+	£14.95
XLR Female - Straight Jack 5m	588-730	1+	£10.40	10+	£9.35	20+	£8.30
XLR Female - Straight Jack 10m	588-740	1+	£14.75	10+	£12.75	20+	£11.80

Description	Code	Price (Ex VAT)					
Jack - Jack 1m	588-640	1+	£4.32	10+	£3.90	20+	£3.47
Jack - Jack 2.5m	588-650	1+	£7.92	10+	£7.12	20+	£6.32
Jack - Jack 5m	588-710	1+	£10.40	10+	£9.35	20+	£8.30
Jack - Jack 10m	588-720	1+	£15.60	10+	£14.10	20+	£12.60

Description	Code	Price (Ex VAT)					
Right angle Jack - straight Jack 5m	588-620	1+	£9.90	10+	£9.40	20+	£8.90
Right angle Jack - straight Jack 10m	588-630	1+	£14.90	10+	£13.40	20+	£11.90

Phono Leads

Moulded Dual Stereo Phono Leads

High quality interconnection moulded dual Phono leads. Supplied as a stereo pair.

- Decent low capacity cable minimises high frequency losses
- Genuine lapped copper screening makes this cable ideal for equipment interconnection
- Supplied in five lengths



Description	Code	Price (Ex VAT)			
0.6m	591-530	1+	£3.59	10+	£3.23
1m	591-540	1+	£4.07	10+	£3.65
2.5m	591-550	1+	£4.59	10+	£4.15
5m	591-560	1+	£5.39	10+	£4.86
10m	591-570	1+	£6.56	10+	£5.92

Moulded Phono Leads (Mono)

Moulded for absolute reliability.

- Choice of Phono - Phono or Phono - Jack
- Moulded leads OK for static studio wiring but may resent abuse



Plug A	Plug B	Cable	Length	Code
Moulded Phono	Moulded Jack	L'weight Moulded	0.8m	574-090
Moulded Phono	Moulded Phono	L'weight Moulded	1.0m	591-580
Moulded Phono	Moulded Phono	L'weight Moulded	5.0m	591-590

Description	Code	Price (Ex VAT)			
Moulded Phono-Jk 0.8m	574-090	1+	£4.11	10+	£3.70
Moulded Phono 1m	591-580	1+	£1.57	10+	£1.42
Moulded Phono 5m	591-590	1+	£2.49	10+	£2.24

Professional Dual Phono - Phono Lead

Most Phono Leads are of domestic quality and merely look good.

- This lead still looks good but includes totally industrial components
- Solidly engineered, this precision component includes an eight part gold plated sprung collar
- Sommer Onyx 2025 Mk2 twin cable for it's mechanical strength and spirally wound Oxygen Free Copper screen
- Locally produced this lead should last a lifetime



Description	Code	Price (Ex VAT)			
0.6m	594-030	1+	£8.63	5+	£7.48
1m	594-040	1+	£8.98	5+	£7.86
2.5m	594-050	1+	£10.78	5+	£9.52
5m	594-060	1+	£13.86	5+	£12.22
10m	594-070	1+	£17.55	5+	£15.96
Dual Extension Lead 2.5m	594-080	1+	£11.33	5+	£9.94
Dual Extension Lead 5m	594-090	1+	£14.08	5+	£12.32
Dual Extension Lead 10m	594-100	1+	£19.88	5+	£17.55

Shallow Phono Lead

Short right angled phono plug to conventional straight phono plug.

- Great for situations where little space exists behind equipment
- Stereo with Gold plated contacts
- Length 1.5m



Description	Code	Price (Ex VAT)			
Shallow Phono	595-630	1+	£3.98	10+	£3.54

Phono Leads (Mono)

Highly professional phono leads.

- The professional leads automatically have far lower capacity losses, so high frequencies are not attenuated



Plug A	Plug B	Cable	Length	Code
Precision Phono	Precision Phono	Sommer Session	1.5m	573-020
Precision Phono	Precision Phono	Sommer Session	5.0m	573-030
Precision Phono	Neutrik Mono Jack	Sommer Session	1.5m	573-050
Precision Phono	Neutrik Mono Jack	Sommer Session	5.0m	573-060

Description	Code	Price (Ex VAT)			
Phono 1.5m	573-020	1+	£6.76	3+	£6.30
Phono 5m	573-030	1+	£8.83	3+	£8.38
Phono - Mono Jk 1.5m	573-050	1+	£7.60	3+	£7.13
Phono - Mono Jk 5m	573-060	1+	£10.86	3+	£9.88

LEADS

Bantam Leads

Bantam Leads

A range of professional Bantam to everything leads.

- Switchcraft TT253 Bantam plug going to Neutrik or Precision connectors via Sommer or Klotz Bantam designed cable



Plug A	Plug B	Length	Code
Switchcraft TT253	Precision Phono Plug	5m	574-901
Switchcraft TT253	Neutrik XLR Male	5m	574-831
Switchcraft TT253	Neutrik XLR Female	5m	574-811
Switchcraft TT253	Neutrik Stereo Jack	5m	574-210

Description	Code	Price (Ex VAT)			
Bantam - Phono 5m	574-901	1+	£15.13	10+	£13.93
Bantam - XLR Male 5m	574-831	1+	£14.48	10+	£12.92
Bantam - XLR Female 5m	574-811	1+	£14.67	10+	£13.24
Bantam - Stereo Jk 5m	574-210	1+	£15.76	10+	£14.28

FOR
fax orders
Use our fax number...
020 8450 4390

DID
you know?
At Studiospares we process all incoming orders within a few minutes
If anything is to be added to an earlier order, it will be processed as a NEW order.

VISIT
our trade counter
You'll get friendly advice and immediate access to 8000+ product lines!

LEADS

Mini Jack Leads

Professional Mini Jack Leads

A range of quality moulded Mini Jack to everything leads made in the UK.

- Only the finest components are used
- Includes Neutrik XLRs, Neutrik Jacks, Precision Phono Plugs and Sommer cable



Plug A	Plug B	Length	Code
Pro Mini Jack Plug	Neutrik XLR female Socket	2m	574-100
Pro Mini Jack Plug	Neutrik XLR female Socket	5m	593-220
Pro Mini Jack Plug	Neutrik XLR male Plug	2m	574-110
Pro Mini Jack Plug	Neutrik XLR male Plug	5m	593-230
Pro Mini Jack Plug	2x Mono Neutrik Jack Plugs	2m	573-090
Pro Mini Jack Plug	2x Mono Neutrik Jack Plugs	5m	593-250
Pro Mini Jack Plug	2x Precision Phono Plugs	2m	573-100
Pro Mini Jack Plug	2x Precision Phono Plugs	5m	593-260
Pro Mini Jack Plug	1x Phono Plug	2.5m	574-030
Pro Mini Jack Plug	Stereo Jack Socket	0.2m	594-580
Pro Mini Jack Plug	Stereo Jack Socket	2m	594-590
Pro Micro Jack Plug	Mini Jack Socket	0.2m	594-570

Pro Mini Jack Socket	2x Mono Neutrik Jack Plugs	0.2m	594-470
Pro Mini Jack Socket	2x Mono Neutrik Jack Plugs	2m	594-480
Pro Mini Jack Socket	2x Neutrik XLR male Plugs	0.2m	594-490
Pro Mini Jack Socket	2x Neutrik XLR male Plugs	2m	594-500
Pro Mini Jack Socket	2x Neutrik XLR female Plugs	0.2m	594-510
Pro Mini Jack Socket	2x Neutrik XLR female Plugs	2m	594-520

Description	Code	Price (Ex VAT)
Mini Jk-XLR Fe Skt 2m	574-100	1+ £8.86 10+ £7.81
Mini Jk-XLR Fe Skt 5m	593-220	1+ £10.24 10+ £9.26
Mini Jk-XLR Male 2m	574-110	1+ £7.73 10+ £6.82
Mini Jk-XLR Male 5m	593-230	1+ £9.91 10+ £8.95
Mini Jk-2x Mono Jk 2m	573-090	1+ £12.94 3+ £12.04
Mini Jk-2x Mono Jk 5m	593-250	1+ £16.68 10+ £15.25
Mini Jk-2x Phono 2m	573-100	1+ £9.67 3+ £8.86
Mini Jk-2x Phono 5m	593-260	1+ £11.36 10+ £10.62
Mini Jk-Phono Plug 2.5m	574-030	1+ £7.31 10+ £6.55
Mini Jk-St Jk Skt 0.2m	594-580	1+ £12.33 10+ £11.18
Mini Jk-St Jk Skt 2m	594-590	1+ £13.94 10+ £12.58
Micro Jk-Mini Jk Skt 0.2m	594-570	1+ £8.80 10+ £7.92

Mini Jk Skt-2x Min Jk 0.2m	594-470	1+ £14.17 10+ £12.74
Mini Jk Skt-2x Min Jk 2m	594-480	1+ £14.95 10+ £13.45
Mini Jk Skt-XLR Ma 0.2m	594-490	1+ £13.73 10+ £12.44
Mini Jk Skt-XLR Ma 2m	594-500	1+ £14.96 10+ £13.49
Mini Jk Skt-XLR Fe 0.2m	594-510	1+ £14.68 10+ £13.23
Mini Jk Skt-XLR Fe 2m	594-520	1+ £15.76 10+ £14.22

Professional Right Angled Leads

Mini Jack Leads

A series of UK made professionally assembled Mini Jack leads offering absolute reliability.

- Both ends are Gold plated Right Angle Neutrik NTP3RC which comes with a proper chuck for excellent cable retention
- Cable is Sommer Scuba with a braided copper screen for ultimate screening performance



Description	Code	Price (Ex VAT)
Mini Jk - Mini Jk 0.2m	594-110	1+ £12.19 5+ £10.66
Mini Jk - Mini Jk 1m	594-120	1+ £12.69 5+ £10.98
Mini Jk - Mini Jk 25m	594-130	1+ £13.33 5+ £11.67
Mini Jk - Mini Jk 5m	594-140	1+ £15.25 5+ £13.34
Mini Jk - Stereo Jk 2m	594-150	1+ £16.64 5+ £14.14
Mini Jk - Stereo Jk 5m	594-160	1+ £15.55 5+ £13.51

Studiospares Gold Pro Leads

Moulded Gold Mini Jack Leads

A range of Mini Jack leads to suit every requirement.



The cable uses generous amounts of copper for the conductor and for the lapped copper screen. The Gold plated connectors incorporate effective strain reliefs.

Stereo leads can equally well be used in mono applications.

Description	Code	Price (Ex VAT)
Mini Jack - Mini Jack 0.6m	591-600	1+ £4.16 10+ £3.74 30+ £3.33
Mini Jack - Mini Jack 1m	591-610	1+ £4.38 10+ £3.95 30+ £3.52
Mini Jack - Mini Jack 2.5m	591-620	1+ £5.11 10+ £4.59 30+ £4.09
Mini Jack - Mini Jack 5m	591-630	1+ £5.71 10+ £5.14 30+ £4.57
Mini Jack - Mini Jack 10m	591-640	1+ £7.97 10+ £7.18 30+ £6.39
Mini Jack - Stereo Jack 1m	591-650	1+ £4.36 10+ £3.93 30+ £3.49
Mini Jack - Stereo Jack 2m	591-660	1+ £5.08 10+ £4.57 30+ £4.07
Mini Jack - Stereo Jack 5m	591-670	1+ £6.23 10+ £5.61 30+ £4.99

Klotz Mini Jack Leads

Red/Black Coded Plugs

A truly professional product.

- Features an industrial grade Gold plated minijack plug and Neutrik connectors.



Plug A	Plug B	Length	Code
Mini Jack Plug	2x XLR female plugs	1.0m	514-300
Mini Jack Plug	2x XLR female plugs	3.0m	514-310
Mini Jack Plug	2x XLR male plugs	1.0m	514-340
Mini Jack Plug	2x XLR male plugs	3.0m	514-350
Mini Jack Right-Angled Plug	2x XLR female plugs	1.0m	514-320
Mini Jack Right-Angled Plug	2x XLR female plugs	3.0m	514-330
Mini Jack Right-Angled Plug	2x XLR male plugs	1.0m	514-360
Mini Jack Right-Angled Plug	2x XLR male plugs	3.0m	514-370
Mini Jack Plug	2x Mono Jack Sockets	0.2m	514-010
Mini Jack Plug	2x Phono Sockets	0.2m	514-020

Description	Code	Price (Ex VAT)
Mini Jk-2x XLR Fe 1m	514-300	1+ £19.50 10+ £17.55
Mini Jk-2x XLR Fe 3m	514-310	1+ £28.60 10+ £25.80
Mini Jk-2x XLR Ma 1m	514-340	1+ £24.40 10+ £22.10
Mini Jk-2x XLR Ma 3m	514-350	1+ £28.50 10+ £25.70
R/A Mini Jk-2x XLR Fe 1m	514-320	1+ £26.30 10+ £23.70
R/A Mini Jk-2x XLR Fe 3m	514-330	1+ £31.40 10+ £28.50
R/A Mini Jk-2x XLR Ma 1m	514-360	1+ £24.10 10+ £21.80
R/A Mini Jk-2x XLR Ma 3m	514-370	1+ £28.30 10+ £25.50
Mini Jk-2x Mono Jk 0.2m	514-010	1+ £9.88 10+ £8.89
Mini Jk-2x Phono 0.2m	514-020	1+ £7.44 10+ £6.70

Headphone/Equipment Extension Cable

Moulded Gold Leads

Connectors are Gold plated and the cable is a lapped screen.

- Moulded cables are more reliable when the cable to connector is put under pressure



Description	Code	Price (Ex VAT)
Mini Jack Moulded 3m	591-490	1+ £3.78 10+ £3.41
Mini Jack Moulded 5m	591-500	1+ £4.24 10+ £3.82
Mini Jack Moulded 10m	591-510	1+ £5.92 10+ £5.33
Mini Jack Moulded 15m	591-520	1+ £9.84 10+ £8.86

Mini Jack Leads

A range of quality moulded Mini Jack to everything leads.



Plug A	Plug B	Length	Code
Mini Jack Plug stereo	2x Mono Jacks	1.0m	589-380
Mini Jack Plug stereo	2x Mono Jacks	3.0m	589-370
Mini Jack Plug stereo	2x Phono Plugs	1.0m	580-860
Mini Jack Plug stereo	2x Phono Plugs	3.0m	580-870
Mini Jack Socket stereo	2x Phono Plugs	0.1m	574-820
Mini Jack Plug stereo	2x Mono Jack Sockets	0.1m	574-770
Mini Jack Plug stereo	2x Phono Sockets	0.1m	574-800
Mini Jack Plug stereo	Mini Jack socket Extension	3.0m	595-170
Mini Jack Plug stereo	XLR Male mono	1.5m	582-660
Mini Jack Plug stereo	Mono Jack mono	1.5m	582-670

Description	Code	Price (Ex VAT)
Mini Jk-2x Mono Jk 1m	589-380	1+ £4.28 10+ £3.84
Mini Jk-2x Mono Jk 3m	589-370	1+ £5.39 10+ £4.86
Mini Jk-2x Phono 1m	580-860	1+ £4.16 10+ £3.74
Mini Jk-2x Phono 3m	580-870	1+ £4.98 10+ £4.31
Mini Jk Skt-2x Phono 0.1m	574-820	1+ £3.72 10+ £3.13
Mini Jk-2x Mono Jk Skt 0.1m	574-770	1+ £4.34 10+ £3.81
Mini Jk-2x Phn Skt 0.1m	574-800	1+ £4.34 10+ £3.81
Mini Jk-Mini Jk Ext 3m	595-170	1+ £3.11 3+ £2.77
Mini Jk-XLR Male 1.5m	582-660	1+ £5.56 5+ £5.01
Mini Jk-Mono Jk 1.5m	582-670	1+ £5.56 5+ £5.01

Gold Plated Mini Jack Leads

For situations where only the best is appropriate.

- Self cleaning Gold plated Phono plugs so contact can be assured even if the plug remains connected for years
- The cable is secured firmly to the body of the plug and will not part even under extreme conditions
- Increased distance between the inner conductor and outer screen



Description	Code	Price (Ex VAT)
Mini Jk - Mini Jk 1.5m	597-240	1+ £5.74 10+ £5.17
Mini Jk - Mini Jk 3m	597-250	1+ £7.16 10+ £6.44
Mini Jk - 2x Phono 1.2m	582-090	1+ £4.82 10+ £4.34
Mini Jk - 2x Phono 3m	582-100	1+ £6.76 10+ £6.04
Mini Jk - 2x Phono 5m	582-110	1+ £9.89 10+ £8.89
Mini Jk - 2x Phono 10m	582-120	1+ £9.22 10+ £8.30

LEADS

Mini Jack Leads

CONTINUED

Studiospares Mini Jack Leads

A range of quality moulded Gold Mini Jack to everything leads.



Plug A	Plug B	Length	Code
Mini Jack Plug stereo	2x XLR male plugs	0.2m	591-890
Mini Jack Plug stereo	2x XLR male plugs	3.0m	591-900
Mini Jack Plug stereo	2x Mini Jack Sockets	0.2m	591-910
Mini Jack Plug stereo	2x Jack Sockets	0.2m	591-920
Mini Jack Plug stereo	2x Phono	1m	592-080
Mini Jack Plug stereo	2x Phono	3m	592-090
Mini Jack Plug stereo	2x Mono Jack	2m	592-100
Mini Jack Plug stereo	2x Mono Jack	5m	592-110

Description	Code	Price (Ex VAT)	
Mini Jack-2x XLR Ma 0.2m	591-890	1+	£4.86
Mini Jack-2x XLR Ma 3m	591-900	1+	£7.22
Mini Jk-2x MiniJk Skt 0.2m	591-910	1+	£4.08
Mini Jk-2x Jack Skt 0.2m	591-920	1+	£4.58
Mini Jk-2x Phono 1m	592-080	1+	£4.86
Mini Jk-2x Phono 3m	592-090	1+	£7.22
Mini Jk-2x Mono Jack 2m	592-100	1+	£4.86
Mini Jk-2x Mono Jack 5m	592-110	1+	£8.52

Jack Patch Cords

Europa Moulded Patch Cables

Gold Plated

Moulded for absolute reliability.

- A 64 strand x 0.12mm lapped copper screen ensures excellent flexibility and screening
- Low DC losses are ensured by the use of 20 strands of 0.12mm copper wire
- Length 24inches (600mm)
- Manufactured in accordance with ISO9001



Description	Code	Price (Ex VAT)	
Stereo/Balanced	591-290	1+	£3.44
Mono/Unbalanced	591-370	1+	£3.07

Jack to Jack 1/4inch Type A

Jack to Jack 600mm.

- Standard quarter inch type A plugs
- Metal plugs and Europa cable
- Two versions



Description	Code	Price (Ex VAT)	
Unbalanced/Mono	574-761	1+	£3.91
Balanced/Stereo	574-871	1+	£3.93

Jack to Right Angled Jack Patch Cords

Right Angled Coloured Cords x6

Good quality set of coloured connectors.

- Cable is securely moulded to the connector



Description	Code	Price (Ex VAT)	
6x Stereo 60cm	591-690	1+	£9.84
6x Mono 60cm	591-700	1+	£7.52

MORE PRODUCTS online

Europa Moulded Jack Patch Cords

6 Pack

Set of six colours, Black, White, Blue, Red, Green and Yellow.

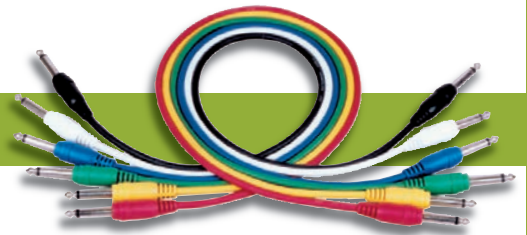

Manufactured from mono Jack plugs moulded to 600mm (24") of 5mm diameter cable with a carbonised PVC shield for reduced handling noise. Copper screen consists of 32 strands of 0.12mm OFC copper. Conductors consist of 20 strands of 0.12mm OFC copper. These leads are manufactured to the ISO9001 standard and are imported by Studiospares in container loads hence the highly competitive prices.

Description	Code	Price (Ex VAT)			
6x Mono Coloured Patch Cords	588-390	1+	£6.47	10+	£5.81
6x Stereo Coloured Patch Cords	589-150	1+	£7.82	10+	£6.99

Europa Moulded Jack Patch Cords

Right Angled Cords x6

Moulded for absolute reliability.

- A 64 strand x 0.12mm lapped copper screen ensures excellent flexibility and screening
- Low DC losses are ensured by the use of 20 strands of 0.12mm copper wire
- Length 24inches (600mm)
- Set of six colours, Black, White, Blue, Red, Green and Yellow
- Manufactured in accordance with ISO9001



Description	Code	Price (Ex VAT)	
6x Mono 0.5m	588-380	1+	£9.31
6x Stereo 0.5m	591-680	1+	£11.24

Professional Short Jack Patch Leads

Designed to allow engineers to easily patch interconnecting leads within a confined area.

- Avoids the problem associated with a lot of equipment concentrated in a confined area
- Two lengths and four colours
- The colour option makes identifying leads easier
- UK hand made with Neutrik Mono and Stereo Jack plugs using Sommer Club and Sommer Tricone cable



Description	Code	Price (Ex VAT)	
Mono 0.1m Black	593-840	1+	£9.43
Mono 0.1m Red	593-842	1+	£9.43
Mono 0.1m Green	593-845	1+	£9.43
Mono 0.1m Blue	593-846	1+	£9.43
Mono 0.3m Black	593-850	1+	£9.62
Mono 0.3m Red	593-852	1+	£9.62
Mono 0.3m Green	593-855	1+	£9.62
Mono 0.3m Blue	593-856	1+	£9.62
Stereo 0.1m Black	593-880	1+	£11.29
Stereo 0.1m Red	593-882	1+	£11.29
Stereo 0.1m Yellow	593-884	1+	£11.29
Stereo 0.1m Green	593-885	1+	£11.29
Stereo 0.1m Blue	593-886	1+	£11.29
Stereo 0.1m Violet	593-887	1+	£11.29
Stereo 0.3m Black	593-890	1+	£11.52
Stereo 0.3m Red	593-892	1+	£11.52
Stereo 0.3m Yellow	593-894	1+	£11.52
Stereo 0.3m Green	593-895	1+	£11.52
Stereo 0.3m Blue	593-896	1+	£11.52
Stereo 0.3m Violet	593-897	1+	£11.52

Diago Patchfactory

Solderless Patch Cable System

Strong, reliable connections and easy assembly to build a flawless cable without tools or knowledge.

- Build custom length patch cables
- No loose parts or additional screws
- Includes a sharp knife to cut cable length
- Enough to produce 10 cables
- Kit includes 3m of cable
- Right Angled Jack Plug - Cut the cable and insert it into the body of the plug and just tighten the cap



Description	Code	Price (Ex VAT)	
Patchfactory	602-680	1+	£53.90
Angled Patch Plug	602-690	1+	£3.90

Rean Patch Cords

Mono Jack Patch Cords

Chunky Rean connectors and a low loss copper screened cable with an added strain relief guarantees reliability.

- Gold plated tips for assured contact
- Mono and stereo versions
- 0.3m version avoids a "rats nest"
- 0.6m version (2 ft) is standard length
- Lapped copper screening



Description	Code	Price (Ex VAT)	
Mono 0.6m	511-580	1+	£3.78
Stereo 0.3m	511-590	1+	£3.87
Stereo 0.6m	511-600	1+	£4.23

Klotz Moulded 900mm Type A Jack

A quality product incorporating the very latest plug and cable technology.

- 900mm of cable and moulded plug assembly for increased reliability
- Based on Klotz Instrument Cable with good screening and low handling noise
- Unbalanced/Mono plugs are of a tough rubbery material to provide great strength
- Pack of five leads, Red, Pink, Blue, Yellow and Green.



Description	Code	Price (Ex VAT)	
Patch Cords x5	573-380	1+	£32.20

LEADS

XLR Patch Cords

XLR Patch Cords

Alleviates the problem of patching between equipment with long leads.

- This range uses Neutrik NC3XLRs and the new Neutrik unisex XLR Convertcon which is really useful due to its flexibility



Description	Code	Price (Ex VAT)			
XLR Ma-XLR Ma 0.1m	594-190	1+	£9.43	3+	£8.66
XLR Ma-XLR Ma 0.3m	594-200	1+	£9.62	3+	£8.86
XLR Fe-XLR Fe 0.1m	594-210	1+	£9.92	3+	£9.24
XLR Fe-XLR Fe 0.3m	594-220	1+	£10.37	3+	£9.44
XLR Convertcon 0.1m	594-230	1+	£19.32	3+	£17.56
XLR Convertcon 0.3m	594-240	1+	£19.60	3+	£17.82

LEADS

Bantam Patch Cords/Leads

Coloured Bantam Patch Cords

Available in 4 colours.

- 24 inch high quality patch cords
- Consist of quad core, twin conductor low noise high conductivity PVC cable
- The shielding is copper wire NOT conductive plastic
- The plugs are of nickel plated brass
- The whole assembly is highly flexible and sealed for absolute protection



Description	Code	Price (Ex VAT)			
Black	574-070	1+	£7.90	2+	£7.70
Red	574-480	1+	£7.90	2+	£7.70
White	574-490	1+	£7.90	2+	£7.70
Green	574-520	1+	£7.90	2+	£7.70

Coloured Moulded Bantam Patch Cords

Set of 6 patch cords manufactured from Gold Plated Bantam TT plugs.

- Moulded to 600mm (24") of 5mm diameter cable
- Copper screen consists of 32 strands of 0.12mm OFC copper
- An additional carbonised conductive plastic shield
- Set of six colours: Black, Mauve, Blue, Red, Green and Yellow



Description	Code	Price (Ex VAT)			
Patch Cords x6	588-400	1+	£16.72	5+	£14.99

Bantam Patch Leads

Useful leads to patch equipment directly into a Bantam Patch Bay.



Description	Code	Price (Ex VAT)			
Bantam-XLR Male 0.9m	596-360	1+	£9.88	10+	£8.91
Bantam-XLR Female 0.9m	596-350	1+	£9.70	10+	£8.73
Bantam-Stereo Jack 0.9m	596-370	1+	£7.82	10+	£7.11
Bantam-Stereo Jack 1.5m	596-380	1+	£8.76	10+	£7.83

Rean Short Patch Cords

Bantam Patch Cords

Rean (Neutrik) Bantam Patch Cords

Incredible value REAN Neutrik Bantam patch cords. Available in 30cm, 60cm, 1.2m and 1.8m options, and in a choice of four colours.



Description	Code	Price (Ex VAT)					
		1+	10+	25+	£2.49		
30cm Black	588-690	1+	£3.32	10+	£2.82	25+	£2.49
30cm Red	581-840	1+	£3.32	10+	£2.82	25+	£2.49
30cm Blue	581-841	1+	£3.32	10+	£2.82	25+	£2.49
30cm Green	581-842	1+	£3.32	10+	£2.82	25+	£2.49
60cm Black	581-850	1+	£3.83	10+	£3.28	25+	£2.87
60cm Red	581-860	1+	£3.83	10+	£3.28	25+	£2.87
60cm Blue	581-861	1+	£3.83	10+	£3.28	25+	£2.87
60cm Green	581-862	1+	£3.83	10+	£3.28	25+	£2.87
1.2m Black	581-870	1+	£4.42	10+	£3.85	25+	£3.44
1.2m Red	581-880	1+	£4.42	10+	£3.85	25+	£3.44
1.2m Blue	581-881	1+	£4.42	10+	£3.85	25+	£3.44
1.2m Green	581-882	1+	£4.42	10+	£3.85	25+	£3.44
1.8m Black	581-890	1+	£5.11	10+	£4.45	25+	£3.99
1.8m Red	581-900	1+	£5.11	10+	£4.45	25+	£3.99
1.8m Blue	581-901	1+	£5.11	10+	£4.45	25+	£3.99
1.8m Green	581-902	1+	£5.11	10	£4.45	25+	£3.99

Neutrik Bantam Star Quad

Bantam Patch Cords

NRA-TT & MAC Bantam 4.4mm (TT) Cables.

- Fully Sealed Bantam (TT) 4.4mm Plugs
- Low Noise
- Star-Quad PVC Cable (Not available on NRA-TT)
- High Conductivity
- Black, Red, Blue and Green



Description	Code	Price (Ex VAT)			
0.3m Black	511-740	1+	£4.94	10+	£4.45
0.3m Green	511-742	1+	£4.94	10+	£4.45
0.3m Red	511-743	1+	£4.94	10+	£4.45
0.45m Black	511-750	1+	£5.19	10+	£4.68
0.6m Black	511-760	1+	£5.51	10+	£4.96
0.6m Blue	511-761	1+	£5.51	10+	£4.96
0.6m Green	511-762	1+	£5.51	10+	£4.96
0.6m Red	511-763	1+	£5.51	10+	£4.96
0.9m Blue	511-771	1+	£6.21	10+	£5.59
0.9m Green	511-772	1+	£6.21	10+	£5.59
1.8m Black	511-780	1+	£8.22	10+	£7.40
1.8m Red	511-783	1+	£8.22	10+	£7.40

Other Patch Cords

Patch Cord Adaptor Cables

A useful selection of short adaptor cables for patching between XLRs, Jacks and MiniJacks

- Decent strain reliefs protect cable when bent round tight radiuses
- Copper screened cable for best results
- MiniJack lead has Gold plated contacts
- XLRs use long established connectors



Description	Code	Price (Ex VAT)			
XLR Fe-Mono Jk 0.15m	597-520	1+	£6.62	5+	£6.32
XLR Ma-Mono Jk Skt 0.15m	597-530	1+	£7.82	5+	£7.43
Mini Jk-Stereo Jk Skt 0.2m	597-550	1+	£4.42	5+	£4.15

Wordclock Leads

Wordclock Leads

Popular wordclock leads with BNC to BNC and BNC to Phono connections.

- BNC-BNC - Made with Neutrik BNCs and Sommer Focusline 75ohm cable
- BNC-PHONO - Made with Neutrik BNCs, Gold Phonos and Sommer Focusline 75ohm cable



Description	Code	Price (Ex VAT)			
BNC-BNC 2m	580-260	1+	£12.92	5+	£11.52
BNC-BNC 5m	579-930	1+	£14.72	5+	£13.15
BNC-PHONO 0.5m	593-080	1+	£7.43	5+	£6.48
BNC-PHONO 2.5m	593-090	1+	£9.74	5+	£8.63
BNC-PHONO 5.0m	579-940	1+	£11.92	5+	£10.86

1000s of products Available from stock!

WANT a job?

Are you looking for a stable and rewarding career?

Studiospares are constantly expanding. We require additional staff for a variety of positions, working in a very congenial atmosphere. Practical experience of recording and/or live sound engineering would be preferable.

send in your CV in the first instance

LEADS

Guitar Pedal Leads

Studiospares Guitar Pedal Leads

UK-made professional quality guitar pedal/stomp box connecting lead.

- Made with Klotz AC110 guitar cable and the new Neutrik NP2RX-B right-angled Jack plugs



Description	Code	Price (Ex VAT)		
15cm	593-200	1+	£11.34	5+ £10.21
25cm	593-210	1+	£12.08	5+ £10.85

Hosa Low Profile Guitar Patch Leads

Low profile plugs using Oxygen Free Cable.



Description	Code	Price (Ex VAT)		
R/ Angle - R/ Angle 0.15m	595-970	1+	£4.99	5+ £4.59
R/ Angle - R/ Angle 0.3m	595-980	1+	£5.62	5+ £5.09
R/ Angle - R/ Angle 0.45m	595-990	1+	£5.99	5+ £5.46

Hosa Guitar Pedal Leads

A general purpose interconnecting lead designed to live beneath musicians feet.

- Good quality nickel plated connectors



Description	Code	Price (Ex VAT)		
R/ Angle - R/ Angle 0.15m	595-940	1+	£7.48	5+ £6.76
R/ Angle - R/ Angle 0.3m	595-950	1+	£6.18	5+ £5.58
R/ Angle - R/ Angle 0.45m	595-960	1+	£6.68	5+ £5.95

LEADS

Digital Leads

Digital Transfer Leads (SPDIF)

Featuring 75Ω coaxial cable and high quality Gold plated Phono plugs.

- Connects between the digital outputs of DAT recorders, samplers etc
- They are an exact impedance match to avoid standing waves and signal corruption



Description	Code	Price (Ex VAT)		
1m	579-540	1+	£6.19	5+ £5.49
3m	579-550	1+	£8.78	5+ £7.89
5m	579-950	1+	£9.98	5+ £8.79
10m	579-960	1+	£12.81	5+ £11.64

Cat 5e Digital Cables

Cat 5e leads which include Neutrik Shells (Carriers) and cable with 0.5mm diameter conductors.

- Two types, one or two metal cased locking carriers (shells)
- The Carrier is a Neutrik lockable metal shell into which an RJ45 moulded connector is fitted

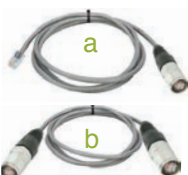

Description	Code	Price (Ex VAT)		
RJ45 - RJ45 inc shell 5m	590-580	1+	£7.20	5+ £6.48
RJ45 - RJ45 inc shell 10m	590-590	1+	£9.20	5+ £8.28
RJ45 inc shell both ends 5m	590-600	1+	£10.80	5+ £9.72
RJ45 inc shell both ends 10m	590-610	1+	£12.80	5+ £11.52

AES/EBU Leads

A range of dedicated AES/EBU Leads.

- Using Neutrik Digital XLRs and Sommer Binary AES/EBU 110 ohm cable



Description	Code	Price (Ex VAT)		
1m	580-020	1+	£17.92	5+ £16.35
3m	580-030	1+	£19.82	5+ £17.75
5m	580-040	1+	£22.32	5+ £20.58

Y/Splitter Leads

Klotz Splitter Leads

Red/Black

A truly professional product.

- Features an industrial grade Gold plated minijack plug and/or Neutrik connectors



Plug A	Plug B	Length	Code
Mini Jack Right-Angled Plug	2x Mono Jack Sockets	1.0m	514-260
Mini Jack Right-Angled Plug	2x Mono Jack Sockets	3.0m	514-270
Mini Jack Right-Angled Plug	2x Phono Sockets	1.0m	514-280
Mini Jack Right-Angled Plug	2x Phono Sockets	3.0m	514-290
Stereo Jack Plug	2x Mono Jack Sockets	0.2m	514-000
Stereo Jack Socket	2x Mono Jack Plugs	0.2m	514-030
Mini Jack Socket	2x Phono Plugs	0.2m	514-040
Mono Jack Plug	2x Mono Jack Sockets	0.2m	514-050
Mono Jack Plug	2x Phono Sockets	0.2m	514-060

Description	Code	Price (Ex VAT)		
Mini Jk-2x MJ Skt 1m	514-260	1+	£9.24	10+ £8.32
Mini Jk-2x MJ Skt 3m	514-270	1+	£11.46	10+ £10.32
Mini Jk-2x Phono Skt 1m	514-280	1+	£9.63	10+ £8.67
Mini Jk-2x Phono Skt 3m	514-290	1+	£11.94	10+ £10.75
Stereo Jk-2x MJ Skt 0.2m	514-000	1+	£9.32	10+ £8.37
SJ Skt-2x Mono Plug 0.2m	514-030	1+	£8.56	10+ £7.71
Mini Jk-2x Phono 0.2m	514-040	1+	£7.66	10+ £6.90
Mono Jk-2x MJ Skt 0.2m	514-050	1+	£9.32	10+ £8.39
Mono Jk-2x Phono 0.2m	514-060	1+	£7.44	10+ £6.70

Professional XLR Y Leads

These Y leads are based on Neutrik XX series connectors.

- Splits one output into two
- The cabling is balanced throughout using Sommer Scuba
- The 0.1m lengths provide more convenience
- 1m and 2.0m versions save additional plugs and sockets in the signal chain
- Hand made to a very high specification

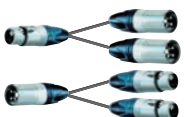

Description	Code	Price (Ex VAT)		
XLR male-2 XLR fem 0.1m	593-420	1+	£11.98	10+ £10.66
XLR male-2 XLR fem 2m	593-520	1+	£14.98	10+ £13.57
XLR fem-2 XLR male 0.1m	593-430	1+	£11.73	10+ £10.57
XLR fem-2 XLR male 2m	593-530	1+	£14.72	10+ £13.39

Moulded Y Leads

A useful range of leads primarily intended to be substituted for adaptors which may be sited at the rear of the equipment.

- Make replugging simple
- Eliminate sideways or downward pull of the lead which would damage the equipment, particularly Phonos and Mini Jacks

Plug A	Plug B	Length	Code
Mono Jack Socket	2x Mono Jack Plugs	0.2m	591-880
Stereo Jack Socket	2x Stereo Jack Plugs	0.1m	595-360
Stereo Jack Socket	2x Phono Plugs	0.1m	595-370
Stereo Jack Socket	2x Mono Jack Plugs	0.2m	591-830
Stereo Jack Socket	2x Stereo Jack Plugs	0.2m	591-840
Phono Socket	2x Phono Plugs	0.1m	574-850
Phono Plug	2x Phono Sockets	0.1m	574-840
Mono Jack Plug	2x Mono Jack Plugs	1.0m	595-300
Mono Jack Plug	2x Phono Plugs	0.1m	574-890
Mono Jack Plug	2x Phono Plugs	2.0m	589-670
Mono Jack Plug	2x Phono Sockets	0.1m	574-990
Mono Jack Plug	2x Mono Jack Sockets	0.2m	591-870
Stereo Jack Plug	2x Stereo Jack Plugs	1.0m	595-310
Stereo Mini Jack Plug	2x XLR Male (Y lead)	2.0m	580-900
Stereo Mini Jack Plug	2x XLR Male (Y lead)	3.0m	595-290
Stereo Mini Jack Plug	2x Mini Jack Sockets	0.1m	574-750
Stereo Mini Jack Plug	2x 1/4" Stereo Jack Scks	0.1m	574-560
Mini Jack Socket	2x R/ Angled Mini Jack Scks	2.0m	597-440
Right Angle Mini Jk plug	2x XLR fem (unbalanced)	1.5m	595-330
Stereo Jack Plug	2x Mini Jack Sockets	0.2m	591-810
Stereo Jack Plug	2x Mono Jack Sockets	0.2m	591-790
Stereo Jack Plug	2x Stereo Jack Plugs	0.2m	591-800
Stereo Jack Plug	2x Stereo Jack Sockets	0.2m	591-820
Stereo Jack Plug	2x XLR Male	1.2m	597-390
Stereo Jack Plug	2x XLR Female	1.2m	597-400
Stereo Jack Plug	2x Mini Jack sockets	0.1m	574-780
Stereo Jack Plug	2x Jack sockets	0.1m	574-670
XLR Male	2x XLR Female	0.1m	595-340
XLR Female	2x XLR Male	0.1m	595-350

Description	Code	Price (Ex VAT)		
MJ Skt - 2 Mono Jk 0.2m	591-880	1+	£4.46	10+ £4.02
St Jk Skt - 2 Phono 0.1m	595-360	1+	£4.67	5+ £4.23
St Jk Skt - 2 St Jk 0.1m	595-370	1+	£3.55	10+ £3.14
St Jk Skt - 2 Mono Jk 0.2m	591-830	1+	£4.46	10+ £4.02
St Jk Skt - 2 St Jk 0.2m	591-840	1+	£4.74	10+ £4.27
Phono Skt - 2 Phono 0.1m	574-850	1+	£2.67	10+ £2.34
Phono - 2 Phono Jk 0.1m	574-840	1+	£2.67	10+ £2.34
Mono Jk - 2 Mono Jk 1m	595-300	1+	£4.92	10+ £4.44
Mono Jk - 2 Phono 0.1m	574-890	1+	£3.28	10+ £2.85
Mono Jk - 2 Phono 2m	589-670	1+	£2.20	10+ £2.09
Mono Jk - 2 Ph Skt 0.1m	574-990	1+	£3.28	10+ £2.83
Mono Jk - 2 MJ Skt 0.2m	591-870	1+	£3.84	10+ £3.46
St Jk - 2 St Jk 1m	595-310	1+	£5.77	10+ £5.21
St MJ - 2 XLR Ma 2m	580-900	1+	£9.76	10+ £8.80
St MJ - 2 XLR Ma 3m	595-290	1+	£12.25	10+ £11.10
St MJ - 2 MJ Skt 0.1m	574-750	1+	£4.34	10+ £3.81
St MJ - 2 St Jk Skt 0.1m	574-560	1+	£4.76	10+ £4.11
MJ Skt - 2 R/A Mjk Skt 2m	597-440	1+	£2.24	5+ £2.02
R/A Mjk - 2 XLR Fem 1.5m	595-330	1+	£9.82	10+ £8.87
St Jk - 2 Mini Jk Skt 0.2m	591-810	1+	£4.56	10+ £4.11
St Jk - 2 Mono Jk Skt 0.2m	591-790	1+	£4.24	10+ £3.82
St Jk - 2 St Jk 0.2m	591-800	1+	£4.24	10+ £3.82
St Jk - 2 St Jk Skt 0.2m	591-820	1+	£4.92	10+ £4.53
St Jk - 2 XLR Ma 1.2m	597-390	1+	£7.38	5+ £6.63
St Jk - 2 XLR Fem 1.2m	597-400	1+	£7.38	5+ £6.63
St Jk - 2 Mjk Skt 0.1m	574-780	1+	£4.41	10+ £3.92
St Jk - 2 Jk Skt 0.1m	574-670	1+	£4.36	10+ £3.83
XLR Ma - 2 XLR Fem 0.1m	595-340	1+	£9.36	10+ £8.42
XLR Fem - 2 XLR Ma 0.1m	595-350	1+	£9.22	10+ £8.29

FOR
fax orders
 Use our fax number...
020 8450 4390

Studiospares Moulded Splitter Leads

High quality general purpose moulded splitter leads.

- Splitting monojack plug to 2 x monojack plugs
- Choice of 1m, 2m, or 4m
- Moulded for greater reliability
- Excellent value for money



Description	Code	Price (Ex VAT)
MonoJack-2 MonoJack 1m	592-050	1+ £4.48 10+ £4.04
MonoJack-2 MonoJack 2m	592-060	1+ £4.96 10+ £4.47
MonoJack-2 MonoJack 4m	592-070	1+ £6.84 10+ £6.16

Insert Leads

LEADS

Moulded Insert Leads

A comprehensive range of insert leads to interface equipment send and returns to effects units.

- These Insert leads are used for splitting the differing signals from the RING and TIP of Stereo Plugs
- All leads are moulded and have excellent contact materials for trouble free operation
- The leads split the ring and tip and can also be used for equipment interfaces



Splitting to	Details	Length	Code
Stereo Jack Plug	1x XLR male + 1x XLR fem (tip send/ring return)	2.0m	591-970
Stereo Jack Plug	1x XLR male + 1x XLR fem (tip send/ring return)	4.0m	591-980
Stereo Jack Plug	2x Mono 1/4" Jack Plugs	1.0m	591-990
Stereo Jack Plug	2x Mono 1/4" Jack Plugs	2.0m	592-000
Stereo Jack Plug	2x Mono 1/4" Jack Plugs	4.0m	592-010
Stereo Jack Plug	2x Mono 1/4" Jack Skts	0.1m	574-600
Stereo Jack Plug	2x Phono Plugs	2.0m	592-020
Stereo Jack Plug	2x Phono Plugs	4.0m	595-210
Stereo Jack Plug	2x Phono Sockets	0.1m	579-010
Stereo Jack Plug	1x Mono Jack socket	0.1m	595-250
Stereo Jack plug	links send and return and taps signal from link to the Jack socket.		
Stereo Jack Socket	2x Mono 1/4" Jack Plugs	0.1m	574-740
Mini Jack Plug	2x Mono 1/4" Jack Sockets	0.1m	574-770
Mini Jack Plug	2x Phono Sockets	0.1m	574-800
Right Angle Mini Jack	2x Phono Sockets	0.1m	595-220
Mini Jack Socket	2x Phono Plugs	0.1m	574-820

Description	Code	Price (Ex VAT)
St Jk - 2 XLR 2m	591-970	1+ £8.44 10+ £7.60
St Jk - 2 XLR 4m	591-980	1+ £9.44 10+ £8.50
St Jk - 2 Mono Jk 1m	591-990	1+ £4.68 10+ £4.24
St Jk - 2 Mono Jk 2m	592-000	1+ £5.21 5+ £4.69
St Jk - 2 Mono Jk 4m	592-010	1+ £7.18 10+ £6.46
St Jk - 2 Mono Jk Skt 0.1m	574-600	1+ £4.34 10+ £3.81
St Jk - 2 Phono 2m	592-020	1+ £4.96 10+ £4.47
St Jk - 2 Phono 4m	595-210	1+ £8.14 10+ £7.42
St Jk - 2 Phono Skt 0.1m	579-010	1+ £3.45 5+ £2.98
St Jk - 2 MonoJk Skt 0.1m	595-250	1+ £6.42 10+ £5.78
St Jk Skt - 2 Mono Jk 0.1m	574-740	1+ £4.13 10+ £3.53
MiniJk - 2 MonoJk Skt 0.1m	574-770	1+ £4.34 10+ £3.81
MiniJk - 2 Phono Skt 0.1m	574-800	1+ £4.34 10+ £3.81
R/A Mjk - 2 Phono Skt 0.1m	595-220	1+ £3.92 10+ £3.54
MiniJk Skt - 2 Phono 0.1m	574-820	1+ £3.72 10+ £3.13

Professional Insert Leads

All split from a Neutrik Stereo Jack Plug.

- These professional Insert Leads use Neutrik connectors, Sommer Isopod cable and expandable sleeving
- XLR versions wired in both possible configurations



Splitting to	Details	Length	Code
2x Mono Jacks	Tip to Send or Ret - Ring to Send or Return	2.5m	580-050
2x Mono Jacks	Tip to Send or Ret - Ring to Send or Return	5.0m	573-070
2x Mono Jacks	Tip to Send or Ret - Ring to Send or Return	10m	593-320
XLR Male & XLR Female	Tip Send male XLR - Ring Return female XLR	2.5m	580-060
XLR Male & XLR Female	Tip Send male XLR - Ring Return female XLR	5.0m	573-550
XLR Male & XLR Female	Ring Send male XLR - Tip Return female XLR	2.5m	580-070
XLR Male & XLR Female	Ring Send male XLR - Tip Return female XLR	5.0m	573-080

Description	Code	Price (Ex VAT)
St Jk - 2 Mono Jk 2.5m	580-050	1+ £18.68 5+ £16.59
St Jk - 2 Mono Jk 5m	573-070	1+ £15.98 10+ £14.09
St Jk - 2 Mono Jk 10m	593-320	1+ £19.42 10+ £17.31
XLR Ma - XLR Fe 2.5m TS	580-060	1+ £18.38 5+ £16.38
XLR Ma - XLR Fe 5m TS	573-550	1+ £21.42 10+ £19.23
XLR Ma - XLR Fe 2.5m RS	580-070	1+ £18.75 5+ £16.87
XLR Ma - XLR Fe 5m RS	573-080	1+ £17.86 10+ £15.81

DMX Leads

LEADS

DMX Lead XLR Male - XLR Female

For DMX-control or master/slave connection.

- 3-pin XLR plug to 3-pin XLR socket
- Accurate, noise free control
- Cable 4.0mm



Description	Code	Price (Ex VAT)
1.5m	582-560	1+ £4.60 5+ £4.14
3m	582-570	1+ £6.20 5+ £5.58
6m	582-580	1+ £8.40 5+ £7.56
10m	582-590	1+ £9.90 5+ £8.90
20m	582-600	1+ £14.70 5+ £13.23

iPhone/iPad/iPod Leads

LEADS

iPod Splitter Lead

iPOD Splitter Lead allows iPod and iPod mini users to share and enjoy their music.

- It has 24k Gold plated connectors for optimum signal transfer
- Can be daisy chained for multiple users without loss of quality
- Its shielded, dual twisted pair conductors give excellent audio quality



Description	Code	Price (Ex VAT)
iPod Splitter Lead	475-980	1+ £4.90 2+ £4.40

iPod Recording + Monitoring Lead

A unique cable enabling users to interface a microphone and XLR equipment outputs.

- Professionally manufactured in the UK
- Neutrik XLRs
- Hi Grade 4 pole Mini Jack
- 1x XLR mic input + 2x XLR line out



Description	Code	Price (Ex VAT)
Mini Jack - XLR 0.2m	594-720	1+ £19.80 5+ £17.90
Mini Jack - XLR 2m	594-730	1+ £23.70 5+ £21.80

iK iLine

Mobile Music Cable Kit

The ultimate hook-up cable kit.

- Complete collection of six high-quality audio cables (with a convenient travel case)
- Designed for pure audiophile sound
- Made from high-quality components including 24k gold-plated connectors
- High-purity copper conductors, high-density shielding and low-capacitance insulation
- Cables included in the iLine Mobile Music Cable Kit below



NEW LOWER PRICE

Application	Details	Length	Code
Mono Output Adapter	1/8" (3.5mm) stereo male to 1/4" (6.35mm) mono female	30cm	321-620
Input Output Extension	1/8" (3.5mm) TRRS male to 1/8" (3.5mm) TRRS female	60cm	321-630
Stereo Aux	1/8" (3.5mm) stereo male to 1/8" (3.5mm) stereo male	150cm	321-640
Headphone Splitter	1/8" (3.5mm) stereo male to 2 x 1/8" (3.5mm) stereo fem	30cm	321-660
RCA Output Adapter	1/8" (3.5mm) stereo male to 2 x RCA mono male	150cm	321-610
Mono Output Splitter	1/8" (3.5mm) stereo male to 2 x 1/4" (6.35mm) mono fem	60cm	321-650

Description	Code	Price (Ex VAT)
Mobile Music Cable Kit	321-670	1+ £33.30 2+ £32.90
Mono Output Adapter	321-620	1+ £10.65 2+ £10.25
Input Output Extension	321-630	1+ £10.65 2+ £10.25
Stereo Aux	321-640	1+ £10.65 2+ £10.25
Headphone Splitter	321-660	1+ £9.99 2+ £9.16
RCA Output Adapter	321-610	1+ £13.30 2+ £12.90
Mono Output Splitter	321-650	1+ £10.65 2+ £10.25

Rode SC2

iPhone-iXY Minijack TRS Cable

A high-quality shielded 3.5mm TRS patch cable.

- Extends from 170mm to up to 400mm
- Right-angle connectors for ergonomic use
- Connects the output of an Apple iPhone to other equipment



Description	Code	Price (Ex VAT)
SC2	497-150	1+ £9.16 2+ £8.50

PRICE match

Studiospares will BEAT any genuine price from any UK competitor on any item or order.

details on page 318

DELIVERY BEFORE NOON
no problem

MORE PRODUCTS
online

iPhone/iPad/iPod Leads

LEADS

CONTINUED

Rode SC6

Smartphone - 2x SmartLav TRRS Kit

A input/output breakout box for smartphones and tablets.

- Two TRRS inputs and one stereo headphone output
- Connects to any TRRS device
- Can use one or two smartLav mics and headphones
- Monitor audio from the smartLav
- Note that the two mic inputs will be recorded to the same channel



Description	Code	Price (Ex VAT)			
SC6	497-160	1+	£10.82	2+	£10.24

Rode SC7

TRS 3.5mm-TRRS Patch Cable

Designed to allow the VideoMic GO to connect to TRRS compatible devices such as the iPhone or iPad.

- Gold plated contacts are colour coded
- Grey indicates the TRRS output
- Cable is colour matched to the red TRS to TRS cable that is supplied with the VideoMic GO



Description	Code	Price (Ex VAT)			
SC7	497-270	1+	£9.16	2+	£8.70

Speaker Leads

LEADS

4 Pole Speakon Leads For Bi-Amping

With Neutrik Plugs

Sommer Elephant 4x 2.5mm cable.

- For Bi-Amping consists of 1x 4 pole Neutrik Speakon NL4FX splitting to 2x Neutrik Speakon NL2FC.



Lead	Length	Code
1x 4 pole Speakon - 2x 2 pole Speakons	5m	593-950
1x 4 pole Speakon - 2x 2 pole Speakons	10m	593-960
1x 4 pole Speakon - 2x 2 pole Speakons	25m	593-970

Description	Code	Price (Ex VAT)			
5m	593-950	1+	£24.95	5+	£22.75
10m	593-960	1+	£41.50	5+	£37.50
25m	593-970	1+	£59.80	5+	£55.20

4 Pole Professional Speakon Leads

With Neutrik Plugs

No compromises on quality.

- Manufactured locally from 4 pole Neutrik Speakons NL4FX and Sommer Elephant 4x 2.5mm cable



Lead	Length	Code
4 pole Speakon - Speakon	5m	593-920
4 pole Speakon - Speakon	10m	593-930
4 pole Speakon - Speakon	25m	593-940

Description	Code	Price (Ex VAT)			
4 Pole Speakon 5m	593-920	1+	£29.90	5+	£26.75
4 Pole Speakon 10m	593-930	1+	£41.50	5+	£37.50
4 Pole Speakon 25m	593-940	1+	£75.25	5+	£67.77

Professional Speaker Leads

A quality product designed to last a lifetime.

These leads are designed for the rigours of the road whilst being equally suited to fixed installations. The cable is tough Europa Speaker Cable using 4mm, 2.5mm or 1.5mm conductors for maximum efficiency. (See table). Speaklocs mate with any twist to lock speaker plug. These leads will provide a long trouble free life even under arduous conditions. Manufactured in accordance with the ISO9001 standard.

Plug A	Plug B	Wire dia	Length	Code	Price (Ex VAT)			
		2.5	0.5m	594-680	1+	£8.67	5+	£7.82
		4.0	5m	588-890	1+	£13.80	5+	£13.20
		4.0	10m	588-900	1+	£22.30	5+	£20.30
Speakloc 4 pin	Speakloc 4 pin	4.0	25m	588-910	1+	£43.90	3+	£41.80

Plug A	Plug B	Wire dia	Length	Code	Price (Ex VAT)			
		2.5	5m	588-920	1+	£17.30	5+	£15.60
		2.5	10m	588-930	1+	£26.50	3+	£24.80
Speakloc 8 pin	Speakloc 8 pin	2.5	25m	588-940	1+	£49.70	3+	£47.40

Plug A	Plug B	Wire dia	Length	Code	Price (Ex VAT)			
		1.5	5m	588-410	1+	£6.96	10+	£6.26
		1.5	10m	588-420	1+	£9.91	5+	£8.92
High Current Jack	High Current Jack	1.5	25m	588-430	1+	£15.35	5+	£14.35

Plug A	Plug B	Wire dia	Length	Code	Price (Ex VAT)			
		2.5	0.5m	594-690	1+	£6.18	5+	£5.29
		2.5	5m	588-800	1+	£5.78	5+	£5.12
		2.5	10m	588-810	1+	£7.45	5+	£6.68
Speakloc 4 pin	Bare wires	2.5	25m	588-820	1+	£15.30	5+	£13.75

Plug A	Plug B	Wire dia	Length	Code	Price (Ex VAT)			
		2.5	5m	588-830	1+	£6.92	5+	£6.32
		2.5	10m	588-840	1+	£11.65	5+	£10.55

Plug A	Plug B	Wire dia	Length	Code	Price (Ex VAT)			
		2.5	5m	588-860	1+	£8.61	5+	£8.40
		2.5	10m	588-870	1+	£14.90	5+	£13.40
		2.5	25m	588-880	1+	£19.90	5+	£17.90

Plug A	Plug B	Wire dia	Length	Code	Price (Ex VAT)			
		2.5	5m	588-440	1+	£7.92	10+	£7.13
		2.5	10m	588-450	1+	£11.63	5+	£10.52
		2.5	25m	588-460	1+	£17.86	5+	£16.10

Plug A	Plug B	Wire dia	Length	Code	Price (Ex VAT)			
		2.5	5m	590-550	1+	£7.48	10+	£6.71
		2.5	10m	590-560	1+	£10.82	5+	£9.64
		2.5	25m	590-570	1+	£18.22	5+	£16.46

PDF catalogue

Want this catalogue on your phone or laptop?

The Studiospares catalogue is now available in PDF format.

visit www.studiospares.com/page/pdfcatalogue/

PRICE changes

This catalogue was priced on 1st December 2014.

Current prices may be higher...

see our website for up to date prices.

Killer Watt Speaker Leads

Killer Watt Speaker Leads use the finest materials available and are constructed to last and last.

They are happy to live under stage paraphernalia and musicians' feet. Cable conductors are properly terminated and the jacket firmly gripped. All versions use 2.5mm Sommer Meridian Speaker Cable for the lowest DC losses. (Most others use cheaper 1.5mm). The plugs are either Neutrik Jacks, Neutrik Speakons or Gold Plated 4mm stackable Banana Plugs. Jack plug leads use the new Neutrik NYS225 high current speaker Jack. (Detailed in the Plugs pages). 23 versions as follows:

Plug A	Plug B	Wire dia	Length	Code	Price (Ex VAT)			
		2.5	1m	593-980	1+	£14.96	5+	£13.15
		2.5	2.5m	593-990	1+	£17.29	5+	£15.16
		2.5	5m	580-110	1+	£21.25	5+	£18.60
		2.5	10m	580-120	1+	£26.91	5+	£23.32
		2.5	15m	580-130	1+	£33.33	5+	£xx.xx
		2.5	25m	580-160	1+	£42.24	5+	£37.62
		2.5	50m	594-000	1+	£75.25	4+	£67.77
2.5	75m	594-010	1+	£96.50	4+	£88.90		
Speakon	Speakon	2.5	100m	594-020	1+	£129.50	4+	£123.09

Plug A	Plug B	Wire dia	Length	Code	Price (Ex VAT)			
		2.5	5m	580-170	1+	£15.68	5+	£13.92
		2.5	10m	580-180	1+	£20.30	5+	£18.20
Speakon	4mm Gold Banana	2.5	25m	580-190	1+	£35.64	5+	£33.40

Plug A	Plug B	Wire dia	Length	Code	Price (Ex VAT)			
		2.5	1m	594-270	1+	£10.68	3+	£9.33
		2.5	5m	580-330	1+	£16.92	3+	£14.95
		2.5	10m	580-340	1+	£22.96	3+	£20.76
		2.5	25m	580-350	1+	£36.60	3+	£34.50
Speakon	High Current Jack	2.5	50m	594-280	1+	£64.13	4+	£57.64

Plug A	Plug B	Wire dia	Length	Code	Price (Ex VAT)			
		2.5	1m	594-250	1+	£8.09	3+	£7.05
		2.5	5m	580-910	1+	£14.36	3+	£12.82
		2.5	10m	580-920	1+	£19.77	3+	£17.93
		2.5	25m	580-930	1+	£32.89	3+	£29.70
High Current Jack	High Current Jack	2.5	50m	594-260	1+	£59.62	4+	£53.68

WANT a job?

Are you looking for a stable and rewarding career?

Studiospares are constantly expanding. We require additional staff for a variety of positions, working in a very congenial atmosphere. Practical experience of recording and/or live sound engineering would be preferable.

send in your CV in the first instance

Klotz Speakon 0.3m

Adaptor Lead

A really useful series of leads for anyone involved in PA

- Neutrik Speakons, XLRs and Jacks throughout
- Klotz cable quality
- Length 0.3m



Description	Code	Price (Ex VAT)			
Speakon-XLR Male	514-070	1+	£15.35	10+	£13.88
Speakon-XLR Female	514-080	1+	£16.40	10+	£14.76
Speakon-Monojack Skt	514-090	1+	£15.65	10+	£14.09
Speakon-Stereojack Skt	514-100	1+	£18.75	10+	£16.60

1000s of products Available from stock!

MORE PRODUCTS online

LEADS Camera Leads

Camera Lead

For connecting audio signals into a video camera. Neutrik connectors throughout.

- Neutrik female XLR.
- Rean (Neutrik) Gold Mini Jack plug
- Sommer cable for good screening
- Professionally made in the UK



Description	Code	Price (Ex VAT)			
Mini Jack - XLR Fem 1m	594-700	1+	£8.56	10+	£7.70
Mini Jack - XLR Fem 3m	594-710	1+	£9.81	10+	£8.72

LEADS MIDI Leads

PRO MIDI Leads (Only 3 Pins Wired)

Practically all MIDI leads are DIN leads which have all 5 pins wired.

- Dedicated MIDI leads only wire pins 2, 4 and 5 to maintain data integrity
- These leads use metal Plugs and Sommer Club Oxygen Free Cable



Description	Code	Price (Ex VAT)			
1.2m	579-970	1+	£8.75	5+	£7.70
3m	579-980	1+	£10.34	5+	£9.10
5m	579-990	1+	£12.10	5+	£10.65

Alesis USB MIDI Cable

MIDI To USB Cable

The missing link between MIDI instruments and your computer.

- The USB MIDI Cable makes it easy to connect any MIDI instrument to your Mac or PC via USB
- The AudioLink Series USB cable receives and outputs MIDI signal thanks to its internal interface
- The USB-MIDI Cable connects plug-and-play to your Mac or PC



Description	Code	Price (Ex VAT)			
USB MIDI Cable	385-570	1+	£20.82	2+	£19.90

Right Angled MIDI Leads

Right angled plugs are also favoured on equipment mounted vertically, not horizontally.

- Depth behind the connector panel may be limited and less strain will be exerted on the combined plug/socket if the cable is pulled sideways



Description	Code	Price (Ex VAT)			
R/A MIDI Lead 3m	573-370	1+	£5.19	10+	£4.56

THE website

Keep up to date with all the latest products and current prices on the Studiospares website!

check out www.studiospares.com

MIDI Leads

LEADS

CONTINUED

Moulded Gold MIDI Leads

Probably the finest MIDI Leads currently available.

Moulded construction ensures the cable remains secured to the plug. The low loss cable ensures data integrity even over extended lengths. 3m and 5m leads available in Red and Blue options.



Description	Code	Price (Ex VAT)					
0.5m	591-710	1+	£2.96	10+	£2.67	25+	£2.37
1.2m	591-720	1+	£3.69	10+	£3.32	25+	£2.95
3.0m	591-730	1+	£4.69	10+	£4.23	25+	£3.77
5.0m	591-740	1+	£5.96	10+	£5.38	25+	£4.79
10m	591-750	1+	£9.08	10+	£8.19	25+	£7.30
15m	591-760	1+	£10.40	10+	£9.36	25+	£8.32
20m	591-770	1+	£12.50	10+	£11.34	25+	£10.19
Red 3.0m	591-732	1+	£4.69	10+	£4.23	25+	£3.77
Red 5.0m	591-742	1+	£5.96	10+	£5.38	25+	£4.79
Blue 3.0m	591-736	1+	£4.69	10+	£4.23	25+	£3.77
Blue 5.0m	591-746	1+	£5.96	10+	£5.38	25+	£4.79
Curly Lead Extends to 8m	573-360	1+	£8.75	10+	£7.72	25+	£6.78

Sommer Cat 7

Black leads terminating with Hirose RJ45 connectors.

- All leads protected with Neutrik EtherCon NEBMC1 shells, except 594-770, 594-780 and 594-790



Description	Code	Price (Ex VAT)			
0.5m RJ45/NEBMC1	594-740	1+	£27.50	10+	£24.75
0.5m RJ45/RJ45	594-770	1+	£20.50	10+	£18.50
1.0m RJ45/NEBMC1	594-750	1+	£28.90	10+	£26.00
1.0m RJ45/RJ45	594-780	1+	£22.20	10+	£19.95
3.0m RJ45/NEBMC1	594-760	1+	£34.40	10+	£30.95
5.0m RJ45/NEBMC1	547-260	1+	£37.50	5+	£35.50
10m RJ45/NEBMC1	547-270	1+	£49.90	5+	£47.90
10m RJ45/RJ45	594-790	1+	£47.50	5+	£43.50
30m Drum RJ45/NEBMC1	547-280	1+	£165.00	2+	£155.00
50m Drum RJ45/NEBMC1	547-240	1+	£207.50	2+	£197.50
70m Drum RJ45/NEBMC1	547-250	1+	£274.00	2+	£259.00

USB 3.0 A - MicroB 2m

Computer Lead

Super Speed USB 3.0 cable which has 'A' plug to micro'B' plug connectors.

- Length: 2M
- Quality connectors which will last a lifetime
- Excellent cable retention and flexible strain relief
- Backward compatible



NEW

Description	Code	Price (Ex VAT)			
USB 3.0 A - MicroB 2m	597-740	1+	£6.50	10+	£5.85

USB Guitar Link Cable Interface

Simply plug in your guitar and turn your PC or Mac Computer in to a guitar amp or recording system.

- Stereo Headphone output for headphones or speaker amplifier input
- Works directly with PC or Mac
- Ultra-Low latency driver for PC included
- High-quality components and rugged construction
- Easy Plug and Play Installation
- Variable-speed file playback for MP3, WAV, AIFF audio files



NEW

Description	Code	Price (Ex VAT)			
Guitar Link Cable Interface	602-980	1+	£12.49	2+	£11.95

Optical Leads

LEADS

Optical Lead Thick Moulded

A durable moulded patch cable with a 5mm cable for general purpose patching of optical signals.

- Connectors are Toslink compatible
- Inner cable construction is fluoropolymer-clad PMMA with a polyethylene secondary jacket and PVC outer sheath
- Finish is satin Black



Description	Code	Price (Ex VAT)			
0.6m	585-600	1+	£9.95	5+	£8.95
1m	585-610	1+	£11.95	5+	£10.95
2m	585-620	1+	£13.60	5+	£12.70
5m	585-630	1+	£17.80	3+	£16.30
10m	585-640	1+	£25.70	3+	£23.50

LEADS

Cat 5e/6/7 Computer/Network Leads

Cat 5E

Computer leads with a non tangle catch.

- Conform to the ISO11801 Cat5 1999 and EIA/TIA 568 Addendum 11 draft standards
- Colour Grey
- 1m and 5m also available in Black, Red, Yellow, Green, Blue and Purple



Description	Code	Price (Ex VAT)			
0.5m Grey	517-001	1+	£0.96	5+	£0.86
1.0m Grey	517-011	1+	£1.08	5+	£0.97
1.0m Red	517-012	1+	£1.08	5+	£0.97
1.0m Yellow	517-014	1+	£1.08	5+	£0.97
1.0m Green	517-015	1+	£1.08	5+	£0.97
1.0m Blue	517-016	1+	£1.08	5+	£0.97
1.0m Purple	517-017	1+	£1.08	5+	£0.97
1.5m Grey	517-021	1+	£1.24	5+	£1.12
2.0m Grey	517-031	1+	£1.42	5+	£1.28
3.0m Grey	517-041	1+	£1.64	5+	£1.48
5.0m Grey	517-051	1+	£1.85	5+	£1.66
5.0m Red	517-052	1+	£1.85	5+	£1.66
5.0m Yellow	517-054	1+	£1.85	5+	£1.66
5.0m Green	517-055	1+	£1.85	5+	£1.66
5.0m Blue	517-056	1+	£1.85	5+	£1.66
10.0m Grey	517-061	1+	£3.09	5+	£2.78
15.0m Grey	517-071	1+	£4.35	5+	£3.91
20.0m Grey	517-081	1+	£5.40	5+	£4.86

Cat 6 Extension Cable on a Drum

Neutrik Connectors

Backward compatible to Cat 5e and Cat 5

- Neutrik connectors on the drum and cable.
- Maximum data rate 100Mbit/s
- Cable outer diameter 6mm
- Pin out TIA/EIA 568-B



Description	Code	Price (Ex VAT)
50 metres Cat 6 on a drum	590-620	£68.30
75 metres Cat 6 on a drum	590-630	£74.95
100 metres Cat 6 on a drum	590-640	£82.50

Cat 5e Digital Cables

Cat 5e leads which include Neutrik Shells (Carriers) and cable with 0.5mm diameter conductors.

- Two types, one or two metal cased locking carriers (shells)
- The Carrier is a Neutrik lockable metal shell into which an RJ45 moulded connector is fitted

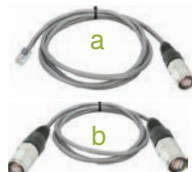

Description	Code	Price (Ex VAT)			
RJ45 - RJ45 inc shell 5m	590-580	1+	£7.20	5+	£6.48
RJ45 - RJ45 inc shell 10m	590-590	1+	£9.20	5+	£8.28
RJ45 inc shell both ends 5m	590-600	1+	£10.80	5+	£9.72
RJ45 inc shell both ends 10m	590-610	1+	£12.80	5+	£11.52

RGB Premium VGA 15PIN

Premium VGA 15 pin to Premium VGA 15 pin.

- 3m lead



Description	Code	Price (Ex VAT)			
VGA 15 pin - VGA 15 pin	580-830	1+	£17.90	3+	£16.70

DELIVERY BEFORE NOON
no problem

Optical Lead Deluxe

A high quality patch cord with a 5mm cable and heavy-duty connectors.



The connectors have a solid metal shell with an attractive haematite finish. The optical centre contact features a spring-loaded mechanism to ensure good contact between the mating optical surfaces, helping to minimise insertion loss.

Description	Code	Price (Ex VAT)					
		1+	5+	10+	15+	20+	25+
0.6m	585-700	£11.80	£10.70	£10.70	£10.70	£8.95	£8.95
1m	585-710	£14.60	£12.75	£12.75	£12.75	£10.95	£10.95
2m	585-720	£19.50	£18.53	£18.53	£18.53	£17.55	£17.55
5m	585-730	£25.00	£24.13	£24.13	£24.13	£22.50	£22.50
10m	585-740	£29.60	£26.80	£26.80	£26.80	£24.20	£24.20

Optical Lead Moulded Thin

Ideal where small size is an advantage and the greater protection offered by the heavier types is not required.

- A lightweight moulded cable with a 2.2mm cable and moulded connectors
- Optimised for a 650nm wavelength
- Attenuation less than 0.15dB per metre
- Inner fibre 1x 1.0mm diameter
- Do not bend this cable round any radius less than 17mm. Otherwise it will become useless.



Description	Code	Price (Ex VAT)			
		1+	5+	10+	25+
0.6m	585-500	£5.80	£5.80	£5.22	£5.22
1m	585-510	£6.40	£6.40	£5.76	£5.76
2m	585-520	£8.35	£8.35	£7.29	£7.29
5m	585-530	£9.95	£9.95	£8.80	£8.80
10m	585-540	£18.50	£18.50	£17.85	£17.85

LEADS Firewire Leads

Firewire Leads 9 pin

FireWire 800 cables include "Beta" and "Bilingual" versions.

- "Beta" refers to cables with 1394b 9 pin connectors on both ends
- "Bilingual" refers to cables used to connect FireWire 800 to FireWire 400
- 9 pin connector on one end and a standard 6 or 4 pin on the other



Description	Code	Price (Ex VAT)			
9 pin - 4 pin 3m	595-000	£19.70	£19.70	£18.70	£18.70
9 pin - 6 pin 3m	595-010	£19.70	£19.70	£18.70	£18.70
9 pin - 9 pin 3m	595-020	£26.50	£26.50	£24.50	£24.50

Firewire Leads/Cables

4/6 Pin

Serial high performance buss to network storage systems, digital audio, computer peripherals etc.

- Leads are hot swappable
- Cable meets IEEE 1394 standard
- Supports high speed data transmissions of 400Mbits/sec



4 pin Firewire



6 pin Firewire

Description	Code	Price (Ex VAT)			
4 pin - 4 pin 1.8m	437-620	£9.42	£9.42	£8.38	£8.38
4 pin - 4 pin 3m	580-650	£6.85	£6.85	£6.15	£6.15
4 pin - 6 pin 1.8m	437-630	£9.73	£9.73	£8.67	£8.67
4 pin - 6 pin 3m	580-660	£6.85	£6.85	£6.15	£6.15
4 pin - 6 pin 5m	595-460	£7.85	£7.85	£7.45	£7.45
6 pin - 6 pin 1m	590-300	£2.98	£2.98	£2.88	£2.88
6 pin - 6 pin 3m	590-310	£4.47	£4.47	£4.32	£4.32
6 pin - 6 pin 5m	595-470	£8.25	£8.25	£7.75	£7.75
6 pin - 4 pin 1m	590-320	£2.86	£2.86	£2.76	£2.76
6 pin - 4 pin 3m	590-330	£4.35	£4.35	£4.22	£4.22

LEADS MADI Optical Leads

MADI Optical Leads

Optical lead with a dual mode (50.125µm) fibre.

- Secondary protection 900µm
- Tension element (arimid) and outward sheathed from LSZH or PVC
- Maximum tension power (N) 350N
- Pressure resistivity 200Ncm
- Beat resistivity 20(w/1N-m)



Duplex 3m

Description	Code	Price (Ex VAT)			
Simplex 1m	597-200	£9.90	£9.90	£9.40	£9.40
Duplex 3m	597-210	£14.20	£14.20	£13.70	£13.70
Duplex 10m	597-220	£24.50	£24.50	£23.50	£23.50
Duplex 50m	597-230	£64.50	£64.50	£62.30	£62.30

LEADS USB Leads

USB A Plug - USB Mini Plug 5 pin

1.8m SB A to USB Mini Plug camera connecting cable.

- Good shielding preventing interference
- 5 pin USB Mini Plug
- Cable moulded into plugs for strength
- Length 1.8m



Description	Code	Price (Ex VAT)			
USB A - 5 pin Mini USB	255-990	£3.29	£3.29	£2.99	£2.99

Studiospares USB Leads

Quality moulded USB leads.

- The most common type of connection for modern PC connections
- Connect a wide range of devices including printers and keyboards
- With USB 2.0 data speeds up to 480Mbps
- Designed to allow full speed connections with error-free transmission
- Will also work with older USB 1.1 and 1.0 equipment



USB A 6 pin plug



USB A 6 pin socket



USB A 4 pin plug

Description	Code	Price (Ex VAT)			
USB-A - 6 pin Plug - 1m	590-240	£1.43	£1.43	£1.27	£1.27
USB-A - 6 pin Plug - 3m	590-250	£1.98	£1.98	£1.78	£1.78
USB-A - 6 pin Socket - 1m	590-260	£1.55	£1.55	£1.40	£1.40
USB-A - 6 pin Socket - 3m	590-270	£2.55	£2.55	£2.19	£2.19
USB-A - 4 pin Plug - 1m	590-280	£1.78	£1.78	£1.61	£1.61
USB-A - 4 pin Plug - 3m	590-290	£2.82	£2.82	£2.54	£2.54

USB 3.0 Superspeed

A range of SuperSpeed 3.0 USB leads allowing fast data transfers from most USB devices such as external hard drives, cameras etc.

- Suitable for speeds up to 5Gbps
- Fully shielded for error-free connections
- Solid construction



Type A



Type B

Description	Code	Price (Ex VAT)			
1.5m A-A	582-610	£4.72	£4.72	£4.25	£4.25
1.5m A-B	582-630	£4.72	£4.72	£4.25	£4.25

FREE
catalogue
Are you reading someone else's catalogue?
Why not call us and order your own copy...
it's free!

PRICE
match
Studiospares will BEAT any genuine price from
any UK competitor on any item or order.
details on page 318

LEADS
USB Interface Leads

Studiospares iLink-2

iPhone/iPad/iPod Interface

Audio interface for iOS devices.

- Use with any of the audio software available on the Apple App Store
- 1/4-Inch jack socket for input of any instrument or line-level signal
- 1/8-Inch output socket for connection of headphones of speakers



Description	Code	Price (Ex VAT)		
iLink-2	449-310	1+	£19.60	10+ £18.30

LEADS
Video Leads

HDMI Cable

To connect an HDTV source with HDMI output to an AV receiver.



Description	Code	Price (Ex VAT)		
4.5m (HDMI 1.3 Cat 2)	596-530	1+	£29.70	10+ £26.80

HDMI - DVI-Dmale Cable

GSP quality HDMI to DVI lead.

- DVI-D to HDMI Lead (GSP).
- For connecting HDMI compliant equipment such as a DVD player to a DVI monitor.
- Featuring gold plated connectors and ferrite cores



Description	Code	Price (Ex VAT)		
HDMI - DVI-Dmale 1m	597-700	1+	£4.15	10+ £3.75
HDMI - DVI-Dmale 5m	597-710	1+	£6.95	10+ £6.25

HDMI High Speed Cable

Premium High Speed + Ethernet HDMI 1080P compliant lead.

- High Definition Multimedia Interface leads with gold plated male to male HDMI connectors.
- Triple screened cable
- Robust cable retention
- Good strain relief to avoid cable breakage through flexing



Description	Code	Price (Ex VAT)		
HDMI High Speed 1m	597-720	1+	£3.32	10+ £2.99
HDMI High Speed 5m	597-730	1+	£4.90	10+ £4.41

LEADS
Insert Looms

8 Way Insert Looms

Jack - Jack

Each channel has a Neutrik Stereo Jack one end and 2x Neutrik NP2 Jack plugs the other end.



- Two lengths

Jack - Monojack (Not Neutrik)

8 channels, each with Stereo Jack one end and 2x Monojacks the other end.

- 3m length

Jack - XLR (Tip = Receive, Ring = Send)

A Neutrik Stereo Jack plug one end and one male and one female XLR the other end.

- There are two wiring configurations, the first is now the most popular and wired such that the Jack's tip is wired to the female XLR used for return signals and the ring on the Jack plug is used to send the signal to the XLR male

Jack - XLR (Tip = Send, Ring = Receive)

A Neutrik Stereo Jack plug one end and one male and one female XLR the other end.

- There are two wiring configurations, the first is now the most popular and wired such that the Jack's tip is wired to the female XLR used for return signals and the ring on the Jack plug is used to send the signal to the XLR male

Description	Code	Price (Ex VAT)		
Jack-Jack 1.5m	580-080	1+	£99.50	2+ £95.70
Jack-Jack 3m	580-090	1+	£129.50	2+ £122.50
Jack-MonoJack 3m	582-480	1+	£47.80	2+ £44.80
Jack-XLR Tip Send 2.5m	580-230	1+	£116.60	2+ £107.20
Jack-XLR Tip Send 5m	580-100	1+	£129.50	2+ £122.50
Jack-XLR Tip Receive 2.5m	580-140	1+	£114.30	2+ £106.60
Jack-XLR Tip Receive 5m	580-150	1+	£132.50	2+ £121.70

Budget Insert Looms

4 Way

Features Hosa's moulded terminations for outstanding performance and durability.

- STP-800 Series Multi Channel insert (send / return) snakes
- Connectors colour coded for easy identification



Description	Code	Price (Ex VAT)		
4x StJk - 8x MonoJk 2m	595-260	1+	£32.80	5+ £29.90
4x StJk - 8x MonoJk 4m	595-270	1+	£39.70	5+ £36.80
4x StJk - 8x Phono 4m	595-280	1+	£38.40	5+ £35.40

LEADS
Wiring Looms

8 Way Pro Balanced Looms

XLR and JACK

These Studiospares professional wiring looms are manufactured to the highest standards.

- The cable is Sommer Mistral jacketed with doublescreening and individual channel numbering
- Neutrik XLRs and NP3C Jack plugs
- The +1m suffix after the length denotes the additional 2x 500mm tails each end
- Cables may be tailored to customised lengths for £20 + the cost of additional length of cable (Code 546-320)
- Tailoring Fee code number 400-200



Description	Code	Price (Ex VAT)		
XLR-XLR 1.5m+1m	579-840	1+	£78.80	2+ £74.60
XLR-XLR 3m+1m	579-850	1+	£86.30	2+ £79.50
XLR-XLR 5m+1m	579-860	1+	£95.80	2+ £88.20
XLR-Jack 1.5m+1m	579-870	1+	£79.40	2+ £74.60
XLR-Jack 3m+1m	579-880	1+	£88.60	2+ £81.40
XLR-Jack 5m+1m	579-890	1+	£97.30	2+ £88.80
Jack-Jack 1.5m+1m	579-900	1+	£87.40	2+ £81.20
Jack-Jack 3m+1m	579-910	1+	£92.40	2+ £84.60
Jack-Jack 5m+1m	579-920	1+	£99.70	2+ £92.50
8 pair Jacketed	546-320	1+	£4.38	20+ £3.91
Tailoring Fee	400-200	1+	£20.00	

Klotz Wiring Looms

8-Way Balanced I/O Multikink

A series of looms manufactured in Germany from Klotz.

- The cable is Klotz Polywire which is ultra flexible
- Conductors have a cross sectional area of 0.22mm²
- The insulator provides a low capacity so high frequencies are not attenuated
- Plugs are Neutrik NC3XX series, Jacks Neutrik NP3C/BAG
- Cables are identified by labelling on the individual pairs



Plug A	Plug B	Length	Code
4x XLR Ma + 4x XLR Fem	4x XLR Fem + 4x XLR Ma	3m	514-450
4x XLR Ma + 4x XLR Fem	4x XLR Fem + 4x XLR Ma	6m	514-460
XLR Female	Jack	3m	514-470
XLR Female	Jack	6m	514-480
XLR Male	Jack	3m	514-490
XLR Male	Jack	6m	514-500
Jack	Jack	3m	514-510
Jack	Jack	6m	514-520

Description	Code	Price (Ex VAT)		
XLR-XLR 3m	514-450	1+	£139.00	2+ £129.00
XLR-XLR 6m	514-460	1+	£154.00	2+ £144.00
XLR Fem-Jack 3m	514-470	1+	£144.00	2+ £134.00
XLR Fem-Jack 6m	514-480	1+	£159.00	2+ £149.00
XLR Male-Jack 3m	514-490	1+	£149.00	2+ £144.00
XLR Male-Jack 6m	514-500	1+	£159.00	2+ £149.00
Jack-Jack 3m	514-510	1+	£149.00	2+ £139.00
Jack-Jack 6m	514-520	1+	£164.00	2+ £154.00

Check out more Studiospares great offers and end-of-line products at our store on...

MORE PRODUCTS online

Studiospares 8/16 Way Looms

Includes both balanced and unbalanced versions.

A range of popular configurations based on very high quality connectors which are colour coded (or occasionally numbered) at both ends. Jack plugs and XLRs use a spring strain relief. The cable uses the more expensive spirally wound copper screening. Heatshrink is used to reduce strain wherever appropriate. Manufactured to the ISO9001 standard.



8 Way

Plug A	Plug B	Length	Balanced/Unbalanced	Code	Price (Ex VAT)		
XLR Male	XLR Female	2.5m	Balanced	589-090	1+	£18.32	2+ £16.40
XLR Male	XLR Female	5m	Balanced	588-230	1+	£29.90	2+ £25.40
XLR Male	Jack	2.5m	Unbalanced	589-680	1+	£19.70	2+ £17.70
XLR Male	Jack	5m	Unbalanced	589-700	1+	£24.00	2+ £22.40
XLR Male	Jack	2.5m	Balanced	589-100	1+	£24.90	2+ £21.40
XLR Male	Jack	5m	Balanced	588-240	1+	£29.90	2+ £25.40
XLR Female	Jack	2.5m	Unbalanced	589-690	1+	£19.70	2+ £17.70
XLR Female	Jack	5m	Unbalanced	589-710	1+	£24.00	2+ £22.40
XLR Female	Jack	2.5m	Balanced	589-110	1+	£24.90	2+ £21.40
XLR Female	Jack	5m	Balanced	588-250	1+	£29.90	2+ £25.40
Jack Plug	Jack Plug	2.5m	Unbalanced	589-660	1+	£22.40	2+ £19.70
Jack Plug	Jack Plug	5m	Unbalanced	589-720	1+	£27.30	2+ £23.50
Jack Plug	Jack Plug	2.5m	Balanced	589-120	1+	£22.30	2+ £19.20
Jack Plug	Jack Plug	5m	Balanced	588-260	1+	£27.30	2+ £23.50

16 Way

Plug A	Plug B	Length	Balanced/Unbalanced	Code	Price (Ex VAT)		
XLR Male	XLR Female	5m	Balanced	589-800	1+	£46.30	2+ £39.40
XLR Male	XLR Female	10m	Balanced	589-810	1+	£62.20	2+ £52.90
Jack Plug	Jack Plug	5m	Balanced	589-820	1+	£39.20	2+ £33.50
Jack Plug	Jack Plug	10m	Balanced	589-830	1+	£43.73	2+ £37.20
Jack Plug	Jack Plug	20m	Balanced	589-840	1+	£57.90	2+ £49.95
XLR Male	Jack	5m	Balanced	589-850	1+	£33.30	2+ £28.20
XLR Male	Jack	10m	Balanced	589-860	1+	£44.85	2+ £38.03
XLR Female	Jack	5m	Balanced	589-870	1+	£33.30	2+ £28.20
XLR Female	Jack	10m	Balanced	589-880	1+	£44.85	2+ £38.03

WANT a job?

Are you looking for a stable and rewarding career?

Studiospares are constantly expanding. We require additional staff for a variety of positions, working in a very congenial atmosphere. Practical experience of recording and/or live sound engineering would be preferable.

send in your CV in the first instance

Wiring Looms 8 Way

Manufactured to the highest standard.

- Cable is Klotz/Europa Monocore with enhanced screening properties and individual channel numbering
- Jack plugs are Neutrik and Phonos are Metal Precision
- Studiospares regret that we are unable to tailor these looms to individual requirements



Description	Code	Price (Ex VAT)		
Phono - Mono Jack 1.5+1	573-150	1+	£52.20	2+ £46.55
Phono - Mono Jack 3m	573-160	1+	£54.40	2+ £48.70
Phono - Mono Jack 5m	573-170	1+	£59.90	2+ £53.60
Jack - Mono Jack 1+1.5m	573-410	1+	£59.90	3+ £53.60
Jack - Mono Jack 1+3m	573-420	1+	£65.30	3+ £59.80
Jack - Mono Jack 1+5m	573-430	1+	£73.70	3+ £66.40

Budget Looms

8 Way

Very reliable and simplifies wiring.

- A range of Budget Looms with plastic plugs either end
- Moulded to individually coloured cables for clear channel identification
- Two lengths, 3m and 7m
- Three configurations, Phono to Phono, Phono to Jack and Jack to Jack
- Very reliable and simplifies wiring



Description	Code	Price (Ex VAT)		
Phono - Phono 3m	573-440	1+	£20.90	3+ £18.90
Phono - Jack 3m	591-780	1+	£14.82	3+ £13.38
Phono - Jack 5m	573-470	1+	£39.80	3+ £37.20
Jack - Jack 3m	573-480	1+	£20.82	3+ £19.45
Jack - Jack 7m	573-490	1+	£33.32	3+ £31.80

DELIVERY BEFORE NOON no problem

ALL PRICES EXCLUSIVE OF VAT.

LOOMS

D Type Looms

Hosa Loom 8 WAY DB25 - 8 XLR/Jacks

Balanced cables with 0.13mm² conductors for low DC losses.

- Oxygen Free Cable with a spirally wound copper shield plus aluminium foil
- Moulded connectors



Description	Code	Price (Ex VAT)		
DB25 - 8xXLR Female 3m	596-150	1+	£39.70	2+ £35.70
DB25 - 8xXLR Female 7m	596-160	1+	£58.40	2+ £53.40
DB25 - 8xXLR Male 3m	596-190	1+	£38.20	2+ £34.40
DB25 - 8xXLR Male 7m	596-200	1+	£54.60	2+ £49.40
DB25 - 8x Stereo Jack 2m	596-170	1+	£34.20	2+ £31.20
DB25 - 8x Stereo Jack 4m	573-510	1+	£49.70	2+ £45.60
DB25 - 8x Stereo Jack 7m	596-180	1+	£62.30	2+ £56.30
D SUB Screws (USA)	596-220	1+	£1.99	5+ £1.79
D SUB Screws (Metric)	596-230	1+	£1.99	5+ £1.79

Hosa DSUB Looms

Balanced cables with 0.13mm² conductors for low DC losses.

- Oxygen Free Cable with a spirally wound copper shield plus aluminium foil
- Moulded connectors



Description	Code	Price (Ex VAT)		
DB25 - DB25 0.4m	596-110	1+	£11.40	2+ £10.20
DB25 - DB25 0.9m	596-120	1+	£13.60	2+ £12.40
DB25 - DB25 1.5m	596-130	1+	£18.20	2+ £16.40
DB25 - DB25 3.0m	596-135	1+	£25.70	2+ £23.20
DB25 - DB25 4.5m	596-140	1+	£32.50	2+ £29.50

DIGITAL AES/EBU Looms

Moulded connectors using 0.13mm² OFC conductors.

- Spirally wound copper shield with added aluminium foil
- Moulded connectors



Loom	Code
Loom AES/EBU DB25 - DB25 Tascam pinout 1.5m	596-450
Loom AES/EBU DB25 - DB25 Tascam pinout 4.5m	596-460
Loom AES/EBU DB25 - 4x XLR Ma/4x XLR Fem Tascam pinout 5m	596-470

Description	Code	Price (Ex VAT)		
DB25 - DB25 1.5m	596-450	1+	£15.70	2+ £14.10
DB25 - DB25 4.5m	596-460	1+	£32.40	2+ £29.20
DB25 - XLR 5m	596-470	1+	£58.80	2+ £53.20

SNAKES

Snakes

Frequently Asked Questions about...

Snakes

Q What are Snakes used for?

A Snakes are typically used where many sound sources, eg vocalists and musicians, are in one place, and the main mixing desk is some distance away.

When recording this could be the studio and the control room, while in live situations the front-of-house mixer is generally a long way from the stage. The snake has a stage box (at the stage end!) and tails at the other end which connect to the mixing desk. Sound signals are passed both ways.

Q What are the input connectors?

A The Input connections are mainly 3pin Female chassis mount XLRs, which require a 3pin XLR Male mic cable connector.

Q What are the return connectors?

A The Returns can be supplied in one of two options: Option 1: 3pin Male XLR Chassis Mount connections; Option 2: Balanced Stereo 1/4inch Jack Socket connections.

Q What are the returns for?

A Returns are used for sending signals back to the stage or studio via the stage box. In other words for sending signal from the Mixing Console to the stage area via stage box returns.

-The main audio signal sent via the returns is the Main Speakers L/R in a live PA environment.

-The other audio signals usually sent back to the stage area via the stage box are the Monitor returns, also known as foldback, the stage speakers used for the musicians.

12 Way Snakes

A range of Cable Snakes which are well made and designed for considerate on the road use or within a studio environment.

- The junction between the box and multicore is protected by a heavy duty flexible cable gland
- Both the cable plugs and the chassis XLR's within the box are of all metal construction
- The multicore is designed to be flexed because it uses spirally wound copper screening



Description	Code	Price (Ex VAT)		
12 Way 1m	589-910	1+	£23.70	2+ £22.20
12 Way 3m	589-920	1+	£39.20	2+ £33.50
12 Way 10m	589-930	1+	£63.50	2+ £53.80
12 Way 20m	589-940	1+	£84.60	2+ £73.50
12 Way 30m	589-950	1+	£97.30	2+ £85.60

Pro Snakes 8, 16 + 24 Way

A comprehensive range of Cable Snakes for patching Microphones, DI boxes, Synths etc. to a distant mixer.



- Included are returns for foldback which can be used as additional inputs to the mixer
- The system is balanced throughout but all or part can equally be used unbalanced
- Neutrik XLRs and Jack plugs are used throughout
- The cable is foil screened
- Sommer cable, UK made

Special Lengths. We are able to supply this snake tailored to any length by payment of a £20 flat "tailoring" fee (order Code 400-200) per loom plus the cost of the additional cable required. Delivery time 5 working days.

For 8+4 way versions additional cable part number is 546-330 per metre. For 16+8 way versions additional cable part number is 546-350 per metre. For 24 way versions additional cable part number is 546-360 per metre.

Description	Code	Price (Ex VAT)		
8x XLR + 4x Jack 3m	571-350	1+	£132.50	2+ £119.70
8x XLR + 4x Jack 6m	571-010	1+	£149.00	2+ £134.00
8x XLR + 4x Jack 12m	571-020	1+	£189.00	2+ £170.00
8x XLR + 4x Jack 25m	571-030	1+	£239.00	2+ £219.00
16x XLR + 8x Jack 3m	571-360	1+	£209.00	2+ £189.60
16x XLR + 8x Jack 6m	571-040	1+	£235.00	2+ £214.00
16x XLR + 8x Jack 12m	571-050	1+	£289.00	2+ £260.00
16x XLR + 8x Jack 25m	571-060	1+	£368.00	2+ £344.00
24x XLR + 24x Jack 6m	571-310	1+	£235.00	2+ £219.00
16x XLR + 24x Jack 12m	571-320	1+	£269.00	2+ £249.00
16x XLR + 24x Jack 25m	571-330	1+	£347.00	2+ £329.00
Tailoring Fee	400-200	1+	£20.00	
8 + 4 Way Cable	546-330	1+	£6.44	20+ £5.73
16 + 8 Way Cable	546-350	1+	£12.46	20+ £11.06
24 Way Cable	546-360	1+	£15.90	20+ £14.31

Europa 8 Way Snakes



This range of Cable Snakes are well made and designed for considerate on the road use or within a studio environment. The junction between the box and multicore is protected by a heavy duty flexible cable gland. Both the cable plugs and the chassis XLR's within the box are of all metal construction, not cheap plastic versions. The plugs are labelled with the appropriate channel numbers. The multicore is designed to be flexed because it uses spirally wound copper screening, not foil screening which can fail if repeatedly flexed in the same position.

Description	Code	Price (Ex VAT)		
8 way 5m	588-660	1+	£55.20	2+ £44.70
8 way 10m	588-670	1+	£63.30	2+ £49.90
8 way 30m	588-680	1+	£79.60	2+ £63.80

4 Way Multicore Drum

4 channels of balanced screened multicore cable on a 15m drum.

- Lapped copper screening for good flexibility and RF rejection
- Connectors provide excellent cable retention to withstand the rigors of the road. Wire mesh cable protection
- Makes setting up and taking down much quicker and provides protection



Description	Code	Price (Ex VAT)		
4x Channel Multicore	590-650	1+	£52.50	2+ £47.50

1000s of products Available from stock!

VISIT our trade counter You'll get friendly advice and immediate access to 8000+ product lines!

Studiospares Europa Snakes



Choice of 8, 12, 16 and 24 XLR inputs...

This product is designed for the worst case scenario, it may have to exist under musicians feet. The case consists of a dark grey two part box of steel 1.5mm thick. This provides mechanical protection and excellent electromagnetic screening. The case includes a full width handle. Sockets are recessed to minimise exposure to damage and cable entry is via a heavy duty nylon/plastic strain relief and gland. (As stock is replenished the gland will be replaced with a metal version including a wire mesh strain relief. The tails will also pass through a wire mesh used to stop straining the cable/plug entry point).

The multicore is a premium grade product using the more expensive spirally wound copper screening. All plugs and sockets are metal with a chrome finish. The flying plugs are clearly numbered for easy identification, even under poor lighting conditions. (Colour coded plugs are difficult to distinguish in poor lighting conditions). Very high quality plugs and sockets are used throughout. Heatshrink is used to protect any cable part exposed to stress.

Supplied in a cardboard box, not a polythene bag! Two versions which differ in the type of plugs used for the returns. Manufactured to the ISO9001 standard and imported in container loads by Studiospares, hence the very competitive prices.

XLR Returns

Inputs	Returns	Length	Code	Price (Ex VAT)		
8x XLR	4x XLR	8m	588-950	1+	£75.80	2+ £64.90
8x XLR	4x XLR	15m	588-000	1+	£89.80	2+ £76.60
12x XLR	4x XLR	15m	588-190	1+	£111.40	2+ £97.30
12x XLR	4x XLR	30m	588-200	1+	£142.90	2+ £125.30
16x XLR	4x XLR	8m	588-970	1+	£99.70	2+ £88.40
16x XLR	4x XLR	15m	588-020	1+	£132.20	2+ £117.40
16x XLR	4x XLR	30m	588-030	1+	£141.30	2+ £129.90
24x XLR	4x XLR	15m	588-040	1+	£153.60	2+ £135.50
24x XLR	4x XLR	30m	588-050	1+	£217.20	2+ £194.90
16x XLR	8x XLR	15m	589-310	1+	£152.50	2+ £131.80
16x XLR	8x XLR	30m	589-320	1+	£199.60	2+ £179.30
24x XLR	8x XLR	15m	589-340	1+	£178.40	2+ £155.30
24x XLR	8x XLR	30m	589-350	1+	£239.80	2+ £218.30



XLR returns



Jack Returns

Inputs	Returns	Length	Code	Price (Ex VAT)		
8x XLR	4x Jack	8m	588-990	1+	£52.08	2+ £49.90
8x XLR	4x Jack	15m	588-060	1+	£89.80	2+ £76.70
12x XLR	4x Jack	8m	589-000	1+	£92.30	2+ £79.70
12x XLR	4x Jack	15m	588-210	1+	£109.90	2+ £96.40
12x XLR	4x Jack	30m	588-220	1+	£142.90	2+ £125.30
16x XLR	4x Jack	8m	589-010	1+	£99.60	2+ £84.80
16x XLR	4x Jack	15m	588-080	1+	£129.90	2+ £114.80
16x XLR	4x Jack	30m	588-090	1+	£161.30	2+ £142.90
24x XLR	4x Jack	8m	589-020	1+	£129.40	2+ £114.60
24x XLR	4x Jack	15m	588-100	1+	£158.60	2+ £139.90
24x XLR	4x Jack	30m	588-110	1+	£199.00	2+ £179.00
16x XLR	8x Jack	30m	590-100	1+	£203.90	2+ £181.60
24x XLR	8x Jack	30m	590-110	1+	£248.60	2+ £223.40



Jack returns



DELIVERY BEFORE NOON
no problem

DELIVERY BEFORE 10AM
no problem

SATURDAY DELIVERY
no problem

ALL PRICES EXCLUSIVE OF VAT.

Snakes

SNAKES

CONTINUED

Behringer S16

Digital Snake

Takes the burden out of connecting your Front of House console with the talent.



Digital mixing has revolutionized so much of the live-entertainment production workflow. But one thing that hasn't changed is having to roll out that heavy, cumbersome old analogue snake. That is until now! The S16 provides 16 fully programmable, remotely controllable high-end mic preamps plus 8 analogue, balanced XLR returns at the stage end, and connects to the FOH (Front Of House) via a single CAT5 cable without the need for a dedicated router. KLARK TEKNIK, a longtime industry-leader in the development of high-end digital audio processing, provided the SuperMAC technology that made all of this possible & BEHRINGER made it affordable.

Description	Code	Price (Ex VAT)
S16	383-830	1+ £515.83 2+ £507.50



Studiospares Cable Drum Snakes



High quality connectors are used throughout and should last a lifetime.

This 8 way multiway Cable Drum Snake consists of a tubular metal frame/stand containing a plastic drum with 8x XLR connectors. An on/off brake locks the drum in any position. A sensible rubber handle makes carrying much easier. Plugs and sockets are clearly numbered.

These drums include a newly developed fine braided mesh that covers the tails and extends from under the heatshrink and under the cable clamp inside the XLR. This greatly increases reliability. The cable is balanced with foil screening. 25m long.

Description	Code	Price (Ex VAT)
8x XLR Cable Drum	589-640	£69.40

Studiospares Enclosed Cable Drum Snakes

A really useful product that keeps cables tidy and has Thru sockets on the rear side.

- One side has male XLRs and female Jack or BNC, the reverse side has female XLRs and female Jacks or BNCs
- The Cable Reel Snake is fully enclosed
- A fine braided mesh that covers the tails and extends from under the heatshrink and under the cable clamp inside the XLR



Description	Length	Code
x6x XLR + 2x Jacks Side A 6x XLR female + 2x female Jacks Side B 6x XLR male + 2x female Jacks	15m	589-620

Description	Code	Price (Ex VAT)
6x XLR + 2x Jack 15m	589-620	1+ £72.50 2+ £66.50

Cable Drum Snakes

SNAKES

Cable Drum Snakes MK 2

Makes long cable runs so easy to retrieve....

Roll around snakes on drums make light work for on the road performers and engineers.

This product range is well made and is based on tried and tested engineering. Recently updated to include a reinforced axle. The drum includes a parking brake and lockable front castors. The multicore is a premium grade product using the more expensive spirally wound copper screening.



Manufactured to the ISO9001 standard. Due to the weight, delivery time is 2-3 days on these items.

Description	Length	Code	Price (Ex VAT)
8 way XLR female + 4 XLR male Drums	30m	589-030	1+ £167.30 2+ £149.40
12 way XLR female + 4 XLR male Drums	50m	589-060	1+ £234.50 2+ £212.80
16 way XLR female + 4 XLR male Drums	30m	588-150	1+ £239.00 2+ £217.00
16 way XLR female + 4 XLR male Drums	50m	588-160	1+ £283.00 2+ £255.00
24 way XLR female + 4 XLR male Drums	30m	588-170	1+ £272.00 2+ £245.00
32 way XLR female + 4 XLR male Drums	50m	589-080	1+ £332.00 2+ £305.00
Spare locking castor	-	448-240	1+ £6.95 5+ £6.25
Spare rear castor	-	448-250	1+ £4.95 5+ £4.45

PAYPAL

online payments

Worried about using your credit card online?

We now accept Paypal for online payment!



visit www.studiospares.com for more information

PDF catalogue

Want this catalogue on your phone or laptop?

The Studiospares catalogue is now available in PDF format.

visit www.studiospares.com/page/pdfcatalogue/

SATURDAY DELIVERY no problem

CLEARANCE

Limited quantity at amazing prices, but when it's gone... IT'S GONE!

SPECIAL OFFER!

Esmono pre-fab Voice Booth 2 x 2 x 2.2 metres, with door window and ventilation. Nearly new, it cost £9000 including installation and VAT. Dismantled as now surplus to requirements. Buyer collects only.

Offers? Contact luke@sound.co.uk



Name	Code	Quantity	WAS £	NOW £
KAM Starcluster Micro	226-510	1	49.00	39.00
Monacor PA-900 160W PA Mixing Amp	255-740	1	139.00	125.00
STAGELINE CD-112TRS CD/MP3 Player/Tuner	256-600	1	199.00	175.00
STAGELINE DPR-2004 PORTABLE RECORDER	256-630	1	69.00	62.00
STAGELINE CD-230DJ DUAL DJ CD/MP3 PLAYER	256-680	1	149.99	125.00
Mackie PPM 100B 8-Channel Powered Mixer	262-170	2	490.00	449.00
Mackie ONYX 1220i	262-340	1	500.00	449.00
Allen & Heath QU24 Digital Mixer	269-620	1	1700.00	1599.00
Denon DN-500C CD/iPOD Player	271-890	1	300.00	249.00
Yamaha O1V96i Digital Mixer 24/96	274-570	1	1150.00	1095.00
Numark CDMix Bluetooth	277-620	1	250.00	199.00
Line 6 Stagescape M20d Smart Mixing System	301-490	2	800.00	699.00
SM Pro TC02 2 Channel Tube Preamp/DI Box	303-090	1	109.99	99.00
SM Pro DI Dock Live Multi Channel Dock	303-170	1	95.00	85.00
SM Pro Tranz Wireless DI System - Transmitter	303-230	1	85.00	75.00
SM Pro Tranz Wireless DI System - Receiver	303-240	1	85.00	75.00
TRITONAUDIO Fethead Filter	314-010	2	49.00	39.00
IK iRig Mix Mobile Mixer	321-510	3	49.00	47.00
ART VoiceChannel Channel Strip	325-560	1	290.00	269.00
Presonus Faderport	328-020	1	89.00	79.00
Presonus TubePre	328-030	1	64.00	59.00
Presonus StudioLive 16.0.2	328-520	1	625.00	589.00
E-MU X MIDI 1x1 USB MIDI Interface	352-110	1	20.00	18.00
Samson S Com 4 Comp/Gate 4 Channel	368-530	1	110.00	95.00
Roland OP-R05C Cover/Windshield Set	369-920	3	36.00	25.00
MOTU 896HD Hybrid	375-240	1	649.00	599.00
iConnect MIDI2+	375-580	6	59.00	45.00
DBX 223s Stereo Crossover	379-170	2	109.00	99.00
DBX 223xs Stereo Crossover	379-180	2	120.00	109.00
Behringer Dual A/B Switch Ab200	380-340	4	20.00	15.00
Behringer Ultralight CFM-2 Crossfader	380-900	6	7.00	5.00
Behringer Europower EPQ900	382-730	2	105.00	99.00
Behringer Xenyx QX2222USB Mixer	383-850	1	165.00	155.00
Behringer X32 Core Digital Rack Mixer	383-910	2	499.00	465.00
Behringer NU4-6000 iNuke Power Amp	383-960	2	240.00	195.00
Behringer SPL3220 Sound Processor	383-990	1	80.00	73.00
Behringer X-MADI Madi Card for X32	384-063	1	199.00	179.00
Behringer Europower PMP580S Powered Mixer	384-090	2	189.00	174.00
Samson CH70 Headphones	388-540	6	13.00	12.00
Samson SR850 Headphones	388-550	1	20.00	18.00
Samson CH700 Reference Headphones	388-830	1	17.00	15.00
Samson Graphite M32 Mini MIDI Controller	388-990	1	36.00	32.00
Rycote Windjammer For H4N	408-600	1	23.00	19.50
Inter M PA-935A 100V Line Amp	427-660	1	85.00	79.00
Inter-M MA106 60W PA Mixer Amplifier	427-730	1	135.00	119.00
Beyerdynamic DT 990 Pro Headphones	430-200	1	90.00	84.00

Name	Code	Quantity	WAS £	NOW £
AKG HSC171 Headset	439-530	1	225.00	199.00
Sennheiser HD25-II BE Headphones	455-110	1	105.00	95.00
AKG K612 Pro Monitoring Headphones	469-210	1	100.00	89.00
Gator BMix 2020 Bag	471-180	1	27.00	25.00
Sennheiser HD439 Headphones	473-080	1	56.00	49.00
LED Lights Linkable x4	475-230	2	17.00	16.00
QTX LED Twister III	476-470	1	25.00	22.00
Hosa CDL-313 Digital Audio Interface	597-615	1	80.00	75.00
BB Blaster 10W Guitar Combo	601-300	1	30.00	27.00
Palmer PAND2 Active DI Box	602-870	1	32.00	29.00
Palmer PAN03 4-CHANNEL Active DI Box	602-880	1	120.00	112.00
Monacor IRS-200HT Handheld Mic	256-040	1	60.00	50.00
Stageline DPR-2004 MIC Add-on Microphone	256-640	1	12.00	10.00
MXL R144 Small Ribbon Mic	315-050	1	85.00	75.00
MXL V67i Dual Diaphragm Condenser	315-070	1	129.00	109.00
MXL Aria Condenser Mic	315-150	1	108.00	99.00
MXL Essentials Snare/Bass Drum Mic Kit	315-160	1	110.00	104.00
MXL CR30 Large Diaphragm Condenser	315-220	1	99.00	97.00
MXL FR-310 Hot Shoe Shotgun Mic	315-260	1	85.00	82.00
Heli RS-1	318-100	1	22.00	20.00
Zoom IQ5 White iPhone Stereo Mic	377-881	1	59.00	54.00
Behringer B2 Pro Condenser Mic	381-100	2	75.00	72.00
Samson CM11B Boundary Mic Omni	388-850	1	48.00	43.00
Samson CM11B Boundary Mic White	388-851	1	48.00	43.00
Samson MTR101 Studio Condenser	388-950	1	49.00	47.00
MicW i436 Omni Kit	403-155	1	79.00	74.00
MicW i456 KIT	403-905	1	95.00	58.00
AKG D230 Mic	409-121	1	109.00	87.00
Avantone CK1 Condenser Pencil Mic	413-630	1	85.00	79.00
Electro-Voice RE510 Hypercardioid Microphone	414-030	1	149.00	125.00
Electro-Voice RE20 Dynamic Mic	414-071	1	365.00	339.00
DPA 4060-BM Miniature High Sensitivity Mic	416-710	3	299.00	269.00
RyDE Lavalier Omni Lapel Mic	417-770	1	125.00	115.00
RyDE Stereo VideoMic Pro	417-930	1	135.00	115.00
Rode iXY iO5 Stereo Mic	417-960	1	104.00	95.00
AKG CK98 Short Shotgun	419-090	1	199.00	175.00
SE Electronics SE1A Condenser Mic	422-000	1	72.00	65.00
Audix SCX1-Hc Hypercardioid	422-570	4	449.00	375.00
Audix USB12 Podium Mic	432-000	1	99.00	53.00
TRANTEC S5.5 HDX CH38 Transmitter	434-220	1	259.00	229.00
Audio Technica ATR6550	447-100	1	49.00	45.00
Audio Technica ATW701H	447-650	1	159.00	145.00
Audio-Technica PRO70 Lavalier Mic	447-720	1	79.00	72.00
Audio-Technica ES945W Boundary Mic	447-730	1	95.00	92.00
Audio-Technica ATM650 Mic	447-840	1	70.00	59.00

All prices exclusive of VAT.

INDEX

Cases + Racks + Service	
Equipment Bags	276
Rack Bags	278
General Purpose Cases	278
Mic Carry Cases	279
Keyboard Cases	280
DJ Equipment Cases	280
Mixer Cases	280
Road/Rack Flight Cases	282
Wheeled Cases	285
Case Accessories	286
Studio Rack Housings	286
Rack Hardware	287
Rack Ventilation	288
Rack Panels	288
Rack Trays	289
Drawer Units	289
Rack Security	289
Rack Lighting	289
Jack Patch Panels	290
Bantam Patch Panels	291
Speaker Patch Panels	291
XLR Patch Panels	291
Universal Patch Panels	292
Wall Panels	292
Fuses	292
Velcro Hook and Loop Tape	292
Adhesive Tapes	292
Aerosols	293
Health & Safety	293
Batteries	294
Sound Level Meters	294
Multimeters	294
Illuminated Signs	294
Cable Testers	294
Specialised Hand Tools	296
Soldering Equipment	296
Staging	297

CASES

Equipment Bags

Speaker Bags Range

Durable padded fabric carry bags.

- The loudspeaker can be used while the case is still fitted offering limited protection against the elements
- Velcro attached flaps allow access to handle, top hat and terminals
- 10" Bag - 490 x 330 x 321mm
- 12" Bag - 630 x 440 x 400mm
- 15" Bag - 750 x 520 x 460mm
- **PLEASE NOTE:** The 15" PA Speaker bag will **not** fit the Studiospares Fortissimo Sub



Description	Code	Price (Ex VAT)
10" Speaker Bag	441-510	£19.70
12" Speaker Bag	441-520	£21.42
15" Speaker Bag	441-530	£25.50

Live LB Range

Equipment Bags

A range of carrying bags suitable for microphone, speaker and music stands.

LB10			
Microphone Stand Bag			
Length	Height	Depth	Code
1030	75	135	449-370



LB11			
Large Music Stand Bag			
Length	Height	Depth	Code
600	130	380	449-380



LB12			
Small Music Stand Bag			
Length	Height	Depth	Code
510	65	95	449-390



LB13*			
Long Music Stand Bag			
Length	Height	Depth	Code
1000	-	80	449-400



LB14			
Small Speaker Stand Bag			
Length	Height	Depth	Code
1110	110	120	449-410



LB15			
Medium Speaker Stand Bag			
Length	Height	Depth	Code
1390	110	150	449-420



LB16			
Large Speaker Stand Bag			
Length	Height	Depth	Code
1520	160	400	449-430



LB17			
Equipment Bag			
Length	Height	Depth	Code
1060	145	250	449-440



LB18			
Large Microphone Stand Bag			
Length	Height	Depth	Code
1230	85	180	449-450



Description	Code	Price (Ex VAT)
LB10	449-370	£3.70
LB11	449-380	£4.95
LB12	449-390	£4.40
LB13	449-400	£4.40
LB14	449-410	£4.57
LB15	449-420	£4.80
LB16	449-430	£6.50
LB17	449-440	£5.25
LB18	449-450	£4.60

Dimensions mm.

The Live stand bags are a high quality equipment bag range designed for use with microphone, speakers and music stands. Made of black waterproof hardwearing nylon designed to fit a variety of stands and equipment.

*Features two additional pockets for cables etc. 340x100x30mm.



Trojan B5 Range

Stand Bags

High quality stand bags designed for professional use.

B500			
Microphone Stand Bag			
Length	Height	Depth	Code
1030	75	135	458-860

B501			
Large Music Stand Bag			
Length	Height	Depth	Code
600	130	380	458-870

B502			
Small Music Stand Bag			
Length	Height	Depth	Code
510	65	95	458-880

B503*			
Long Music Stand Bag			
Length	Height	Depth	Code
1000	-	80	458-890

B504			
Small Speaker Stand Bag			
Length	Height	Depth	Code
1110	110	120	458-900

B505			
Medium Speaker Stand Bag			
Length	Height	Depth	Code
1390	110	150	458-910

B506			
Large Speaker Stand Bag			
Length	Height	Depth	Code
1520	160	400	458-920

B507			
Equipment Bag			
Length	Height	Depth	Code
1060	145	250	458-930

B508			
Large Microphone Stand Bag			
Length	Height	Depth	Code
1230	85	180	458-940



Description	Code	Price (Ex VAT)
B500	458-860	£5.57
B501	458-870	£7.95
B502	458-880	£6.85
B503	458-890	£6.95
B504	458-900	£6.95
B505	458-910	£7.45
B506	458-920	£9.15
B507	458-930	£7.88
B508	458-940	£7.30

Dimensions mm.

The Trojan B5 stand bags range are high quality equipment bags designed for professional use. Made of black waterproof hardwearing nylon designed to fit a variety of stands and equipment. Suitable for mic stands, speaker stands and music stands.

*Features two additional pockets for cables etc. 340x100x30mm.



K&M 15043

Universal Carry Case

Universal carrying case for multiple applications.

- Padded handles and adjustable shoulder strap.
- Plastic rubber feet
- 1000x180x180mm



K&M 14303

Universal Small Carry Case

Designed to hold 2 saxophone stands 14300 but has many uses.

- Tearproof water resistant material
- Sturdy nylon handles
- 470x200x150mm



K&M 26019

3x Mic Stand Carry Case

Sturdy carrying case designed for 3 round base mic stands.

- Padded handles and adjustable shoulder strap.
- Plastic rubber feet
- 1050x250x60mm



K&M 21315

6x Mic Stand Carry Case

Sturdy carrying case designed for 6 mic stands.

- Padded handles and adjustable shoulder strap.
- Plastic rubber feet
- 1100x180x220mm



Description	Code	Price (Ex VAT)
15043	478-630	£26.70
14303	478-640	£12.40
26019	478-650	£29.20
21315	478-660	£38.80

Gator Lightweight Mixer Bags

Designed to carry mixers safely.

- Heavy-duty EPS foam construction
- Padded Tricot lining & pyramid rubber feet
- Removable exterior accessory pocket
- Detachable padded shoulder strap
- Padded reinforced handles
- 600-Denier nylon exterior



Module	Description	Code
G-MIXL-1618	40.6 x 45.7 x 15.2	471-080
G-MIXL-1622	40.6 x 55.9 x 12.7	471-090
G-MIXL-1822	45.7 x 55.9 x 17.8	471-110

Description	Code	Price (Ex VAT)
1618	471-080	£41.20
1622	471-090	£43.30
1822	471-110	£47.50

Mic Transit Shoulder Bag

Padded transit bag with foam block holding up to 6 microphones and an adjacent segmented section for leads and other equipment.

- Additional 2-section outer pocket is included for accessories
- Fitted with handle and shoulder strap
- Twin adjustable fastening straps for lid
- Heavy duty 10mm padding
- External Dimensions 400 x 250 x 290mm
- Weight 920g



Description	Code	Price (Ex VAT)
Mic Transit Shoulder Bag	404-830	£24.99

ALL PRICES EXCLUSIVE OF VAT.

CASES

CASES

Rack Bags

SKB SC19

Soft Rack Case 1U/2U

Developed with the focus on portability and could be used for wireless microphone systems, pre-amps, effects etc.

- Constructed of a tough wood core covered by 600 Denier Nylon
- Adjustable shoulder strap and loop handle for easy transport
- Threaded steel rack rails are recessed to provide protection for equipment
- Available in 1U or 2U sizes

Description	Code	Price (Ex VAT)
1U	487-000	£42.20
2U	487-010	£52.40

Rack Bag 19"

The Rack Bag is a 19" rack case in a padded bag with front and rear flaps for access and ventilation.

- Sturdy internal wooden frame
- Rack strip front and rear
- Securing straps inside flaps
- Zipped external pocket
- Rack mounting depth 350mm
- Fitted with carrying handle, shoulder strap and zipped outer pocket



Description	Code	Price (Ex VAT)
2U	404-770	£37.80
3U	404-780	£41.50
4U	404-790	£45.50

Shallow Rack Bags 2U/3U/4U

19"

A range of shallow rack bags designed to protect valuable equipment from the rigours of the road.

- Front and rear rack rails.
- Depth 240mm
- Front and rear access/ventilation flaps
- Inner wooden frame for protection
- Zipped pouch for accessories, cables etc
- Carrying handle and shoulder strap



Description	Code	Price (Ex VAT)
2U	476-540	£35.50
3U	476-550	£41.20
4U	476-560	£45.80

General Purpose Cases

Trojan AL3

Carry Case

Many roadies use these for anything that will fit inside, even for things that really do not fit inside!

Lighter and cheaper than the traditional wooden/aluminium cases. Effective seal against moisture and dust etc. Comfortable carrying handle. Locking catches. Internally lined.

Dimensions external 426mmW x 285mmD x 165mmH.

Description	Code	Price (Ex VAT)
AL3	458-460	£16.60
AL3 + Picky Foam	458-465	£19.99



Trojan AL4

Carry Case

A really lightweight yet solid carrying case which backs up good looks with quality fittings.

- Edges have mating groove and lip to maintain rigidity and stop dust & debris entering
- Polished chrome bumpers and handle with a matt aluminium frame
- Removable and locking lid
- Metalwork riveted in place, not glued
- Interior lined with a rigid grey 4mm plastic
- Internal dimensions: Case 530mmW x 260mmH x 90mmD. Lid 55mmD



Description	Code	Price (Ex VAT)
AL4	458-730	£32.90
AL4 + 2x Picky Foam	458-735	£39.90

Trojan Wireless Case

5U Microphone Case

Designed specifically for rack mounting wireless radio mic systems.

- Lids are 70mm deep and foam filled to hold mics, leads accessories etc
- Front and back covers include Velcro Straps for mounting wireless radio mic transmitters and accessories
- Catches fully retract to allow for the removal of covers and lids.
- Rack rails front and back 264mm apart
- Recessed chrome butterfly catches are all industrial grade
- Spare 2U blanking panel



Description	Code	Price (Ex VAT)
Wireless 5U Case	458-710	£99.17

Trojan Roadie Toolcase

Adjustable Section Component/Toolcase

A versatile carrying case of aluminium and ABS which is practical and adaptable

- Compartment Dividers
- Dimensions mm
- 460W x 330L x 150D
- Resistant to impact damage
- Storage compartment in lid
- Rubber grip handle



Description	Code	Price (Ex VAT)
Roadie Toolcase	458-170	£19.50

Trojan Roadie Briefcase

With Picky Foam

A practical hardwearing tool case designed to carry specialised tools and equipment with the use of Picky Foam.

- 2mm thick ABS Case material is lightweight yet strong
- Lockable to minimise security risks
- Panel holding tools hinges down for access to documents
- Picky Foam easily customised to any shape
- Picky Foam size depth 100mm
- Inside dimensions mm: 440 x 310 x 150



Description	Code	Price (Ex VAT)
Roadie Briefcase	459-110	£32.50

Studiospares Roadie Cases x3

Locking Carry Cases x3

A really popular product for the "Roadie on the move".

- Strengthened corners and thicker internal padding ensure satisfaction
- Set of 3 cases
- Dimension mm a. 380W x 230L x 80D
- Dimension mm b. 420W x 290L x 120D
- Dimension mm c. 460W x 350L x 160DD



Description	Code	Price (Ex VAT)
Roadie Locking Cases x3	458-160	£29.00

WANT a job?

Are you looking for a stable and rewarding career?

Studiospares are constantly expanding. We require additional staff for a variety of positions, working in a very congenial atmosphere. Practical experience of recording and/or live sound engineering would be preferable.

send in your CV in the first instance

1000s of products Available from stock!

SKB 3i Series

Watertight Foam Case

Moulded of ultra high-strength polypropylene copolymer resin, featuring a gasketed, water and dust tight, submersible design.

- Comfortable, snap-down rubber over-moulded cushion grip handle
- Automatic ambient pressure equalisation valve
- Resistance to UV, solvents, corrosion, fungus and impact damage



NEW

Description	Code	Price (Ex VAT)
3i-0907-4B-01 for Zoom H4n	487-080	£57.50
3i-0907-4-H6 for Zoom H6	487-090	£69.58

Trojan Wheeled Mic Stand Case x6

Purpose made to accept practically all mic stands. 6 compartments.

- Internal length 1.00m
- Individual compartments 130mm square
- Sturdy Easy Roll wheels
- From the Trojan cases range
- Really heavy duty construction
- Overall dimension mm 1100 x 452 x 305



Description	Code	Price (Ex VAT)
Mic Stand Case x6	458-590	£112.50

Studiospares Wheeled Tool Case

Carry Case

With everything being on wheels, we thought why not introduce a tool case for engineers continually on the road.

- Retractable handle and heavy duty wheels makes light work of moving around on gigs
- Heavy duty case thickness 4.5mm ABS material
- Industrial grade handles, hinges and hardware
- Internal dimensions mm 550W x 380D x 21H



NEW

Description	Code	Price (Ex VAT)
Wheeled Tool Case	459-100	£104.17

Mic Carry Cases

CASES

Universal 3 In 1 Case Set

Ideal for the storage and transport of leads, accessories, tools, gaffer tape and much more.

- Set of 3 cases in red, blue and black
- Plastic covered plywood construction
- Aluminium edging and durable plastic corners
- Carry handles, and lockable drawbolt catches
- Clip-on shoulder strap included
- Foam rubber lining



Colour	Dimensions	Weight
Black	460 x 335 x 150mm	1.8kg
Blue	430 x 290 x 120mm	1.5kg
Red	400 x 250 x 90mm	1.2kg

Description	Code	Price (Ex VAT)
Universal 3 In 1 Case Set	475-650	£41.80

Trojan MCC Series
Microphone Carry Cases

Designed to ensure microphones in transit are guaranteed to arrive in the same condition as when they left.

Sufficient dimensions to accommodate any microphone. Casing based in heavy duty ABS material 3mm thick. The lid to case aluminium extrusion is tongued and grooved to prevent the entry of dust and rain. Extrusion is plated AFTER it is bent through 90 degrees to prevent discolouration through bending and stretching the surface plating. Foam layer under the hole stops microphone hitting the inside of the case. Sculptured foam in the lid protects microphone grille. Case supplied with a lock and key. Heavy duty hinges and handle. A quality product that should last a lifetime. Soft foam (hard foam can create dust if the microphone grille rubs against the foam in transit)

Description	Code	Price (Ex VAT)
Trojan MCC9 - 9 Mics	459-010	£37.50
Trojan MCC12 - 12 Mics	459-020	£47.50



NEW

TROJAN SERIES

SKB 3i Series

Watertight Foam Case

Moulded of ultra high-strength polypropylene copolymer resin, featuring a gasketed, water and dust tight, submersible design.

- Microphones housed in a foam pre cut to appropriate size
- Moulded-in hinge, patent pending "trigger release" latch system.
- Comfortable, snap-down rubber over-moulded cushion grip handle
- Automatic ambient pressure equalisation valve
- Resistance to UV, solvents, corrosion, fungus and impact damage



NEW

Description	Code	Price (Ex VAT)
3i-0907-MC3 3 Mics	487-060	£52.50
3i-2011-MC12 12 Mics	487-070	£107.50

SKB MIL-standard Case

Mic Carry Case for 6 Mics

MIL-Standard Waterproof Case moulded of ultra high-strength polypropylene copolymer resin.

- Waterproof and dust tight MIL-C-4150J
- Ambient pressure equalization valve
- Resistant to impact damage
- Special double layered padded dividers
- Snap-down rubber grip handle



Description	Code	Price (Ex VAT)
MIL-Standard Case	407-960	£63.50

Trojan Microphone Case

Mic Carry Case

An aluminium case that provides total protection for microphones on the move.

- Space for 16 microphones including large diameter condenser mics
- Space for accessories
- Carry handle on lid



Description	Code	Price (Ex VAT)
Trojan Microphone Case	458-520	£39.40

Microphone Flight Case

Large

Stylish design aluminium finish case for safe storage of microphones.

- Foam block interior which includes space for your leads and accessories
- Aluminium extrusions with a tough diamond patterned finish
- Carry handle and lockable catches via the supplied keys
- Dimensions 135 x 275 x 355mm



Description	Code	Price (Ex VAT)
Microphone Flight Case	475-640	£23.50

Wireless TXS-10 Belt

Transmitter Waist Bags

For attaching round the waist.

- Suitable for most wireless pocket transmitters
- Flexible, adjustable strap
- Blue bag with velcro fastener



Description	Code	Price (Ex VAT)
TXS-10	255-380	£9.50

VISIT
our trade counter
You'll get friendly advice and immediate access to 8000+ product lines!
free parking for 40 cars

MORE PRODUCTS
online

Mic Carry Cases

CASES

CONTINUED

Gator GM-15-TSA

15 Mic Carrying Case

This ATA moulded case houses 15 microphone drops and accessories, within its lightweight polyethylene exterior.

- TSA combination number coded locking latches; No keys
- Mics held in place by a foam pad inside lid
- Interior dimensions mm: 420W x 285H x 196D



Description	Code	Price (Ex VAT)
GM-15-TSA 15-Mic	471-240	£68.00

Gator GM-6-PE

6 Mic Carrying Case

ATA Moulded 6 Slot Mic Briefcase.

- Lightweight polyethylene construction
- Triple chrome-plated locking latches
- Exterior dimensions mm: 330L x 202W x 126D
- Weight 1.8kg



Description	Code	Price (Ex VAT)
GM-6-PE 6-Mic	471-250	£32.50

Keyboard Cases

CASES

Gator GKPE-88-TSA

ATA Keyboard Case

Moulded from incredibly durable high-density military grade Polyethylene.

- ATA Moulded PE Case w/ Wheels
- Extra Interior Depth for 88 Note Keyboards
- Unique wedge and block design for interior customising
- 2 TSA locking latches with impact diversion dishes
- 90kg recessed in-line wheel weight capacity
- Two rubber gripped handles 60kg maximum weight capacity
- Solid aluminium valance with black powder coated finish



Description	Code	Price (Ex VAT)
GKPE-88-TSA	471-360	£199.17

PRICE changes

This catalogue was priced on 1st December 2014.

Current prices may be higher...

see our website for up to date prices.

Studiospares PROKB Series Keyboard Case

These cases offer protection second to none.

Keyboards in transit are vulnerable. 9mm Plywood, aluminium extrusions, recessed wheels and a padded interior with guaranteed quality. Recessed locks, three handles, ball corner protectors and recessed wheels. Foam adjustable for differing size keyboards.



The Studiospares series of keyboard cases demonstrates how quality need not be expensive. We sell direct to the end user cutting out the middle man and import these by the container load.

Model	Description	Code
61PROKB	61 Key 1165mm x 430mm x 190mm internal space	458-560
76PROKB	76 Key 1350mm x 450mm x 190mm internal space	458-570
88PROKB	88 Key 1520mm x 555mm x 190mm internal space	458-580

Description	Code	Price (Ex VAT)
61PROKB	458-560	£89.70
76PROKB	458-570	£107.50
88PROKB	458-580	£124.80

Studiospares

DJ Equipment Cases

CASES

Trojan DJ Table

DJ Table Case



An ingenious design where everything locks together to form a substantial DJ working environment.

It includes a full width shelf and recessed castors. Can be dismantled within seconds to form an easily managed rollaround unit. Constructed to the high standards of all the Trojan products. Collapsed W900 x H965 x D75mm; Extended W1485 x H965 x D515mm

Description	Code	Price (Ex VAT)
Trojan DJ Table	458-400	£115.00

SKB 84DJ

DJ Shuttle

Highly affordable and very reliable entry level DJ case.

- Moulded-in handles and a durable padded cover
- Offers 8U of rack space on top and 4U underneath
- The depth of the top part varies from 133mm at the back to 63mm at the front



Description	Code	Price (Ex VAT)
DJ Shuttle	406-890	£78.20

Gator GDJ Series

DJ Rack Cases

The Gator GDJ series are moulded PE slant top DJ console rack cases.

- They are rotational moulded polyethylene cases
- The cover is made from 420-Denier nylon
- They also feature heavy-duty rack rails
- Moulded-in carry handles



Case	Dimensions	Code
GDJ8x2	8U + 2U Rack depth 390mm	471-210
GDJ8x4	8U + 4U Rack depth 390mm	471-220
GDJ10x6	10U + 6U Rack depth 444mm	471-230

Description	Code	Price (Ex VAT)
GDJ8x2	471-210	£65.00
GDJ8x4	471-220	£74.17
GDJ10x6	471-230	£89.00

Mixer Cases

CASES

Citronic 19" Mixer Case

Made from 9mm plywood with matte vinyl outer surface finish.

- Fitted with four padded and comfortable carrying handles
- Corners use bubble type protectors
- Front and top cover secured by strong catches
- Removable rear cover and secured by quarter turn twistcatches
- Aluminium extrusions protect all edges
- Black rackstrip at the front supports all standard 19" equipment
- Supplied with screws and caged nuts
- Two versions with different equipment spaces, 2U or 4U



Description	Code	Price (Ex VAT)
2U	475-070	£80.84
4U	475-080	£101.28

DELIVERY BEFORE NOON
no problem

SATURDAY DELIVERY
no problem

DELIVERY BEFORE 10AM
no problem

Trojan MC4U/MC16U-12U

Mixer Cases

Mixer series with the finest available fittings and a build quality second to none...

The MC4U-12U table top mixer case has a 4U vertical space and 12U mixer space 30 degrees off horizontal fixed tilt and a lift-off lid and rear panel for cable access. The MC16U case provides an additional 89mm (2U) of rack space for the mixers depth. 4U for table top operation with a handle either side and a 16U version includes four handles and castors, two of which have brakes. Clearance from top of mixer rack strip to inside of lid is 20mm and from the back end of the mixer rackstrip to rear panel – 35mm.

These cases come direct to you via Studiospares from one of the largest case manufacturers in the world. Cases are fully ROHS compliant. We guarantee these cases are of the highest quality, they have to be, they bear the Studiospares name!

Trojan AMC16U-12U

Pop-Up Mixer Case With Legs

This version is a variant of the MC16U where the mixer can be set at any angle. There is 12U of mixer space. Rear access is a hinged rear door. Front and rear covers form tables either side of the case. Table tops measure 900mm x 500mm and are 715mm from the ground.

The legs retract inside the lids and are held in place by Velcro straps for transportation purposes.

Description	Code	Price (Ex VAT)
MC4U-12U	458-370	£72.50
MC16U-12U	458-360	£159.00
AMC16U-12U	458-390	£179.00



MC4U



MC16U-12U

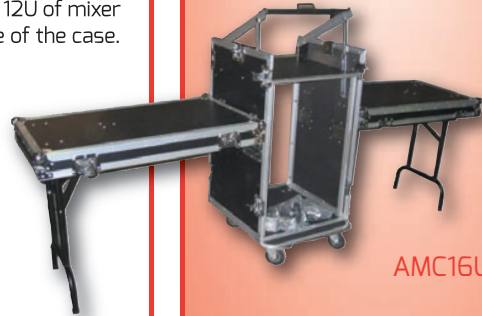

AMC16U-12U

Trojan MKII

Pop Up 12U Mixer Case

Designed to ensure that equipment arrives at it's destination in good shape.

The mechanism, locks and extrusions are all of the highest quality. The construction is of 3mm ABS with built in bracing for maximum strength. Space below mounting rail 10cm and 9cm within the detachable lid. The equipment mounting strip is threaded (M5) so it is impossible to lose caged nuts. Sold at a price well below any competitor because we source directly from one of the largest factories in the industry. We purchase by the container load and enjoy the benefits of bulk buying. Revised lid catches are sprung to maintain even tension. Dims. mm 540W x 600D x 200H. Weight 8.0kg. Complete with rack hardware. Suitable for the Yamaha MG rackmountable Series Mixer.



Description	Code	Price (Ex VAT)
Trojan MKII Case	458-700	£64.40

Trojan Mixer Case

With Sliding Laptop Shelf

With Laptops, not turntables and CD players becoming the preferred media choice, this model will find a lot of takers.

- Laptop shelf slides backwards on rails
- Secured in place by a chrome pin which is retained by a chain so it cannot be lost
- OK for 17" laptops.



Description	Code	Price (Ex VAT)
Mixer Case with Shelf	458-480	£99.00

Pro Mixer Case 12U

Adjustable 19" Case

Provides the highest degree of protection available.

- 12U mixer space available
- Recessed handle
- Includes mounting screws
- 9mm Plywood construction
- Highest quality hardware currently available
- Fully ROHS compliant



Description	Code	Price (Ex VAT)
Mixer Case 12U 19"	458-800	£57.40

1000s
of products
Available from stock!

VISIT
our trade counter
You'll get friendly advice and immediate access to 8000+ product lines!

MORE PRODUCTS
online

ALL PRICES EXCLUSIVE OF VAT.

Mixer Cases

CASES

CONTINUED

Trojan X32 Compact

Mixer Case

Professional grade mixer case designed for the Behringer X32 Compact.

Constructed from 9mm plywood and aluminium and built to a high standard, this case is designed to protect the X32 Compact from knocks and scrapes during transit and use. The plywood has been covered with a layer of laminated plastic making it stronger and resistant to marking. The lid detaches completely from the bottom of the case, and is secured using 4 butterfly latches. There are two recessed metal handles with rubber grips on each side, allowing the case to be easily carried by two people. All edges and corners are reinforced with heavy-duty aluminium. The interior is lined with high density foam offering a high degree of protection to the mixer.



Description	Code	Price (Ex VAT)
X32 Compact Case	458-960	£129.00

Trojan X32 Wheeled

4-Drawer Case

Designed specifically for the Behringer X32 and accessories.

- 4-Wheels, 4-lockable drawers for accessories and a lift off lid
- Constructed from 9mm plywood faced with a tough and attractive Black Phenolic surface
- Corners are protected by chrome plated steel bumpers
- Catches fully retract



Description	Code	Price (Ex VAT)
X32 Wheeled Case	458-720	£270.00

Trojan X32 Rollaround

Mixer Case

Based on the X32 and includes a lid, 10U of rack space for processors and amps plus two substantial, lockable drawers.

- Rear access door to rack section
- Top drawer mm 150 high x 350 wide x 350 deep
- Bottom drawer mm 250 high x 350 wide x 350 deep
- Industrial quality locking castors
- Four side handles make transportation a breeze



Description	Code	Price (Ex VAT)
X32 Rollaround Case	459-070	£249.00

Gator G-TOUR X32

X32 Case

Features a thick, 12mm heavy duty plywood construction and a tough laminated PVC exterior.

- A unique doghouse design which helps secure the mixer inside and provides easy cable routing and full rear access while in the case.
- Spring loaded carrying handles
- Specialised EVA foam padding
- Detachable lids and heavy duty castors
- External dimensions mm: 1008W x 925L x 280H
- Weight 47kg



Description	Code	Price (Ex VAT)
G-Tour X32	471-200	£299.00

Trojan QU Cases

Mixer Cases

Based on 9mm Eucalyptus plywood chosen for its strength and light weight.

- Two recessed metal handles with rubber grips make transportation a breeze
- Surrounded and protected by a dense foam
- Aluminium strip between lids and case sexed to form a seal against debris and rain
- High Balls protect corners against damage
- Lift off lid secured by four butterfly catches

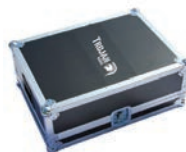

Description	Code	Price (Ex VAT)
QU-16 Case	459-080	£165.83
QU-24 Case	459-090	£199.00

GRC-10x6/GRC-10x8

Slant Top Console Rack

Moulded from incredibly durable high-density military grade Polyethylene.

- Locking front, top and rear lids
- Chrome plated corner protectors
- Rear wire access
- Two carrying handles
- Interior horizontal depth 500mm
- GRC-10x6 - 10 U horizontal top + 6 U front vertical
- GRC-10x8 - 10 U horizontal top + 8 U front vertical



Description	Code	Price (Ex VAT)
GRC-10x6	471-340	£132.50
GRC-10x8	471-350	£137.50

Road/Rack Flight Cases

CASES

SKB X Rack

Road/Rack Case

A lightweight roto-moulded alternative to the well established SKB ATA range of road cases. The roto moulded X-Racks are durable and the "X" pattern provides for secure stacking.

- Rear access panel
- Hardware is provided
- Shock absorbing feet
- Recessed latches
- Moulded-in handle



Description	Code	Price (Ex VAT)
X Rack 2U	406-170	£57.50
X Rack 3U	406-180	£69.50
X Rack 4U	406-190	£82.50

SKB 1SKB Series

Shallow Rack Cases

The re-designed Roto-molded Shallow Rack Cases now have full front and rear covers.

- Shallow Racks are roto-molded for strength and durability
- Interlocking footprint makes stacking safe
- Mil-Spec black twist latches and shock absorbing rubber feet
- Heavy-duty flush handles.
- Gear can be mounted front and rear with the supplied rackmount clips
- Interior Width: 48.26 cm
- Interior Height: 13.34 cm
- Rackable Depth: 27.18 cm
- Both doors have a rubber gasket to keep water out of the case



Description	Code	Price (Ex VAT)
1SKB-R25 2U	487-100	£99.17
1SKB-R35 3U	487-110	£107.50
1SKB-R45 4U	487-120	£115.83
1SKB-R65 6U	487-130	£124.17

Shallow Rack Cases

Rack Cases

ABS plastic rack cases for 19" equipment with shallow depths. Ideal for wireless microphones, audio processors and rack mixers.

- Front and rear rack rails.
- Depth 355mm
- Front and rear lids
- Comfortable carrying handles
- Stackable. Includes M5 fixing screws



Description	Code	Price (Ex VAT)
2U	476-570	£49.99
3U	476-580	£55.50
4U	476-590	£66.50

VISIT our trade counter

You'll get friendly advice and immediate access to 8000+ product lines!

1000s of products Available from stock!

Trojan MKII ABS Cases

Road Cases

Designed to ensure that equipment arrives at its destination in good shape.

Following the success of the Trojan ABS Cases we now introduce an updated version with three revisions.

1. For increased strength the case thickness is increased from 2.5mm to 3mm.
2. Drawbolt tension is more consistent with the inclusion of tension springs.
3. Discolouration of the aluminium extrusions corners is solved by plating the aluminium AFTER it is bent through 90 degrees.

These ABS cases have rackstrip BOTH ENDS. Bracing is moulded into the body and lids to provide added rigidity. A gasket is sunk into the edge of the lid. This is compressed by a lip on the body to form a tight seal against dirt and liquids. Drawbolt locks are fitted to make the lid shut tight. Cases may be stacked without sliding off. Corners are strengthened by metal plates to form the anchoring point for the equipment. The equipment mounting strip is threaded (M5) so it is impossible to lose caged nuts. Case length is 550mm which is slightly longer than most. Plugs can therefore remain permanently connected during transit. The distance between rackstrips is 480mm. We purchase by the container load and sell directly to the end user so our prices will always be lower than competitors. Purchasing direct from Studiospares cuts one step out of the distribution chain, where each step increases the price.



2U



12U

Trojan MKII ABS Wheeled Case

Identical to the flight cases above but includes a telescopic handle. Decent low friction wheels designed to roll around with ease. Sold at a fraction of competitive products through cutting out the importer and the dealer. Purchasing direct from Studiospares cuts one step out of the distribution chain, where each step increases the price.



8U + 2U Wheeled

Description	Code	Price (Ex VAT)
2U	458-600	£39.50
3U	458-610	£43.80
4U	458-620	£48.20
6U	458-630	£54.30
8U	458-640	£59.30
12U	458-650	£68.00
4U + 2U Wheeled	458-660	£61.30
6U + 2U Wheeled	458-670	£65.83
8U + 2U Wheeled	458-680	£79.40

Wheeled Cases - Please Note:

The bottom 1U of space is occupied by the wheels and handle from a point 35mm behind the rack supports. The space is therefore restricted to ventilation panels, connector panels or blanking plates. To offset this loss of space we provide an additional 2U of space free of charge. That way you will receive a case with the clear space you have ordered.



Gator GRR-4L/GRR-6L

Rolling Rack Case

Moulded from incredibly durable high-density military grade Polyethylene.

- Locking front and rear lids
- 7 mm zinc plated front and rear rack rails
- Rugged pull-out handle and Roller blade-style wheels
- Latches are strong twist style



Description	Code	Price (Ex VAT)
GRR-4L 4U	471-320	£104.17
GRR-6L 6U	471-330	£112.50

Trojan FC4

4-Drawer Flight Case

Designed for carrying all the paraphernalia connected to getting the show on the road.

- Four metal rubber covered recessed handles
- Four heavyweight industrial wheels
- Corners protected by steel balls
- Bins each 600mm x 400mm, 4 heights mm 120 + 175 + 230 + 340
- Dimensions: mm 1005H x 658W x 435D



Description	Code	Price (Ex VAT)
FC4	459-000	£249.17



Trojan Shockmount Roadcases

More reliable than spring support systems which can go into oscillation.

- 9mm Plywood construction
- Black Phenolic easy clean surface
- Very high quality hardware
- Retractable handles
- Pliable springy rubber surrounds the rack cage
- The best insurance against mechanical shock

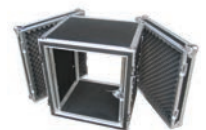

Description	Code	Price (Ex VAT)
4U	458-490	£98.50
8U	458-500	£124.00

ALL PRICES EXCLUSIVE OF VAT.

CASES
Road/Rack Flight Cases

CASES

CONTINUED

Trojan Roadcase Range

Road Cases

Designed by the very people who use them...

Their design has been continually refined and updated. All fittings are the finest available and the build quality is second to none. Constructed from 9mm plywood faced with a tough and attractive Black Phenolic surface which is used throughout. Corners are protected by chrome plated steel balls secured to the cabinet in six places. Catches fully retract to allow for the easy removal of covers and lids. Quick Release hinges minimise hassle and frustration. Recessed chrome butterfly catches are all industrial grade secured to the case with ten rivets designed specifically for the purpose. Lids include lips that form seals against moisture and debris that are all part of protecting equipment on the move. In a nutshell, quality is the keyword.

The 2U version has a retractable handle on the lid. 4U to 8U cases have one handle each side, 10U to 16U cases have two handles either side plus 8 butterfly latches. 12U, 16U and 20U versions include a castor board with four castors, two with brakes. All cases have a depth of 520mm except the 2U version which is 410mm. Equipment mounting hardware is included. All versions have front and back covers with equipment mounting rails back and front. Covers can be locked together to form a useful box in its own right.

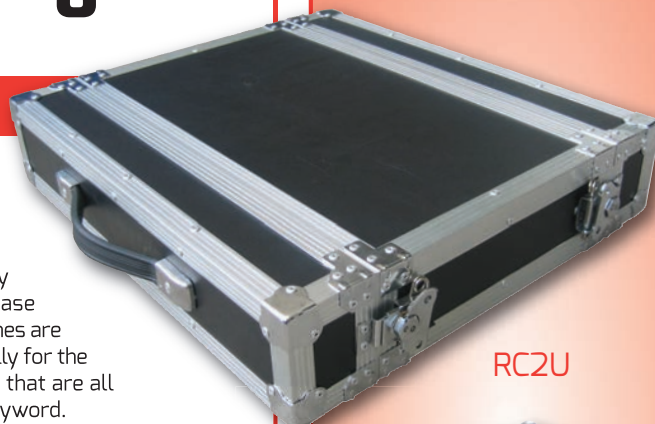

RC2U



RC16U

Description	Code	Price (Ex VAT)
RC2U	458-300	£47.30
RC4U	458-310	£59.20
RC6U	458-320	£65.70
RC8U	458-330	£75.20
RC12U	458-340	£96.60
RC16U	458-350	£119.70
RC20U	458-470	£147.50
Wheel Base Transporter	458-380	£38.30



Studiospares Half Depth Cases

8" ABS Rack Cases

Same high grade construction as the full depth cases.

- Bracing is moulded into the body and lids
- Drawbolt locks are fitted to make the lid shut tight
- Cases may be stacked without sliding off
- Corners are strengthened by metal plates to form the anchoring point for the equipment
- Mounting strip is threaded (M5) so impossible to lose caged nuts
- Discolouration of the aluminium extrusions corners is solved by plating the aluminium AFTER it is bent through 90 degrees
- A gasket is sunk into the edge of the lid to form a tight seal



Description	Code	Price (Ex VAT)
2U	459-030	£33.30
3U	459-040	£38.50
4U	459-050	£43.70
6U	459-060	£48.90



SKB ATA Road Cases

A lightweight roto-moulded alternative to the well established SKB ATA range of road cases.

- Case material is military grade 50-100 ultra high molecular weight polyethylene
- Stackable and half the weight of wooden boxes
- Draw tight latched front and rear covers are gasket sealed
- Snap nuts are provided for securing the equipment into the 19" mounting flanges



Description	Code	Price (Ex VAT)
2U	406-430	£104.50
3U	900-141	£108.50
4U	406-440	£114.60
6U	406-210	£127.40
8U	406-451	£165.00
12U	406-461	£178.00
Optional Nut and Bolt Kit	404-360	£10.84
Optional Castor Kit	405-510	£65.30

Gator GR Series

Rack Cases

Moulded from incredibly durable high-density military grade Polyethylene.

- Locking front and rear lids
- 7 mm zinc plated front and rear rack rails
- Stackable with most other rack cases
- Latches are strong twist style
- Sloped side handles make them comfortable to carry when loaded
- Max equipment depth 490mm
- Complete with M5 screws
- 5 series - The same specifications but with a reduced depth of 360mm



Description	Code	Price (Ex VAT)
GR-2L 2U	471-290	£79.00
GR-4L 4U	471-300	£87.50
GR-8L 8U	471-310	£112.50
GR-2S 2U Shallow	471-260	£82.50
GR-3S 3U Shallow	471-270	£87.50
GR-4S 4U Shallow	471-280	£92.50

DELIVERY BEFORE NOON
no problem

SATURDAY DELIVERY
no problem

DELIVERY BEFORE 10AM
no problem

Trojan AMC12U-12U

Wheeled Rack Case

A Heavy Duty Rack Case with 12U of racking and 12U of mixer space.

Based on 9mm Eucalyptus plywood selected for strength and light weight. Aluminium strip between lids and case sexed to form a seal against debris and rain. Steel High Balls protect corners. Mixer section raises to an angle on ratchet bars. Industrial locking wheels and recessed side handles make transportation simple. Rackstrip front and rear.

Supplied in a heavy duty corrugated cardboard carton and with caged nuts and bolts.

Description	Code	Price (Ex VAT)
AMC12U-12U	458-740	£149.00



Trojan Wheel Base For 19" Flightcases

The only castor plate that looks good because the components are of the highest quality.

- Fabricated from vinyl faced 15mm plywood and edged with an aluminium extrusion
- Two wheels are locking
- Purchased by the container load directly from one of the industry's largest manufacturers
- Buying direct cuts out the middle man!



Description	Code	Price (Ex VAT)
Trojan Wheel Case	458-380	£38.30

Wheel Base For 19" Flightcases

A useful addition for anyone on the move.

- Sturdy Black painted plywood base
- Heavy duty rubber wheeled castors at each corner
- Two castors have brakes
- Dimensions mm 610 x 510



Description	Code	Price (Ex VAT)
Wheeled Base	475-120	£29.60

Trojan RS2U/4U/8U

Roadcases

Designed to accommodate shallower processing and amplifying equipment.

- Fabricated from 9mm plywood
- Distance between rack strip and rear of sleeve 270mm
- Distance between rack strip and inside of rear cover 350mm
- Front and rear cover inside depth 73mm
- Width overall 555mm



Description	Code	Price (Ex VAT)
RC2U 2U 205mm Depth	458-970	£43.30
RC4U 4U 300mm Depth	458-980	£52.50
RC8U 8U 300mm Depth	458-990	£65.70

Trojan 2U Twin Flip Case

Rack Case

Requested by performers wanting a case that folded down to 2U for transportation.

- Fabricated from 9mm Eucalyptus plywood for greatest strength
- Industrial round feet protect all surfaces. They are screwed into T Nuts and NOT to the plywood
- Butterfly catches pull aluminium extrusions tight together
- Aluminium extrusions sexed to create a seal against dirt and rain
- Steel High Balls to protect corners



Description	Code	Price (Ex VAT)
Twin Flip Rack Case	458-750	£82.50

Trojan 1x/2x

4-Drawer Flightcase

A robust and practical carrier for all the paraphernalia associated with working away from base.

- Based on 9mm Eucalyptus plywood for greatest strength
- Two versions: 1x with four drawers and a front lid and 2x consisting of two 1x which lock together
- 4 equal sized locking drawers
- Drawer size mm 530W x 100H x 430D



Description	Code	Price (Ex VAT)
1x	458-770	£185.00
2x	458-760	£282.50

Wheeled Cases

Trojan Rollaround

Wheeled General Purpose Case

Designed to house all the odds and ends used at a function, such as Leads, mics, headphones, compact mixers and tools.

Constructed from 9mm plywood faced with a tough and attractive black vinyl surface which is used throughout. Corners are protected by chrome plated steel balls secured to the cabinet in six places. Catches fully retract to allow for the easy removal of covers and lids. Quick Release hinges minimise hassle and frustration.

Recessed chrome butterfly catches are all industrial grade. Foam lined interior.

Telescopic handle and recessed wheels.

Description	Code	Price (Ex VAT)
Trojan Rollaround	458-510	£63.30



Trojan Roadie

7-Drawer Wheeled Case

Extremely useful 7 drawer roadie case with a lift off lid forming a desk or bench.

9mm plywood construction. 7x drawers (3 x 88mm high, 3 x 132mm high, 1 x 264mm high). Ext 520mm wide x 525 deep x 967 high. 4 handles, 4 butterfly catches. Lift off lid/bench 967mm x 525mm. Laminated plastic covering.

Description	Code	Price (Ex VAT)
Trojan Roadie	458-540	£153.00



FOR
fax orders
Use our fax number...
020 8450 4390

VISIT
our trade counter
You'll get friendly advice and immediate access to 8000+ product lines!
free parking for 40 cars

Wheeled Cases

CASES

CONTINUED

Citronic 8U/16U

Equipment Rack with Wheels

Made from 9mm plywood whose outer surface has a matte vinyl finish...

Fitted with four heavy duty handles. Corners use bubble type protectors. Front cover has catches either side. Aluminium extrusions protect all edges.

Black rackstrip at the front supports all standard 19" equipment. Lid lifts off. Total internal depth 500mm. Two castors are lockable.

Requires M6 Caged nuts.

Description	Code	Price (Ex VAT)
8U	475-150	£189.00
16U	475-060	£212.50

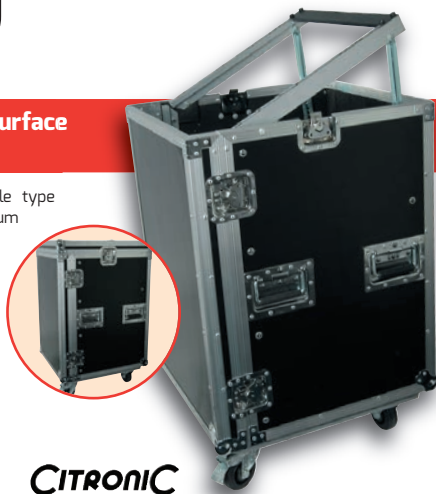

CITRONIC

Case Accessories

CASES

Studiospares Picky Foam

Case Interior Foam

A really useful diced foam which can be used inside any box.

- Individual segments can be removed to provide a bespoke shaped cut out
- Dimensions 500 x 500 x 60mm thick



Picture illustrates a small area

Description	Code	Price (Ex VAT)
Picky Foam	458-150	£8.20

Studio Rack Housings

RACKS

Studiospares Stackrack 16U

The 16U high StackRack has been slowly developed in the light of 'hands on' experience.

- Robust system
- Finished in Black epoxy resin for durability and clean appearance
- 16U high (28 inches of Rack space)
- Overall depth 38.5cm
- Rear uprights can be secured to walls and furniture for greater security
- Supplied flat packed with all assembly screws and twenty x M5 equipment fixing screws



NEW LOWER PRICE

Description	Code	Price (Ex VAT)
StackRack	401-241	£24.96
Optional M5 Screws Pack of 20	440-440	£2.64

1000s
of products
Available from stock!

Equipment Rack Cabinet

12U/20U/28U

The Studiospares Equipment Cabinet is constructed from 18 gauge 1mm thick steel.

Sides are secured to top and base units by Black M4 screws driven into hank bushes for strength and rigidity. The cabinet design is symmetrical enabling equipment to be mounted from front or back or both. Equipment recessed by 23mm. The cabinet is well constructed with much attention to detail. For durability, all surfaces are coated in Black epoxy resin. Depth between front and back supports 390mm. Supplied flat packed. Nuts and bolts to be ordered separately.



Description	Code	Price (Ex VAT)
8U 461H x 545W x 436D	403-830	£72.50
12U 639H x 545W x 436D	402-781	£58.30
20U 995H x 545W x 436D	402-791	£98.00
28U 1351H x 545W x 436D	402-841	£124.00
35U 1662H x 545W x 436D	403-840	£159.00

Stackable Equipment Cabinet 4U

Provides an inexpensive means of housing 4U of 19inch rack equipment.

- Manufactured from 1.4mm steel
- Stackable as feet automatically locate
- Dimensions mm 490W x 190H x 300D
- Black epoxy finish



Description	Code	Price (Ex VAT)
4U Stackable Cabinet	406-510	£26.30

Studiospares 23U

Operational Rack

A really convenient and versatile rack, which is shipped flat packed.

- Top section which is about 60 degrees from the horizontal accommodates 4U of equipment
- The next section takes 2U and the vertical section 17U
- Fully adjustable short stand with boom arm is attached to the left side
- The front castors are locking
- Overall height is 1290mm. The base size is 560mm wide and 580mm deep



Description	Code	Price (Ex VAT)
23U	448-280	£49.50

Europa Roll Around

19" Equipment Trolley

All steel construction with black painted finish.

- 12U of equipment space on the upper part that can be rotated through 20 degrees
- 8U of rack space in the lower section
- Locking front castors
- Shipped flat packed for easy transportation
- Includes a kit of caged nuts
- Manufactured in accordance with ISO9001



Description	Code	Price (Ex VAT)
Equipment Trolley	448-230	£66.30
Spare Rear Wheels	448-250	£4.95
Spare Front Locking Wheels	448-240	£6.95

K&M 48260

19" Rack

Sturdy steel 19" rack with rack rails on the front and back sides.

- Sloped front
- 4 castors are included for easy movement and transportation
- Choice of 16U or 21U models
- Depth at the top 425mm/390mm, and height 840mm/1070mm, depth at the top 561mm for both models



Description	Code	Price (Ex VAT)
48260 16U	438-390	£149.00
48260 21U	438-400	£169.00

Studiospares Frame Equipment Racks

A highly practical means of mounting up to 20U or 35U of equipment in an open rack.

- Designed for permanent installation or roll around applications
- Substantial castors have one pair locking
- For permanent installations the feet are wound down raising the castors clear of the ground
- Front to back distance between the supporting feet is variable between 600mm and 800mm. Width is 560mm
- There is rackstrip front and back.
- Colour mid Grey

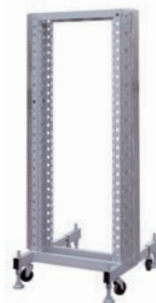

Description	Code	Price (Ex VAT)
20U	458-020	£109.50
35U	458-030	£125.00

Wooden 19" Rack Cabinets

Studio Rack Housings

Quality laminated cabinets with rack strips either side.

The sloping front cabinet's top section houses 8U of equipment and varies in depth between 300mm and 450mm. The lower section has two options. 6U of rack strip or a sliding shelf. Both include castors. To avoid the inherent problems of damage during transportation this product is now supplied flat packed (FP). (Except models with a sloping front which are shipped ready assembled AS). Everything simply locks into position by turning a cam/screw a quarter turn. Should even greater rigidity be required, internal metal corner plates are provided and wooden dowels plug into pre aligned holes.

Description	Code	Price (Ex VAT)
8U + 6U Sloping Cabinet (AS)	457-000	£199.00
8U + 6U Sloping Shelf (AS)	457-100	£189.00
8U Sloping Cabinet (AS)	457-190	£119.00

Four models of vertically stacked equipment. All versions 450mm deep. (FP)

Description	Code	Price (Ex VAT)
4U Cabinet (FP)	457-020	£82.40
6U Cabinet (FP)	457-030	£92.60
8U Cabinet (FP)	457-040	£96.50
12U Cabinet (FP)	457-050	£119.50
M6 Caged Nuts Sold Singly	900-070	£0.35



4U 6U 8U 12U

8U SLOPING CABINET

Manufactured from 18mm MDF with a Steamed Beech finish.



RACKS

Rack Hardware

Rack Screws/Nuts/Washers x50



A 50 pack of Cage Nuts, Plastic Washers and M6 Bolts.

- Plastic washer saves marking equipment
- Zinc plated normal size cage nut
- X head bolts
- 50 of each item

Description	Code	Price (Ex VAT)
Scews/Nuts/Washers x 50	458-820	£16.60

Rackstrip



8U, 16U, and 24U lengths of Rackstrip 28 inches long.

- Punched out of heavy gauge steel with 5mm dia. holes along the side for fixing to walls, furniture, cabinets etc
- Distance between vertical side supports should be 486mm
- Provides correct alignment of the holes and leaves a 450mm opening
- Use normal Cage Nuts. (Code 401-320)

Description	Code	Price (Ex VAT)
Rackstrip 8U	900-075	£7.04
Rackstrip 16U	401-680	£8.25
Rackstrip 24U	900-076	£11.52

Pre-Cut Rackstrip Lengths

Similar to the Rackstrip above but pre cut into convenient short lengths.

- Passivated finish so will not rust
- Each length has two 6mm diameter side fixing holes
- Available in four sizes: 1U, 2U, 3U and 4U

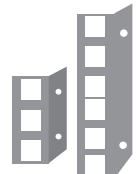

Description	Code	Price (Ex VAT)
1U	404-610	£3.42
2U	404-620	£3.82
3U	404-630	£4.16
4U	404-640	£4.58

MDF Unpainted Rack Cabinets

This series' surface is unfinished and ready for spraying or painting.

- Unpainted as many corporate users prefer their equipment housings to be finished in their own colours
- Complete with dowels and corner brackets to increase rigidity when no equipment is mounted
- Of the same measurements as those below
- Sliding shelf version not available



Trojan Rack Sleeves

Studio Rack Housings

Many studios prefer to use an attractive case like this product to house their equipment.

- These rack sleeves are based on our roadcases
- Fabricated from clear anodised aluminium extrusions and 9mm thick
- Plywood covered in a black vinyl surface
- Manufactured in accordance with ISO9001



Description	Code	Price (Ex VAT)
2U	458-410	£36.20
4U	458-420	£41.30
8U	458-430	£49.30
12U	458-440	£56.90
16U	458-450	£63.50

Professional Wall Cabinet

450mm

All units come with lockable front and side entry doors fitted with tempered glass to the British Standard and finished in a subtle shade of black.

- Rugged construction
- Panels bolted together
- With keys and 20 cage nuts



Description	Code	Price (Ex VAT)
Wall Cabinet 6U 450D x 530W	517-200	£ 76.50
Wall Cabinet 9U 450D x 530W	517-210	£ 93.40
Wall Cabinet 12U 450D x 530W	517-220	£ 114.20
Wall Cabinet 15U 600D x 530W	517-230	£ 126.70

Quickrack 8U and 16U

An updated cost effective racking system providing up to 8U or 16U of rack space.

- Side supports are slightly angled back at 5 degrees from vertical to counteract falling forward if knocked from the rear
- All holes are tapped M5 to save having to purchase caged nuts
- Includes 20 Black M5 equipment screws and plastic equipment protection washers



Description	Code	Price (Ex VAT)
QuickRack 8U (14 inch)	408-200	£19.80
QuickRack 16U (28 inch)	408-210	£26.40

Single Slide In Rack Strip

An aluminium extrusion that allows an M6 nut to be slid into whatever position is necessary.

- Mounting holes can easily be drilled through the flat part to secure the strip to a cabinet
- Length 1 metre

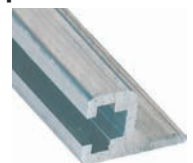

Description	Code	Price (Ex VAT)
Slide-in Rack	429-040	£4.80
Aluminium Slide-in nut	429-050	£0.35
Short Bolts	429-060	£0.35

ALL PRICES EXCLUSIVE OF VAT.

RACKS
Rack Hardware

RACKS

CONTINUED

Caged Nuts, Bolts and Washers

Packs of 10

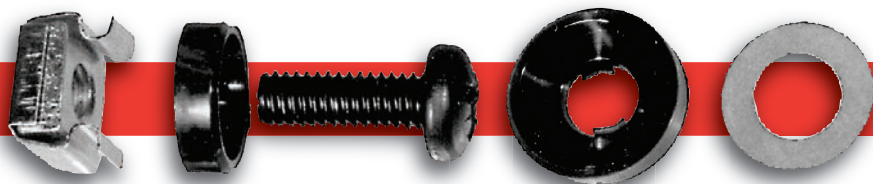

Description	Code	Price (Ex VAT)
M6 Screws x10	401-330	£2.19
M6 Caged Nuts x10	401-320	£2.19
Caged Nuts Deep x10	401-930	£2.65
Flat Washers x10	401-900	£1.25
M6 Washers x10	401-340	£1.45
Cup Washers x10	401-860	£2.19
Buster Caged Nuts each	900-070	£0.35
M5 Screws x20	440-440	£2.64

M6 Screws 16mm long cross head

Caged Nuts Two depths of caged nut: For steel rackstrip and sheet metal cabinets use **Normal** Caged Nuts.

For aluminium extrusions (thicker than steel strip), with square holes over 2mm deep use **Deep** Caged Nuts.

Flat Plastic Washers save fascias being marred.

Metal M6 Washers prevent the Plastic Washer turning when tightening.

Plastic Cup Washers.
NOTE. All the above are sold in packs of 10

Buster Caged Nuts suitable for Aluminium Extrusions Sold singly.

Humfrees Mk II

Stops rack mounted equipment creating earth loops through their metalwork. Stops hums and buzzes.

- Comprises 4 M6x16 bolts and 4 isolators
- OK for M5 racks. Just use M5 bolt
- Saves hours of investigative time



Description	Code	Price (Ex VAT)
Humfrees (4pk)	401-730	£4.99

Security Headed Rack Screws

Designed to deter the thief from removing equipment from racks.

- Head is domed so that it cannot be gripped with pliers
- Head has an Allen key hole but with a protruding centre pin that makes the insertion of a conventional key impossible
- Stainless Steel; Size M6 x 20mm long



Description	Code	Price (Ex VAT)
Security Bolt	401-880	£1.14
Allen Key	401-890	£5.47

Nylon M6 Rack Bolt

Nylon equipment Bolts are now a viable alternative to conventional metal types.

- More than adequate to support any equipment aside from heavy power amplifiers in transit
- Provide effective insulation should equipment need to be isolated from a rack's "earth"
- Colour Black.
- Length 16mm long



Description	Code	Price (Ex VAT)
M6 Rack Bolts Pack of 10	404-600	£1.97

RACKS
Rack Ventilation

Ventilation Panel



A 1U flat Ventilation Panel finished in Black epoxy resin.

- A necessity where equipment power is being dissipated in a confined space

Description	Code	Price (Ex VAT)
Ventilation Panel 1U	402-800	£10.87
Ventilation Panel 2U	402-810	£13.04

Perforated Ventilation Panel



For increased rigidity top and bottom edges are flanged.

- 68% of the fascia is open for ventilation. Finished in Black.

Description	Code	Price (Ex VAT)
Ventilation Panel 1U	460-170	£6.20
Ventilation Panel 2U	460-180	£7.50
Ventilation Panel 3U	460-190	£8.70
Ventilation Panel 4U	460-200	£9.90

1000s
of products
Available from stock!

RACKS
Rack Panels

19 inch Blank Panels



Studiospares Blank Panels.

- The Black versions are of aluminium and painted Black
- End fixing holes elongated and locate with standard fixing holes
- Thickness 3mm

Description	Code	Price (Ex VAT)
Black 1U	402-410	£6.84
Black 2U	402-420	£8.64
Black 3U	402-430	£11.68
Black 4U	402-440	£13.12
Black 5U	402-450	£16.36

12 Way D Type Universal Through Panels

A dual 1U Panel assembly drilled with 12 D type cut outs in the front and rear panels.

- Space between front and rear panels 80mm so allows plenty of space for wiring
- Includes a 10mm lip top and bottom to retain rigidity
- Finished in Black epoxy resin



Description	Code	Price (Ex VAT)
12way Thru Panel	548-880	£19.60

16 Way D Type Universal Blank Panel

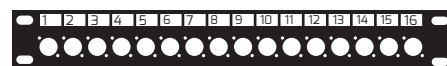

A 1U Panel drilled with 16 D type cut outs.

- Includes a 20mm lip top and bottom to retain rigidity
- Finished in Black epoxy resin and silk screened with channel identifications

Description	Code	Price (Ex VAT)
16 Way Panel	405-620	£11.58

Pre Drilled Blank Panels 1U and 2U

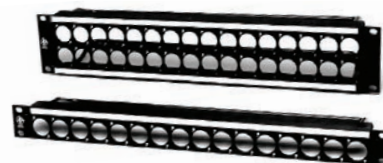

These blank panels are based on U shaped aluminium extrusions drilled to accept 16 Neutrik D series connectors.

- Available in 1U of space or 32 connectors in 2U of rack space
- 1U version includes a slide in designation strip above the cut outs
- 2U version two strips, one above and one below the cut outs
- Rear of the extrusion has mounting provision for a lacing bar. Two for the 2U version

Description	Code	Price (Ex VAT)
1U Panel	403-220	£34.20
2U Panel	403-190	£43.50
Lacing Bar	403-200	£13.75

MORE PRODUCTS
online

RACKS
Rack Trays

Securerack

A popular method of securing free standing equipment into a Rack Tray.

- Two Over Bars hold equipment in place
- Rear bar swivels to limit rear movement
- Max equipment width 429mm
- Tray depth 300mm
- Black powder coat finish



NEW LOWER PRICE

Description	Code	Price (Ex VAT)
Securerack 2U	406-121	£15.75
Securerack 3U	406-131	£18.25
Securerack 4U	406-141	£20.75

Sliding Shelf or Rack Drawer

A 1U Rack Drawer or if turned upside down a Sliding Shelf.

- 380mm deep
- Tray fully accessible when opened
- Front and rear mounting options
- Manufactured from 1.2mm steel
- Colour Black



Description	Code	Price (Ex VAT)
Rack Shelf/Drawer	429-010	£22.80

Sliding Universal Rack Tray

A well thought out 1U Sliding Rack Tray.

- Diagonal slots located such that screws can pass through the Rack Tray's slots to a suitable hole in the underside of the equipment
- Front and rear mounting options
- Manufactured from 1.2mm steel
- Depth 375mm, Width 410mm
- Front and rear Rack Ears adjustable between 360mm and 525mm



Description	Code	Price (Ex VAT)
Rack Tray 1U	429-000	£20.70

Rack Trays

294mm Deep

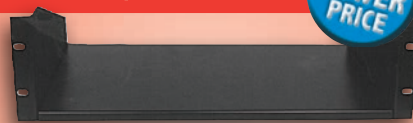

NEW LOWER PRICE

2U, 3U and 4U high Rack Trays with three piece construction...

Sides attach to base tray by 3 x M4 screws, (included) screwed into hank bushes. If equipment is tight for space, simply slacken screws until equipment can be positioned in tray, then tighten screws. Tray only can be inverted to provide additional 13mm extra usable height. **Much greater rigidity than El Cheepo 'one piece' constructed versions.** Finished in Black epoxy resin. They are able to support up to 20kg evenly distributed. **Note.** Most Cassette Recorders and CD players are 3U High.

1U Rack Tray - Special Note

Due to space limitations the 1U tray is a one piece design. Inside measurements 441mm Wide x 150mm Deep.

Description	Code	Price (Ex VAT)
2U	401-350	£18.75
3U	401-211	£20.79
4U	401-390	£23.75
1U	408-890	£12.34

RACKS
Drawer Units

Rack Mounted Drawer Units

A Rack Mounted Drawer Unit extends smoothly on ball bearing runners.

Provides 235mm of access. The drawer snaps shut and can then be locked with a key. Finished in a scratch retardant matte. Black epoxy coating.



NEW LOWER PRICE

Quantity discounts available

Manufactured in accordance with ISO9001 QC.

STUDIOSPARES

Description	Code	Price (Ex VAT)
1U	402-751	£34.42
2U	402-761	£37.92
3U	402-771	£41.63
4U	402-971	£49.80

RACKS
Rack Mounted Microphone Drawer 6U

Can be detached from the runners by depressing side catches.

- Recedes into a sleeve and is held closed by a slam latch
- An Optional Keylock
- Optional Foam Block allows mics to fit snugly into its own foam tube
- Black leatherette epoxy surface finish



NEW LOWER PRICE

Description	Code	Price (Ex VAT)
Microphone Drawer	406-411	£40.83
Foam Block	406-420	£29.17
Keylock	404-250	£12.60

RACKS
Rack Lighting

Dual Rack Lighting Bar

Features two flexible gooseneck lamps on a 19" rack mounting.

- Adjustable light intensity
- Fitted Lamp
- Mains adaptor is also included



Description	Code	Price (Ex VAT)
Dual Rack Bar	475-820	£39.70
Spare Lamp 475820	475-830	£1.25

Littlite Gooseneck Lights

The range is based on either a miniature high intensity quartz Halogen lamp or cool running LEDs mounted on an 18 inch (45cm) gooseneck. There are various models which only vary in their method of mounting the gooseneck. Bulb 12 volts at 300mA. Power supply is a separate item.

L3 Series Standalone System

Secured to a base unit which houses a dimmer and off switch.

- Termination by 1.75m of cable



Lamp and A BNC Connector

12" Gooseneck mounted on a BNC plug. (Used on Mackie mixers). Normal intensity lamp.

Description	Code	Price (Ex VAT)
L3 System	404-040	£39.30
Lamp on BNC Connector	404-940	£23.80
LPS-10VA-T AC Power Supply	405-490	£20.90
Q5 Spare High Intensity Bulb	510-010	£9.30

RACKS
Rack Security

Plexiglass Security Cover

Keeps equipment visible yet secure.

- Consists of a steel frame surrounding a lockable 4.7mm smoked grey plexiglass cover
- Depth between cover and equipment a minimum of 3.7mm
- We suggest the frame be attached to the rack with security bolts (Code 401-880) and special allen key (Code 401-890)



Description	Code	Price (Ex VAT)
2U	460-100	£36.50
4U	460-110	£45.20

Perforated Security Cover

These sturdy security covers protect your rack mounted electronics from tampering.

- 25mm deep so will also cover any knobs, meters etc.
- Cover screws can be removed whilst equipment is still retained by two screws

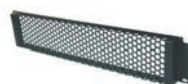

Description	Code	Price (Ex VAT)
1U	460-130	£18.95
2U	460-140	£20.50
3U	460-150	£21.95

WANT a job?

Are you looking for a stable and rewarding career?

Studiospares are constantly expanding. We require additional staff for a variety of positions, working in a very congenial atmosphere. Practical experience of recording and/or live sound engineering would be preferable.

send in your CV in the first instance

RACKS
Rack Lighting

RACKS

CONTINUED

Studiospares CP8+1

Clean Power Supply Racklight

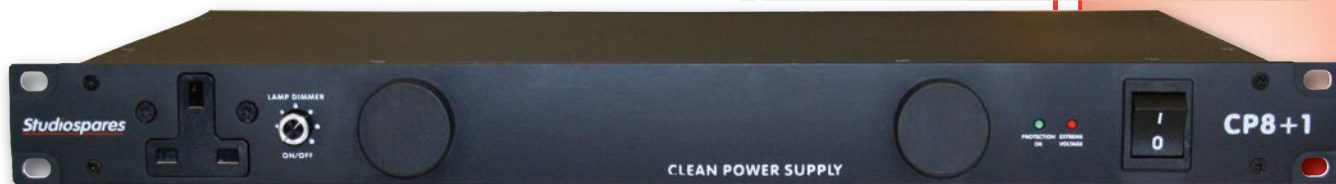

Mains-borne interference is frequently referred to as the silent killer. It can corrupt the CPU of digital workstations, take out hard drives and cause havoc with electronic kit that has amplification. Switching on fluorescent lighting can send a huge spike down the mains supply. The CP8+1 provides highly sophisticated multistage surge and spike protection with a response time of 1 nanosecond (0.000 000 001 seconds). The front panel houses the two retractable and dimmable illumination lamps and a spare 13amp socket. LEDs indicate Protection On and Extreme Voltage. The rear panel includes four 13amp UK sockets plus four IEC Equipment sockets. The BNC socket provides for a gooseneck lamp to illuminate the rear of the equipment rack, this has its own on-off switch. This unit is re-badged under various names and is normally sold at double or treble our price.

Description	Code	Price (Ex VAT)
CP8+1	348-160	1+ £74.17 2+ £69.50

STUDIOSPARES

Clean Power and Racklight...



Lamp tubes shown extended

Stageline GNL-214

BNC LED Gooseneck Light

Gooseneck Lamp for illuminating mixers from a BNC socket.

- Economy version, low power consumption
- 4x White LEDs, high intensity
- Wide angle beam
- Length 30 cm
- 12v 35mA



Stageline GNL-314

XLR LED Gooseneck Light

Gooseneck Lamp for illuminating mixers from a XLR socket.

- Economy version, low power consumption
- 4x White LEDs, high intensity
- Wide angle beam
- Length 40 cm
- 12v 35mA



Description	Code	Price (Ex VAT)
GNL-214	255-860	£12.40
GNL-314	255-870	£12.40

Rack-Mounted Gooseneck Lamps x2

Features 2 Gooseneck lamps emerging from a 1U rack-mount.

- Attractive Black finish
- Gooseneck lengths are both 30cm, giving maximum flexibility
- Anti-dazzling illumination through the use of matte moderating glass
- Power supply included.
- LED lamp (not standard)



Description	Code	Price (Ex VAT)
Goosenecks Lamps x2	450-820	£58.70

Adam Hall Coollight

19" 1U White Racklight

Provides a diffused focussed light source which stretches almost the full rack width.

- Stops glare and is heat free
- Throws a beam across 20U of rack space, and looks stunning
- The unique design of the UV resistant acrylic light guide provides cool concentrated light with no hot bulbs
- Choose between 2 different brightness settings



NEW

Description	Code	Price (Ex VAT)
Coollight White	403-400	£29.00
Coollight Indigo Blue	403-430	£29.00

Jack Patch Panels

RACKS

Behringer Ultrapatch Pro PX3000

3-mode multi-functional 48-point balanced patchbay with fully balanced, TRS connectors.

- Normal, Half-normal and Thru function modes
- NORMAL interconnects the two rear Jacks of one channel
- THRU interconnects each rear Jack with its corresponding front Jack
- HALF NORMAL interconnects the two rear Jacks of one channel
- Inserting a plug into one of the front or lower Jacks interrupts the connection of the rear Jacks

Description	Code	Price (Ex VAT)
PX3000	380-260	£45.83

Studiospares SS48

48 Way Enhanced Patch Bay

This innovative range provides users with a professional product at a sensible price. From the front all three versions are identical and are supplied normalised. The differences relate to the method of termination at the rear.

SS48J Jack Socket

Individual channels may be unnormalised by simply unscrewing that channel's rear securing nut and turning the PCB through 180 degrees and replacing the nut. It is also easy to reconfigure when more gear is brought into the patching system. It can be used on both Balanced and Unbalanced systems.



Side/Rear view of SS48J version

SS48P Phono Socket

The relatively large contact area of Phono plugs make them suitable for situations where they remain undisturbed for long periods. This version, the SS48P is supplied normalised and can be unnormalised by simply unplugging a small jumper plug.

SS48H Hard Wired

For absolute reliability, the hard wired version the SS48H is the most appropriate. This version can be unnormalised by unplugging a jumper plug.

Description	Code	Price (Ex VAT)
SS48J	401-170	£69.37
SS48P	405-520	£75.00
SS48H	405-540	£81.50

SATURDAY DELIVERY
no problem

Neutrik NYS-SPP-L1

48 Way 1/4" Patch Bay

Neutrik are easily number one in audio connector technology.

The NYS-SPP-L1 will consolidate that lead. It is well engineered and includes screening round most of the internal sockets and circuitry.

Each channel consists of a block of four sockets which are held in place by a metal bracket. Two sockets protrude through the front panel and two through the rear. By turning the assembly by 180 degrees individual channels can be configured half-normalised or isolated. The NYS-SPP-L1 is supplied with all channels half normalised. In that position the lower front panel socket will be Grey. The earthing can be disconnected on each channel. Channels are numbered 1-24 (front and back) and a designation strip runs above the upper row and another below the bottom row.



Description	Code	Price (Ex VAT)
NYS-SPP-L1	440-910	£41.50



Samson S Patch Plus



Fully balanced and extremely durable, this Samson 48-point patch bay makes all your connections easy.

- Normal, Half-normal and Through Mode operation via 3-way Front Panel Mode Switches
- 1/4" Stereo or Mono Jack Connectors and 19" Rack Mount Chassis

Description	Code	Price (Ex VAT)
S Patch Plus	368-580	£91.66

Jackfield Burnishers Bantam and Jack

The Jackfield Burnisher solves the problems of Patch Bay contacts becoming tarnished.

- The burnisher has the same profile as the plug
- Stainless steel body is chromium plated with a slightly abrasive finish
- Central hole passing the length of the burnisher connects with holes drilled crosswise near the tip



Description	Code	Price (Ex VAT)
Jack Socket Burnisher	402-940	£18.95
Bantam Plug Burnisher	402-930	£18.95

RACKS

Bantam Patch Panels

Switchcraft TT96

Bantam Patch Panel

Developed to enable users to connect more plugs into a smaller area.



The smaller plug yields a small contact area compared with the standard Jack. Therefore contact reliability is crucial. Switchcraft have long been the manufacturer others seek to emulate. Like all true American products, they are of substantial construction and totally reliable. They continue their tradition of using the long frame with the long nickel silver spring tempered spring contacts which by virtue of their length are more tolerant to minor differences in plug dimensions. The bushing is nickel plated brass. The new TT96 is based on an attractive black anodised aluminium panel which features extra wide rigid vinylite labelling strips which simply slide in and click in place under a transparent moulded plastic strip. (Others accidentally slide out). The nickel plated cold rolled tie bar is integral. The TT96 is supplied complete with full normalising contacts which are fanned for ease of soldering whilst the earth terminal is offset for ease of making common ground bus connections. The switching contacts are welded, gold alloy inlaid over a palladium base. No expense is spared.

Description	Code	Price (Ex VAT)
TT96	403-170	£222.50



Universal Patch Bay Lacing/Tie Bar

This ingenious design can be used in conjunction with any 1U Patch Bay.

- Provides safe anchorage and support for wiring looms
- Takes the strain off the rear terminals/plugs and associated wiring
- Plenty of adjustment for any situation
- A must for every Patch Bay



Description	Code	Price (Ex VAT)
ISO Lacing Bar	401-230	£8.29

VISIT
our trade counter
You'll get friendly advice and immediate access to 8000+ product lines!

MORE PRODUCTS
online

RACKS

Speaker Patch Panels

Speaker Panel



A quick and easy way to manage Speaker distribution.

- A 1U high panel with 12 twist n lock speaker connectors
- Rear connection by solder tags

Description	Code	Price (Ex VAT)
Speaker Panel	448-800	£29.70

WHAT is normalising?

Most patch panels are supplied with all sockets isolated (not normalised). In this case, the only internal linking is between the front sockets and rear terminations. Normalising is a means of establishing a connection between top and bottom sockets without a patch lead. This is useful when sockets which are normally connected together, such as mixer insert points, are brought up to a patch panel.

There are two methods of normalising in common use: half normalising (or semi normalising) and full normalising. When a pair of sockets is half normalised (sometimes called sniff and break), the link between them is broken only when a plug is inserted into the bottom socket. The top socket can be plugged into without breaking the link. If a pair of sockets is fully normalised, the link is broken when a plug is inserted into either the top or bottom socket.

If you need more information, please contact our technical sales team, who will be glad to help further.

RACKS

XLR Patch Panels

XLR Rack Panels



12 XLR male or female sockets pre mounted on a Black 1U steel panel.

- Uses die cast chassis XLRs with nickel on copper plated contacts
- Should last a lifetime
- All sockets are numbered

Description	Code	Price (Ex VAT)
Male XLR Rack	448-560	£19.82
Male XLR Female	448-570	£15.66

Art P16

16-Channel Balanced XLR Patch Bay



Saves wear and tear on the connectors of expensive audio equipment by bringing all commonly used connections to this external patch bay.

- 1/4" TRS connectors
- High quality passive interface
- XLR connectors (female on front, male on rear)
- 1U-high with rugged, fully shielded black all-steel enclosure

Description	Code	Price (Ex VAT)
P 16	325-900	£65.50

ALL PRICES EXCLUSIVE OF VAT.

Universal Patch Panels

RACKS

16 Way D Type Universal Blank Panel



A 1U Panel drilled with 16 D type cut outs.

- Includes a 20mm lip top and bottom to retain rigidity
- Finished in Black epoxy resin and silk screened with channel identifications

Description	Code	Price (Ex VAT)
16 Way Panel	405-620	£11.58

Signex Universal Panel 16 Way



Can be fitted with any combination of connectors conforming to the Neutrik D' series pattern as listed below.

- No fixings are visible from the front as the modules are retained by two screws at the rear
- Visually harmonised design matches other panels in the Signex 'CP' series
- A lacing bar should be used, as there is no other means of strain-relief for the solder joints

Description	Code	Price (Ex VAT)
16way empty panel	405-750	£31.40
Blanking plate x4	440-370	£4.44
XLR 3pin female metal	577-760	£3.51
XLR 3pin male metal	577-770	£3.41
XLR 3pin female	568-020	£0.99
Jack Type A 2/3 pole	440-380	£3.96
DIN/MIDI	440-390	£6.92
Gold Phono	440-400	£3.47
BNC-BNC	440-410	£3.98
TOS Link Optical Couplers	900-022	£7.47
NE8FDP Chassis Ethercon	581-330	£7.47
NL2MP Speakon 2 Pin	578-590	£1.77
Signex Lacing Bar Kit	401-230	£8.29

WANT a job?

Are you looking for a stable and rewarding career?

Studiospares are constantly expanding. We require additional staff for a variety of positions, working in a very congenial atmosphere. Practical experience of recording and/or live sound engineering would be preferable.

send in your CV in the first instance

FOR fax orders

Use our fax number...

020 8450 4390

Wall Panels

RACKS

Wall Panels

A useful series of loaded wall panels that fit in standard UK wall boxes/Light switch boxes.

- All connectors are highly reliable
- Sold as separate items on our connectors pages
- Plate is of stainless steel



Description	Code	Price (Ex VAT)
XLR Female x1	548-760	£6.49
XLR Male x1	548-770	£6.49
Locking Jack Socket x1	548-780	£7.15
Speakloc Socket x1	548-790	£6.65
XLR Female x2	548-800	£7.29
XLR Male x2	548-810	£7.29
XLR Female + XLR Male	548-820	£7.29
Locking Jack Socket x2	548-830	£8.15
Speakloc Socket x2	548-840	£7.55
BNC Socket x1	548-850	£6.49
BNC Socket x2	548-860	£7.29
Phono Socket x1	548-870	£7.29
Minijack Socket 3.5mm x1	548-890	£7.29

Fuses

RACKS

Quick Blow and Anti-Surge Fuses

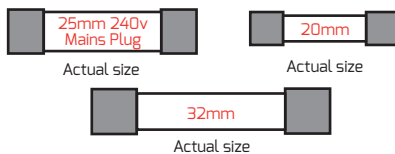

QUICK BLOW			
20mm		32mm	
100mA	520-010	100mA	532-010
200mA	520-020	200mA	532-020
315mA	520-030	350mA	532-030
400mA	520-040	500mA	532-040
500mA	520-050	630mA	532-050
600mA	520-060	800mA	532-060
800mA	520-070	1amp	532-070
1amp	520-080	2amp	532-080
2amp	520-090	3amp	532-090
3amp	520-100	5amp	532-100
4amp	520-110	10amp	532-110
6.3amp	520-120	20amp	532-120
10amp	520-130		
20amp	520-150		
ANTI-SURGE			
20mm		32mm	
200mA	520-170	200mA	532-140
315mA	520-180	350mA	532-150
400mA	520-190	500mA	532-160
500mA	520-200	630mA	532-170
600mA	520-210	750mA	532-180
800mA	520-220	1amp	532-190
1amp	520-230	2amp	532-200
3amp	520-250	3amp	532-210
5amp	520-260	5amp	532-230
6.3amp	520-270		
7.5amp	520-280		
MAINS PLUG FUSES			
3amp	521-030	13amp	521-130
Description	Code	Price (Ex VAT)	
All Quick Blow	-	£0.19	
All Anti-Surge	-	£0.31	
All Mains Plug Fuses	-	£0.17	

WHICH fuse to use?

Anti Surge. To charge up large power supply capacitors fuses may have to withstand up to ten times normal rating when equipment is first turned on. Such fuses will generally be between the mains input and the DC output of the rectifier circuit. They can usually be identified by an internal spring or blob of solder on the fuse wire.

Quick Blow. Generally used to isolate faults within individual circuits, eg Tape transport or pre amplifier electronics. Identified by a straight piece of fuse wire.

Mains Plug. Opaque body to absorb flash when blowing 25mm long.

Fuse rating. Marked on existing fuse. If in doubt, mains fuses are usually designed to blow if current is 1.5 times normal value. Check equipment power rating. For every 250 watts, 1 amp is consumed.

If you need more information, please contact our technical sales team, who will be glad to help further.

Velcro Hook and Loop Tape

SERVICE

Velcro® Hook and Loop Tape

Self Adhesive

The original and the best Hook and Loop tape. Rubber and resin pressure sensitive backing.

- 2 Loop colour options
- OK for 5000 attach/peel off cycles
- Thickness when closed 3mm
- Adhesive holds spec 0 - 30 deg C
- Made from Nylon 66 for max durability
- Resistant to water, salt & weak acids



HOOK



LOOP

Description	Code	Price (Ex VAT)
Hook Black 15mm	538-110	£0.77
Hook Black 25mm	538-120	£1.03
Loop Black 15mm	538-130	£0.77
Loop Black 25mm	538-140	£1.03
Loop Red 15mm	538-150	£0.77

SERVICE

Adhesive Tapes

Heat Shrinkable Tape

Combines the advantages of heat shrinkable sleeving having the ability to be wrapped around irregular shapes and profiles.

- As the tape is wrapped around the component it will lightly adhere to itself
- Heat is then applied and the tape will shrink and present a fully moulded appearance
- Handy tip:** To initiate shrinkage moisten (spit on) the last full turn of tape
- Best results are at a temperature of 130 deg C
- Operating temperature -55 deg C to 105 deg C.
- Width 19mm. Reel length 50m



Description	Code	Price (Ex VAT)
Heat Shrinkable Tape	538-010	£7.96

DELIVERY BEFORE NOON
no problem

Gaffer Tape

Black/Silver/White

A plastic/cloth composition with great strength and adhesion properties

Black, Silver and White. Length 50 metres. Width 2" (50mm).

Description	Code	Price (Ex VAT)
Black	126-620	£4.99
Silver	126-630	£4.99
White	126-640	£4.99
Black 24-Pack	126-624	£102.50



This HI TAK version has even greater ability to get a strong purchase on previously difficult surfaces.

Gaffer Tape Premium

Premium quality ultra strong gaffer tape available in 3 different colours.

- 50mm x 50m
- Easily tearable
- Water resistant
- High strength adhesive
- Extremely durable
- 50 Mesh



Description	Code	Price (Ex VAT)
Gaffa Tape Premium Black	126-590	£8.32

Stage Performer Guiding Tape

A heavy grade striped PVC tape visible to performers on poorly lit stages.

- Striped Yellow/Black
- Often laid near edges or as a guiding path to a cue point on stage
- Heavy gauge which should not scuff when walked on
- 50mm wide

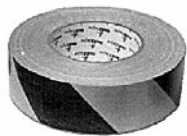

Description	Code	Price (Ex VAT)
Guiding Tape	126-530	£11.40

All Weather PVC Tape

An all weather PVC tape suitable for many users.

- Ideal for exterior electrical insulation where extreme temperatures are involved
- Tape thickness 0.19mm
- Length 33metres
- Width 19mm (0.75")
- Colour Black



Description	Code	Price (Ex VAT)
PVC Tape	535-770	£3.65

Masking Tape

Masking Tape 1" (25mm) wide.

- Creped paper self adhesive
- Finds many applications in Studios
- Particularly for marking and identification purposes



Description	Code	Price (Ex VAT)
Masking Tape	126-060	£2.09

Scribble Strip Console Tape

Brilliant for labelling permanently or temporarily on anything.

- Safe on practically all surfaces
- Easy to apply, easy to remove without leaving any residue. (Test with a small sample if in doubt)
- Width 19mm
- 50 long



Description	Code	Price (Ex VAT)
Console Tape	596-590	£14.20

Self-Amalgamating Tape

More convenient than heatshrink.

- Tape which flows into itself when stretched and wrapped round cables and pipes etc, to form a permanent waterproof seal
- Doesn't have to be stored in the fridge
- Roll length 10m
- Width 25mm
- Colour Black



Description	Code	Price (Ex VAT)
Self-amalgamating Tape	535-720	£6.55

CAUTION!

Please note that aerosols cannot now be sent by Royal Mail. Courier delivery only.

Airduster

Pure compressed gas.

- Moisture free and leaves no residue
- Contents 400mL



Description	Code	Price (Ex VAT)
Airduster	635-120	£13.28

Super Servisol

Effective switch and carbon track cleaning agent.

- Leaves a conducting oil film which also reduces the sliding contact resistance
- Contents 200mL



Description	Code	Price (Ex VAT)
Super Servisol	635-000	£2.96

Fospro

Multipurpose aerosol.

- Restores electrical conductivity, displaces moisture, lubricates and frees
- Contents 320mL



Description	Code	Price (Ex VAT)
Fospro	635-090	£7.95

Aero Klene

Precision cleaning agent for use on recorder heads, switches, dry relay contacts and printed circuit boards.

- Effective for cleaning faders but also dissolves any lubricants which should then be replaced.
- Contents 200mL



Description	Code	Price (Ex VAT)
Aero Klene	635-030	£5.52

Aerosols

SERVICE

Foam Cleanser

A special blend of chemicals that will remove grease and grime from equipment.

- It is a mixture of solvents and detergents with anti-static properties
- Contents 400mL



Description	Code	Price (Ex VAT)
Foam Cleanser	635-080	£4.16

Adhesive Heavy Duty Spray 400ml

Suitable for applications where good initial strength is required.

- Effective on glass, rubber, wood, metals and most lightweight materials
- CFC free
- Sold loose



Description	Code	Price (Ex VAT)
Adhesive Spray 400ml	635-170	£6.50

Health & Safety

SERVICE

Microphone Spray

Microphone/Headphone Sanitizing Spray

Pumped in a measured dose of aerated foam applied with a cloth or hand which clings to the external microphone mesh.

- Antimicrobial cleaning fluid
- Foam does not touch the internal electronics
- Foam dissipates within two minutes
- Effective alcohol free formula and foam aeration system
- No more fear of infection
- 50mL bottle provides approx 100 applications



Microphone Kit

Includes a 50mL spray, soft nylon scouring pad, cleaning brush, micro fibre cleaning cloth and a Black zipper case.

Description	Code	Price (Ex VAT)
Sanitizing Spray	635-540	£9.95
Sanitizing Kit	635-550	£19.95

DELIVERY BEFORE 10AM
no problem

Batteries

SERVICE

Duracell Industrial

Batteries

Designed exclusively for professional users.

Providing high quantities of dependable batteries at a cost-effective price, Industrial by Duracell batteries are designed and manufactured to meet IEC 60086 and ISO 9000 standards. Delivering long-lasting power across a range of professional applications and capable of operating in temperatures from -20°C to 54°C. Reliable performance, even after seven years of storage. Bulk battery for use in torches, smoke alarms and medical devices.



AAA	HP16	MN2400	1175mA/H
AA	HP7	MN1500	2700mA/H
C	HP11	MN1400	7750mA/H
D	HP2	MN1300	18000mA/H
9volt PP3	PP3	MN1604	550mA/H

Description	Code	Price (Ex VAT)
AAA Industrial x1	635-560	£0.62
AAA Industrial 10-Pack	635-561	£4.92
AAA Industrial 100-Pack	635-562	£41.58
AA Industrial x1	635-570	£0.62
AA Industrial 10-Pack	635-571	£4.92
AA Industrial 100-Pack	635-572	£41.58
C Industrial x1	635-580	£0.83
D Industrial x1	635-590	£1.16
PP3 Industrial x1	635-600	£1.66

Maxell AA/AAA

16-Pack Batteries

Recommended for Low/Constant drain devices including Smoke Detectors, Clocks, Remote Controls and other applications.

- Long-life Alkaline batteries for common equipment
- The most popular types of batteries
- Recommended for low energy/constant use devices
- Expiry date shown on battery pack
- A member of the REPIC eBATT Compliance scheme



Description	Code	Price (Ex VAT)
AA 16-Pack	603-010	£4.16
AAA 16-Pack	603-000	£4.16

Sound Level Meters

SERVICE

Monacor SM-2

Sound Level Meter

The electronics feature A and C weighting, slow and fast, max hold and data hold.

- Frequency range 31.5-8,000Hz
- Measuring range, low 35-100dB
- Measuring range, high 65-130dB
- Resolution 0.1dB
- Accuracy±1.5dB (94dB/1kHz)



Description	Code	Price (Ex VAT)
SM-2	745-150	£73.30

Multimeters

SERVICE

Digital Multimeter

A good low cost Digital Multimeter with 3 1/2 digit 0.5inch display with negative polarity indication and overrange display.

- DC voltage ranges 0.1mV to 1000V
- AC 0.1 volts to 750 volts
- DC current 0.1µamp to 10 amps
- Resistance from 0.1Ω to 2MΩ
- The Diode Test is 2.8 volts at 3mA
- Battery life about 2000 hours



Description	Code	Price (Ex VAT)
Digital Multimeter	745-130	£9.85

Illuminated Signs

SERVICE

On Air Sign

Illuminated Acrylic Sign



Avoid retakes! Alleviates colleagues walking in to a recording studio and causing havoc.

- Artwork etched into acrylic so will never fade
- Mains powered 240 volts
- Complete with hanging chain
- Runs cool unlike some light box signs
- Supplied with 1m of cable and no mains plug.
- No switch. Just turn on the electricity.

Description	Code	Price (Ex VAT)
ON AIR Sign	403-930	£37.50

Sonifex LED LD-20F1MCL

NEW

Mic Live Sign

Designed for outside recording, on-air and production studios, meeting rooms, conference rooms and for fixed installations.

- Input 5-7V DC on 4way screw terminals
- Control 2x pull down to 0V
- Dimensions 200mmW x 80mmH
- Illuminated RGB LED sign
- Can be simply configured onsite for your particular requirements



Description	Code	Price (Ex VAT)
LD-20F1MCL	368-310	£124.95

Cable Testers

SERVICE

Studiospares Roadie Toolkit

Carrying Case

A new package deal, ideal for roadies and engineers.

- Contains our well regarded cable tester (including battery), an XLR lead, and some useful connectors and adaptors
- Comfortable carrying handle
- Locking catches. Internally lined
- Effective seal against moisture and dust etc
- Dimensions external 426mmW x 285mmD x 165mmH



Description	Code	Price (Ex VAT)
Roadie Toolkit	458-290	£41.58

Behringer CT100

Cable Tester

Intelligent, CPU-controlled tester...

- Intelligent, CPU-controlled tester
- Tests XLR, mono and stereo jacks, phono and MIDI cables
- LED display shows which input pin is connected to which output pin
- Separate shield and phantom power LEDs
- Installed cable test mode
- Test tone generator operating at 1kHz and 440Hz
- Requires two AA batteries



Description	Code	Price (Ex VAT)
CT100	370-030	£20.82

Palmer/Adam Hall Cable Tester

Multipurpose

Covers XLR, Jack, Phono, DIN/MIDI and Speakons in any combination.

- Test Procedures provide status on proper connections for open circuits, short circuits, reverse polarity, shorts between cold and ground and even battery status
- The unit is well constructed and covers practically every eventuality.



Description	Code	Price (Ex VAT)
Palmer Cable Tester	535-820	£56.50

FREE catalogue

Are you reading someone else's catalogue? Why not call us and order your own copy...

it's free!

1000s of products Available from stock!

DELIVERY BEFORE NOON no problem

Studiospares Ultimate Cable Tester

With Tester Case

Easily the most relevant cable tester for the Pro Audio Industry.

The Ultimate Cable Tester covers the following: XLR 3 and 5 pin, Jack, Mini Jack, Phono, DIN/IEC 3, 5, 7 and 8 pin, Speakon/Speakloc 2, 4, and 8 pin and Cat 5. LEDs confirm continuity and phase connection. Also indicates ground to shell short circuit. Complete with probes and battery. All metal construction.

Dimensions - 40mm height x 88mm width x 188mm depth. All metal padded case with latch. Space for probes. Dims mm 207 x 159 x 77.

An essential piece of kit for every engineer.



	UCT100	UCT50	UCT100U	UCT100M
XLR 3 pin female	✓	✓	✓	✓
XLR 5 pin female	✓		✓	✓
XLR 3 pin male	✓	✓	✓	✓
XLR 5 pin male	✓		✓	✓
Jack Unbalanced	✓	✓	✓	✓
Jack Balanced	✓	✓	✓	✓
Mini Jack 3.5mm	✓			✓
Phono (RCA)	✓	✓	✓	✓
Speakon/Speakloc 4 way	✓	✓	✓	✓
Speakon/Speakloc 8 way	✓	✓	✓	✓
Banana Speaker	✓	✓	✓	✓
Small DIN				✓
MIDI	✓	✓	✓	✓
MIDI/DIN 3 5 7 8 pin	✓	✓	✓	✓
USB			✓	
Cat 5	✓		✓	
Phase testing	✓	✓	✓	✓
Continuity probes	✓	✓	✓	✓
Battery	✓	✓	✓	✓

Description	Code	Price (Ex VAT)
Ultimate Cable Tester	458-260	£20.83
All Metal Tester Case	458-550	£11.70
Cable Tester + Case	458-265	£28.33
UCT50	458-830	£16.70
UCT100M	458-840	£25.50
UCT100U	458-850	£25.50



Cable Tester + Case



UCT50



UCT100

MORE PRODUCTS online

SATURDAY DELIVERY no problem

DELIVERY BEFORE 10AM no problem

ALL PRICES EXCLUSIVE OF VAT.

Specialised Hand Tools

SERVICE

Wire Cutters

Precision ground cutting edges are induction hardened to 56HRC.

- Zero play joint has a high grade steel rivet to give easy action on repetitive operations
- Manufactured from INOX stainless steel
- Cushion grip spring loaded handles
- High precision at a modest price



Description	Code	Price (Ex VAT)
Wire Cutters	536-080	£15.60

Snipe Pliers 4.5"

Sub Miniature Pliers.

- Flat serrated jaws
- Yellow insulated handles



Description	Code	Price (Ex VAT)
Snipe Pliers 4.5"	535-240	£6.35

Small Vice

Aluminium alloy Vice with screw clamp for easy fixing to bench tops.

- Fits bench tops up to 30mm thick
- Vice jaws open to 50mm
- Jaw width 60mm
- Durable construction
- Finished in Grey Hammerite coating



Description	Code	Price (Ex VAT)
Small Vice	404-800	£11.40

Auto Wire Stripper + Cutter

Makes light work of removing insulation and sheaths.

- Squeezing the handles first closes the gripping jaws
- Two parallel cutters slice into the insulation and pull it clear
- Can be set between 0.5mm-8mm
- Separate cutters for cutting right through cable



Description	Code	Price (Ex VAT)
Auto Wire Stripper + Cutter	536-160	£6.30

Draper 225mm Capacity Caulking Gun

Pressed steel frame and handle.

- Compatible with most manufacturers 310ml sealant dispensers
- Length 280mm
- Max tube length 225mm



Description	Code	Price (Ex VAT)
Caulking Gun	635-320	£2.66

Allen Keys

95% of all equipment now uses metric threaded screws.

- This set of eight Allen Keys covers all sizes from 1.5mm to 6mm
- Key holder reveals if any keys are misplaced



Description	Code	Price (Ex VAT)
Allen Keys	536-270	£3.25

Automatic Cable Strippers

Heavy Duty

Enables sheath and screening or just sheath to be removed with a "one squeeze" operation.

- Once the cutting action is completed the blades pull the unwanted parts away
- Provides four cutting diameters (1mm, 1.6mm, 2mm, 3.2mm)
- The length of the insulation to be removed can also be set
- Makes stripping almost too easy



Description	Code	Price (Ex VAT)
Auto Cable Strippers	536-130	£16.92
Spare Blades	536-140	£5.20

Jeweller's Screwdriver Set

A useful set of hardened tools with steel precision ground blades.

- Screwdriver body of nickel plated steel
- Three cross head blades sizes 00, 0 and 1 plus three slotted heads 1mm, 1.4mm and 2mm
- An invaluable bench tool



Description	Code	Price (Ex VAT)
Screwdriver Set	536-280	£3.55

Soldering Equipment

SERVICE

Draper Asbestos-Free Soldering Mat

Guaranteed asbestos-free.

- Protects working areas from flame damage and scorching when soldering or using gas torches
- 250mm x 250mm



Description	Code	Price (Ex VAT)
Soldering Mat	635-370	£4.64

Hands Free Component Holder

Well engineered device which allows hands free soldering of components and PCBs.

- Six ball joints allow adjustment to the exact angle
- This version includes a magnifying glass
- Heavy iron base prevents tipping and provides stability



Description	Code	Price (Ex VAT)
Component Holder	537-700	£9.95

Antex 25 Watt Mains Soldering Iron

A powerful 25 watt Antex Soldering Iron that can muscle sufficient heat when the need demands.

- Particularly useful when soldering larger objects and surfaces
- Hanging hook
- Fitted with a Long Life 3mm bit

Description	Code	Price (Ex VAT)
25W Mains Iron	535-920	£18.30
Optional Spare Long Life Bit	535-930	£3.69

Soldering Station

A professional quality Soldering Station.

- Full temperature control which can be set in the range 150-480°
- Tip grounded to protect sensitive ICs and semi conductors
- Reaches full working temperature within 1 minute
- Includes holder and sponge



Description	Code	Price (Ex VAT)
Soldering Station	535-940	£59.20

Solder Fume Extractor

Removes solder fumes via an activated carbon filter in conjunction with a high performance fan.

- Can significantly reduce headaches, eye irritation and nausea
- Adjustable angle for accurate placement
- Power consumption: 23W
- Dimensions: 222(w) x 270(h) x 168(d) mm
- Weight: 1400g
- Replacement activated carbon filter also available



Description	Code	Price (Ex VAT)
Solder Fume Extractor	603-020	£39.90
Solder Extractor Filter	603-030	£6.50

Lead Free Solder

+ Accessories

Half Kilo Reel + Multicore Solder

- Diameter 1.2mm
- New legislation precludes the inclusion of lead in solder
- This is substituted for a tin/copper mix



Metal Soldering Iron Stand

- Supplied complete with sponge
- It will accept practically all soldering irons
- Avoids burnt carpets and benches

Description	Code	Price (Ex VAT)
Half Kilo Reel + Solder	536-070	£25.40
Soldering Iron Stand	536-040	£6.22
Spare Sponge	536-050	£1.24

Desoldering Pump



Solder Sucker.

- An essential instrument which sucks molten solder away from the joint
- Double O ring inside barrel for increased suction
- Easy to empty

Desoldering Braid

A simple and effective means of removing solder from plugs and PCBs.

- Heat the braid and excess solder will flow onto the braid



Description	Code	Price (Ex VAT)
Desoldering Pump	535-790	£4.42
Desoldering Brand	535-800	£1.45

SERVICE

Staging

Road Ready Intellistage

Portable Staging System

A lightweight and highly portable staging system which can be easily stored, transported and erected at short notice.



The system has two main components, a supporting spider leg assembly and a top panel, the stage. The stage locks to the legs on each corner. The spider leg system (Riser) is an ingenious mechanism consisting of nine telescopic legs interconnected in a manner similar to a spreading umbrella. Folded for transportation or storage, the height is at maximum, the spread apart is at a minimum. Unfolded the height is at a minimum but the legs are spread apart to form nine low supports covering a floor area of 1metre x 1 metre. To support the standard 2 metre x 1 metre stage use either two 1m x 1m risers or one 2m x 1m riser. Step Risers are 1m wide and in three different heights. The stage consists of a sandwich of plywood, honeycomb and more plywood 20.5mm thick. The stage has underside locating sockets which mate with short posts on top of the four corner pillars to stop the stage sliding off. Metal reinforced corners increase durability. Four different heights are available each using a dedicated leg assembly called Risers. For additional stability, adjacent leg assemblies are locked together by brackets, use ISSJ which contains 4 locking Riser Clamps. More complex platforms of four differing heights can be created. A triangular platform can be used as a hub with 2m x 1m or 1m x 1m stages fanning out. Quarter circle stages can lock onto rectangular or square staging, or a completely circular stage can be created. As an example a drummer could erect a 2m x 1m stage to raise him above other instrumentalists in a couple of minutes. Sections of an orchestra could also be elevated. Individual components are lightweight and easily transported. The stage surface has a similar finish to a carpet tile. The system is easily portable and therefore lightweight. In consequence it requires a degree of care when transporting, erecting and dismantling. Manufacturers quote 900kg/sq metre.

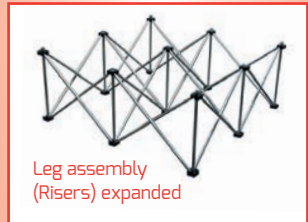

Description	Code	Price (Ex VAT)
Platform 1m x 1m	651-000	£109.70
Platform 2m x 1m	651-010	£169.00
Triangular 1m x 1m	651-020	£95.00
Quarter Round 1m	651-030	£97.00
Step Platform	651-040	£84.50
1m x 1m Riser 0.2m High	651-050	£85.00
1m x 1m Riser 0.3m High	651-060	£86.00
1m x 1m Riser 0.4m High	651-070	£88.00
1m x 1m Riser 0.6m High	651-080	£95.00
2m x 1m Riser 0.2m High	651-090	£132.00
2m x 1m Riser 0.3m High	651-100	£133.00
2m x 1m Riser 0.4m High	651-110	£136.00
2m x 1m Riser 0.6m High	651-120	£153.00
1m wide Step Riser 0.2m High	651-130	£51.00
1m wide Step Riser 0.3m High	651-140	£52.00

Description	Code	Price (Ex VAT)
1m wide Step Riser 0.4m High	651-150	£55.00
1m Triangular Riser 0.2m High	651-160	£27.00
1m Triangular Riser 0.3m High	651-170	£28.00
1m Triangular Riser 0.4m High	651-180	£29.00
1m Triangular Riser 0.6m High	651-190	£33.00
1m Qtr Round Riser 0.2m High	651-200	£60.00
1m Qtr Round Riser 0.3m High	651-210	£63.00
1m Qtr Round Riser 0.4m High	651-220	£69.00
1m Qtr Round Riser 0.6m High	651-230	£83.00
2m x 0.2m Black Skirts each	651-240	£41.00
2m x 0.3m Black Skirts each	651-250	£46.00
2m x 0.4m Black Skirts each	651-260	£50.00
2m x 0.6m Black Skirts each	651-270	£54.00
ISSI-4	651-280	£14.50

VISIT
our trade counter
You'll get friendly advice and immediate access to 8000+ product lines!
free parking for 40 cars

FOR
fax orders
Use our fax number...
020 8450 4390

THE
website
Keep up to date with all the latest products and current prices on the Studiospares website!
check out www.studiospares.com

ALL PRICES EXCLUSIVE OF VAT.

INDEX

Acoustics			
Isolation Rooms	298	Acoustic Tiles	307
Vocal Isolation Booths	300	Bass Traps	310
Drum Isolation Booths	300	Acoustic Room Kits	312
Speaker Sound Isolation	301	Acoustic Starter Kits	314
Floor Sound Isolation	302	Reflection Filters	314
Sound Screens	305	Sound Diffusors	316
Acoustic Panels	305	Acoustic Glues + Aerosols + Foams	316

ACOUSTICS

Isolation Rooms

Esmono Room

Sound Acoustic Isolation Room

Sound isolation rooms in use all over Europe!

Esmono rooms are based on standardised panels finished in White, made from metal 1.5mm thick. They are either 2.0m or 2.2m high and 800mm wide. They look stunning and have the performance to match. We also recommend the use of an internal floating floor to completely detach the goings on inside the booth from those of the outside world.

Features

- Fabricated from steel, which has a high density comparable to that of lead
- The panels are 850 mm wide and 50mm thick and contain two Rockwool slabs, a thin felt layer all inside the steel shell
- The optional windows are essentially modified standard panels and, as such, can take the place of any of the panels in the walls
- The same can be said of the doors (you can even have multiple doors if you require them) which can open inwards or outwards hinging on either side and contain a window strip measuring 1.3m x 0.2m
- Standard Esmono booths yield sound attenuation figures of approximately 35dBA
- The price includes ventilation ducts and fan
- Avoids building costs, disruption, architects etc and can be dismantled and reerected elsewhere with ease

In the UK alone, Studiospares have installed over 200 booths for a wide range of clients including universities, post-production houses, recording studios, television productions and home users.

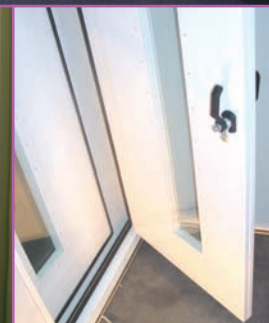
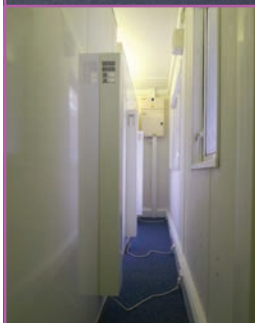

IMPORTANT
Please allow up to 4-6 weeks for delivery

A 2m x 2m Room weighs around half a ton so carriage charges will reflect the distance and weight. Please contact us for further details.

Optional Extras

For Standard Rooms And Vocal Booths

INTERNAL QUIET FAN UNIT

Secured to the internal ventilation panel. Draws air into the room via the room's own ventilation duct. Centrifugal fan all but eliminates fan turbulence and bearing noise. Variable speed. (Requires a mains point within the room)

WINDOW PANEL

A window panel with a double glazed window 800mm x 700mm is available. Safety glass (6mm thick) is used.

SECOND DOOR

A room can be fitted with two doors. This is often preferable with larger installations. The second door cannot be fitted retrospectively.

TOUCH UP AEROSOL PAINT

Useful to touch up abrasions and marks.

FOAM STRIP

24 metre (3 x 8m rolls) of expanding foam strip (required if the room is re-erected elsewhere).

Construction Service and Logistics

Assembly can be accomplished by two people with comprehensive DIY skills and basic tools. However the door and ceiling panels weigh around 50-60kg each and the door panel 180kg. Handling such weights can be problematic and can be dangerous. If you have any doubts about your ability to assemble the room contact our installation team who can provide expert tips or provide a quotation for professional installation.

Description	Kilos	Code	Price (Ex VAT)
Booths 2m High externally - 2m x 2m	597	411-500	£4135.00
Booths 2m High externally - 2.85m x 2m	692	411-510	£4970.00
Booths 2m High externally - 2.85m x 2.85m	790	411-690	£7295.00
Booths 2m High externally - 3.7m x 2m	860	411-520	£5745.00
Booths 2m High externally - 4m x 2.85m	1120	411-530	£7775.00
Booths 2m High externally - 4m x 3.7m	1290	411-540	£8795.00
Booths 2.2m High externally - 2m x 2m	625	411-550	£4820.00
Booths 2.2m High externally - 2.85m x 2m	761	411-560	£5575.00
Booths 2.2m High externally - 2.85m x 2.85m	850	411-710	£8025.00
Booths 2.2m High externally - 3.7m x 2m	895	411-570	£6270.00
Booths 2.2m High externally - 4m x 2.85m	1025	411-580	£8770.00
Booths 2.2m High externally - 4m x 3.7m	1330	411-590	£9725.00
Extras - Internal Fan Unit	-	411-970	£412.50
Extras - Window 2m	-	411-600	£269.00
Extras - Window 2.2m	-	411-610	£299.00
Extras - Foam Strip	-	411-620	£59.95
Extras - Paint	-	411-630	£16.60
Extras - Door 2m	-	411-640	£620.83
Extras - Door 2.2m	-	411-650	£820.83





Esmono Vocal Booth

Acoustic Isolation Room

The Esmono Vocal Booth has enjoyed unparalleled success and led to many requests for a smaller version for announcers, voice overs and vocalists.

The booth uses wall panels and a door assembly interchangeable with the full-size Isolation room. Only the ceiling panel is different. The Isolation room has always been noted for well balanced acoustics. It is unlikely that the Booth would require any further internal acoustic treatment. The door can be hung to open in or out and hinge on the left or right.

Features

- Internal height is 2 metres or 2.2 metres (less the thickness of any internal flooring)
- The Booth can be fitted with the optional window panel **Code 411-600/-610**
- Window size is 700mm x 800mm
- The door includes a double glazed window 1360 high x 200mm wide
- Ventilation system included
- The internal fan is quiet, not silent
- For Accessories, please see details on Esmono Room page

Construction Service and Logistics

Studiospares can usually arrange for the rooms to be erected on site. Please discuss your requirements with our technical staff, who will be happy to offer a quotation for this service.

Please allow up to 4-6 weeks for delivery.

Description	Code	Price (Excluding VAT)
Booth 2m High	411-660	£3370.00
Booth 2.2m High	411-670	£3780.00

Esmono Sound 80mm

Acoustic Isolation Room



80mm thick walls to accommodate additional absorbing material. Ducted ventilation system with internal fan included. Panels contain four sound absorbing components.

Double walled Room 2m x 2m x 2m Centre frequency of octave band
 62.5 125 250 500 1K 2K 4K dB(A)
 Reduction of noise level 23.5 23 27 41 46.5 48 49.5
 Measured with a pink noise sound source and a class 1 sound level meter on the inside and outside.
 Average reduction value is 40dB with a tolerance of ± 3dB through environmental variables.

Prices start from **£4890.00**

For all details on sizes, options and accessories, please contact our Esmono Room Installation expert **Roy Collins** for further information.

Double Walled Esmono Rooms



For extreme situations where the level of noise is excessive, Esmono have responded by literally constructing an isolation room within an isolation room. It essentially consists of the existing product contained within an identical outer room.

Prices start from **£8900.00**

For all details on sizes, options and accessories, please contact our Esmono Room Installation expert **Roy Collins** for further information.

IMPORTANT - Please allow up to 4-6 weeks for delivery
 A 2m x 2m Room weighs around a ton so carriage charges will reflect the distance and weight. Please contact us for further details.

Esmono Room Case Study

University Of Kent

During the summer of 2013, Studiospares received a call from Coombs Construction of Canterbury to supply and fully install seven Esmono Sound Booths for the University of Kent at the historic dockyard at Medway.

After many meetings at their offices and on site, a schedule of works was put in place to meet with the University's requirements with the work starting the 1st week of October 2013. Deliveries from the manufacturer had to be phased to overcome the logistical problems of storing the panels prior to erection.



The works were to include four small rooms for single usage and three larger double walled rooms for band and group practice. Studiospares were to plan out and erect the rooms whilst certified electrical contractors were to install and subsequently certify the electrical installation. The rooms were to have their own separate electrical supply to include wired sockets, lighting and RCD safety cut outs. Studiospares managed and fitted all the various multicore cables and interface boards for equipment signal inputs and outputs.

All units were fully installed in just under four weeks which was two days ahead of schedule.

Roy Collins
 Chief Installation Engineer

ACOUSTICS

Vocal Isolation Booths

Clearsonic Isopac-E

Stage Performer Isolation Booth

A large vocal booth able to accommodate up to 3 people.

- Ideal for recording guitars, brass, woodwinds, and other acoustic instruments
- Popular for noisy brass instruments
- Reduces sound by approximately 50-60%
- Stores flat. Easily relocated.
- Dimensions 1823mm W x 1823mm D x 1956mm H



Clearsonic Isopac-F

Vocal/Instrument Isolation Booth

A medium vocal booth that is also great for isolating and recording guitars, brass, woodwinds, and other acoustic instruments.

- Dimensions mm: 1524 wide x 1524 deep x 1956 tall
- Amount of Sound Reduction: 50-60%
- Uses the STC4 and ST54 lid sections
- The lid sections are 4' deep and work well on a booth of this size

Clearsonic Isopac-G

Drum Isolation Booth

A 4' diameter vocal booth that will hold a single vocalist.

- Works well in situations where space is tight
- Constructed in a similar style to the MegaPac
- Uses a combination of clear panels and SORBER to achieve maximum sound reduction
- Dimensions: 4' wide x 4' deep x 6.5' tall
- Amount of Sound Reduction: 60-70%

Clearsonic Isopac-H

Vocal Isolation Booth

Designed to be used in translation, interpretation and voice-over applications.

- Will fit one or two people seated comfortably at a table
- Amount of Sound Reduction: 50-60%
- Lid absorbs and reduces sound leakage
- 150mm 2-speed, low noise fan
- Dimensions mm: 1524W x 1524D x 1650H

Clearsonic Isopac-I

Vocal Isolation Booth

Will fit one or two people seated comfortably at a table.

- Dimensions mm: 1829W x 1524D x 1651H
- Application: Voice Over/Translation Booth
- Lid absorbs and reduces sound leakage
- 2-speed, low noise fan
- Amount of Sound Reduction: 50-60%

Clearsonic Isopac-J

Vocal/Instrument Isolation Booth

Vocal & Instrument Isolation Booth.

- 2-speed, low noise fan
- Lid absorbs and reduces sound leakage
- Amount of Sound Reduction: 60-70%
- Dimensions mm: 1524W x 1524D x 1930H

Description	Code	Price (Ex VAT)
Isopac-E Dark Grey	463-260	£1485.00
Isopac-F Light Grey	463-370	£955.00
Isopac-G Light Grey	746-290	£1175.00
Isopac-H Light Grey	463-380	£874.00
Isopac-I Light Grey	463-390	£1040.00
Isopac-J Light Grey	463-400	£1450.00

Studiospares RED Mini Booth

Desktop Portable Isolation Booth

Effectively isolates the recording from unwanted room reverberations...

An eloquent solution for desktop studio artists who experience problems with room reverberation. The doors provide additional screening against rear and side reflections. Other versions mounted on a microphone stand are dangerously top heavy. They have to be placed at the end of the desk, often too far away to get the clarity of a close miked recording. The Mini Booth includes a threaded spigot to support the microphone. A cable access hole through the bottom of the cabinet keeps cables tidy. Rubber feet and a carrying handle are thoughtful facilities, which complete the package.



Description	Code	Price (Ex VAT)
RED Mini Booth	465-440	£129.00



Height Extender + Lids



ILLUSTRATED - Extenders plus a Sorber lid.

Should the 1676mm height not be enough 457mm transparent Height Extenders are available, each 600mm wide.

- Held together vertically by transparent H section
- Held together horizontally by transparent hinge which clicks into place
- Horizontal rear telescopic bar supports lid

Sorber Lid

- Lid height can be increased by 300mm. All lids 610mm wide
- Mid lid 1676mm End lids trapezoidal, between 1270-1676mm

Description	Code	Price (Ex VAT)
Height Extender each	463-050	£37.50
Lid Width Extender Dark Grey	463-107	£67.20
Sorber Lid Light Grey	463-100	£215.00
Sorber Lid Dark Grey	463-105	£215.00
Zippered Carrying Case	463-110	£130.00

Clearsonic Isopac-A

Stage Performer Isolation Booth

An effective method of acoustically isolating loud stage performers whilst retaining their presence on stage.

- Dimensions. 214mm W x 1080mm D x 1960mm H
- Sufficient space to house a drum kit
- Reduces sound by approximately 50-60%
- Stores flat. Easily relocated.



Clearsonic Isopac-B

Stage Performer Isolation Booth

Has a similar sound attenuation to Isopac A but is slightly smaller. Allows the bass drum to be on view.

- Reduces sound by approximately 50-60%
- Sufficient space to house a drum kit
- Performer does not feel isolated from the rest
- Stores flat. Easily relocated.
- Dimensions 1829mm W x 2134mm D x 1959 H

Clearsonic Isopac-C

Drum Isolation Booth

Drumkit easily converted into an IsoPac A or B.

- Application, Drumkits
- Dimensions mm: 1830W x 2134D x 1676H

Clearsonic Isopac-D

Drum Isolation Booth

Drummer housed on a floor isolation platform within the booth.

- Drumkit application
- Dimensions mm: 1830W x 1830D x 1220H



Description	Code	Price (Ex VAT)
Isopac-A Dark Grey	463-250	£1725.00
Isopac-A Light Grey	463-255	£1725.00
Isopac-B	463-240	£1465.00
Isopac-C Dark Grey	463-290	£1040.00
Isopac-D Light Grey	463-360	£665.00

ACOUSTICS
Drum Isolation Booths

Clearsonic Minimega

Drum Isolation Booth

A slightly smaller version of the MegaPac.

- Dimensions mm: 2133W x 1828D x 1956H
- Lid absorbs and reduces sound leakage
- Amount of Sound Reduction: 70%
- 2-speed, low noise fan



Description	Code	Price (Ex VAT)
Minimega Light Grey	463-420	£2225.00

VISIT our trade counter

You'll get friendly advice and immediate access to 8000+ product lines!

1000s of products Available from stock!

DELIVERY BEFORE NOON no problem

Clearsonic MegaPac

Isolation Booth

Useful in applications where maximum isolation is needed..

Designed for a full drum kit and drama recording, the MegaPac features 360° of ClearSonic Panels for maximum sound isolation. ClearSonic shields in the back means less opening for sound to escape. A full seven feet of interior headroom is achieved by using the AX18 Height Extenders. There is an A5-7 in front, and an A5-5 in the rear. The two panel systems do not actually connect to each other, so the end panel of the A5-5 can be moved and used as a door.

The MegaPac includes two lid support bars for maximum stability. Nineteen S2 and twelve S1 SORBER baffles provide a whopping 112 square feet of interior sound absorption for maximum acoustic performance inside and out.



Description	Code	Price (Ex VAT)
MegaPac Light Grey	463-410	£2499.00



Clearsonic Portable Isolation Booths

Modular Portable Sound Booth



Drum kit surrounded by 1676mm panels with extender panel above and topped with a Sorber lid.

The rear consists of 1676mm light Grey sorber panels plus 600mm high panels at the front.



Drum kit surrounded by 1120mm panels.

The rear consists of 1120mm light Grey Sorber panels plus 600mm high Sorber side panels.

A coordinated range of products that help control sound by isolation and absorption.

- Available in 3 heights and various configurations
- Each section consists of a transparent acrylic panel 600mm (24") wide
- Panel heights are 900mm, 1120mm (44") and 1676mm (66")
- Easily transportable
- Great for reducing mic spill in live situations
- Ideal for places of worship

Description	Code	Price (Ex VAT)
900mm		
3 Section A3-3	463-220	£175.00
1120mm		
3 Section A4-3	463-140	£207.50
4 Section A4-4	463-150	£275.00
5 Section A4-5	463-160	£349.00
1 Section add-on hinge A4-1	463-170	£72.00
Spare Hinge	463-210	£21.80
1676mm		
3 Section A5-3	463-000	£275.00
4 Section A5-4	463-010	£345.00
5 Section A5-5	463-020	£416.00
6 Section A5-6	463-030	£499.99
1 Section add-on hinge A5-1	463-040	£100.67

(Detailed Sorber information is in the Portable Acoustic Treatment section) Note picture shows a booth with height extender and Sorber lid.

Clearsonic Sorber SX12

Height Extender



SORBER height extenders consist of two 1-foot high by 2-foot wide panels hinged together (overall width of 4-feet). They are designed to extend our S5-2 baffles to the same overall height as the A5 panel with an AX12 height extender.

Description	Code	Price (Ex VAT)
Sorber SX12 Dark Grey	463-340	£65.20
Sorber SX12 Light Grey	463-350	£65.20

Auralex Mopads

Speaker Isolation

Designed to provide sonic isolation between monitors and what ever they are resting on.

- Can instantly improve the accuracy of your monitoring system
- Wedge Adjusters allowing you to tilt each speaker to listening angles of +4°, +8°, -4°, -8° and 0°
- Colour Charcoal Grey
- Each set as sold contains 4 pads, ideal for placing 2 under each speaker



Description	Code	Price (Ex VAT)
MoPADs x4	461-600	£22.50

ACOUSTICS

Speaker Sound Isolation

Auralex Propad

Monitor Isolator

The Auralex® ProPADs™ feature a durable, three layer highly damped construction that provides superior isolation from the vibrations and resonant energy created by the studio monitors.

- Increased Midrange Resolution
- Deeper, more Focused Soundstage
- Improved Low-Frequency Definition
- Angle Adjustable to Optimize Listening Axis
- 8" wide x 13" deep x 2.125" thick



Auralex Propad XL

Monitor Isolator

As above but formatted to be compatible with many larger twin woofer, horizontally oriented nearfield monitors. 19" wide x 13" long; 2.125" thickness.

Description	Code	Price (Ex VAT)
Propad	462-500	£71.90
Propad XL	462-690	£149.17

Auralex Mopads-XL

Speaker Isolation

These extra-large versions of the original Auralex MoPad decouple your speakers from whichever surface you place them on.

- Size mm 222 wide x 285 deep x 50 thick
- 2 pads per set



Description	Code	Price (Ex VAT)
Mopads-XL x2	462-330	£40.72

Universal Acoustics Vibro-Pads

Monitor Support

Universal Acoustics Vibro-Pads are specially formulated anti-compression pads.

- Designed to improve the accuracy of your nearfield monitors
- Isolates and de-couples the monitor from the surface they are resting on
- Each set of the Vibro-Pads includes 4 x 100mm wide x 300mm deep pad sets



Description	Code	Price (Ex VAT)
Vibro-Pads 4 x 100m	466-460	£30.00

ALL PRICES EXCLUSIVE OF VAT.

ACOUSTICS

Speaker Sound Isolation

CONTINUED

Studiospares Monitor Pads Pack of 4

Monitor Support

Keep the sound coming from the speakers, not the surface they are standing on...

Everything that can vibrate colours sound. That includes the surface the monitors are mounted on. These monitor pads decouple the energy from the supporting surface. OK for speakers up to 20kg. Dims of supporting area, 280mm long x 100 mm wide by 25 thick. Pack of 4 pieces allows 2 to be mounted under each monitor.

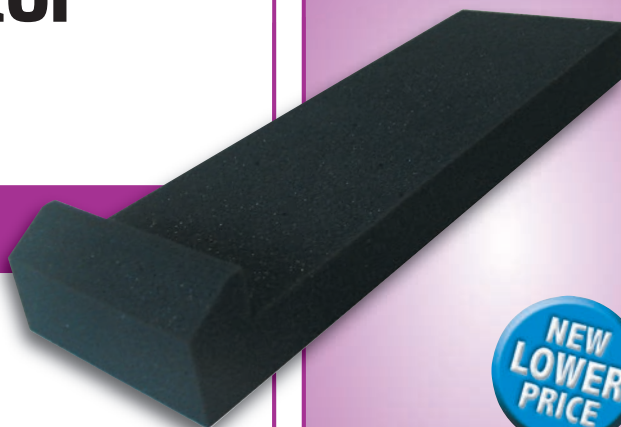

NEW LOWER PRICE

Description	Code	Price (Ex VAT)
Monitor Pads - Pack of 4	465-110	£12.46



Studiospares Monitor Isolation Pads

Speaker Isolation

Effective decoupling of the cabinet vibrations from the supporting structure.

- Eliminates sounds reaching supporting structure adding clarity to the sound
- Great for desktop and close monitors
- 2 parts. Allows speaker to be angled forward or remain flat.
- Dimensions 5" mm 170W x 300D x 40H
- Dimensions 8" mm 390W x 280D x 40H



NEW LOWER PRICE

Description	Code	Price (Ex VAT)
5" Pair	465-410	£8.33
8" Pair	465-420	£12.49

Auralex Gramma

Amp/Monitor Support

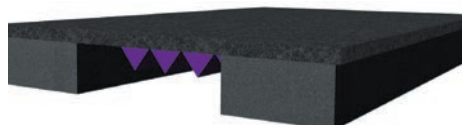

The GRAMMA from Auralex is an incredibly effective device that's used to float an amp or loudspeaker and yields nearly total acoustic isolation.

- Complete with a carrying handle
- Complete with carpet, Studiofoam wedges (underneath) and Platform
- Dimensions 580mm long x 380mm wide x 70mm high
- 1 or 2 GRAMMAS will support nearly all amps, speaker cabinets, subwoofers, and monitors.

2+ PRICE £36.20

Description	Code	Price (Ex VAT)
Gramma	461-180	£38.20

Floor Sound Isolation

Clearsonic IsoFloor Panels

600mm Square

The IsoFloor panels are a three part sandwich housed in a tough man made fibrous fabric which is Velcro receptive (loop part).

- Stops noise through the floor
- Consists of a 6 mm thick MDF base, a 38mm thick Rockwool style slab and another sheet of 12mm chipboard forms the top layer
- Easy to join together
- 600mm x 600mm
- Total thickness only 50mm (2")



Exposed internal sandwich construction

Description	Code	Price (Ex VAT)
IsoFloor Panel	463-130	£46.30

Studiospares Speaker Isolation Riser

Speaker Isolation

Stopping the bass thump of speakers and cabinets resonating through a building has never been easier.

- A sandwich of carpet, plywood and foam
- Carrying handle built in
- Design is inherently stable
- Maximum loading 135kg placed centrally
- Dimensions mm 570W x 370D x 68H



Description	Code	Price (Ex VAT)
Speaker Isolation Riser	465-310	£24.95

Auralex Great Gramma

Speaker Support

Great GRAMMA is an ideal option for performing musicians and studio engineers.

- Built on the success of GRAMMA
- Stops that uncontrollable rumble where your amp vibrates with the floor
- Gives you a better tone and quality
- 30" long x 19" wide x 2.75" high
- Weighs 300lbs

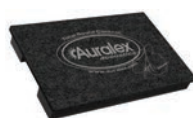

Description	Code	Price (Ex VAT)
Great GRAMMA	461-940	£68.30

Auralex Hovermat

Portable Drumkit Mat

Sturdy, slip-resistant drummers' mat that improves acoustical isolation and clarifies your drums' tone.

- Non-slip surface holds drums and hardware in place
- Fabricated from Auralex SheetBlok
- Can be rolled up after the performance
- Dimensions mm: 1825 x 1519 x 6



Description	Code	Price (Ex VAT)
Hovermat	462-510	£165.00

VISIT
our trade counter
You'll get friendly advice and immediate access to 8000+ product lines!
free parking for 40 cars

THE
website
Keep up to date with all the latest products and current prices on the Studiospares website!
check out www.studiospares.com

FOR
fax orders
Use our fax number...
020 8450 4390

Auralex U-Boats

Floating Floor Joist Isolator

Used to support framing members and isolate them from the surrounding structure.



- A specially-formulated rubber U-shaped channel
- The industry's most affordable floating solution
- Width 54mm (2.1/8") Width of slot 38mm (1.5") Height within slot 30mm (1.3/16"), Overall height 38mm (1.5")
- Sold individually

Description	Code	Price (Ex VAT)
U-Boats	461-150	£3.41

Auralex Subdude 2/HT

Sub Platform

An isolation platform featuring a stylish velour covering over an inert structural layer that floats on a cushion of acclaimed Auralex Platform™



- Dimensions mm, Subdude 2: 380 x 380 x 44, Subdude HT: 457 x 559 x 44
- Originally intended to sit under subwoofers in a domestic environment
- Now used in pro sound environments
- Drastically reduces bass thump getting into the supporting structure and the floor
- Constructed from a 19mm MDF base

Description	Code	Price (Ex VAT)
Subdude 2	461-920	£49.90
Subdude HT	462-470	£51.70

Auralex Mineral Fibre

Insulation

The best way to tighten up a room's sound and make it more soundproof in the process.



- Specifically designed for acoustical usage
- Better sound isolation, acoustic absorption and lower moisture absorption
- Quantity, Per Box: 2" - 6 (48 sq. ft.), 4" - 3 (24 sq. ft.)
- Flame Retardancy: Class A



Description	Code	Price (Ex VAT)
Mineral Fibre 2" x6	462-620	£90.83
Mineral Fibre 4" x3	462-620	£90.83

Auralex Platsheet

Platform Isolation Sheet

25mm sheets of high density foam that offer isolation and decoupling benefits.

- An effective way to decouple speakers when installing them in wall enclosures or cabinets
- Can withstand the weight of speaker cabinets
- Can be cut to irregular shapes and attached to any flat surface to reduce high frequencies
- Sheet size mm, 1200 x 600 x 25
- Sold individually

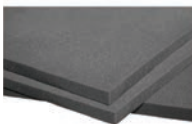

Description	Code	Price (Ex VAT)
Platsheet	462-480	£18.40

Studiospares Acoustistop

Thick Rubber Floor Tiles

Primarily intended to drastically reduce floor borne noise from any source including performers, orchestras or even from footsteps.

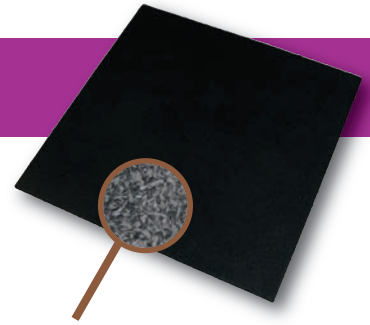

Surface highly magnified

Acoustistop tiles are both stand alone products which can be used as a carpet tile or used as a very high performance underlay. The non slip surface is "springy" and slightly compresses under weight so anything dropped on the tile will probably survive intact. Great for laying under drum kits. Its open cell surface also adds sound absorption qualities. It is a very dense product, (125 tiles weigh in at one ton). Can be shaped with a sharp knife. Supplied individually.

Tiles measure 1m x 1m and are 10mm thick. Weight 8kg each. Manufactured from 100% recycled materials.

Description	Code	Price (Ex VAT)
Acoustistop	465-130	£21.27



Auralex Sheetblok-Xtra

Sound Isolation Roll

About 6dB more effective than solid lead at stopping the transmission of sound.



- Using sheetblok between drywall layers, floating ceilings and walls provides extra acoustic absorption
- Keeps sound transmission to a minimum
- Dense, limp-mass vinyl material
- 5m x 1m Roll
- Most effective when used as one component of a multi-layered construction scheme



Auralex Sheetblok-Plus

Adhesive-Backed Sound Isolation Roll

A dense, limp-mass material that comes with a PSA (pressure-sensitive adhesive) already attached!



- Just peel off the PSA backing and apply the SheetBlok Plus to the area to be covered
- Available in 4'x30' rolls only; Colour Black

Description	Code	Price (Ex VAT)
Sheetblok-Xtra	462-600	£107.50
Sheetblok-Plus	462-610	£390.83

Auralex Platform Sold Singly

Platform from Auralex is a specialised form of their Studiofoam

- Designed to cope better with the studio environment and even with the rigours of on-the-road life
- Ideal for use in supporting a floating floor, eg for a drum riser
- Greatly purifies the tone of whatever is on the riser
- Dims 5cm x 10cm x 120cm (2" x 4" x 4')
- Decking material (chipboard etc) not included

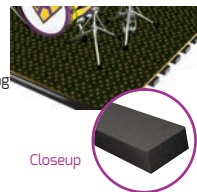

Closeup

Description	Code	Price (Ex VAT)
Platform x1	461-330	£10.54

Acoustic Antistatic Floor Tiles

These loop pile tufted carpet tiles.

- Excellent sound absorption
- Heavy duty 'contract-standard' long life
- Choice of good-looking colours
- Superb value for money
- Meet the highest quality standards
- Pass all relevant fire safety regulations
- Dims, 50cm x 50cm, Thickness 7.5mm

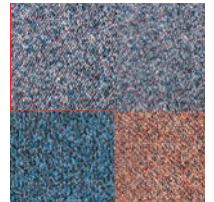

Colour	Description	Code
Gunmetal Grey	Dark Grey with a hint of Blue	411-060
Midnight Blue	Dark Blue tinged with Grey	411-050
Sienna	Autumnal Beige	411-070

Double Sided Sticky Tape

Where tiles do not butt up against an edge and can easily move, use a double sided sticky tape. 25mm wide, 50 metres long.

Description	Code	Price (Ex VAT)
Gunmetal Grey x1	411-060	£6.42
Midnight Blue x1	411-050	£6.42
Sienna x1	411-070	£6.42
Double Sided Sticky Tape	126-650	£4.80

No Noise Floor Panel MKII

2400 x 600 x 35

No Noise floor panels are a very high performance multilayer floor boarding that attenuate floor borne sound entering the structure of the building.

- Two layers of moisture resistant chipboard separated by visco elastic strips with an acoustic felt underside to contour minor floor irregularities.
- Used successfully by our Esmono Room installation team to combat noise entering or leaving the room.



Description	Code	Price (Ex VAT)
No Noise Floor Panel MkII	465-450	£44.80

1000s
of products
Available from stock!

VISIT
our trade counter
You'll get friendly advice and immediate access to 8000+ product lines!

ACOUSTICS

Speaker Sound Isolation

CONTINUED

Auralex Hoverdeck

Isolation Riser

Specifically engineered to reduce coloration from floor resonance.

- Decouples the drum kit from the structure, resulting in a tighter, more pure sound for both studio and FOH
- Rugged MDF laminate core
- Web-like ISO-Puck modular risers
- Utilises a set of low-profile isolating boards that assemble quickly
- The HD-64Gig is designed for typical four and five-piece drum kits
- The HD-88Concert is configured for larger drum kits and touring applications
- Either model is offered with an optional rugged road case.

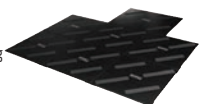

Description	Code	Price (Ex VAT)
HD-64Gig	462-710	£315.83
HD-64Gig with Roadcase	462-715	£450.00
HD-88Concert	462-720	£762.50
HD-88Concert with Roadcase	462-725	£1017.00
HD-22 Add-on Platforms	462-730	£90.00
Road Case	462-740	£124.00

Sound Deadening Felt Underlay

Essentially a carpet underlay material, with excellent sound absorption qualities.

- Easy to cut and lay
- As used in many studio and staging applications
- Standard width of 1.37m (54 inches)
- Sold by the metre
- Please note that the price for 1 metre gives you 1.37 square metres of felt



Description	Code	Price (Ex VAT)
Felt Underlay	411-040	£8.62

Auralex Platfeet 3-Pack

Mic Stand Isolation Blocks

Auralex Platfeet are the most effective tool to float your mic stand.

- Slide these foam blocks under each foot
- OK for floating snare drums and floor toms
- Can prevent structure-borne vibrations



Description	Code	Price (Ex VAT)
Platfeet 3-Pack	462-320	£11.50

PRICE changes

This catalogue was priced on 1st December 2014.

Current prices may be higher...

see our website for up to date prices.

ACOUSTICS

General Sound Isolation

Studiospares Acoustistop

Sound Barrier Sheetting

Acoustistop is non invasive and highly effective.

The high energy levels developed by modern bass drivers and more importantly, by playing musicians makes keeping sound in, a difficult issue. On the other side of the wall they are trying to keep the sound out. Both problems can be reduced by adding mass to the adjoining wall. Bricks, Breezeblock and Thermalite are effective but raise many practical problems. The simplest way is to add mass to the existing wall. In industry, lead sheet has been used sandwiched between walls. Logically then why not attach the sheeting to the face of the wall? Acoustistop is a lead substitute which bypasses all the problems associated with lead. The lead substitute is a mineral loaded polymeric barrier with a mass of 5.0 kg/m2



Acoustistop consists of a Mineral Loaded Polymeric Barrier with a mass of 5.00kg/m2 and a thickness of 2mm.

Description	Code	Price (Ex VAT)
3m x 1.2m	465-070	£49.99
1m x 1.2m	465-075	£21.50



Rockwool RW3

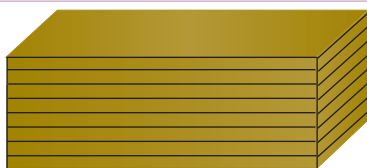

Most Rockwool is used for thermal insulation. However, Rockwool RW3 is used as an aid to overcoming problems of sound transmission through walls. It is manufactured from a volcanic rock to which coke and limestone is added. The molten material is spun into wool with added binders then resin impregnated. It is clean to work with and easily cut with a knife. Rockwool produce many grades, thicknesses and finishes. Studiospares in consultation with acoustic designers and the manufacturers selected the grade and thickness best suited and most cost effective for noise attenuation through walls.

NEW PACK SIZE. One pack of Rockwool now contains 8 slabs, each of size 1200 x 600 x 50mm, which cover a total area of 5.76 square metres. Weight 20 kilos. Pack size 1200 x 600 x 480mm = 0.36 cubic metres.

Description	Code	Price (Ex VAT)
RW3 x8	401-982	£35.64



Studiospares Sound Stopper

Acoustic Panels

Uses a polymer barrier material which has the same density and identical acoustic resilience as lead.

- Sandwich construction, used extensively in industry to isolate unwanted sounds
- A weighted noise reduction of 27dB
- 2m x 1.2m x 14mm. Wt 16kg
- Supplied in a cardboard roll



Description	Code	Price (Ex VAT)
Sound Stopper	465-000	£85.00

Neoprene Sound Insulation Strip

Neoprene strip is easily the most popular structural sound insulation material.

- Chemically stable
- Can be easily worked, glued, cut and will not harden at low temperatures
- We have selected the most appropriate densities and formulations to suit the two most common applications of this



Multipurpose Strip

Multipurpose applications. Generally used as a separator between parallel surfaces being held together such as studding being attached all over an existing wall or as a seating for glass in a frame. Sold by the metre.

Description	Code	Price (Ex VAT)
Non Sticky backed 13mm x 3mm	406-080	£1.19
Sticky backed 12mm x 3mm	406-680	£1.33

Extra Thick Strip

Extra thick grade specially produced to support the weight of partition walls. The strip should be placed between the partition wall, the floor, walls and ceilings. This will greatly reduce the twin problems of sound transmission between the building's structure and the partition wall.

Description	Code	Price (Ex VAT)
Non Sticky backed 50mm x 13mm	406-070	£4.67
Sticky backed 49mm x 12mm	406-670	£5.83

Studiospares Soundproofing Foam

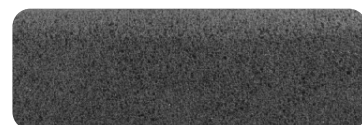

Inch-thick (25mm) fire-proof foam as recommended in Sound on Sound's guide to soundproofing your studio.

- Large sheet 2m x 1.5m
- Supplied rolled up and can easily be cut to size with a sharp knife

Description	Code	Price (Ex VAT)
2000 x 1500 x 25mm	465-620	£41.20

MORE PRODUCTS online

Vicoustic Rubber Strip 10m

Rubber Strip is a complementary acoustic product mainly designed for isolating joints around windows and doors.

- Dimensions 10mm x 5mm
- Manufactured from EPDM
- Fire rating ISO 375. FMV5302
- Colour dark grey

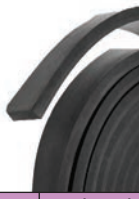

Description	Code	Price (Ex VAT)
Rubber Strip 10m	468-460	£15.83

ACOUSTICS

Portable Sound Screens

Auralex ProGo-26

Moveable Freestanding Acoustical Panels



Moveable, highly efficient absorbers that are effective tools in the studio, on stage and more.

- Fabric-wrapped moveable absorption treatment
- Reduces excessive reverberation
- Reconfigurable to tune your space
- Minimize sound leakage
- Expand your ProGo array as your needs change
- 2' wide x 6' tall x 4" deep
- Rubber isolation feet included
- Shown in Obsidian



Description	Code	Price (Ex VAT)
ProGo-26 Obsidian	462-790	£349.17
ProGo-26 Sandstone	462-791	£349.17

Soundcheck Acoustic Screens

These screens have been designed to provide total flexibility.

- Screens are linked together by a 4 way meeting post to form single lines, L shapes, U shapes, T shapes, and 4 way intersections
- Meeting posts 1200mm high
- Secured together by recessed metal tabs
- Panels can be turned 90 degrees
- Screens are available in 2 sizes
- Screens are available in 7 colours



Description	Code	Price (Ex VAT)
Meeting Post	442-000	£41.50
Size 1 1200mmH x 1500mmW	442-11X	£349.00
Size 2 1200mmH x 1800mmW	442-12X	£399.00

X = Colour Number

Colours



The appropriate code number is ascertained as follows. All screens include the first four digits 442-1xx followed by a fifth and sixth digit. The fifth digit is the size in mm. 1200 x 1500 = 1 and 1200 x 1800 = 2.

The last digit is the colour. Black = 3 Grey = 4, Claret = 5, Purple = 6, Royal Blue = 7, Marmalade = 8, Juniper = 9.

For example a 1200 mm x 1500 mm screen coloured Purple would have a Code 442-116. The price is only affected by the size, not the colour.

Freestanding panels require two meeting posts for support. Two panels require 3 meeting posts etc. Popular colours are stocked. Others are on a two week delivery.

Studiospares Acoustic Screens
Portable Sound Screens

Manufactured by Soundcheck, a company who specialise in controlling the acoustics of public buildings, including famous churches and prestigious cinema complexes.

Studiospares have investigated the Acoustic Screen market and found many shortcomings. Some are unnecessarily heavy because they do not reflect current acoustic technology. Others are flimsy and are more appropriately visual screens, ie. they cut the line of sight but not the sound. The technology for the screens came from the development of wall mounted acoustic panels used in cinema multiplexes to enable such cinemas to achieve THX certification, an independent performance criterion for the sound, vision and acoustics of cinemas. A noise reduction coefficient of up to 0.92 at 1000Hz would be typical for these screens. They comprise an extruded frame which houses the internal Class 0 acoustic foam material. For extra strength and enhanced acoustic properties, the front surface is a hard glass fibre material. The composite structure means that one side is more absorbing, the other more reflective, allowing great flexibility of usage, whether in the studio, practice room, or concert hall.

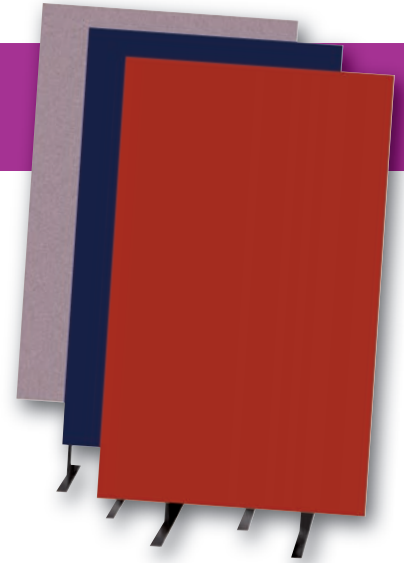

3 colours, Lead Grey, Claret Red, and Royal Blue. Size is 900mm Width x 1500mm Height x 42mm thick.

Description	Code	Price (Ex VAT)
Grey	411-200	£332.50
Red	411-210	£332.50
Blue	411-220	£332.50



ACOUSTICS

Acoustic Panels

Clearsonic Sorber Panels

Acoustic Screens

Sorber Panels are either 1220mm or 1676mm high.

- Thickness is 37mm
- Supplied as a linked pair with a total width of 1200mm (2x 600mm)
- Panels support themselves so have to be set in a wide V shape to remain upright
- Pairs maybe linked by pre-cut press together strips along the top and bottom sides
- For transportation both halves fold together like closing a book.
- Carrying is simple as a handle is sewn into the fold



Description	Code	Price (Ex VAT)
Light Grey 1220mm, 8.4kg	463-070	£99.70
Light Grey 1676mm, 11.8kg	463-080	£158.00
Dark Grey 1220mm, 8.4kg	463-180	£93.60
Dark Grey 1676mm, 11.8kg	463-190	£158.00

Short Sorber Panels

These are sold singly. They usually stand vertically on the floor and against the inside transparent wall of the Clearsonic Isolation Booth. Supplied with a small strip of self adhesive Velcro that is attached to the glass one side and to the face of the Sorber panel the other side. S1 is 16.25"H x 22"W, S2 is 24"H x 22"W and S3 is 33"H x 22"W.

Description	Code	Price (Ex VAT)
S1 Light Grey	463-310	£24.99
S1 Dark Grey	463-300	£24.99
S2 Light Grey	463-090	£35.41
S2 Dark Grey	463-200	£35.41
S3 Light Grey	463-330	£53.67
S3 Dark Grey	463-320	£53.67

Soundcheck Modular Acoustic Panels

Like our acoustic screens, the panels have a dense fibreglass core.

- Faced on one side and all edges with screen fabric
- Simply adhered to walls either as individual panels or butt jointed together
- Stunning look with the wide range of fabrics
- Screens are available in 4 sizes



Description	Code	Price (Ex VAT)
Size 1 600mmH x 1200mmW	442-21X	£115.00
Size 2 1200mmH x 1200mmW	442-22X	£157.50
Size 3 1200mmH x 1500mmW	442-23X	£187.50
Size 4 1200mmH x 1800mmW	442-24X	£207.50

X = Colour Number

Colours



The appropriate code number is ascertained as follows. All screens include the first four digits 442-2xx followed by a fifth and sixth digit. The fifth digit is the Size in mm.

600 x 1200 = 1, 1200 x 1200 = 2, 1200 x 1500 = 3, 1200 x 1800 = 4.

The last digit is the colour. Black = 3 Grey = 4, Claret = 5, Purple = 6, Royal Blue = 7, Marmalade = 8, Juniper = 9.

For example a 1200mm x 1200mm screen coloured Claret would have a code 442-225. The price is only affected by the size, not the colour. Popular colours are stocked. Others are on a 4-6 weeks delivery.

DELIVERY BEFORE NOON
no problem

SATURDAY DELIVERY
no problem

DELIVERY BEFORE 10AM
no problem

ACOUSTICS

Acoustic Panels

CONTINUED

Studiospares Acoustic Panels

Bevelled Edge Acoustic Panels

A range of high performance fabric covered acoustic panels.

Designed for use in applications where superior acoustic performance is required and price is a consideration. Includes a hardened edge and corners. Cost reduced by large scale production. Dimensions (600mm or 300mm) x 1200mm x 25mm. Sandwich construction of high density fibreglass and an acoustic core covered in a choice of fabrics. Supplied with wall hangers. Optional wall clip available.



Description	Code	Price (Ex VAT)
600mm x 1200mm Grey	465-220	£24.92
600mm x 1200mm Beige	465-230	£24.92
600mm x 1200mm Black	465-240	£24.92
300mm x 1200mm Grey	465-380	£14.60
300mm x 1200mm Beige	465-390	£14.60
300mm x 1200mm Black	465-400	£14.60
Wall Clip for Acoustic Panels	465-430	£1.25



Vicoustic Flexi Panel

Acoustic Panels

Truly effective when applied in any type of space by a scientific combination of material, absorption surface and cavity thickness.

- Sizes A50, 600 x 600 x 50mm
- Sizes A75, 600 x 600 x 75mm
- Thicker panel better at low frequencies
- Can hide cables in the cavity

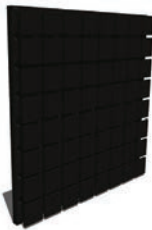

Description	Code	Price (Ex VAT)
A50 x1	468-310	£17.91
A75 x1	468-320	£26.87

Soundcheck Acoustic Panels



2+
PRICE
£67.30

Very similar to the acoustic screens but with a soft surface, Soundcheck acoustic panels are intended for wall-mounting and so do not have the holes for the stand supports, or the supports themselves. Lightweight and easy to handle, these panels are simple to attach to the wall using Velcro or double sided tape. The covering fabric on these panels (and on the screens) complies with B55867 part 2. A noise reduction coefficient of up to 0.92 at 1000Hz would be typical for these panels. 3 colours, Lead Grey, Claret Red and Royal Blue. Size is 450mm x 1000mm x 42mm thick.

Description	Code	Price (Ex VAT)
Grey	411-230	£89.50
Red	411-240	£89.50
Blue	411-250	£89.50
Black	411-300	£89.50

Vicoustic Wave Wood

Acoustic Panels

Designed to control excessive and unwanted frequencies, while maintaining an ambient, bright sound.

Vicoustic's flagship Wavewood panel has been specifically developed to treat acoustic problems without destroying a room's ambience, or over-deadening the sound. It can be used in control rooms, broadcast studios, live rooms where a range of instruments and voices are recorded, rehearsal rooms and other performance spaces. Wave Wood is made from a combination of acoustic foam and wood. Its instantly recognizable design results from unique research based on the acoustic properties of the wood and foam combined with non-linear sequential cavities that enable Wave Wood to act as both an absorber and diffuser. It is particularly effective in treating medium and high frequencies as well as solving issues such as flutter echoes. Wave Wood can also be highly effective in controlling low frequencies when fitted in the corners of a room and used as a bass trap.

Dimensions: 595mm (h) x 595mm (w) x 60 mm (d)
Finish/Colour: Cherry

Description	Code	Price (Ex VAT)
Wave Wood x1	468-450	£52.50
Wave Wood Light Brown x1	468-455	£52.50



1000s
of products
Available from stock!

VISIT
our trade counter

You'll get friendly advice and immediate access to 8000+ product lines!

Broadband Body Tiles

Acoustic Panels

Square or Bevel Edge Tiles.

- Thin Square Tiles - 600 x 600 x 40 mm
- Medium Square Tiles - 600 x 600 x 50 mm
- Large Square Tiles - 600 x 600 x 60 mm
- Thin Rectangle Tiles - 1200 x 600 x 40 mm
- Medium Rectangle Tiles - 1200 x 600 x 50 mm
- Large Rectangle Tiles - 1200 x 600 x 60 mm
- Available in Light Grey, Dark Grey or White



NEW

Description	Code	Price (Ex VAT)
Medium Square Dark Grey	771-061	£12.23
Large Square Dark Grey	771-062	£13.37
Thin Rectangle Dark Grey	771-063	£16.77
Medium Rectangle Dark Grey	771-064	£21.33
Large Rectangle Dark Grey	771-065	£23.60
Thin Square Bevel Dark Grey	771-070	£9.95
Med Square Bevel Dark Grey	771-071	£12.23
Large Square Bevel Dark Grey	771-072	£13.37
Thin Rect Bevel Dark Grey	771-073	£16.77
Medium Rect Bevel Dark Grey	771-074	£21.33
Large Rect Bevel Dark Grey	771-075	£23.60
Thin Square White	771-080	£12.68
Medium Square White	771-081	£15.80
Large Square White	771-082	£17.36
Thin Rectangle White	771-083	£22.02
Medium Rectangle White	771-084	£28.25
Large Rectangle White	771-085	£31.37
Thin Square Bevel White	771-090	£12.68
Med Square Bevel White	771-091	£15.80
Large Square Bevel White	771-092	£17.36
Thin Rectangle Bevel White	771-093	£22.02
Medium Rectangle Bevel White	771-094	£28.25
Large Rectangle Bevel White	771-095	£31.37

Broadband Flat Absorber

Wall Panel

Excellent broadband sound absorption.

- Reduces reverberation times to
- Improve the listening environment
- Available in Light Grey
- Dimensions: 1230 x 615 x 55 mm
- Metal channel to suit above, spacing 1210 mm



NEW

Description	Code	Price (Ex VAT)
Flat Absorber Light Grey	771-020	£15.69
Flat Metal Channel	771-030	£23.54

WANT a job?

Are you looking for a stable and rewarding career?

Studiospares are constantly expanding. We require additional staff for a variety of positions, working in a very congenial atmosphere. Practical experience of recording and/or live sound engineering would be preferable.

send in your CV in the first instance

FOR fax orders

Use our fax number...

020 8450 4390

Vicoustic Cinema Round Pro Premium

Wall Panels

Provides flexible and elegant solutions for sound control across a multitude of applications.

- Combines modern design with maximum acoustic efficiency
- High performance acoustic foam with a coloured fabric cover
- Highly efficient in the treatment of medium frequencies and the improvement of low ones
- Efficient absorption
- Easy to install
- Excellent value for money
- Dimensions: 1200 x 600 x 76 mm
- NOTE: the dimensions of this panel have a tolerance margin of +/-3 mm



NEW

Description	Code	Price (Ex VAT)
Cinema Round Blue x1	468-240	£113.33
Cinema Round Grey x1	468-230	£113.33
Cinema Round Beige x1	468-220	£113.33
Cinema Round Black x1	468-210	£113.33
Cinema Round Red x1	468-200	£113.33

ACOUSTICS

Acoustic Tiles

Auralex Studiofoam DST-112/ DST-114

Auralex DST tiles are made from the same high-spec foam as the Auralex Wedges. DST stands for Designer Series Treatment, and offers a stylish alternative cut to give you great possibilities for improving the look of your studio or home theatre.

DST-112

- 1ft x 1ft (303 x 303mm)
- Available in Charcoal Grey only
- Sold singly

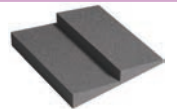

DST-114

- 1ft x 1ft (303 x 303mm), but has a different shape to the DST-112
- Available in 3 colours: Purple, Charcoal Grey and Burgundy
- Sold singly



Description	Code	Price (Ex VAT)
DST-112	461-400	£4.14
DST-114 Charcoal Grey	461-410	£3.95
DST-114 Purple	461-420	£3.95
DST-114 Burgundy	461-430	£3.95

Quantity discounts apply

Auralex Sonolite

Acoustic Panel

Provide excellent broad band frequency control.

- Fabric-wrapped Studiofoam® acoustical absorption panels
- Can be used for wall or ceiling applications
- Each SonoLite™ panel consists of Auralex's high performance Studiofoam®Pro acoustical foam
- SonoLite Dimensions: 24" x 24" x 1"
- Available Colours: Tan and Black



NEW

Description	Code	Price (Ex VAT)
Sonolite Black x1	462-750	£24.90
Sonolite Tan x1	462-751	£24.90

MORE PRODUCTS online

ALL PRICES EXCLUSIVE OF VAT.

ACOUSTICS

Acoustic Tiles

CONTINUED

WHAT are acoustiles?

STUDIOSPARES ACOUSTIC CONTROL SERIES

A family of inter-related products designed to aid the acoustic control of sound waves.

Acoustic performance is dependent on four factors, the profile of the tile, the surface structure of the broken air bubbles, the thickness and the density of the foam. The Acoustic Control series are based on a heavyweight foam designed specifically for acoustics, (not mattresses). The laws of physics dictate that absorption is directly proportional to density. The majority of other manufacturers tiles have a densities of between 10 and 30kg/cu metre so don't like to talk about it. Most of ours have a density of either 30 or 55kg/cu metre which in foam terms is a real heavyweight. That's why they out perform competitive products. The profile is not just designed to look aesthetically pleasing: the greater the surface area, the more tile there is to meet the soundwave. In consequence, deeper tiles have better absorption coefficients. The tile's surface when viewed through a magnifying glass reveals a series of ruptured air bubbles which in effect increases the surface area. Wall tiles come in various thickness. The thicker the material the better the low frequency absorption. That is why our Bass Traps have an effective thickness of over 240mm. Even our thicker wall tiles are 100mm deep. Studiospares 30 and 55 series tiles outperform all the competition.

If you need more information, please contact our technical sales team, who will be glad to help further.

Studiospares Acoustimax

Acoustic Tiles

Based on the highly successful Studiospares Acousticheck 30 tiles which use the heavyweight 30kg/per cubic metre foam.

- Effective on standing waves and flutter echo. Banish muddled sounds for ever
- High absorption of mid/high frequencies
- Computer controlled accurate profiling
- Fire retardant to UL94 HF-1
- Colour grey
- Competitively priced through zero wastage
- Size 500mm x 500mm



Four tiles shown with each turned through 90 degrees

10+ PRICE £8.80

30 kg/m³

Description	Code	Price (Ex VAT)
Acoustimax 50mm Grey	465-610	£9.80

Studiospares Pyramid 30 Wall Tiles

Acoustic Control

A really high performance tile which out performs any competition.

- Part of the Acoustitle 30 family using a genuine acoustic foam.
- Balanced absorption for low/mid and high frequencies.
- Minimises standing waves and flutter echos. Aesthetically pleasing.
- 49 square pyramids per tile
- Three thickness, 50, 75 and 100mm
- Meets UL94 HF-1 flammability tests
- All tile dimensions are 500mm x 500mm
- Colour Grey
- Simply glued to any surface
- Heavyweight foam, density 30kg/cu.mtr
- Sold singly

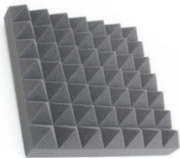

30 kg/m³

Description	Code	Price (Ex VAT)
50mm	465-580	£8.20
75mm	465-590	£11.30
100mm	465-600	£14.40

Quantity discounts apply

Studiospares Acoustitle Pro55

Wall Tiles

Acoustitle Pro55 brings a 55kg heavyweight foam to the audio industry...

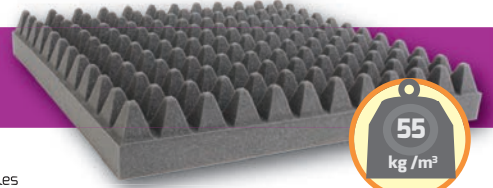

An industry first. Studiospares Acoustitle Pro55 brings a 55kg foam to the Audio Industry at a 30kg price. These tiles destroy reverberation putting you in control of the overall sound. Problematic low frequencies where the acoustic energy is the highest requires a high density foam to have any significant effect. Acoustitle Pro55 has the highest density of any commercially available tile which is reflected in its performance where it hits difficult lower frequencies head on. They feature a complex computer modelled profile to maximise the active surface area in contact with the sound waves. Shallow pyramid designs hardly increase the surface area rendering them less effective. Acoustitle's combination of height and profile yields a huge surface area which significantly increases the mid and high frequency absorption. Acoustitle Pro55 is a Polyester based Polyurethane foam. It has a uniform cell structure and better air permeability thus providing enhanced sound absorption over a wider range of frequencies. The chemical mix also includes fire retardants which achieves UL94 HF-1 approval. It is a genuine acoustic foam, not mattress or furniture foam. Competitive products use foams with a density of between 10kg - 32kg. Most manufacturers do not quote density figures but sell on hype. Size 500mm x 500mm. Colour grey.

Description	Code	Price (Ex VAT)
50mm Grey	465-460	1+ £7.50 10+ £6.75
75mm Grey	465-470	1+ £10.70 10+ £9.63
100mm Grey	465-480	1+ £13.90 10+ £12.50

No other Acoustic tile can match the Pro 55 performance.



Studiospares Acoustic Control Pyramid

Acoustic Tiles



30 kg/m³

Quantity discounts apply

Profiled and designed for vocal booth applications where frequency extremes do not exist. Vocalist will be in close proximity to the tiles which are profiled accordingly.

- Halts muddled sounds. Particularly effective at vocal frequencies
- Dims 500mm x 500mm. Heavyweight foam density 30kg/m³
- Total tile thickness is 50mm. Simply glued to any surface. Mid grey
- Fire retardant to UL94 HF-1.
- Sold singly

Description	Code	Price (Ex VAT)
Acoustic Control Pyramid 50mm	465-580	£8.20

Auralex Studiofoam Pro

Charcoal Panel

StudiofoamPro is the first melamine-free acoustical foam with a Class A fire rating.

- Offers a higher noise reduction coefficient (NRC =0.90) than 2" Studiofoam Wedges
- Beveled edges
- Competitive pricing for class A fire rating
- Won't degenerate like some other Class A tiles
- Exhibits the same reduced oxidation and long-lasting physical properties of Studiofoam
- Pro 2' Dimensions - 1.5" x 2' x 2'
- Pro 4' Dimensions - 1.5" x 2' x 4'

Description	Code	Price (Ex VAT)
Studiofoam Pro 2'	462-450	£20.79
Studiofoam Pro 4'	462-460	£41.50



Studiospares Acousticheck 30

Wall Tiles

Acousticheck 30 is based on a genuine acoustic foam which at this price out performs any competitive product.

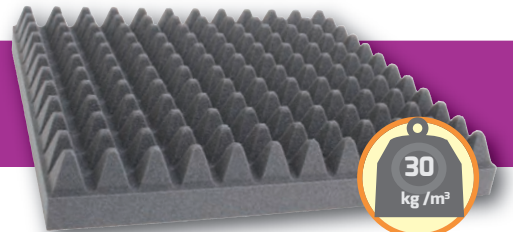

Mid and high frequencies are obliterated whilst low frequencies are well contained particularly by the 100mm version. The profile looks "Technical" because it is computer generated to maximise the surface area which in turn maximises the absorption. Low frequency performance depends on the foams thickness and density. At 30kg/cu metre this tile is only beaten by its sister, the Acoustitle Pro55. Problematic low frequencies (where the acoustic energy is the highest) require a high density foam like the Acousticheck 30 to have any significant effect. It has a uniform cell structure and better air permeability thus providing enhanced sound absorption over a wider range of frequencies. Competitive products have densities down to 10kg/cu metre which underlines the Acousticheck's superior performance. Most manufacturers do not quote density figures but sell on hype. The chemical mix also includes fire retardants which achieve UL94 HF-1 approval. Size 500mm x 500mm. Colour grey.

Description	Code	Price (Ex VAT)
50mm Grey	465-490	1+ £6.70 10+ £6.03
100mm Grey	465-500	1+ £9.80 10+ £8.82

Low price through being manufactured in the UK.



Auralex Sonoflat

Acoustic Tiles

Offer great absorption of mid to high frequencies

- Made of the industry-leading Studiofoam
- The edges are beveled, contributing to an elegant look not normally associated with acoustic foam
- Installed easily and arranged in a multitude of attractive patterns
- Equally at home in a recording studio or a home theater
- A cost-effective choice for accurate sound
- Dimensions 1" x 1" x 2"



Auralex Sonoflat Grid

Acoustic Panel

A great addition to any studio, home theater or listening room

- Design based on original SonoFlat™ profile
- Nine 8" x 8" beveled squares
- Overall NRC of 0.85
- Available in charcoal, purple & burgundy
- 2' wide x 2' long x 2" thick
- Easy installation using Foamtak™ Spray Adhesive or Tubetak™ Pro Liquid Adhesive
- Dimensions 2" x 2" x 2"

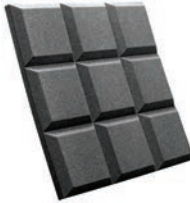

Auralex Studiofoam Wedges

Acoustic Tiles

Foam panel sizes 1200mm (4ft) x 600mm (2ft). Sold singly.



Designed to control mid and high frequencies. The cut on each panel is identical so matching adjacent panels is no problem. The foam is not surface painted and is the same colour all the way through.

- Effectively suppresses standing waves and flutter echos
- Best used in conjunction with thicker 100mm tiles to aid low frequency absorption. 100mm Studiofoam is ideal and has matching colours.
- Conforms to the Californian firecode which is more rigorous than UL-94 HF1
- Colours cannot be guaranteed to be fast as external factors such as humidity, sweat, sunlight, halogen and fluorescent lighting and cigarette smoke will all influence long term colour changes
- Available in 1200mm (4ft) and 600mm (2ft) size options

1200mm x 600mm x 25mm/50mm/100mm		
Description	Code	Price (Ex VAT)
Charcoal 25mm	462-380	£15.70
Purple 25mm	462-390	£15.70
Burgundy 25mm	462-400	£15.70
Charcoal 50mm	461-260	£24.90
Purple 50mm	461-270	£24.90
Burgundy 50mm	461-280	£24.90
Orange 50mm	461-285	£24.90
Charcoal 100mm	461-290	£45.83
Purple 100mm	461-300	£45.83
Burgundy 100mm	461-310	£45.83
Orange 100mm	461-315	£45.83



600mm x 600mm x 50mm/100mm		
Description	Code	Price (Ex VAT)
Charcoal 50mm	461-960	£11.30
Purple 50mm	461-970	£11.30
Burgundy 50mm	461-980	£11.30
Orange 50mm	461-990	£11.30
Charcoal 100mm	462-340	£21.50
Purple 100mm	462-350	£21.50
Burgundy 100mm	462-360	£21.50
Orange 100mm	462-370	£21.50



Auralex Wedgies

Acoustic Tiles

Wedgies are 303mm squares of 50mm thick Auralex Studiofoam.

- Great for spot treatment of studios and isolation booths
- Wedgies are available in Charcoal Grey, Burgundy and Purple
- Sold singly

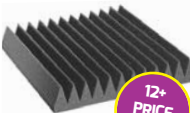

Description	Code	Price (Ex VAT)
Wedgies Grey x1	461-440	£4.75
Wedgies Burgundy x1	461-441	£4.75
Wedgies Purple x1	461-442	£4.75

Auralex Studiofoam Wave

Acoustic Panel

Helps control unwanted mid- or high-frequency reflections and standing waves in a variety of professional and residential applications.

- Unique new Wave profile offers numerous design possibilities
- Overall NRC of 0.80
- Controls harsh high frequency reflections and flutter echoes
- Appropriate for use in project studios, vocal booths, live rooms, listening rooms and home theaters.
- Dimensions 2" x 2" x 2"

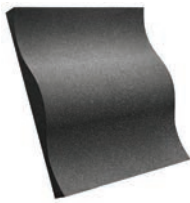

Auralex ProMAX

Acoustic Panel

Designed as a portable, lightweight, highly effective absorption treatment for run-and-gun recording and performances.

- Highly effective control of axial modes
- Tame chaotic reverberation
- Reduce unwanted acoustical reflections
- (2) 2'X4' Panels
- Semi-Reflective Rear Surface
- Adjustable Height w/included Mounting Stands
- Dimensions 2" x 4" x 3"



Description	Code	Price (Ex VAT)
Charcoal 25mm x2	462-770	£174.17
Burgundy 25mm x2	462-771	£174.17
Purple 25mm x2	462-772	£174.17

Auralex Studiofoam Pyramids

Acoustic Tiles

Made from the same high-spec foam as the Auralex Wedges but with slightly less foam mass.

- Perform about 85% as well as Wedges
- Available in Charcoal Grey, Purple, and Burgundy
- Two thicknesses to choose from: 2" (50mm) and 4" (100mm)
- Each tile is 2ft x 4ft (607 x 1214mm)
- Studiofoam Half Pyramids - As above but 607mm x 6007mm (2' x 2') and 50mm thick/100mm thick



Description	Code	Price (Ex VAT)
Pyramid 50mm Charcoal	461-340	£27.90
Pyramid 50mm Purple	461-350	£27.90
Pyramid 50mm Burgundy	461-360	£27.90
Pyramid 50mm Orange	461-365	£27.90
Pyramid 100mm Charcoal	461-370	£49.80
Pyramid 100mm Purple	461-380	£49.80
Pyramid 100mm Burgundy	461-390	£49.80
Pyramid 100mm Orange	461-395	£49.80
Half Pyramid 50mm Charcoal	462-000	£13.90
Half Pyramid 50mm Purple	462-010	£13.90
Half Pyramid 50mm Burgundy	462-020	£13.90
Half Pyramid 50mm Orange	462-030	£13.90
Half Pyramid 100mm Charcoal	462-410	£26.40
Half Pyramid 100mm Purple	462-420	£26.40
Half Pyramid 100mm Burgundy	462-430	£26.40
Half Pyramid 100mm Orange	462-440	£26.40

Auralex Pyramel

Melamine Foam

Specialist install foam for public buildings.

- Light Grey Only
- EU Class Fire rated - M1
- 24 Pack
- 586 x 586 x 45 cm panels per box
- Dimensions 586mm x 586mm x 45mm

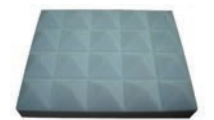

Description	Code	Price (Ex VAT)
Pyramel Light Grey x24	462-550	£495.00

Auralex Deskmax

Acoustic Panel

Can be used anywhere boundary-mounted acoustical treatments aren't feasible or desired.

- Portable nearfield acoustic treatment
- Improves low-frequency monitoring accuracy
- Helps with insufficient rear-wall trapping
- Excellent behind nearfield monitors
- Perfect for voiceover work, podcasts and more
- Convenient Travel Bag included
- Dimensions 2" x 2" x 3"



Description	Code	Price (Ex VAT)
Deskmax Charcoal x2	462-780	£124.17

MORE PRODUCTS online

ALL PRICES EXCLUSIVE OF VAT.

ACOUSTICS

Acoustic Tiles

CONTINUED

Universal Acoustics Tiles

Universal Acoustics absorption tiles are exclusively designed and manufactured in the UK. Cut in striking contemporary designs from a high density flame retardant Polyester foam. Perfect for use in Recording and Broadcast Studios, Music Rehearsal Rooms, Audio and language labs, Boardrooms, Offices, Staff rooms, Gymnasiums and any open spaces that require efficient sound absorption to improve the audio integrity and intelligibility plus the performance and dynamics of the room. Tiles can be glued directly to wall surfaces or ceilings or if preferred can be glued on to conveniently sized panels which may be hung or suspended as required. With this method they can be easily moved around or to a different location.

Jupiter Flat Faced Wedges

- 600mmW x 600mmD x 50mmH
- Profiled face
- Available in 4 colours: Purple, Grey, White and Burgundy

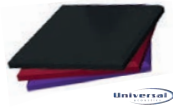

Jupiter Basotect Wedges

- 600mmW x 600mmD x 100mmH
- Fire Retardant Polyester material
- Density: 28-32 kg/m³
- Available in White



Mercury Wedges

- 300mmW x 300mmD x 50mmH
- General purpose tiles.
- Available in 3 colours: Purple, Grey and Burgundy

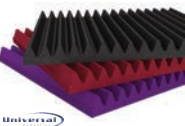

Mercury Basotect Wedges

- 600mm x 600mm x 100mm
- Ultra Fire Retardant Basotect foam material
- Class-O surface
- Available in White



Neptune Wedges

- 600mmW x 600mmD x 30mmH
- Bevelled edges
- Available in Grey



Description	Code	Price (Ex VAT)
Jupiter Purple	466-090	£24.50
Jupiter Grey	466-100	£24.50
Jupiter Burgundy	466-110	£24.50
Jupiter Basotect White	466-740	£43.50
Mercury Purple	466-270	£4.70
Mercury Grey	466-280	£4.70
Mercury Burgundy	466-290	£4.70
Mercury Basotect White	466-760	£55.50
Neptune Grey	466-570	£15.99
Neptune NW-CHA600-30	466-730	£14.50

Quantity discounts apply

Universal Acoustics Deep Bass Tiles

With low frequencies containing so much acoustic energy, the thickness of the absorption components becomes a major issue. This series includes components for both wall and corners.

Mercury Wedges

- A wall tile, architecturally designed to provide a striking modern image
- Flame-retardant polyester foam
- Density: 28-32 kg / m
- Flame retardant to UL94 HF1
- Dimensions mm: 600H x 600W x 200D

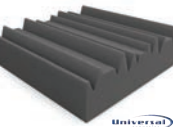

Description	Code	Price (Ex VAT)
Mercury Deep Bass Wedge x1	466-610	£45.00

Studiospares Antiverb

Acoustic Tiles



10+ PRICE £4.58

25 kg/m³

Primarily designed to provide a degree of absorption where a room is "just a bit bright". By simplifying the profiling we have managed to reduce costs.

This product will give good account of itself whatever the situation. More surface area to the sound waves increases the mid and high frequency performance. Dimensions 500mm x 500mm x 25mm. The Antiverb acoustic tiles are based on a fire retardant foam specially developed for the automotive industry. The density is 25-28kg/cubic metre which for a budget tile is a heavyweight. This is not some featherweight packaging foam made to look "technical". Sold Singly.

Description	Code	Price (Ex VAT)
Antiverb MK2	465-300	£4.98

Vicoustic Cinema Round

Acoustic Tile

Provides flexible and elegant solutions for sound control across a multitude of applications.

- Efficient absorption
- Easy to install
- Excellent value for money
- Performs mainly on medium and high frequencies
- Combines modern design with maximum acoustic efficiency
- Fabric-covered
- Dimensions: 600 x 600 x 75 mm
- Ideal for Listening Rooms, Home Theatres, Recording Studios



NEW

Description	Code	Price (Ex VAT)
Cinema Round x1	468-510	£21.50

Universal Acoustics Pyramid

Basotect is a thermoset so does not melt and produce burning droplets whilst emitting minimal smoke. Particularly suitable for applications with high fire safety requirements

Saturn Pyramid Tiles

- Meets national and international fire safety standards with the highest classification
- Light weight so can be easily secured by glue
- At low frequencies, improved sound can be made by adding layers of a heavier material
- Intended for absorbing mid and high frequencies
- Natural colour white.



Description	Code	Price (Ex VAT)
Saturn Basotect 50mm x1	466-680	£29.17
Saturn Basotect 100mm x1	466-690	£52.50

ACOUSTICS

Bass Traps

Vicoustic Super Bass Extreme

Bass Trap

The front panel is combined with a membrane, two high-density foam layers and a micro-perforated rear panel, with 1mm holes, that acts as a Helmholtz resonator.



- Perforations to give 20% more efficiency
- Highly recommended for smaller rooms with low frequency issues
- Membrane sympathetically vibrates over a frequency range of 75-85 Hz
- Based on Vicoustic's Wave Wood panel
- Provide effective low frequency absorption between 60-125 H
- Available in Cherry and White colour options

Description	Code	Price (Ex VAT)
Cherry Trap x1	468-500	£159.00
White x1	468-505	£159.00

Vicoustic Vari Bass

Bass Trap

Designed for use in any professional recording space, home studio, or hi-fi room.



NEW

- Made from wood and high-density acoustic foam
- Can be tuned between 50Hz and 100Hz by simply rotating its wooden top
- A scale is included to show the exact frequencies on which Vari Bass is acting
- Advised Units per Room Area: 7 to 11 m² - 4 Units (2 Box), 11 to 16 m² - 6 Units (3 Box), 16 to 22 m² - 8 Units (4 Box)

Description	Code	Price (Ex VAT)
Vari Bass x1	468-250	£195.00

Auralex Sonolite

Corner Trap

Designed to reduce unwanted reflections and flutter echo.



NEW

- A cost-effective alternative to fiberglass fabric-covered panels
- Covered in a velour fabric to add a stylish appeal to accent the decor of any room
- Tames chaotic reverberation
- EZ-Stick Pro Mounting Tabs included
- Made of Auralex's highly efficient absorbing acoustical foam, Studiofoam@Pro
- Dimensions 2" x 2" x 3"

Description	Code	Price (Ex VAT)
Black Corner Trap x1	462-760	£51.90
Tan Corner Trap x1	462-761	£51.90

VISIT our trade counter

You'll get friendly advice and immediate access to 8000+ product lines!

free parking for 40 cars

DELIVERY BEFORE 10AM no problem

Universal Acoustics Comet Corner Cube



Universal Acoustics Comet Corner Cubes are designed to be used in conjunction with the MBT600 and MTB600BD Bass Traps or as independent bass traps wherever as required. The Comet Corner Cubes are designed to provide realistic and affordable acoustic absorption and reverberation control within most types of rooms and spaces. Examples include Project Studios, Post Production facilities, Home Theaters, Home Studios, Rehearsal Rooms, Boardrooms, Language Labs, and Reception areas - in fact virtually any environment that would benefit from professionally designed sound control.

Description	Code	Price (Ex VAT)
Comet Corner Cube 300mm x1	466-620	£32.90

Universal Acoustics Deep Bass Traps

With low frequencies containing so much acoustic energy, the thickness of the absorption components becomes a major issue. This series includes components for both wall and corners.

Mercury Bass Trap

- Rear air gap to provide enhanced absorption
- Dimensions mm: 600H x 780W x 380D
- Density: 28-32 kg / m
- Flame retardant to UL94 HF1



Description	Code	Price (Ex VAT)
Mercury Deep Bass Trap x1	466-630	£124.50

Auralex Cornerfill 2"

Corner Trap

Smooths out the excess low frequency energy that congregates in room corners.

- Sections of flat-cut Studiofoam corner acoustic absorbers
- Gives you smooth, clean edges against which to butt your acoustic wall treatments
- Available in Charcoal and Purple
- Dimensions 2" x 2" x 24"



Auralex Cornerfill Cube

Corner Trap

A terrific way to finish out trihedral corners where three LENRD Bass Traps come together.

- Great for gyms and larger rooms
- Offer excellent bass absorption
- For both Cornerfill products suggested adhesive is 1 Foamtak or 1 Tubetak Pro
- Dimensions 1" x 1" x 1"



Description	Code	Price (Ex VAT)
Cornerfill Charcoal 2" x1	461-781	£2.25
Cornerfill Purple 2" x1	461-782	£2.25
Cornerfill Charcoal Cube x1	462-560	£31.50
Cornerfill Burgundy Cube x1	462-561	£31.50
Cornerfill Purple Cube x1	462-562	£31.50

Universal Acoustics Bass Traps

Universal Acoustics absorption tiles are exclusively designed and manufactured in the UK.

Jupiter Bass

- 320mmW across x 140mm front-back x 600mm high
- Available in 4 colours: Purple, Grey, Basotect White and Burgundy
- Sold singly

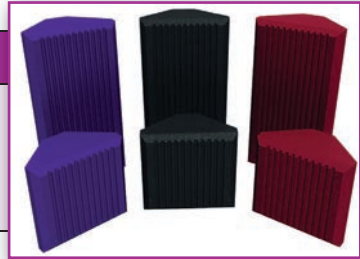

Mercury Bass Traps

- 320mmW across x 140mm front-back x 600mm high
- Available in 3 colours: Purple, Grey and Burgundy
- Sold singly



Neptune Bass Traps

- 320mm across x 140mm front-back x 600mm high
- Facia flat no profile
- Available in Grey
- Sold singly



Description	Code	Price (Ex VAT)
Jupiter Purple	466-000	£39.80
Jupiter Grey	466-010	£39.80
Jupiter Burgundy	466-020	£39.80
Jupiter Basotect White	466-420	£57.50
Mercury Purple	466-150	£40.83
Mercury Grey	466-160	£40.83
Mercury Burgundy	466-170	£40.83
Neptune Grey	466-580	£32.50

Cut in striking contemporary designs from a high density flame retardant Polyester foam. Perfect for use in Recording and Broadcast Studios, Music Rehearsal Rooms, Audio and language labs, Boardrooms, Offices, Staff rooms, Gymnasiums and any open spaces that require efficient sound absorption to improve the audio integrity and intelligibility plus the performance and dynamics of the room.



Auralex Metro LENRD

Bass Traps

XBased on the design of our original LENRD Bass Trap, the Metro LENRD gives a fresh look to a reliable sound absorber.

- Designed with a professional, architectural look
- A triangular-shaped bass trap that fits into room corners and/or wall/ceiling junctures
- Easily glued into position.
- Colour grey



Description	Code	Price (Ex VAT)
Charcoal x1	462-280	£29.70
Purple x1	462-290	£29.70
Burgundy x1	462-300	£29.70

Auralex LENRD

Low End Node Reduction Device

Bass frequencies congregate around edges and in the corners of rooms. Corners cause bumps in a room's frequency response, technically known as a Room Node.

- Size 300mm x 300mm x 600
- Conforms to the Californian firecode specification 117
- 600mm length mops up low frequencies
- Sold singly



Description	Code	Price (Ex VAT)
Charcoal	461-200	£31.50
Purple	461-210	£31.50
Burgundy	461-220	£31.50

ALL PRICES EXCLUSIVE OF VAT.

ACOUSTICS

Bass Traps

CONTINUED

Studiospares Corner Traps

Edge and Corner Bass Traps/Absorbers

NEW 55kg density Acoustic foam annihilates the competition by using a GENUINE acoustic foam.

It is a well known phenomenon that low frequencies are most prevalent in corners and around the edges. Killing these tangential low frequency nodes goes a long way to controlling low frequency problems. These tiles have a dramatic effect on low frequency booming. The deep wave pattern artificially increases the total depth of the tile so increasing low frequency absorption. Fire retardant to UL94-HF1. Glues to practically any surface. Computer controlled profiling assures consistency. UK manufactured using a Polyester based Polyurethane Acoustic foam. Dimensions 300mm sides x 500mm high.

Corner Traps Pro55 with our unique 55kg heavyweight foam. At low frequencies the heavier the foam, the greater the absorption. Nothing betters these corner traps.

Corner Trap 30 still outpaces any competition with it's lighter weight 30kg foam. Corner Traps and Cubes do not use mattress or furniture foam.

Corner Cubes allow for the junction of Corner Traps when they are mounted 90 degrees apart.



Corner Cube

Description	Code	Price (Ex VAT)
Corner Traps Pro 55	465-520	1+ £37.49 10+ £32.60
Corner Traps 30	465-530	1+ £17.40 10+ £14.80
Corner Cubes Pro 55	465-540	1+ £27.92 10+ £24.92
Corner Cubes 30	465-550	1+ £11.50 10+ £10.50

Please note.

Substantial Corner Cube price differential. To cut costs, the 55 version can be substituted for the 30 but note there may be a small colour difference.



Studiospares 55/30 Big Bass Traps



Low frequencies are high in energy and best tamed by our unique high density 55kg foam. Cost reduced lower density 30kg version (465-570) still out performs any competitive product.

- Wide Q factor so covers a wider frequency spectrum
- Much more cost/effective than active traps. Resonant style traps mainly effective at single frequencies. Foam traps effective on ALL frequencies
- Maximum depth 240mm. Length 500mm x 500mm wide
- Fire retardant to UL94-HF1

Description	Code	Price (Ex VAT)
Big Bass Trap 30kg	465-570	£41.20
Big Bass Trap 55kg	465-560	£54.40

Auralex DST-LENRD

Bass Traps

DST-LENRDs are a new 'Designer Series' LENRD alternative.

- Gives all the benefits of the LENRDs in an attractive new design
- Available in Charcoal Grey, Purple, and Burgundy
- Sold singly

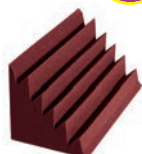

Quantity discounts apply

Description	Code	Price (Ex VAT)
Charcoal x1	461-450	£34.80
Purple x1	461-460	£34.80
Burgundy x1	461-470	£34.80

Vicoustic Super Bass 90

Bass Trap

Considered to be one of the best optimized solutions when treating low frequencies.

- Unique design allows you to minimize the dramatic effects that result from resonating waves
- Perfect complement to the Flexi Line absorption panels
- High efficiency absorption
- Easy to install
- Dimensions 300 x 420 x 600 mm
- Colour: Black
- Edges: Leveled
- Ideal for Listening Rooms, Home Theaters, Recording and Broadcast Studios and more



NEW

Description	Code	Price (Ex VAT)
Super Bass 90	468-550	£41.67

ACOUSTICS

Acoustic Room Kits

Universal Acoustics Corner Kits

Addresses the problem of bass frequencies causing the sound to be muddled. Low frequencies present the most problems because they are high in acoustic energy. This product absorbs such frequencies where they congregate, around edges and corners. Enough parts to cover two corners.

Mercury Corner Kit 1

- 6 x 300mm Bass traps
- 2 x Corner Cubes
- 1 x Space Mist 500ml



Mercury Corner Kit 2

- 6 x 600mm Bass traps
- 2 x Corner Cubes
- 2 x Space Mist 500ml



Description	Code	Price (Ex VAT)
Kit 1 Charcoal	466-640	£187.50
Kit 1 Burgundy/Charcoal	466-650	£187.50
Kit 2 Charcoal	466-660	£295.00
Kit 1 Burgundy/Charcoal	466-670	£295.00

Universal Acoustics Cluster Kits

A specially configured acoustic treatment kit designed to provide realistic and affordable acoustic absorption and reverberation control within most types of rooms and spaces. Provides a dramatic improvement to the audio integrity and sound definition, resulting in an altogether far less fatiguing and more comfortable acoustic environment.

Mercury Cluster Kit 1

- 14 x 300mm x 300mm Mercury Wedges 50mm thick
- 6 x Mercury Diffusors 50mm - 300x 300
- 1 x Space Mist adhesive spray (for foam)
- 1 x Cosmic Fluid cartridge adhesive (for polystyrene products)
- Install Guide



Jupiter Cluster Kit 1

- 20 x Jupiter Wedges 50mm - 300x300
- 6 x Mercury Diffusors 50mm - 300x 300
- 1 x Space Mist adhesive spray (for foam products)
- 1 x Cosmic Fluid cartridge adhesive (for polystyrene products)
- Install Guide



Description	Code	Price (Ex VAT)
Mercury Cluster Kit 1	466-710	£124.99
Jupiter Cluster Kit 1	466-720	£219.00

Acousti-Room Kit

A well conceived and balanced kit capable of obliterating mid and high frequencies AND maintaining good low end absorption using a genuine 30kg/cu.m. acoustic foam.

- Features 24x 50mm AcoustiMax (Code 465-610) and 8x 500mm AcoustiMax (Code 465-530)
- Bass traps for edges
- Minimises standing waves and flutter echoes.
- 500mm x 500mm

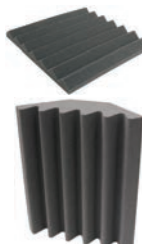

Description	Code	Price (Ex VAT)
Acousti-Room Kit	465-660	£299.00

WANT a job?

Are you looking for a stable and rewarding career?

Studiospares are constantly expanding. We require additional staff for a variety of positions, working in a very congenial atmosphere. Practical experience of recording and/or live sound engineering would be preferable.

send in your CV in the first instance

Universal Acoustics Mercury

Acoustic Room Kits

Universal Acoustics Solar Systems are specially configured acoustic treatment kits.

Auralex Roominators

Complete Room Kits



Roominators complete acoustic control kits are designed to make the job of improving the acoustics of your studio, control room, or home theatre, easy and affordable. Auralex even provide a chart in the Roominators section of their website (auralex.com) so you can easily work out which is the best kit for your size and type of room. Each kit contains Panels (Wedges or DSTs), LENRD Bass Traps, adhesive, and (Deluxe and Pro kits) T'Fusor 3D Sound Diffusers. Special order item - may take 6 weeks to deliver. Colour Charcoal Grey except T'Fusors which are White. Please enquire for further details or queries.

Deluxe Plus

- 24x Wedges 2' x 2' x 2"
- 8x LENRD Bass Traps
- 6 T'Fusor Sound Diffusers
- 5 tubes of Tubetak Pro adhesive



Pro Plus

- 6x Wedges 2' x 2' x 2"
- 12x LENRD Bass Traps
- 8 T'Fusor Sound Diffusers
- 8 tubes of Tubetak Pro adhesive

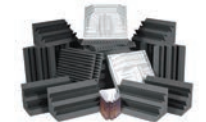

Alpha DST

- 32 300mm x 300mm x 50mm DST112s
- 32 300mm x 300mm x 50mm DST114s
- 4 LENRD-DST Bass Traps
- 3 TubeTak Pro Adhesive
- Available in 3 colour options



D36 DST

- 18x DST-112 in Grey
- 18x DST-114 in Grey
- 2 tubes of Tubetak Pro adhesive



D108L DST

- Ideal for smaller Home Theatres
- 54 300mm x 300mm x 50mm DST112s
- 54 300mm x 300mm x 50mm DST114s
- 8 LENRD-DST Bass Traps
- 6 TubeTak Pro Adhesive



Project 2

- Designed primarily for rooms with a floor square footage of <10sq m
- 24 Studiofoam 600mm x 600mm x 50mm (2x2x2") Wedge Panels
- 8 LENRD Bass Traps
- 5 Tubetak Pro Adhesives

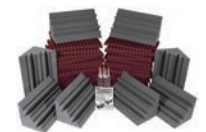

Mercury 1

- 20 x Mercury Wedges 50mm-300x300
- 2 x Mercury 300 Bass Traps
- 1 x Space Mist 500ml
- 1 x Install Guide
- Fire retardant



Mercury 2

- 40 x Mercury Wedges 50mm-300x300
- 4 x Mercury 300 Bass Traps
- 2 x Space Mist 500ml
- 1 x Install Guide
- Fire retardant



Mercury 3

- 20 x Mercury Wedges 50mm-600x600
- 4 x Mercury 600 Bass Traps
- 2 x Space Mist 500ml
- 1 x Install Guide
- Fire retardant

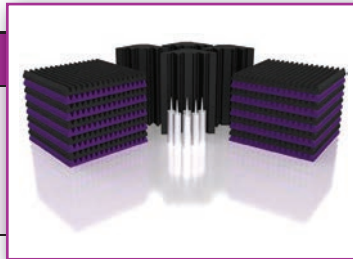

Description	Code	Price (Ex VAT)
Mercury 1 Charcoal	466-470	£145.00
Mercury 1 Charcoal/Burgundy	466-480	£145.00
Mercury 1 Charcoal/Purple	466-490	£145.00
Mercury 2 Charcoal	466-500	£295.00
Mercury 2 Charcoal/Burgundy	466-510	£295.00
Mercury 2 Charcoal/Purple	466-520	£295.00
Mercury 3 Charcoal	466-530	£499.17
Mercury 3 Charcoal/Burgundy	466-540	£499.17
Mercury 3 Charcoal/Purple	466-550	£499.17
Mercury 3 Basotect	466-700	£832.50

They are designed to provide realistic and affordable acoustic absorption and reverberation control within most types of rooms and spaces. Examples of usage include Project Studios, Post Production facilities, Home Theatres, Home Studios, Rehearsal Rooms, Boardrooms, Language Labs, and Reception areas - in fact virtually any environment that would benefit from professionally designed sound control. Dramatic improvement to the audio integrity and sound definition.



Auralex Room Analysis Plus Kit

Acoustic Room Kit

Helps you diagnose your acoustical problems

- Includes an omni-directional measurement microphone and a USB drive that includes frequency sweeps and step-by-step instructions on how to record this sweep in your room
- This recorded sweep will be sent back to Auralex via e-mail for further analysis.



Description	Code	Price (Ex VAT)
Room Analysis Plus Kit	462-570	£245.83

VISIT
our trade counter
You'll get friendly advice and immediate access to 8000+ product lines!
free parking for 40 cars

DELIVERY BEFORE 10AM
no problem

Description	Code	Price (Ex VAT)
Deluxe Plus	461-550	£662.50
Pro Plus	461-560	£813.00
Alpha Charcoal	461-570	£290.83
Alpha Charcoal/Burgundy	462-110	£290.83
Alpha Charcoal/Purple	462-120	£290.83
D36 DST Charcoal Grey	461-580	£92.50
D36 DST Charcoal/Purple	461-790	£92.50
D36 DST Charcoal/Burgundy	461-810	£92.50
D108L Charcoal	461-590	£495.00
D108L Charcoal/Burgundy	462-130	£495.00
Project 2 Charcoal	461-540	£412.50
Project 2 Charcoal/Burgundy	462-100	£412.50
Project 2 Charcoal/Purple	462-240	£412.50

ACOUSTICS

Acoustic Room Kits

CONTINUED

Auralex SonoFlat



Auralex's SonoFlat Systems offer an all-inclusive treatment option with a sophisticated architectural styling. The SonoFlat Systems offer all the great advantages of our industry-leading Studiofoam such as performance and longevity, and also provides you with a multitude of design possibilities for home theaters, recording studios, and other critical listening environments. The SFS-112 is best suited for rooms that do not need diffusion and the SFS-184 is best used in rooms that have at least one dimension greater than 12'.

SonoFlat SFS-112

- 24x 2" SonoFlat Panels (charcoal, burgundy or purple)
- 4x SonoColumns (Charcoal Only)
- 4x SonoCollars (Charcoal Only)
- 5x Tubetak Pro Adhesive



SonoFlat SFS-184

- 32x 2" SonoFlat Panels (charcoal, burgundy or purple)
- 8x SonoColumns (Charcoal Only)
- 8x SonoCollars (Charcoal Only)
- 6x QFusor Diffusers (water-based paintable)
- 12x Tubetak Pro Adhesive



Description	Code	Price (Ex VAT)
SonoFlat SFS-112 Charcoal	462-580	£540.00
SonoFlat SFS-112 Burgundy	462-581	£540.00
SonoFlat SFS-112 Purple	462-582	£540.00
SonoFlat SFS-184 Charcoal	462-590	£1125.00
SonoFlat SFS-184 Burgundy	462-591	£1125.00
SonoFlat SFS-184 Purple	462-592	£1125.00

ACOUSTICS

Acoustic Starter Kits

Studiospares Acoustic Starter Kit

Judged by any standards these starter kits offer a price/performance opportunity second to none.

Acoustic Starter Kit Plus Covers an area 1.5m x 1.5m Excellent low/mid frequency absorption from **4x** 75mm deep **Acoustitle Pro55** code 465-470 and **5x** 50mm deep **Acoustitle Pro55** code 465-460 mopping up the high frequencies.

Acoustic Starter Kit Pro Covers an area 1.5m x 1.5m **4x** of the outstanding 100mm deep **Acoustitle Pro55** code 465-480 obliterates low frequencies whilst the **5x** 75mm deep **Acoustitle Pro55** code 465-470 removes all traces of high frequencies. Tiles are best grouped at head height and facing the source of the sound.

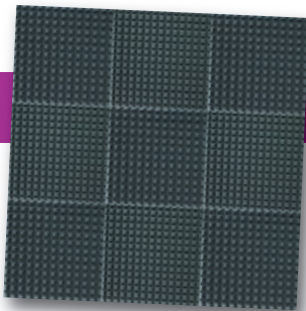

Description	Code	Price (Ex VAT)
Starter Kit Plus	465-640	£69.80
Starter Kit Pro	465-630	£95.30



UA Pluto

Starter System

Designed to provide realistic and affordable acoustic absorption and reverberation control within most types of rooms and spaces.

- Specially configured acoustic treatment kit
- 24 Mercury Wedges 300 x 300 x 50mm
- Includes an Installation Guide
- Fire retardant
- Colours Grey and Burgundy



Description	Code	Price (Ex VAT)
Pluto	466-560	£ 82.50

ACOUSTICS

Microphone Reflection Filters

SE Reflexion Filter

Vocalist Microphone Filter

Portable device for recording live sources with reduced room ambience.

- An advanced composite wall shielding the microphone from unwanted rear acoustic reflections
- Variable position stand clamp assembly included
- Helps obtain a 'dry' vocal or instrument recording
- Helps prevent any reflected sound reaching the back and sides of the mic



Description	Code	Price (Ex VAT)
Reflexion Filter	422-110	£140.83

Auralex AuralXpanders



A really useful kit to control external noise bleeds, off axis colourations and structural borne resonances. These items provide a solution by decoupling or shielding the microphone from the problem. Kit comprises:

1x **14" Xpander**, which slips over the cable or supporting holder and shields the rear of the microphone from rear reflections and unwanted sounds. Colour Grey.

2x **8" Tri-Xpanders**, protects the rear and underside from reflections and unwanted sounds. Colour Grey.

4x **6" Trap-Xpanders**, shields the rear end of vocal mics and instrument mics (especially drum mics). Hole diameter 25/30mm. Slips over the microphone body. Colour Grey.

6x **Platfeet**. Allows the recording engineer to reduce external noise bleed, structure-borne resonances reaching the microphone via the stand. Enough for two stands. Colour Grey.

Description	Code	Price (Ex VAT)
Auralex Xpanders Kit	461-680	£40.70

Studiospares RED 50

Microphone Sound Filter



An entry-level microphone filter offering a significant improvement in clarity when recording vocals.

A simplified design which is quick and easy to set up, the RED50 is also lighter than other alternatives, making it a highly portable solution you can take anywhere. Adjustable both horizontally and vertically, making it simple to get the perfect setup whether you're using a large or small microphone. Comes with a clamp to attach the RED50 to a mic stand. Dimensions 500 x 380 x 260 mm. Also available with a sturdy tripod stand

Description	Code	Price (Ex VAT)
RED 50	465-210	£41.66
RED 50 + Tripod Mic	465-215	£45.83

VISIT
our trade counter
You'll get friendly advice and immediate access to 8000+ product lines!
free parking for 40 cars

FOR
fax orders
Use our fax number...
020 8450 4390

THE
website
Keep up to date with all the latest products and current prices on the Studiospares website!
check out www.studiospares.com

Studiospares RED 100

Recording Enhancement Device

Provides a realistic answer to the problems of unwanted sound entering via the rear of the microphone.

The heart of the answer lies in the construction of the shielding material. Sound isolation rooms use the principle that sound waves agitate a material (the walls) and dissipate that energy into an acoustically absorbant material similar to Rockwool. RED 100 applies that principle by surrounding much of the microphone with a wall. In the case of RED 100 the wall consists of a complex sandwich construction of five differing materials. The results are astonishing providing better detail and a more accurate sound. To save storage space and provide more control over the captured sound the sides can be folded in and out. The unit is solid and heavy so the stand must have legs well splayed out otherwise it will fall forward. Round base stands are unlikely to be able to take the weight. The position of the microphone relative to the filter can be varied back and forth.



The RED 100 is intended to be attached to the top of a microphone stand via a standard 5/8" thread.



"The RED 100 worked out great as it cut out a lot of the ambient sound and gave a clear path for the guide vocal without too much over-spill from the near field monitor mix."

Bernie Shaw
Uriah Heep

Description	Code	Price (Ex VAT)	
RED 100	465-160	1+ £82.50	2+ £79.80
RED 100 + Floor Stand + Thread Adaptor	465-165	1+ £87.50	2+ £82.50

Studiospares RED 25

Mic Filter Diffuser Pack

An all in one package consisting of a screen to reduce rear borne sounds and an all metal pop filter screen.

- Both components are mounted on a bar which is clamps to the vertical mic stand
- 100mm slots in the supporting bar allow for flexible and accurate positioning
- Pop screen diameter 135mm
- Screen 178mmW x 152Hmm x 40mm deep



Description	Code	Price (Ex VAT)
RED 25	465-750	£28.50

Auralex Mudguard

Mic Isolator

Isolates your mic by eliminating external noise bleed and filtering out external overtones

- Engineered for maximum effectiveness using Studiofoam
- Reduces excessive room ambience and off-axis sound
- Mounts easily to most microphone stands and clips
- Size: 18"W x 15"H x 7.5"D
- Recommended by Sound On Sound magazine, October 2014 issue



Description	Code	Price (Ex VAT)
Mudguard	462-700	£65.83



Studiospares RED 40

Mic Acoustic Diffuser Screen



Initially intended as a screen to control the problem of cymbals spilling into drum microphones. Light weight design fits most popular instrument microphones. Protects the microphone against accidental "attack". Foam underside drastically reduces spill. Phase cancellation is reduced making performance optimisation easier.

Description	Code	Price (Ex VAT)
RED 40	465-320	£16.50

Studiospares RED 110

Instrument Microphone Sound Filter

The Studiospares RED 110 is a further development of the RED 100 and intended for instrument microphones. It is an affordable portable solution to improving the sound of the acoustic space surrounding the microphone.

- Microphone protrudes through screen
- Forward/back positioning adjustable
- Mic position held by crocodile clamp
- Multiple layer construction
- Reduces reverb and ambience



Stand NOT included

Description	Code	Price (Ex VAT)
RED 110	465-170	£39.00
RED 110 + Tripod Mic Stand	465-175	£45.00

Studiospares RED 20

Gooseneck Diffuser Screen

A really useful screen which can be mounted to suit many applications.

- Reduces sound waves reaching the mic and reduce sounds being reflected off rear walls
- Gooseneck 330mm long
- Clamps to microphone stand or pole
- Screen 178mmW x 152Hmm x 40mm deep



Description	Code	Price (Ex VAT)
RED 20	465-740	£20.82

DID you know?

At Studiospares we process all incoming orders within a few minutes

If anything is to be added to an earlier order, it will be processed as a NEW order.

ACOUSTICS

Sound Diffusors

Auralex Sound Diffusors

T'Fusor 3D

- Made from lightweight yet sturdy high impact thermoplastic
- Easy to mount, fitting into ceiling grids or with Tubetak, Velcro, nails, etc, and are easily painted
- Hollow back can also be filled with foam, Sheeblok, fibreglass etc
- Size 600mm x 600mm x 150mm thick
- Colour White



Minifusor

- A smaller version of the T'Fusor
- Made of rigid thermoplastic resin, and is easy to paint and mount
- Size 304mm x 304mm x 123mm High
- Ideal for small rooms
- Best filled with any soft material, wool, cotton, carpet bits etc
- Colour White



DST-R

- The Auralex Diffusive Sound Tile Reflector (DST-R) is 304mm x 304mm
- Cut in the same shape as the DST-114 tiles, except it is only 25mm thick
- Great option if space is limited
- Made from high-quality Class A flame retardant EPS (expanded polystyrene)
- Colour White
- Illustration shows a single tile plus four laid to form a pattern.



Metrofusor

- Made from high-quality Class A flame retardant EPS (expanded polystyrene)
- Light, affordable, easy to paint and easy to mount
- Features a distinctive proprietary attractive surface contour
- Size 600mm x 600mm
- Colour White
- Sold by the box of 12 tiles



Quadfusor

- Addresses standing waves and flutter echo without removing acoustic energy
- Enhance the accuracy of critical listening environment
- Create a larger sweet spot
- 'Class A' Rated
- Paintable White
- Dimensions 2' x 2' x 4.5" Deep



Description	Code	Price (Ex VAT)
T'Fusor	461-610	£39.30
Minifusor	461-620	£9.75
DST-R	461-640	£3.54
Metrofusor	461-690	£149.00
Quadfusor	462-640	£47.50

Auralex Quadratrec

Diffusors

Provides excellent scattering properties, resulting in a warm, musical character to the dispersed sound.

- A nested pair, giving you two unique diffusion tools that when used in combination with each other can result in a more spacious feel in any room
- Lightweight design
- Can be placed in suspended ceiling grids or attached to wall surfaces with mechanical fasteners
- Size: 23.75" x 23.75" x 4.1"



Description	Code	Price (Ex VAT)
Quadratrec x2	462-680	£415.83

Universal Acoustics Mercury Diffusor

Sound Diffusor

Available in 300mm and 600mm square sizes. Their flat surfaces are 50mm thick but include peaks and dips between 20mm and 80mm high to achieve their hard surfaced diffusion properties.

- Fire Retardant EPS (Expanded Polystyrene) to Class 3 fire specification
- Can be painted any colour with water based emulsion
- Effective low cost solution for dull rooms
- Finished in Standard White



Description	Code	Price (Ex VAT)
Diffusor 300 x 300	466-360	£5.82
Diffusor 600 x 600	466-750	£19.00

Auralex WaveLens

Diffusors

Scatters and redirects acoustical energy and can be an effective alternative to absorbing reflections.

- Creates a "large sound" in a small room
- Optimizes absorption panels by redirecting energy so that they are more efficient
- Sized to drop into a suspended ceiling grid
- Can also be installed using the supplied mechanical fasteners
- Enhances your listening or recording environment
- Size: 23.75" x 23.75" x 3"



Auralex Wave6 Kit

Diffusors

A set of 6 WaveLens that includes connecting hardware to install in various patterns.

Description	Code	Price (Ex VAT)
WaveLens x2	462-660	£275.00
Wave 6 Kit	462-670	£707.50

Auralex WavePrism

Diffusors

Eliminates flutter echoes and other acoustical anomalies without removing acoustical energy from the space.

- Disperses sound evenly to create a more consistent listening or recording environment
- Sized to drop into a suspended ceiling grid
- Can also be installed using the supplied mechanical fasteners
- Size: 23.75" x 23.75" x 3"



Description	Code	Price (Ex VAT)
WavePrism x2	462-650	£332.50

ACOUSTICS

Acoustic Glues + Aerosols + Foams

Acoustic Acrylic Mastic 310ml



A one part fire rated intumescent acrylic mastic.

- Designed for sealing gaps around fire doors, window frames and for sealing joints, voids and irregular holes in fire rated structures
- Tested in accordance with BS476: Part 20 & 22; PR EN1366-4, LANTAC Building Control Approval and NHBC Type Approval
- Can be used on most construction substances, although we do recommend that a small area is tested on unusual substrates

Description	Code	Price (Ex VAT)
Acrylic Mastic	635-220	£5.20

Auralex Stopgap

Acoustic Sealant



Fast-setting gap filling adhesive.

- Ideal for reducing sound transmission at any joints or at the edges of walls
- Surface dries to a tough, paintable film but the sealant remains flexible for much longer than some other brands
- Comes in a large 800g tube requiring a large-sized caulking gun (Code 635-480)
- Covers approximately 12sq m with a 3/8inch bead applied

Description	Code	Price (Ex VAT)
Stopgap	461-820	£19.80

WANT a job?

Are you looking for a stable and rewarding career?

Studiospares are constantly expanding. We require additional staff for a variety of positions, working in a very congenial atmosphere. Practical experience of recording and/or live sound engineering would be preferable.

send in your CV in the first instance

1000s of products Available from stock!

PDF catalogue

Want this catalogue on your phone or laptop?

The Studiospares catalogue is now available in PDF format.

visit www.studiospares.com/page/pdfcatalogue/

MORE PRODUCTS online

Auralex Tubetak/Foamtak

Spray Adhesives

Tubetak Pro Liquid Adhesive

A super-strong, water-based adhesive which applies easily with a standard caulking gun.

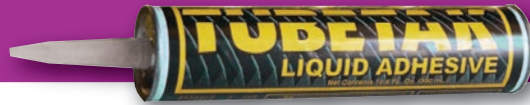

Provides a permanent bond and 1 tube mounts up to 2.9 square metres (32 square feet) of foam or diffusers, depending on thickness. Auralex guarantee that Tubetak Pro will not oxidise Auralex foam products.

Description	Code	Price (Ex VAT)
Tubetak	461-660	£13.90

Foamtak Spray Adhesive

The fastest and easiest way to mount Auralex foam products.



Unlike Tubetak Pro, which is more permanent and tougher to remove later, Foamtak can be applied lightly so that your foam is removable, or it can be applied heavily for a more permanent bond. Not suitable for use with MetroFusors or DST-Rs. Mounts up to 8.7 square metres (96 square feet) per can depending on foam thickness.

Description	Code	Price (Ex VAT)
Foamtak	461-650	£19.90



Green Glue

Visco-Elastic Damping



A revolutionary sound proofing material which is proving very popular amongst acoustic industry professionals.

- Works well as part of any standard stud wall
- Can be added to existing walls, floors and ceilings without needing to remove existing materials

Description	Code	Price (Ex VAT)
Single tube	635-500	£12.95
12 Pack	635-510	£139.00

Webbgrip Adhesive

High Strength



Fast-setting gap filling adhesive.

- Designed to permanently bond most common building materials
- Can be used on insulation materials (not polystyrene), and many plastics, metals and ceramics
- Use with a standard caulking gun
- Sets rapidly and achieves full bond strength in 48 hours

Description	Code	Price (Ex VAT)
Webbgrip	635-490	£7.24

Universal Acoustics Space Mist

Adhesive

A high strength aerosol adhesive with the advantage of a variable spray width button.

- Especially developed and formulated for acoustic foam materials
- Fast drying high strength bond



Description	Code	Price (Ex VAT)
Space Mist	466-410	£12.80

CAUTION!

Please note that aerosols cannot now be sent by Royal Mail. Courier delivery only.

Universal Acoustics Cosmic Fluid

Adhesive



Perfect solution for mounting acoustic foam materials.

- High quality gun grade, high bond strength synthetic rubber /resin adhesive
- High initial grab
- Good gap filling properties

5+ PRICE £9.50

Description	Code	Price (Ex VAT)
Cosmic Fluid	466-400	£10.70

ASTROflame

Fire Rated Acoustic PU Foam



A polyurethane foam which expands to fill and seal gaps.

- Note: This product is fire rated but is not intumescent
- Once set, it forms a strong bond to most building materials such as wood, brick, stone, cement, plaster, polystyrene, metals and many plastics
- Acts as a fire seal in accordance with BS476 Part 20 and meets Class B1 of DIN 4102 Part 1
- Storage life 9 months. 700ml

Description	Code	Price (Ex VAT)
ASTROflame	635-210	£16.50

Vicoustic Flexi Glue

Designed for use with a variety of materials.

- Non aggressive chemical composition
- Certified in accordance with the most recent European legislation
- Perfect for use with polyurethane (foam) or polystyrene (EPS) Vicoustic solutions
- Excellent strength and versatility when applied to a range of materials



Description	Code	Price (Ex VAT)
Flexi Glue x1	468-520	£11.60

Auralex Temp Tabs

Provides a temporary moun solution for foam tiles.

- No need to commit tiles to permanent position
- Great when moving tiles ar find the best location
- Pack contains 72 pads and adhesive



5+ PRICE £37.70

Description	Code	Price (Ex VAT)
Temp Tabs	461-740	£39.60

PRICE changes

This catalogue was priced on 1st December 2014.

Current prices may be higher...

see our website for up to date prices.

THE website

Keep up to date with all the latest products and current prices on the Studiospares website!

check out www.studiospares.com

VISIT our trade counter

You'll get friendly advice and immediate access to 8000+ product lines!

free parking for 40 cars

Methods and Costs of Carriage

FREE DELIVERY We are currently offering free standard delivery (2 to 5 days) on orders to GB mainland (not highlands and islands) on all orders over £99. This is subject to change and may be amended at any time. Check our website for the latest information. Otherwise costs are as follows:

Mainland GB (not Highlands and Islands). Orders of less than £25 and 1kg in weight can be sent first class letter post for £3.00 + VAT. Orders over £25 or over 1kg will be sent DPD or UPS and charged as follows for each 20kg or part up to 20kg:

STANDARD delivery up to 5 working days	£5.00
EXPRESS Next working day delivery (for orders received before 3pm)	£7.00
Next working AM before 12 noon (for orders received before 3pm)	£13.00
Next working AM before 10am (for orders received before 3pm)	£20.00
Saturday delivery Please order as early as possible.	£25.00

European Union inc. Ireland. Flat rate charge for up to 2kg or £100. E6 Delivery 3-10 working days. Uninsured Delivery. (NB Greek, Portuguese and Spanish islands excluded). Alternatively, for heavier or more expensive parcels, please refer to the following chart (normally a 2 to 4 day delivery, and does not apply to deliveries of acoustic tiles or screens, Rockwool, Computer desks, workstations or Esmono rooms):

	0-20kg	21-40kg	41-60kg
Belgium, France, Germany, Netherlands	£24	£40	£50
Spain, Italy, Portugal	£26	£43	£54
Finland, Austria, Sweden, Denmark	£28	£46	£57
Switzerland, Norway	£38	£55	£60

Highlands, Islands, N.Ireland Channel Islands, IOM and Scilly Isles. Next day delivery is difficult without considerable expense. Standard 2-3 day delivery with weights up to 20kg costs £10.

Outside European Community. We ship worldwide at preferential rates. Please ask for a quote.

Parcels are sent uninsured at the client's risk. Insurance is very expensive. In ten years, lost parcels have not exceeded £2800 in total.

Website Orders are treated very much like any other order at Studiospares. Do check back regularly for the latest offers.

Web Order Confirmations. When our system receives your Web Order, it will send you a confirmation email. This email simply confirms that we have received your order, and does NOT amount to a contract between Studiospares and yourself. The contract will be entered into at the point of despatch of goods when we raise a Sales Invoice for the sale of the goods being despatched.

Same Day Deliveries

Same Day. We ship locally via bike or van, or to distant destinations. Customer to pay all costs. No freight company GUARANTEES same day delivery but couriers will be 99% certain. Orders need to be received by 3pm.

Collection of goods by an Account Holder

For security reasons, Account customers will need to provide a faxed order before collecting, and bring the original order with them. Previous employees sometimes take liberties.

Credit Card orders by telephone

The Credit Card companies insist that if clients wish to collect goods from the Trade Counter, it is the card holder who must collect and sign. If we are sending goods, they can only be sent to the card holder's address which is verified with the card company before despatch.

Methods of payment

Cash, Cheque, Access, Visa, Switch, EuroCard, Master Card, Direct Transfer to Bank. **Now also accepting Paypal.** Cheques must be cleared and can take up to 7 days to do so. Credit Card transactions by phone or letter will require the Expiry Date as well as the card number. Goods can only be sent to Card Holder's address which is verified before despatch.

Duplicate Orders

Corporate clients frequently back their telephone orders with written confirmation. **Unless the faxed or posted confirmation order is clearly marked 'Confirmation'**, as such we would treat the order as an original and process it in the normal way. In such an event Studiospares reserve the right to charge the client for duplicated carriage charges and levy a 10% restocking charge. We do not guarantee to repurchase these goods from our clients particularly if the goods were non-catalogue items.

Refunds

We are prepared to purchase goods back from customers providing all the following criteria are met. Customer to pay all carriage costs both from and to Studiospares. Goods to be returned within 7 days. Original invoice must accompany goods. Goods to be packed in original carton complete with all documentation and totally unmarked. The item's carton not to be overwritten or damaged. Opened software and cut lengths of cable are excluded; full reels only. Your statutory rights are not affected. **Studiospares reserves the right to decline repurchasing goods, subject to your legal rights being protected.**

Price Changes

Studiospares endeavours to hold the catalogue price for the life of that catalogue. However although many prices have fallen, many others are rising significantly. For this reason, we cannot guarantee catalogue prices. We advise customers to always check online for up-to-date prices.

Discounts

Everyone in our industry is in "The Trade". Practically all Studiospares prices are heavily discounted. Some prices are just a few % above our buying in price. We supply huge purchasing organisations, dealers, schools, charities and acknowledge that such purchasers should pay less if they are purchasing larger quantities. Therefore quantity discounts apply to all products and are shown under that item's code number. We run a very efficient operation so have lower running costs. We prefer to pass these savings on to the customer. To obtain our actual selling price simply phone and quote the product's code number. Our actual selling price is whatever the computer shows and everyone pays the same price.

Liability

The customer will be responsible for ensuring the goods fit the purpose of the application. Studiospares endeavours to ensure that the information given in this catalogue is correct. We accept no liability in respect of loss arising from errors in the information provided. In no event shall any breach of contract or tort or negligence or failure of any kind on our part or that of our employees be accepted as liability for loss of revenue or consequential loss or damage arising from any cause whatsoever.

Returns Policy (Abbreviated)

Studiospares Customer Returns Policy.

Our aim is always to work with our customers to sort out any problem quickly and to ensure total customer satisfaction with the products we sell. Full information is included on our website, www.studiospares.com

The Distance Selling Regulations 2000(DSR)

The Right to Cancel puts responsibilities on both the purchaser and seller when a consumer purchases by mail order or over the Internet. Customers have the right to cancel an order within 14 working days of receipt of goods. Customers will be required to return the goods at their own expense and liability, unused and as new, complete with all accessories, cables, manuals, and software in undamaged, unmarked and original packaging. Goods must be protected for transit by a double box or cardboard outer. Proof of purchase must be provided. Credit will only be issued on receipt and inspection of the returned goods. Please note that the following are not covered under the Right to Cancel: Recordable media, computer software. Due to health and safety considerations microphones, microphone pop filters, headphones and IEM systems will only be accepted in unopened, security-sealed packaging. "Customised" orders, including cut lengths of cable, custom looms and non-stock special order items are also exempt. Goods purchased from the Trade Counter are not covered by the DSR.

Defective Items (Warranty repairs and Guarantees)

Please contact our returns department on 020 8208 9951 or returns@studiospares.com to arrange your return and be issued with a Returns Number. Studiospares can arrange collection of items returned for warranty repair or replacement, provided goods are returned in the original packaging within our 12 month warranty period. However, carriage charges are payable for return to a customer for an item found not to be faulty or if the damage is not covered by the warranty. No liability will be accepted for goods returned in unsuitable packaging. Warranty provisions do not cover normal wear-and-tear or consumable items such as DJ mixer cross faders, turntable styli, or recordable media. Loudspeakers and power amplifiers are not covered by warranty if overdriven or misused in any way.

Within 28 days from receipt of goods: No quibble exchange or refund providing that the fault or damage has not been caused by the neglect or misuse of the customer. An explanatory note is required, detailing the suspected problem, also proof of purchase. Goods must be returned in their original packing complete with all accessories. Replacements or refunds will not be made until the original goods have been received by us.

After 28 days and before 12 months from receipt of goods: Goods must be returned to Studiospares for inspection and repair. There is no right to an immediate replacement. If upon inspection, the fault is found to be outside of the manufacturer's warranty conditions, a charge will be made for the repair of the goods and their subsequent return.

Damaged Goods / Errors

If you believe that an order may have been damaged in transit to you, please sign for it as "damaged" to the carrier, or refuse to accept the delivery. If you accept a damaged delivery, you must retain all original packaging for examination. You must notify Studiospares of any damage within 24 hours of receipt of goods. You must notify Studiospares of any error in orders within 3 days of receipt of goods. Please contact our returns department on 020 8208 9951, fax 020 8450 4390 or email returns@studiospares.com.

Times and Dates of Opening

Monday to Friday 8.30am to 5pm, Thursdays til 8pm. Voicemail on at all other times on 020 8208 9930. Closed Bank Holidays, plus 24th and 29th December 2015. Open 9am-3pm on 30th and 31st December 2015.

Telephone Numbers

Sales	020 8208 9930
Fax Administration	020 8450 4390
Fax Sales only	0800 731 3767

Bank information

Barclays Bank. 54 High Street, Ruislip, Middlesex HA4 7AT.
Sort Code 20-73-53 Account No 60824046

Studiospares VAT Number

GB 393 7850 07

Studiospares PRICE MATCH

Studiospares **PRICE MATCH** policy means we promise to beat any genuine price offered by UK competitors on any item or order from our catalogue.

How does it work?

We try to make all our prices highly competitive, but if you find one of our products in stock elsewhere in the UK at a lower price, simply tell us and we will beat that price. Please be ready to tell us the name and telephone number of the company where you saw the lower price.

Are there any exceptions?

Studiospares will endeavour to make NO exceptions. However occasionally certain outlets grossly overstock a product and then have to sell at a loss or sell off end of line products proclaiming 80% off! Studiospares cannot promise to sell at a loss; where a competitor's price is below our buying-in price, we may be obliged to offer a 'best possible deal' instead of matching the price. Please phone to avoid any disappointment.

Studiospares is an equal opportunity employer

Studiospares endeavours to make sure this catalogue contains no errors. If errors do exist, we reserve the right to sell at whatever price prevails at that time. E & OE.

Mainland GB (not Highlands and Islands) Deliveries

Orders of less than £25 and less than 1kg in weight can be sent first class letter post for £3.00 + VAT **uninsured**. Includes ALL UK Postcode addresses.

Orders over £25 or over 1kg will be sent DPD or UPS. Each 20kg or part thereof will be considered as 1 parcel and charged as follows:

Same Day Delivery by arrangement.

Highlands, Islands, Republic of Ireland, and N.Ireland. Next day delivery is not normally possible. Normal transit time 2-3 days costs £10 service for parcels weighing up to 20kg. All parcels sent via DPD have limited insurance.

Up to 5 working days	£5.00
Next working day delivery (8am - 6pm)	£7.00
Next working day delivery before 10am	£20.00
Next working day delivery before 12 noon	£13.00
Saturday delivery	£25.00

For timed delivery, orders must be received before 3pm.

Scottish Highlands and Islands, Republic of Ireland, Northern Ireland, Channel Islands, Isles of Scilly and Isle of Man

Standard 2-3 day service for parcels weighing up to 20kg £10.00

EC Countries

£6 flat rate charge for up to 2kg or £100. Delivery 3-10 working days via Royal Mail. (Portuguese, Greek and Spanish islands not included.) Freight cost of urgent deliveries will be charged at our cost.

Parcels up to 20kg from £24. (more info opposite)

Express service is also available - please request a quotation.

Rest of the World

We ship worldwide by whatever means the clients prefer. We obtain preferential rates and pass these on to clients.

Insurance is optional and very expensive. In ten years, where goods were shipped to the local agent, lost parcels have not exceeded £2800 in total.

All Studiospares prices are Ex Works London. In areas where there are conflicts or communications are difficult we usually ship to our local agent at the airport. Customers can collect or arrange delivery their end.

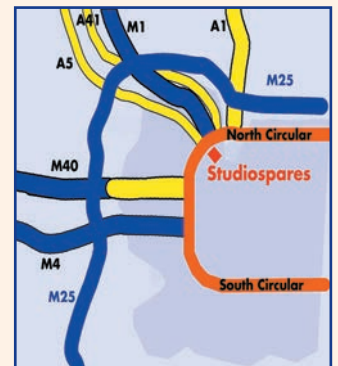

How to find us

By Road

Travelling on the North Circular or A5 exit at the A5 Staples Corner junction. **Do NOT use the flyovers**. Take the A406(W) North Circular Road heading West. **We are located on the slip road**. Passing the Big Yellow Storage warehouse take the second turning on the left at the junction of Waterloo Road. Our Car Park is the first entrance on the right in Waterloo Road.

How to find us

By Public Transport

964 North Circular Road is approximately one mile from NEASDEN on the Jubilee Line to the west, BRENT CROSS on the Northern line to the east and CRICKLEWOOD on British Rail to the south. All Staples Corner bus stops are within a three minute walking distance of our premises. On average buses pass these stations to within 500 metres of our premises every two minutes. From the Staples Corner roundabout walk uphill along the North Circular (A406W) heading west past the Big Yellow Storage depot. We are 300 metres on the left and actually on the North Circular Road.

Studiospares Ltd
 964 North Circular Road,
 Junction of Waterloo Road at Staples Corner,
 London NW2 7JR
 Tel 020 8208 9930



Microphones	Condenser	86-94	Monitors (Studio Speakers)	153-161	Recorders	4-9	T		
	Directional (Highly)	114-115	Monitor Pads	301-302	Reflection Filters	314-315	Table Mic Stands	186-187	
	Drumkit	101-103	Monitor Pads	301-302	Reverbs	35	Tape	Gaffer	293
	Dynamic	98-110	Multicore Cable	220	RFI Filters	227		Insulation (PVC)	225
	Headworn	115	Multi Effects Processors	38	Ribbon Microphones	96-97		Masking	293
	Installation	111-112	Multimeters	294	Routing Box	244		Self Amalgamating	225
	Instrument	98-103	Multipoise Mic Stands	183-184				Stage Guide/Striped	293
	iPhone	97-98	Multitrack Recorders	11	S		Tape (Magnetic)		17
	Lavalier	113	Multitray Connectors	231	Samplers	82	Test Equipment		294-295
	Modular	103	Music Stand Lights	194-195	Screens, Acoustic	305	Testers, Cable		228, 295
	Measurement	115	Music Stands	183-193	SD Cards	15	Thread Adaptors (mic)		133
	Radiomics	116-123	N		Security Covers (Rack)	289	Tiles	Acoustic	307-314
	Reporting	114	Neoprene Strips	304-305	Service	292-294	Tools		296
	Ribbon	96-97	Noise Gates	32	Sheetblock Sound Barrier	304	Transformers Mic		135
	Shotgun	113-115	Nuts (Cage)	288	Signal Distribution	37-38, 74	Trolleys, Rack Equipment		285
	Smartphone	97-98	O		Snakes	272-274	Tuners	AM/FM Radio	42
	Speech	116	On Air Signs	294	Software	83-84		Pitch Tuning	209
	Stereo	112	Optical	Adaptors	Solder and Soldering	296	Turntables		48
	USB	95-96		Adaptors	Soundcards (see 'Audio Interfaces')	69	Turntable Accessories		48
	Valve/Tube	94		Converters SPDIF-AESEBU	Sound Deadening Felt	304	U		
	Video Camera	113-114		Leads	Sound Diffusers	316	Ukuleles		202
	Vocalist	104-109	P		Sound Enhancers (Outboard)	35-36	Underlay, Sound Deadening		304
	Wireless	116-123	PA Speakers	163-170	Sound Level Meters	294	USB	Audio Interfaces	62
Microphone Accessories				PA Packages	Sound Modules	82		Card Readers	16
	Attenuators	135			SPDIF Leads	264		Leads	268-269
	Bags	182	Patch	Bays	Speakers	163-177		Microphones	95
	Booms	183		Cords / Leads	Speaker			MIDI Interfaces	68
	Cable	218-220	PC Card Recorders	9-10		Accessories		Pen Drives	15
	Cases	279-280	Pedals	211		Bracket			
	Clips/Suspensions	128-130	Pen Drives (USB)	15		Cable			
	Fishpoles	184	Percussion	214		Isolation			
	Goosenecks	129	Phantom Power Supplies	132-133		Leads			
	Holders/Clips	129-131	Phono (RCA)	Adaptors	Plugs/Connectors	237-238			
	Hygiene	131		Leads	Stands	188			
	Leads	250-254		Plug/Connectors	Switchers	162-163			
	Phantom Power Supplies	132-133	Pianos / Synths	81, 211		Wall Brackets			
	Pop Screens	125	Pliers	296	Speakloc Plugs	238			
	Pre Amps	39-42	Pop Screens, Microphone	125	Speakloc Leads	266-267	V		
	Problem Solvers	134	Portable PA	28	Speakon Adaptors	243	Velcro (Hook n Loop)		292
	Splitters/Combiners	133	Portable Recorders	4-9	Speakon Leads	266	Video	Cable	222
	Stands	178-187	Portable Sound Booths	30-301	Speakon Plugs / Connectors	237-238		Camera Mics	113-114
	Supports	182-184	PortaStudios (Recording)	9	Stage Boxes	230		Leads	270
	Suspensions (Elastic)	128-129	Power Amps	42-46	Staging	297	Vocal Booths		299
	Transformers x8 Rack	135	Power Conditioner/Sequencer	248	Stage Performing Tape	293	W		
	Windshields/Screens	124-127		Distribution	Stands	Bags	182, 276-278	Wall Boxes	229-230, 292
MIDI	Controllers	77-78		Supplies		Guitar		Wall Brackets	162, 192
	Interfaces	76-77	Powered Mixers	27		iPod		Wall Panels (Acoustic)	305-306
	Keyboards	78-80	Preamplifiers	39-42		Keyboard		Wall Worts (Low voltage Power Supplies)	249
	Leads	267	R			Laptop		Washers/Nuts/Bolts (Rack)	288
	Plugs/Connectors	237	Rack (19")	Bags		Microphone		Wind Instruments	214
MiniDisc	Media	16		Bolts/Nuts		Music		Windshields	124-129
	Recorders	11		Cases		Speaker		Wireless Microphones	116-124
Mini Jack Leads		261-262		Drawers		Table (for Mic)		Wiring Looms	270-271
Mini Jack Plugs/Connectors		236		Housings/Cabinets				Wordclock Leads	263
Mini XLR (Tiny XLR) Plugs/Connectors		234		Lights		Stereo Bars		X	
	Leads	254		Patch Panels/Bays		Stools		XLR Accessories	
Mixers	Analogue	21-27		Rackstrip		Stringed Instruments			Adaptors
	Cases/Bags	280-282		Trays		Strings, Guitar			Leads
	Digital	17-21		Trolleys		Studio Monitors			250-254
	DJ	50-52		Ventilation		Studio Monitor Accessories			Plugs / Connectors
	Powered	27-28		Radiomics		Surge Protectors			231-239
	Zone	28		Receivers, Radio Tuners		Suspension Mounts, Microphone		Y	
Monitor Controllers		162-163				Synthesisers		Y Splitters/Y Leads	265
								Z	
								Zone Mixers	28



Akai MPK 25 Keyboard Controller

Code 266-060 £145.83

Engineered to be an all-in-one controller solution, the MPK225 features 25 semi-weighted keys with aftertouch, 8 MPC-style pads with RGB feedback, 8 assignable knobs, 4 backlit buttons, and onboard transport buttons.



Tascam CG-2000 Master Clock Generator

Code 238-700 £2112.50

With redundancy of both the power supply and the video/audio clock, as well as many other functions that meet the strict demands of broadcasting and post production, the **CG-2000** is at the top of its class. It is equipped with an external input connector that supports a 10MHz signal. This allows it to be connected to a rubidium clock or GPS clock for even higher precision.



Tascam US-2x2 USB Audio/MIDI Interface

Code 238-510 £99.17

TASCAM's **US-2x2** is a powerful 2-in/2-out USB 2 Audio interface. Two of TASCAM's Ultra-HDDA mic/line preamps provide up to 57dB of gain with nearly inaudible noise and distortion specs.



Stageline MMX602 Microphone Line Mixer

Code 258-420 £149.17

6 stereo line inputs and 6 balanced mono microphone inputs. Adjustable automatic talkover (-12 dB), switchable for channel 1 or channels 1+2. Balance control for each stereo input channel. 3-way equaliser. 12 V phantom power can be switched on additionally. Master output and record output. Output can be switched stereo/mono. 482 mm (19") rack installation.



Tascam HS-20 Solid-State Recorder/Player

Code 238-640 £999.17

The **TASCAM HS-20** is a professional two-channel solid-state audio recorder and player, built for the needs of network-connected installations. Reliable recording and playback can be controlled, accessed, and scheduled from an internet connection, allowing remote access without visiting the site. The HS-20 records to either SD Card or Compact Flash media, at up to 192kHz/24-bit Broadcast WAV formats. Balanced and unbalanced connections are available on the rear panel, as well as RS-232C Serial and Parallel connections for wired remote control. It's built on TASCAM's more reliable recording platform, designed for broadcast use.



TC Helicon Voicelive Play Vocal Processor

Code 386-610 £149.16

Whether you're at the top of the charts – or just a dreamer with a microphone, **Voicelive® Play** gives you hundreds of song and artist presets to choose from, helping you create amazing vocals. Plug in your MP3 player and sing along with your favourite tracks or create instant HIT effects for your own songs.

ST

O P

Check out this **STOP PRESS** section, where we try to squeeze in a number of products which for various reasons didn't make the main catalogue pages.

Usually they've only just been released, or will be on sale soon!

R

E

S

S



Tascam DP-32SD

32 Track Digital Portastudio

Code 238-480

£374.17

The **DP-32SD** is TASCAM's biggest Portastudio yet. It records an unmatched 32 tracks to solid-state media. Up to eight tracks can be recorded at a time through its combination XLR and 1/4" combo jacks. Compression and limiting are available during recording, as well as guitar amp simulation and multi-effects for use with the instrument-level input.



Tascam DR-44WL

Portable Recorder

Code 238-560

£199.17

TASCAM's **DR-44WL** starts with high-quality stereo condenser microphones, updated with a new XY pattern and high-performance mic components. Two locking XLR inputs feed TASCAM's latest microphone preamp design, with the lowest noise level and richest sound available in a portable recorder.



Novation Audiohub

2x4 Audio Interface

Code 389-480

£133.32

Audiohub 2x4 is a combined audio interface and USB hub for electronic music production with Focusrite sound quality. It lets you connect and power all your USB gear at once, while getting ultra-low latency audio and super loud output. 2 TRS Balanced jack outputs and 4 Unbalanced RCA outputs.



Akai APC40 MkII

Ableton Live Controller

Code 265-790

£241.66

The new **APC40 MkII** incorporates five years of user feedback into its design. In addition to its sleek look, veteran APC40 users will immediately notice the enhancements that include an RGB clip-launching grid, reinforced fader design, revised knob lay out, and more.

TOP SELLERS



Rode NT1A Condenser Microphone

Code 417-005 £115.83

The **NT1A Recording Pack** now includes the popular NT1A together with a studio grade pop shield and shock mount, a 20' mic cable, dust cover and an instructional DVD.



Zoom H6 Portable Recorder

Code 377-850 £265.83

Whatever your application—live recording, professional film/video work, or broadcast ENG (electronic news gathering), etc.—the **H6** can handle it with ease.



Behringer X32 Digital Mixing Console

Code 382-820 £1499.17

The **Behringer X32** lets you focus on your event, instead of navigating a vast sea of knobs, buttons and menus like some live digital mixers.

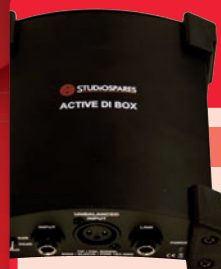

Studiospares Active DI Box

Code 448-290 £20.83

An advanced design which resolves all the problems of interfacing guitars, electronic processors and speaker signals to the input of a mixer or amplifier.



Studiospares Telescopic Stand Monitor Stand

Code 448-870 £14.20

A substantial and well engineered stand designed to support studio monitors.



Studiospares M1000 Headphones

Code 448-760

£54.16



K&M Mic Stand + Boom

Code 408-860

£34.50



Focusrite Scarlett 2i2 USB Audio Interface

Code 389-820

£90.83



Studiospares SN10 Pair Studio Monitors

Code 248-000

£82.50



Studiospares Fortissimo 15A Active PA Speaker

Code 248-260 £199.17

Highly regarded within the industry, the **Fortissimo 15A** stands direct comparison with models costing double.

All prices exclusive of VAT.

Prices and specifications are correct at press time and are subject to change without notice.

STUDIOSPARES

Your Personal Customer Number
please quote when ordering

If undelivered, please return to Studiospares, 964 North Circular Road, London NW2 7JR

